



Description

The PUMA 68FV64006X is a 2M x 32 Flash Module housed in a 68 'J' Leaded Surface mount package with access times of 90, 120 and 150ns. A 70ns variant is under development

The Output width is user configurable as 8, 16 or 32 bits wide using 4 Chip Selects (/CS1-4) for optimum application flexibility.

The module incorporates Embedded Algorithms for Program and Erase with sector architecture and supports full chip erase.

The 3.3V device also features hardware sector protection, which disables both program and erase operations in any of the 32 sectors on the module.

The device is available to commercial and industrial temperature grades.

Features

- Access times of 90, 120 and 150ns.
- 3.3V \pm 10%.
- Commercial and Industrial temperature grades
- 68 'J' Leaded JEDEC surface mount package.
- Industry standard pinout.
- User configurable as 8/16/32 bits wide
- 64K Byte sector size.
- Completely Static Operation.
- 100,000 Write and Erase (W/E) Cycles.
- 10 Year Data Retention.

Package Details

Plastic 'J' Leaded JEDEC PLCC
Max. Dimensions (mm) - 25.27 x 25.27 x 5.08

Block Diagram

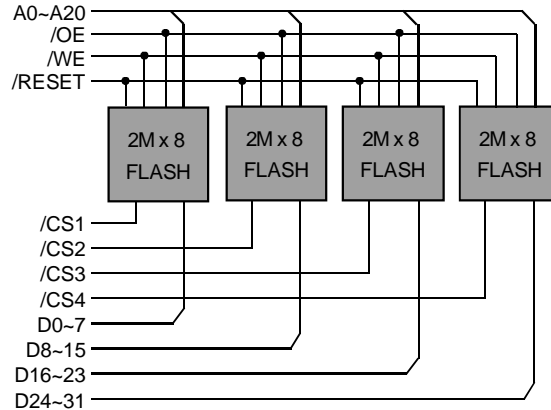

Pin Definition

See page 2.

Pin Functions

Description	Signal
Address Input	A0~A20
Data Input/Output	D0~D31
Chip Select	/CS1~4
Write Enable	/WE
Output Enable	/OE
Hardware Reset	/RESET
No Connect	NC
Power	V _{CC}
Ground	V _{SS}

Pin Definition - PUMA68F64006X

Pin	Signal	Pin	Signal
1	V _{CC}	35	V _{CC}
2	A19	36	A13
3	/CS1	37	A12
4	/CS2	38	A11
5	/CS3	39	A10
6	/CS4	40	A9
7	A17	41	A8
8	A18	42	A7
9	D16	43	D0
10	D17	44	D1
11	D18	45	D2
12	D19	46	D3
13	V _{SS}	47	V _{SS}
14	D20	48	D4
15	D21	49	D5
16	D22	50	D6
17	D23	51	D7
18	V _{CC}	52	V _{CC}
19	D24	53	D8
20	D25	54	D9
21	D26	55	D10
22	D27	56	D11
23	V _{SS}	57	V _{SS}
24	D28	58	D12
25	D29	59	D13
26	D30	60	D14
27	D31	61	D15
28	A6	62	A14
29	A5	63	A15
30	A4	64	A16
31	A3	65	/WE
32	A2	66	/OE
33	A1	67	/RESET
34	A0	68	A20

Ordering Information

PUMA 68FV64006X I - 90

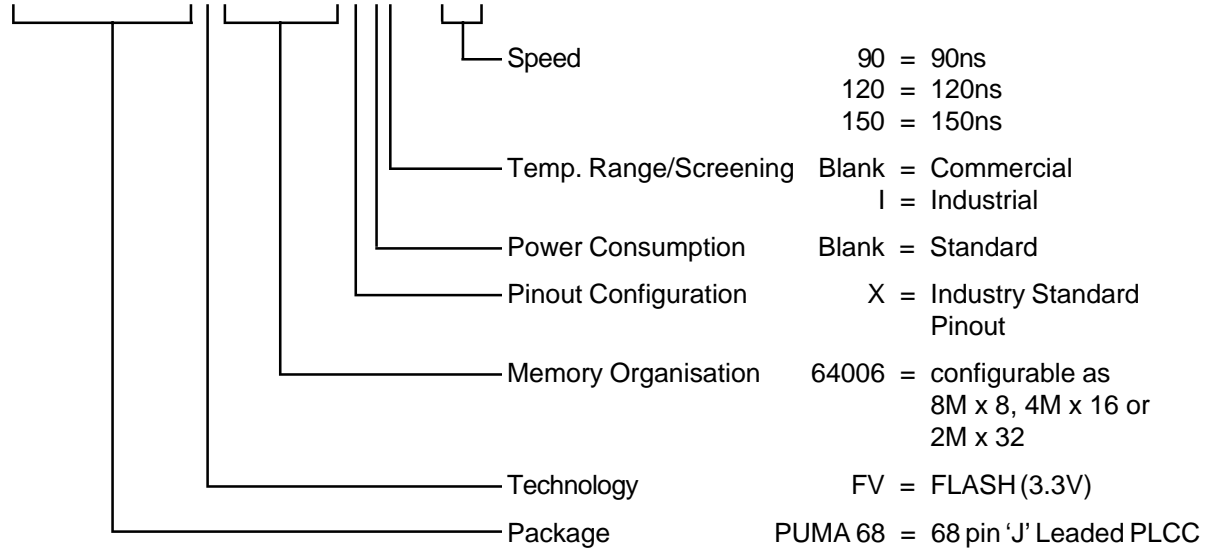

Note :

Although this data is believed to be accurate the information contained herein is not intended to and does not create any warranty of merchantability or fitness for a particular purpose.

Our products are subject to a constant process of development. Data may be changed without notice.

Products are not authorised for use as critical components in life support devices without the express written approval of a company director.

Visual Inspection Standard

All devices inspected to ANSI 2 standard

Moisture Sensitivity

Devices are **moisture sensitive**.

Shelf Life in Sealed Bag 12 months at <40°C and <90% relative humidity (RH).

After this bag has been opened, devices that will be subjected to infrared reflow, vapour phase reflow, or equivalent processing (peak package body temp 220°C) **must be** :

A : Mounted within 72 Hours at factory conditions of <30°C/60% RH

OR

B : Stored at <20% RH

If these conditions are not met or indicator card is >20% when read at 23°C +/-5% devices **require baking** as specified below.

If baking is required, devices may be baked for :-

A : 24 hours at 125°C +/-5% for high temperature device containers

OR

B : 192 hours at 40°C +5°C/-0°C and <5% RH for low temperature device containers.

Packaging Standard

Devices packaged in dry nitrogen, JED-STD-020.

Packaged in trays as standard.

Tape and reel available for shipment quantities exceeding 200pcs upon request.

Soldering Recommendations

IR/Convection -	Ramp Rate	6°C/sec max.
	Temp. exceeding 183°C	150 secs. max.
	Peak Temperature	225°C
	Time within 5°C of peak	20 secs max.
	Ramp down	6°C/sec max.
Vapour Phase -	Ramp up rate	6°C/sec max.
	Peak Temperature	215 - 219°C
	Time within 5°C of peak	60 secs max.
	Ramp down	6°C/sec max.

Note : The above recommendations are based on standard industry practice. Failure to comply with the above recommendations invalidates product warranty.