

## Features

- High Performance, Low Power AVR<sup>®</sup> 8-Bit Microcontroller
- Advanced RISC Architecture
  - 130 Powerful Instructions – Most Single Clock Cycle Execution
  - 32 x 8 General Purpose Working Registers
  - Fully Static Operation
  - Up to 16 MIPS Throughput at 16 MHz
  - On-Chip 2-cycle Multiplier
- High Endurance Non-volatile Memory Segments
  - In-System Self-programmable Flash Program Memory
    - 32K Bytes (ATmega329/ATmega3290)
    - 64K Bytes (ATmega649/ATmega6490)
  - EEPROM
    - 1K bytes (ATmega329/ATmega3290)
    - 2K bytes (ATmega649/ATmega6490)
  - Internal SRAM
    - 2K bytes (ATmega329/ATmega3290)
    - 4K bytes (ATmega649/ATmega6490)
  - Write/Erase Cycles: 10,000 Flash/ 100,000 EEPROM
  - Data retention: 20 years at 85°C/100 years at 25°C<sup>(1)</sup>
  - Optional Boot Code Section with Independent Lock Bits
    - In-System Programming by On-chip Boot Program
    - True Read-While-Write Operation
  - Programming Lock for Software Security
- JTAG (IEEE std. 1149.1 compliant) Interface
  - Boundary-scan Capabilities According to the JTAG Standard
  - Extensive On-chip Debug Support
  - Programming of Flash, EEPROM, Fuses, and Lock Bits through the JTAG Interface
- Peripheral Features
  - 4 x 25 Segment LCD Driver (ATmega329/ATmega649)
  - 4 x 40 Segment LCD Driver (ATmega3290/ATmega6490)
  - Two 8-bit Timer/Counters with Separate Prescaler and Compare Mode
  - One 16-bit Timer/Counter with Separate Prescaler, Compare Mode, and Capture Mode
  - Real Time Counter with Separate Oscillator
  - Four PWM Channels
  - 8-channel, 10-bit ADC
  - Programmable Serial USART
  - Master/Slave SPI Serial Interface
  - Universal Serial Interface with Start Condition Detector
  - Programmable Watchdog Timer with Separate On-chip Oscillator
  - On-chip Analog Comparator
  - Interrupt and Wake-up on Pin Change
- Special Microcontroller Features
  - Power-on Reset and Programmable Brown-out Detection
  - Internal Calibrated Oscillator
  - External and Internal Interrupt Sources
  - Five Sleep Modes: Idle, ADC Noise Reduction, Power-save, Power-down, and Standby
- I/O and Packages
  - 53/68 Programmable I/O Lines
  - 64-lead TQFP, 64-pad QFN/MLF, and 100-lead TQFP
- Speed Grade:
  - ATmega329V/ATmega3290V/ATmega649V/ATmega6490V:
    - 0 - 4 MHz @ 1.8 - 5.5V, 0 - 8 MHz @ 2.7 - 5.5V
  - ATmega329/3290/649/6490:
    - 0 - 8 MHz @ 2.7 - 5.5V, 0 - 16 MHz @ 4.5 - 5.5V
- Temperature range:
  - -40°C to 85°C Industrial
- Ultra-Low Power Consumption
  - Active Mode:
    - 1 MHz, 1.8V: 350 µA
    - 32 kHz, 1.8V: 20 µA (including Oscillator)
    - 32 kHz, 1.8V: 40 µA (including Oscillator and LCD)
  - Power-down Mode:
    - 100 nA at 1.8V



8-bit **AVR<sup>®</sup>**  
Microcontroller  
with In-System  
Programmable  
Flash

ATmega329/V  
ATmega3290/V  
ATmega649/V  
ATmega6490/V

Preliminary  
Summary



# 1. Pin Configurations

Figure 1-1. Pinout ATmega3290/6490

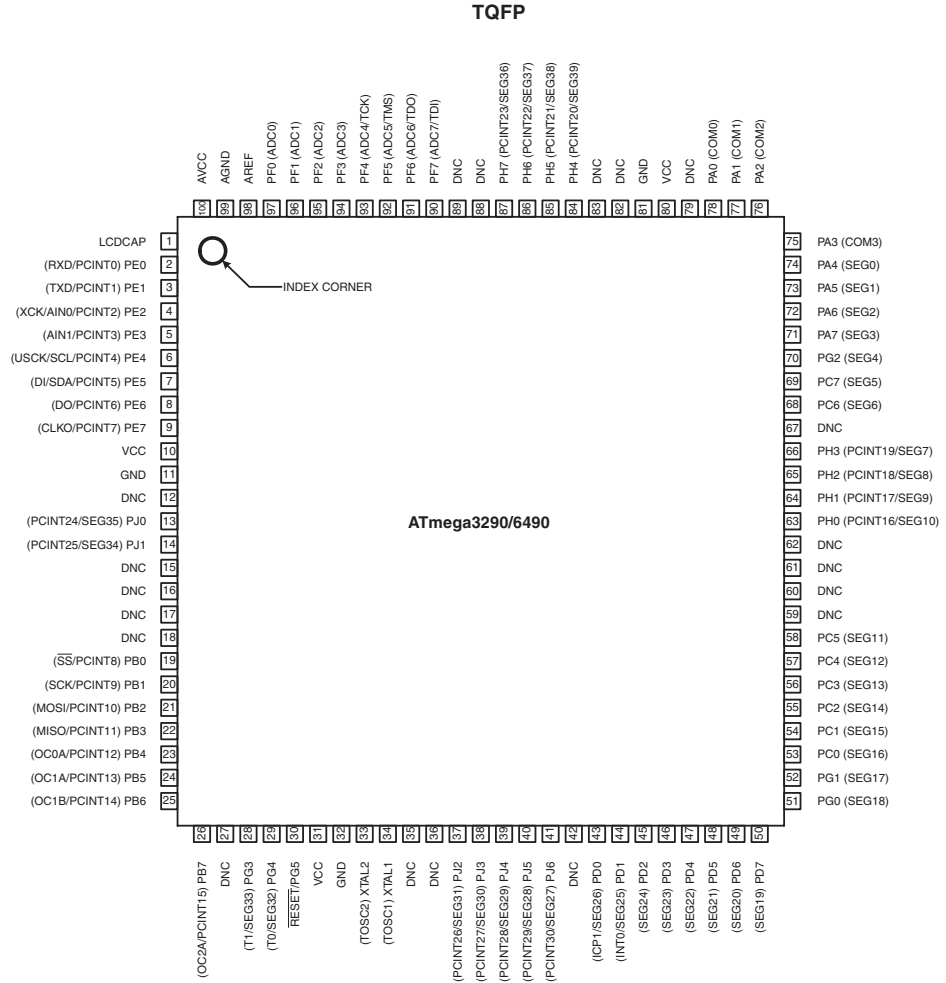

**Figure 1-2.** Pinout ATmega329/649

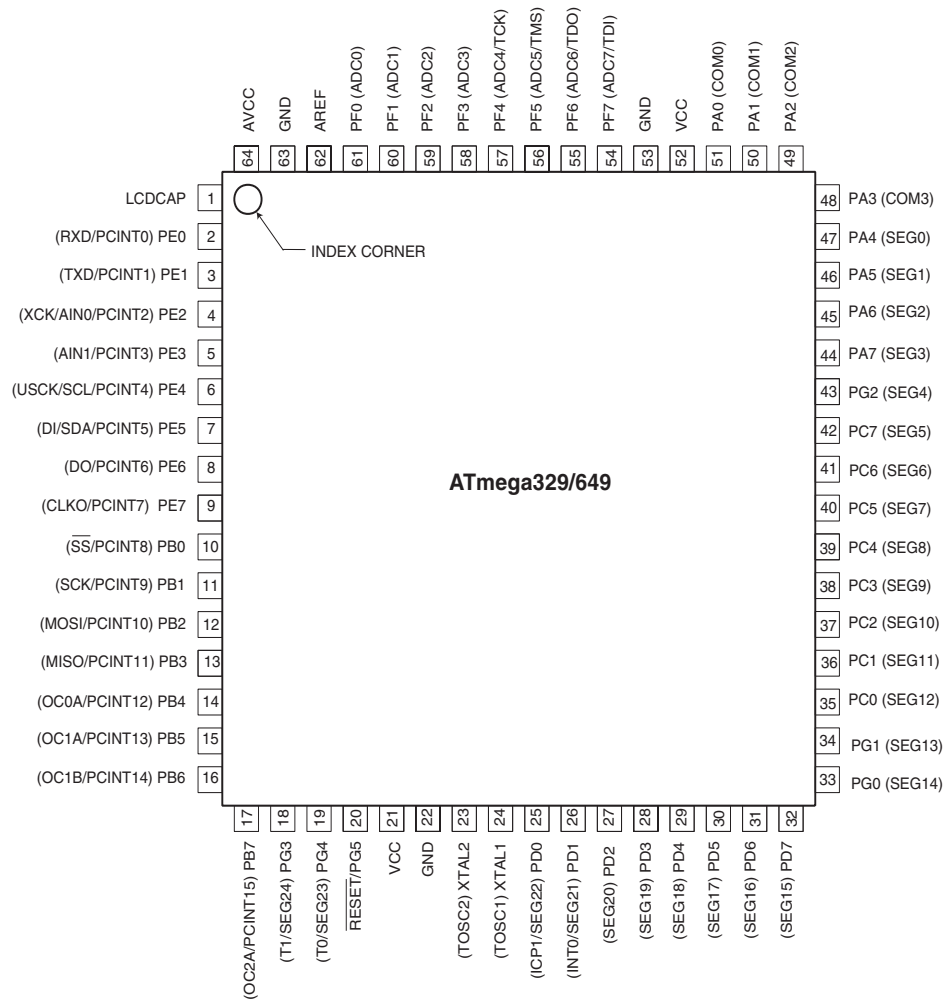

Note: The large center pad underneath the QFN/MLF packages is made of metal and internally connected to GND. It should be soldered or glued to the board to ensure good mechanical stability. If the center pad is left unconnected, the package might loosen from the board.

## 2. Disclaimer

Typical values contained in this datasheet are based on simulations and characterization of other AVR microcontrollers manufactured on the same process technology. Min and Max values will be available after the device is characterized.

## 3. Overview

The ATmega329/3290/649/6490 is a low-power CMOS 8-bit microcontroller based on the AVR enhanced RISC architecture. By executing powerful instructions in a single clock cycle, the ATmega329/3290/649/6490 achieves throughputs approaching 1 MIPS per MHz allowing the system designer to optimize power consumption versus processing speed.

### 3.1 Block Diagram

Figure 3-1. Block Diagram

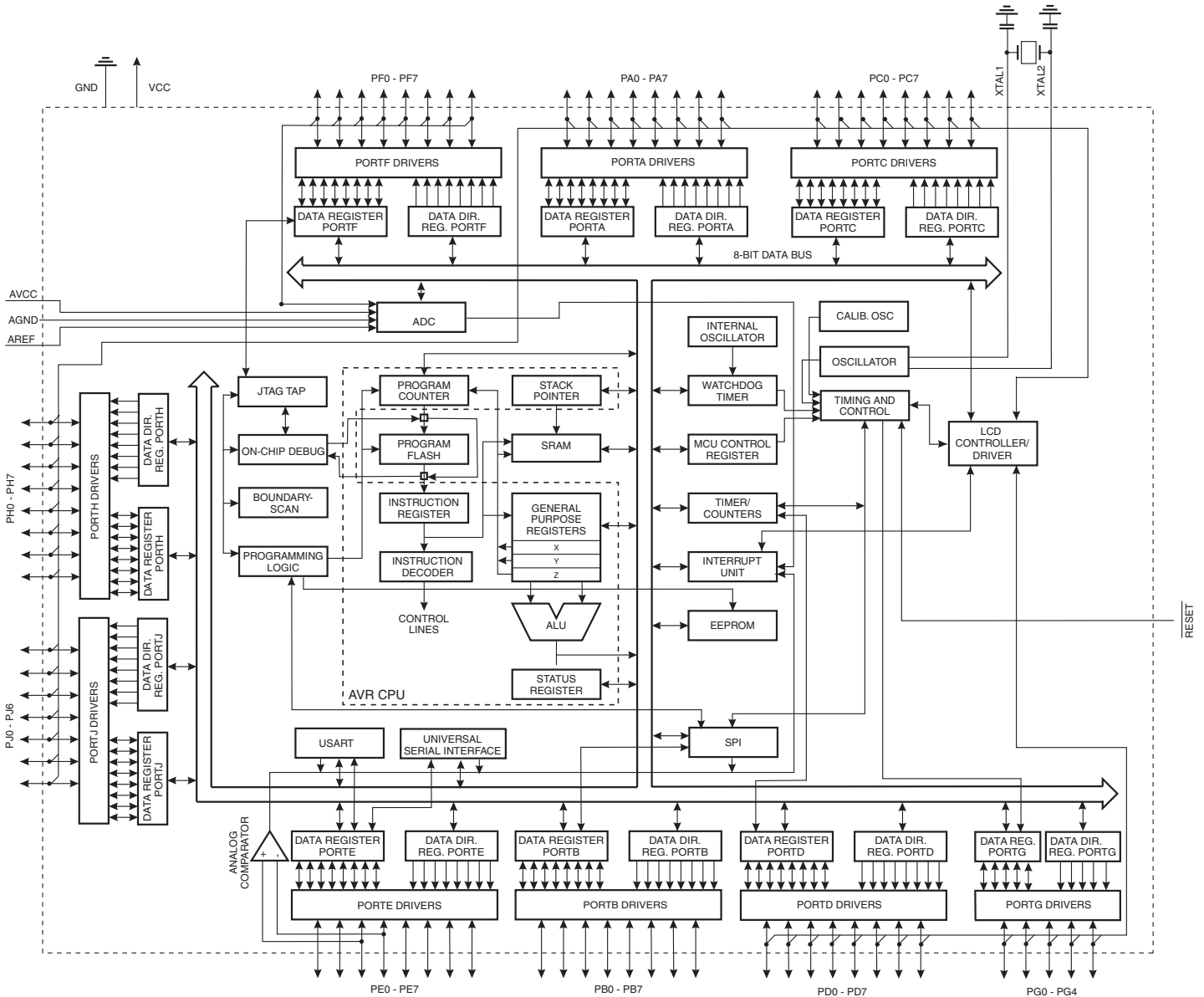

The AVR core combines a rich instruction set with 32 general purpose working registers. All the 32 registers are directly connected to the Arithmetic Logic Unit (ALU), allowing two independent registers to be accessed in one single instruction executed in one clock cycle. The resulting architecture is more code efficient while achieving throughputs up to ten times faster than conventional CISC microcontrollers.

The ATmega329/3290/649/6490 provides the following features: 32/64K bytes of In-System Programmable Flash with Read-While-Write capabilities, 1/2K bytes EEPROM, 2/4K byte SRAM, 54/69 general purpose I/O lines, 32 general purpose working registers, a JTAG interface for Boundary-scan, On-chip Debugging support and programming, a complete On-chip LCD controller with internal contrast control, three flexible Timer/Counters with compare modes, internal and external interrupts, a serial programmable USART, Universal Serial Interface with Start Condition Detector, an 8-channel, 10-bit ADC, a programmable Watchdog Timer with internal Oscillator, an SPI serial port, and five software selectable power saving modes. The Idle mode stops the CPU while allowing the SRAM, Timer/Counters, SPI port, and interrupt system to continue functioning. The Power-down mode saves the register contents but freezes the Oscillator, disabling all other chip functions until the next interrupt or hardware reset. In Power-save mode, the asynchronous timer and the LCD controller continues to run, allowing the user to maintain a timer base and operate the LCD display while the rest of the device is sleeping. The ADC Noise Reduction mode stops the CPU and all I/O modules except asynchronous timer, LCD controller and ADC, to minimize switching noise during ADC conversions. In Standby mode, the crystal/resonator Oscillator is running while the rest of the device is sleeping. This allows very fast start-up combined with low-power consumption.

The device is manufactured using Atmel's high density non-volatile memory technology. The On-chip In-System re-Programmable (ISP) Flash allows the program memory to be reprogrammed In-System through an SPI serial interface, by a conventional non-volatile memory programmer, or by an On-chip Boot program running on the AVR core. The Boot program can use any interface to download the application program in the Application Flash memory. Software in the Boot Flash section will continue to run while the Application Flash section is updated, providing true Read-While-Write operation. By combining an 8-bit RISC CPU with In-System Self-Programmable Flash on a monolithic chip, the Atmel ATmega329/3290/649/6490 is a powerful microcontroller that provides a highly flexible and cost effective solution to many embedded control applications.

The ATmega329/3290/649/6490 AVR is supported with a full suite of program and system development tools including: C Compilers, Macro Assemblers, Program Debugger/Simulators, In-Circuit Emulators, and Evaluation kits.

### 3.2 Comparison between ATmega329, ATmega3290, ATmega649 and ATmega6490

The ATmega329, ATmega3290, ATmega649, and ATmega6490 differs only in memory sizes, pin count and pinout. [Table 3-1 on page 6](#) summarizes the different configurations for the four devices.

**Table 3-1.** Configuration Summary

| Device     | Flash     | EEPROM   | RAM      | LCD Segments | General Purpose I/O Pins |
|------------|-----------|----------|----------|--------------|--------------------------|
| ATmega329  | 32K bytes | 1K bytes | 2K bytes | 4 x 25       | 54                       |
| ATmega3290 | 32K bytes | 1K bytes | 2K bytes | 4 x 40       | 69                       |
| ATmega649  | 64K bytes | 2K bytes | 4K bytes | 4 x 25       | 54                       |
| ATmega6490 | 64K bytes | 2K bytes | 4K bytes | 4 x 40       | 69                       |

### 3.3 Pin Descriptions

The following section describes the I/O-pin special functions.

#### 3.3.1 $V_{CC}$

Digital supply voltage.

#### 3.3.2 GND

Ground.

#### 3.3.3 Port A (PA7..PA0)

Port A is an 8-bit bi-directional I/O port with internal pull-up resistors (selected for each bit). The Port A output buffers have symmetrical drive characteristics with both high sink and source capability. As inputs, Port A pins that are externally pulled low will source current if the pull-up resistors are activated. The Port A pins are tri-stated when a reset condition becomes active, even if the clock is not running.

Port A also serves the functions of various special features of the ATmega329/3290/649/6490 as listed on [page 67](#).

#### 3.3.4 Port B (PB7..PB0)

Port B is an 8-bit bi-directional I/O port with internal pull-up resistors (selected for each bit). The Port B output buffers have symmetrical drive characteristics with both high sink and source capability. As inputs, Port B pins that are externally pulled low will source current if the pull-up resistors are activated. The Port B pins are tri-stated when a reset condition becomes active, even if the clock is not running.

Port B has better driving capabilities than the other ports.

Port B also serves the functions of various special features of the ATmega329/3290/649/6490 as listed on [page 68](#).

### 3.3.5 Port C (PC7..PC0)

Port C is an 8-bit bi-directional I/O port with internal pull-up resistors (selected for each bit). The Port C output buffers have symmetrical drive characteristics with both high sink and source capability. As inputs, Port C pins that are externally pulled low will source current if the pull-up resistors are activated. The Port C pins are tri-stated when a reset condition becomes active, even if the clock is not running.

Port C also serves the functions of special features of the ATmega329/3290/649/6490 as listed on [page 71](#).

### 3.3.6 Port D (PD7..PD0)

Port D is an 8-bit bi-directional I/O port with internal pull-up resistors (selected for each bit). The Port D output buffers have symmetrical drive characteristics with both high sink and source capability. As inputs, Port D pins that are externally pulled low will source current if the pull-up resistors are activated. The Port D pins are tri-stated when a reset condition becomes active, even if the clock is not running.

Port D also serves the functions of various special features of the ATmega329/3290/649/6490 as listed on [page 73](#).

### 3.3.7 Port E (PE7..PE0)

Port E is an 8-bit bi-directional I/O port with internal pull-up resistors (selected for each bit). The Port E output buffers have symmetrical drive characteristics with both high sink and source capability. As inputs, Port E pins that are externally pulled low will source current if the pull-up resistors are activated. The Port E pins are tri-stated when a reset condition becomes active, even if the clock is not running.

Port E also serves the functions of various special features of the ATmega329/3290/649/6490 as listed on [page 75](#).

### 3.3.8 Port F (PF7..PF0)

Port F serves as the analog inputs to the A/D Converter.

Port F also serves as an 8-bit bi-directional I/O port, if the A/D Converter is not used. Port pins can provide internal pull-up resistors (selected for each bit). The Port F output buffers have symmetrical drive characteristics with both high sink and source capability. As inputs, Port F pins that are externally pulled low will source current if the pull-up resistors are activated. The Port F pins are tri-stated when a reset condition becomes active, even if the clock is not running. If the JTAG interface is enabled, the pull-up resistors on pins PF7(TDI), PF5(TMS), and PF4(TCK) will be activated even if a reset occurs.

Port F also serves the functions of the JTAG interface.

### 3.3.9 Port G (PG5..PG0)

Port G is a 6-bit bi-directional I/O port with internal pull-up resistors (selected for each bit). The Port G output buffers have symmetrical drive characteristics with both high sink and source capability. As inputs, Port G pins that are externally pulled low will source current if the pull-up resistors are activated. The Port G pins are tri-stated when a reset condition becomes active, even if the clock is not running.

Port G also serves the functions of various special features of the ATmega329/3290/649/6490 as listed on [page 75](#).

### 3.3.10 Port H (PH7..PH0)

Port H is a 8-bit bi-directional I/O port with internal pull-up resistors (selected for each bit). The Port H output buffers have symmetrical drive characteristics with both high sink and source capability. As inputs, Port H pins that are externally pulled low will source current if the pull-up resistors are activated. The Port H pins are tri-stated when a reset condition becomes active, even if the clock is not running.

Port H also serves the functions of various special features of the ATmega3290/6490 as listed on [page 75](#).

### 3.3.11 Port J (PJ6..PJ0)

Port J is a 7-bit bi-directional I/O port with internal pull-up resistors (selected for each bit). The Port J output buffers have symmetrical drive characteristics with both high sink and source capability. As inputs, Port J pins that are externally pulled low will source current if the pull-up resistors are activated. The Port J pins are tri-stated when a reset condition becomes active, even if the clock is not running.

Port J also serves the functions of various special features of the ATmega3290/6490 as listed on [page 75](#).

### 3.3.12 $\overline{\text{RESET}}$

Reset input. A low level on this pin for longer than the minimum pulse length will generate a reset, even if the clock is not running. The minimum pulse length is given in “[System and Reset Characteristics](#)” on [page 330](#). Shorter pulses are not guaranteed to generate a reset.

### 3.3.13 XTAL1

Input to the inverting Oscillator amplifier and input to the internal clock operating circuit.

### 3.3.14 XTAL2

Output from the inverting Oscillator amplifier.

### 3.3.15 AVCC

AVCC is the supply voltage pin for Port F and the A/D Converter. It should be externally connected to  $V_{CC}$ , even if the ADC is not used. If the ADC is used, it should be connected to  $V_{CC}$  through a low-pass filter.

### 3.3.16 AREF

This is the analog reference pin for the A/D Converter.



### 3.3.17 LCDCAP

An external capacitor (typical > 470 nF) must be connected to the LCDCAP pin as shown in [Figure 24-2](#). This capacitor acts as a reservoir for LCD power ( $V_{LCD}$ ). A large capacitance reduces ripple on  $V_{LCD}$  but increases the time until  $V_{LCD}$  reaches its target value.

## 4. Resources

A comprehensive set of development tools, application notes and datasheets are available for download on <http://www.atmel.com/avr>.

## 5. Data Retention

Reliability Qualification results show that the projected data retention failure rate is much less than 1 PPM over 20 years at 85°C or 100 years at 25°C.



## 6. Register Summary

Note: Registers with bold type only available in ATmega3290/6490.

| Address | Name           | Bit 7                          | Bit 6         | Bit 5         | Bit 4         | Bit 3         | Bit 2         | Bit 1         | Bit 0         | Page |
|---------|----------------|--------------------------------|---------------|---------------|---------------|---------------|---------------|---------------|---------------|------|
| (0xFF)  | <b>LCDDR19</b> | <b>SEG339</b>                  | <b>SEG338</b> | <b>SEG337</b> | <b>SEG336</b> | <b>SEG335</b> | <b>SEG334</b> | <b>SEG333</b> | <b>SEG332</b> | 244  |
| (0xFE)  | LCDDR18        | <b>SEG331</b>                  | <b>SEG330</b> | <b>SEG329</b> | <b>SEG328</b> | <b>SEG327</b> | <b>SEG326</b> | <b>SEG325</b> | SEG324        | 244  |
| (0xFD)  | LCDDR17        | SEG323                         | SEG322        | SEG321        | SEG320        | SEG319        | SEG318        | SEG317        | SEG316        | 244  |
| (0xFC)  | LCDDR16        | SEG315                         | SEG314        | SEG313        | SEG312        | SEG311        | SEG310        | SEG309        | SEG308        | 244  |
| (0xFB)  | LCDDR15        | SEG307                         | SEG306        | SEG305        | SEG304        | SEG303        | SEG302        | SEG301        | SEG300        | 244  |
| (0xFA)  | <b>LCDDR14</b> | <b>SEG239</b>                  | <b>SEG238</b> | <b>SEG237</b> | <b>SEG236</b> | <b>SEG235</b> | <b>SEG234</b> | <b>SEG233</b> | <b>SEG232</b> | 244  |
| (0xF9)  | LCDDR13        | <b>SEG231</b>                  | <b>SEG230</b> | <b>SEG229</b> | <b>SEG228</b> | <b>SEG227</b> | <b>SEG226</b> | <b>SEG225</b> | SEG224        | 244  |
| (0xF8)  | LCDDR12        | SEG223                         | SEG222        | SEG221        | SEG220        | SEG219        | SEG218        | SEG217        | SEG216        | 244  |
| (0xF7)  | LCDDR11        | SEG215                         | SEG214        | SEG213        | SEG212        | SEG211        | SEG210        | SEG209        | SEG208        | 244  |
| (0xF6)  | LCDDR10        | SEG207                         | SEG206        | SEG205        | SEG204        | SEG203        | SEG202        | SEG201        | SEG200        | 244  |
| (0xF5)  | <b>LCDDR09</b> | <b>SEG139</b>                  | <b>SEG138</b> | <b>SEG137</b> | <b>SEG136</b> | <b>SEG135</b> | <b>SEG134</b> | <b>SEG133</b> | <b>SEG132</b> | 244  |
| (0xF4)  | LCDDR08        | <b>SEG131</b>                  | <b>SEG130</b> | <b>SEG129</b> | <b>SEG128</b> | <b>SEG127</b> | <b>SEG126</b> | <b>SEG125</b> | SEG124        | 244  |
| (0xF3)  | LCDDR07        | SEG123                         | SEG122        | SEG121        | SEG120        | SEG119        | SEG118        | SEG117        | SEG116        | 244  |
| (0xF2)  | LCDDR06        | SEG115                         | SEG114        | SEG113        | SEG112        | SEG111        | SEG110        | SEG109        | SEG108        | 244  |
| (0xF1)  | LCDDR05        | SEG107                         | SEG106        | SEG105        | SEG104        | SEG103        | SEG102        | SEG101        | SEG100        | 244  |
| (0xF0)  | <b>LCDDR04</b> | <b>SEG039</b>                  | <b>SEG038</b> | <b>SEG037</b> | <b>SEG036</b> | <b>SEG035</b> | <b>SEG034</b> | <b>SEG033</b> | <b>SEG032</b> | 244  |
| (0xEF)  | LCDDR03        | <b>SEG031</b>                  | <b>SEG030</b> | <b>SEG029</b> | <b>SEG028</b> | <b>SEG027</b> | <b>SEG026</b> | <b>SEG025</b> | SEG024        | 244  |
| (0xEE)  | LCDDR02        | SEG023                         | SEG022        | SEG021        | SEG020        | SEG019        | SEG018        | SEG017        | SEG016        | 244  |
| (0xED)  | LCDDR01        | SEG015                         | SEG014        | SEG013        | SEG012        | SEG011        | SEG010        | SEG009        | SEG008        | 244  |
| (0xEC)  | LCDDR00        | SEG007                         | SEG006        | SEG005        | SEG004        | SEG003        | SEG002        | SEG001        | SEG000        | 244  |
| (0xEB)  | Reserved       | -                              | -             | -             | -             | -             | -             | -             | -             | -    |
| (0xEA)  | Reserved       | -                              | -             | -             | -             | -             | -             | -             | -             | -    |
| (0xE9)  | Reserved       | -                              | -             | -             | -             | -             | -             | -             | -             | -    |
| (0xE8)  | Reserved       | -                              | -             | -             | -             | -             | -             | -             | -             | -    |
| (0xE7)  | LCDDC2         | LCDDC2                         | LCDDC1        | LCDDC0        | -             | LCDDC3        | LCDDC2        | LCDDC1        | LCDDC0        | 243  |
| (0xE6)  | LCDFRR         | -                              | LCDFPS1       | LCDFPS0       | LCDFPS0       | -             | LCDFCD2       | LCDFCD1       | LCDFCD0       | 241  |
| (0xE5)  | LCDCRB         | LCDCS                          | LCDCB         | LCDCM1        | LCDCM0        | <b>LCDCM3</b> | LCDCM2        | LCDCM1        | LCDCM0        | 239  |
| (0xE4)  | LCDCRA         | LCDCEN                         | LCDCAB        | -             | LCDCIF        | LCDCIE        | -             | -             | LCDCBL        | 239  |
| (0xE3)  | Reserved       | -                              | -             | -             | -             | -             | -             | -             | -             | -    |
| (0xE2)  | Reserved       | -                              | -             | -             | -             | -             | -             | -             | -             | -    |
| (0xE1)  | Reserved       | -                              | -             | -             | -             | -             | -             | -             | -             | -    |
| (0xE0)  | Reserved       | -                              | -             | -             | -             | -             | -             | -             | -             | -    |
| (0xDF)  | Reserved       | -                              | -             | -             | -             | -             | -             | -             | -             | -    |
| (0xDE)  | Reserved       | -                              | -             | -             | -             | -             | -             | -             | -             | -    |
| (0xDD)  | <b>PORTJ</b>   | -                              | <b>PORTJ6</b> | <b>PORTJ5</b> | <b>PORTJ4</b> | <b>PORTJ3</b> | <b>PORTJ2</b> | <b>PORTJ1</b> | <b>PORTJ0</b> | 90   |
| (0xDC)  | <b>DDRJ</b>    | -                              | <b>DDJ6</b>   | <b>DDJ5</b>   | <b>DDJ4</b>   | <b>DDJ3</b>   | <b>DDJ2</b>   | <b>DDJ1</b>   | <b>DDJ0</b>   | 90   |
| (0xDB)  | <b>PINJ</b>    | -                              | <b>PINJ6</b>  | <b>PINJ5</b>  | <b>PINJ4</b>  | <b>PINJ3</b>  | <b>PINJ2</b>  | <b>PINJ1</b>  | <b>PINJ0</b>  | 90   |
| (0xDA)  | <b>PORTH</b>   | <b>PORTH7</b>                  | <b>PORTH6</b> | <b>PORTH5</b> | <b>PORTH4</b> | <b>PORTH3</b> | <b>PORTH2</b> | <b>PORTH1</b> | <b>PORTH0</b> | 89   |
| (0xD9)  | <b>DDRH</b>    | <b>DDH7</b>                    | <b>DDH6</b>   | <b>DDH5</b>   | <b>DDH4</b>   | <b>DDH3</b>   | <b>DDH2</b>   | <b>DDH1</b>   | <b>DDH0</b>   | 90   |
| (0xD8)  | <b>PINH</b>    | <b>PINH7</b>                   | <b>PINH6</b>  | <b>PINH5</b>  | <b>PINH4</b>  | <b>PINH3</b>  | <b>PINH2</b>  | <b>PINH1</b>  | <b>PINH0</b>  | 90   |
| (0xD7)  | Reserved       | -                              | -             | -             | -             | -             | -             | -             | -             | -    |
| (0xD6)  | Reserved       | -                              | -             | -             | -             | -             | -             | -             | -             | -    |
| (0xD5)  | Reserved       | -                              | -             | -             | -             | -             | -             | -             | -             | -    |
| (0xD4)  | Reserved       | -                              | -             | -             | -             | -             | -             | -             | -             | -    |
| (0xD3)  | Reserved       | -                              | -             | -             | -             | -             | -             | -             | -             | -    |
| (0xD2)  | Reserved       | -                              | -             | -             | -             | -             | -             | -             | -             | -    |
| (0xD1)  | Reserved       | -                              | -             | -             | -             | -             | -             | -             | -             | -    |
| (0xD0)  | Reserved       | -                              | -             | -             | -             | -             | -             | -             | -             | -    |
| (0xCF)  | Reserved       | -                              | -             | -             | -             | -             | -             | -             | -             | -    |
| (0xCE)  | Reserved       | -                              | -             | -             | -             | -             | -             | -             | -             | -    |
| (0xCD)  | Reserved       | -                              | -             | -             | -             | -             | -             | -             | -             | -    |
| (0xCC)  | Reserved       | -                              | -             | -             | -             | -             | -             | -             | -             | -    |
| (0xCB)  | Reserved       | -                              | -             | -             | -             | -             | -             | -             | -             | -    |
| (0xCA)  | Reserved       | -                              | -             | -             | -             | -             | -             | -             | -             | -    |
| (0xC9)  | Reserved       | -                              | -             | -             | -             | -             | -             | -             | -             | -    |
| (0xC8)  | Reserved       | -                              | -             | -             | -             | -             | -             | -             | -             | -    |
| (0xC7)  | Reserved       | -                              | -             | -             | -             | -             | -             | -             | -             | -    |
| (0xC6)  | UDR0           | USART0 Data Register           |               |               |               |               |               |               |               | 190  |
| (0xC5)  | UBRR0H         | USART0 Baud Rate Register High |               |               |               |               |               | 194           |               |      |
| (0xC4)  | UBRR0L         | USART0 Baud Rate Register Low  |               |               |               |               |               |               |               | 194  |

| Address | Name     | Bit 7   | Bit 6  | Bit 5  | Bit 4  | Bit 3   | Bit 2   | Bit 1   | Bit 0   | Page |
|---------|----------|---|--------|--------|--------|---------|---------|---------|---------|------|
| (0xC3)  | Reserved | -   | -      | -      | -      | -       | -       | -       | -       |      |
| (0xC2)  | UCSR0C   | -   | UMSEL0 | UPM01  | UPM00  | USBS0   | UCSZ01  | UCSZ00  | UCPOL0  | 192  |
| (0xC1)  | UCSR0B   | RXCIE0  | TXCIE0 | UDRIE0 | RXEN0  | TXEN0   | UCSZ02  | RXB80   | TXB80   | 191  |
| (0xC0)  | UCSR0A   | RXC0  | TXC0   | UDRE0  | FE0    | DOR0    | UPE0    | U2X0    | MPCM0   | 190  |
| (0xBF)  | Reserved | -   | -      | -      | -      | -       | -       | -       | -       |      |
| (0xBE)  | Reserved | -   | -      | -      | -      | -       | -       | -       | -       |      |
| (0xBD)  | Reserved | -   | -      | -      | -      | -       | -       | -       | -       |      |
| (0xBC)  | Reserved | -   | -      | -      | -      | -       | -       | -       | -       |      |
| (0xBB)  | Reserved | -   | -      | -      | -      | -       | -       | -       | -       |      |
| (0xBA)  | USIDR    | USI Data Register                             |        |        |        |         |         |         |         | 203  |
| (0xB9)  | USISR    | USISIF  | USIOIF | USIPF  | USIDC  | USICNT3 | USICNT2 | USICNT1 | USICNT0 | 203  |
| (0xB8)  | USICR    | USISIE  | USIOIE | USIWM1 | USIWM0 | USICS1  | USICS0  | USICLK  | USITC   | 204  |
| (0xB7)  | Reserved | -   | -      | -      | -      | -       | -       | -       | -       |      |
| (0xB6)  | ASSR     | -   | -      | -      | EXCLK  | AS2     | TCN2UB  | OCR2UB  | TCR2UB  | 155  |
| (0xB5)  | Reserved | -   | -      | -      | -      | -       | -       | -       | -       |      |
| (0xB4)  | Reserved | -   | -      | -      | -      | -       | -       | -       | -       |      |
| (0xB3)  | OCR2A    | Timer/Counter 2 Output Compare Register A     |        |        |        |         |         |         |         | 155  |
| (0xB2)  | TCNT2    | Timer/Counter2                                |        |        |        |         |         |         |         | 155  |
| (0xB1)  | Reserved | -   | -      | -      | -      | -       | -       | -       | -       |      |
| (0xB0)  | TCCR2A   | FOC2A   | WGM20  | COM2A1 | COM2A0 | WGM21   | CS22    | CS21    | CS20    | 153  |
| (0xAF)  | Reserved | -   | -      | -      | -      | -       | -       | -       | -       |      |
| (0xAE)  | Reserved | -   | -      | -      | -      | -       | -       | -       | -       |      |
| (0xAD)  | Reserved | -   | -      | -      | -      | -       | -       | -       | -       |      |
| (0xAC)  | Reserved | -   | -      | -      | -      | -       | -       | -       | -       |      |
| (0xAB)  | Reserved | -   | -      | -      | -      | -       | -       | -       | -       |      |
| (0xAA)  | Reserved | -   | -      | -      | -      | -       | -       | -       | -       |      |
| (0xA9)  | Reserved | -   | -      | -      | -      | -       | -       | -       | -       |      |
| (0xA8)  | Reserved | -   | -      | -      | -      | -       | -       | -       | -       |      |
| (0xA7)  | Reserved | -   | -      | -      | -      | -       | -       | -       | -       |      |
| (0xA6)  | Reserved | -   | -      | -      | -      | -       | -       | -       | -       |      |
| (0xA5)  | Reserved | -   | -      | -      | -      | -       | -       | -       | -       |      |
| (0xA4)  | Reserved | -   | -      | -      | -      | -       | -       | -       | -       |      |
| (0xA3)  | Reserved | -   | -      | -      | -      | -       | -       | -       | -       |      |
| (0xA2)  | Reserved | -   | -      | -      | -      | -       | -       | -       | -       |      |
| (0xA1)  | Reserved | -   | -      | -      | -      | -       | -       | -       | -       |      |
| (0xA0)  | Reserved | -   | -      | -      | -      | -       | -       | -       | -       |      |
| (0x9F)  | Reserved | -   | -      | -      | -      | -       | -       | -       | -       |      |
| (0x9E)  | Reserved | -   | -      | -      | -      | -       | -       | -       | -       |      |
| (0x9D)  | Reserved | -   | -      | -      | -      | -       | -       | -       | -       |      |
| (0x9C)  | Reserved | -   | -      | -      | -      | -       | -       | -       | -       |      |
| (0x9B)  | Reserved | -   | -      | -      | -      | -       | -       | -       | -       |      |
| (0x9A)  | Reserved | -   | -      | -      | -      | -       | -       | -       | -       |      |
| (0x99)  | Reserved | -   | -      | -      | -      | -       | -       | -       | -       |      |
| (0x98)  | Reserved | -   | -      | -      | -      | -       | -       | -       | -       |      |
| (0x97)  | Reserved | -   | -      | -      | -      | -       | -       | -       | -       |      |
| (0x96)  | Reserved | -   | -      | -      | -      | -       | -       | -       | -       |      |
| (0x95)  | Reserved | -   | -      | -      | -      | -       | -       | -       | -       |      |
| (0x94)  | Reserved | -   | -      | -      | -      | -       | -       | -       | -       |      |
| (0x93)  | Reserved | -   | -      | -      | -      | -       | -       | -       | -       |      |
| (0x92)  | Reserved | -   | -      | -      | -      | -       | -       | -       | -       |      |
| (0x91)  | Reserved | -   | -      | -      | -      | -       | -       | -       | -       |      |
| (0x90)  | Reserved | -   | -      | -      | -      | -       | -       | -       | -       |      |
| (0x8F)  | Reserved | -   | -      | -      | -      | -       | -       | -       | -       |      |
| (0x8E)  | Reserved | -   | -      | -      | -      | -       | -       | -       | -       |      |
| (0x8D)  | Reserved | -   | -      | -      | -      | -       | -       | -       | -       |      |
| (0x8C)  | Reserved | -   | -      | -      | -      | -       | -       | -       | -       |      |
| (0x8B)  | OCR1BH   | Timer/Counter1 Output Compare Register B High |        |        |        |         |         |         |         | 136  |
| (0x8A)  | OCR1BL   | Timer/Counter1 Output Compare Register B Low  |        |        |        |         |         |         |         | 136  |
| (0x89)  | OCR1AH   | Timer/Counter1 Output Compare Register A High |        |        |        |         |         |         |         | 136  |
| (0x88)  | OCR1AL   | Timer/Counter1 Output Compare Register A Low  |        |        |        |         |         |         |         | 136  |
| (0x87)  | ICR1H    | Timer/Counter1 Input Capture Register High    |        |        |        |         |         |         |         | 137  |
| (0x86)  | ICR1L    | Timer/Counter1 Input Capture Register Low     |        |        |        |         |         |         |         | 137  |
| (0x85)  | TCNT1H   | Timer/Counter1 High                           |        |        |        |         |         |         |         | 136  |



| Address     | Name     | Bit 7                                     | Bit 6   | Bit 5   | Bit 4   | Bit 3   | Bit 2   | Bit 1    | Bit 0   | Page      |
|-------------|----------|---|---------|---------|---------|---------|---------|----------|---------|-----------|
| (0x84)      | TCNT1L   | Timer/Counter1 Low                        |         |         |         |         |         |          |         | 136       |
| (0x83)      | Reserved | -   | -       | -       | -       | -       | -       | -        | -       |           |
| (0x82)      | TCCR1C   | FOC1A                                     | FOC1B   | -       | -       | -       | -       | -        | -       | 135       |
| (0x81)      | TCCR1B   | ICNC1                                     | ICES1   | -       | WGM13   | WGM12   | CS12    | CS11     | CS10    | 134       |
| (0x80)      | TCCR1A   | COM1A1                                    | COM1A0  | COM1B1  | COM1B0  | -       | -       | WGM11    | WGM10   | 132       |
| (0x7F)      | DIDR1    | -   | -       | -       | -       | -       | -       | AIN1D    | AIN0D   | 210       |
| (0x7E)      | DIDR0    | ADC7D                                     | ADC6D   | ADC5D   | ADC4D   | ADC3D   | ADC2D   | ADC1D    | ADC0D   | 227       |
| (0x7D)      | Reserved | -   | -       | -       | -       | -       | -       | -        | -       |           |
| (0x7C)      | ADMUX    | REFS1                                     | REFS0   | ADLAR   | MUX4    | MUX3    | MUX2    | MUX1     | MUX0    | 223       |
| (0x7B)      | ADCSRB   | -   | ACME    | -       | -       | -       | ADTS2   | ADTS1    | ADTS0   | 209/227   |
| (0x7A)      | ADCSRA   | ADEN                                      | ADSC    | ADATE   | ADIF    | ADIE    | ADPS2   | ADPS1    | ADPS0   | 225       |
| (0x79)      | ADCH     | ADC Data Register High                    |         |         |         |         |         |          |         | 226       |
| (0x78)      | ADCL     | ADC Data Register Low                     |         |         |         |         |         |          |         | 226       |
| (0x77)      | Reserved | -   | -       | -       | -       | -       | -       | -        | -       |           |
| (0x76)      | Reserved | -   | -       | -       | -       | -       | -       | -        | -       |           |
| (0x75)      | Reserved | -   | -       | -       | -       | -       | -       | -        | -       |           |
| (0x74)      | Reserved | -   | -       | -       | -       | -       | -       | -        | -       |           |
| (0x73)      | PCMSK3   | -   | PCINT30 | PCINT29 | PCINT28 | PCINT27 | PCINT26 | PCINT25  | PCINT24 | 57        |
| (0x72)      | Reserved | -   | -       | -       | -       | -       | -       | -        | -       |           |
| (0x71)      | Reserved | -   | -       | -       | -       | -       | -       | -        | -       |           |
| (0x70)      | TIMSK2   | -   | -       | -       | -       | -       | -       | OCIE2A   | TOIE2   | 156       |
| (0x6F)      | TIMSK1   | -   | -       | ICIE1   | -       | -       | OCIE1B  | OCIE1A   | TOIE1   | 137       |
| (0x6E)      | TIMSK0   | -   | -       | -       | -       | -       | -       | OCIE0A   | TOIE0   | 106       |
| (0x6D)      | PCMSK2   | PCINT23                                   | PCINT22 | PCINT21 | PCINT20 | PCINT19 | PCINT18 | PCINT17  | PCINT16 | 57        |
| (0x6C)      | PCMSK1   | PCINT15                                   | PCINT14 | PCINT13 | PCINT12 | PCINT11 | PCINT10 | PCINT9   | PCINT8  | 58        |
| (0x6B)      | PCMSK0   | PCINT7                                    | PCINT6  | PCINT5  | PCINT4  | PCINT3  | PCINT2  | PCINT1   | PCINT0  | 58        |
| (0x6A)      | Reserved | -   | -       | -       | -       | -       | -       | -        | -       |           |
| (0x69)      | EICRA    | -   | -       | -       | -       | -       | -       | ISC01    | ISC00   | 55        |
| (0x68)      | Reserved | -   | -       | -       | -       | -       | -       | -        | -       |           |
| (0x67)      | Reserved | -   | -       | -       | -       | -       | -       | -        | -       |           |
| (0x66)      | OSCCAL   | Oscillator Calibration Register [CAL7..0] |         |         |         |         |         |          |         | 32        |
| (0x65)      | Reserved | -   | -       | -       | -       | -       | -       | -        | -       |           |
| (0x64)      | PRR      | -   | -       | -       | PRLCD   | PRTIM1  | PRSPI   | PSUSART0 | PRADC   | 40        |
| (0x63)      | Reserved | -   | -       | -       | -       | -       | -       | -        | -       |           |
| (0x62)      | Reserved | -   | -       | -       | -       | -       | -       | -        | -       |           |
| (0x61)      | CLKPR    | CLKPCE                                    | -       | -       | -       | CLKPS3  | CLKPS2  | CLKPS1   | CLKPS0  | 33        |
| (0x60)      | WDTCR    | -   | -       | -       | WDCE    | WDE     | WDP2    | WDP1     | WDP0    | 48        |
| 0x3F (0x5F) | SREG     | I   | T       | H       | S       | V       | N       | Z        | C       | 12        |
| 0x3E (0x5E) | SPH      | Stack Pointer High                        |         |         |         |         |         |          |         | 14        |
| 0x3D (0x5D) | SPL      | Stack Pointer Low                         |         |         |         |         |         |          |         | 14        |
| 0x3C (0x5C) | Reserved | -   | -       | -       | -       | -       | -       | -        | -       |           |
| 0x3B (0x5B) | Reserved | -   | -       | -       | -       | -       | -       | -        | -       |           |
| 0x3A (0x5A) | Reserved | -   | -       | -       | -       | -       | -       | -        | -       |           |
| 0x39 (0x59) | Reserved | -   | -       | -       | -       | -       | -       | -        | -       |           |
| 0x38 (0x58) | Reserved | -   | -       | -       | -       | -       | -       | -        | -       |           |
| 0x37 (0x57) | SPMCSR   | SPMIE                                     | RWWSB   | -       | RWWSRE  | BLBSET  | PGWRT   | PGERS    | SPMEN   | 291       |
| 0x36 (0x56) | Reserved | -   | -       | -       | -       | -       | -       | -        | -       |           |
| 0x35 (0x55) | MCUCR    | JTD                                       | -       | -       | PUD     | -       | -       | IVSEL    | IVCE    | 52/87/254 |
| 0x34 (0x54) | MCUSR    | -   | -       | -       | JTRF    | WDRF    | BORF    | EXTRF    | PORF    | 47        |
| 0x33 (0x53) | SMCR     | -   | -       | -       | -       | SM2     | SM1     | SM0      | SE      | 39        |
| 0x32 (0x52) | Reserved | -   | -       | -       | -       | -       | -       | -        | -       |           |
| 0x31 (0x51) | OCDR     | IDRD/OCDR7                                | OCDR6   | OCDR5   | OCDR4   | OCDR3   | OCDR2   | OCDR1    | OCDR0   | 250       |
| 0x30 (0x50) | ACSR     | ACD                                       | ACBG    | ACO     | ACI     | ACIE    | ACIC    | ACIS1    | ACIS0   | 209       |
| 0x2F (0x4F) | Reserved | -   | -       | -       | -       | -       | -       | -        | -       |           |
| 0x2E (0x4E) | SPDR     | SPI Data Register                         |         |         |         |         |         |          |         | 167       |
| 0x2D (0x4D) | SPSR     | SPIF                                      | WCOL    | -       | -       | -       | -       | -        | SPI2X   | 167       |
| 0x2C (0x4C) | SPCR     | SPIE                                      | SPE     | DORD    | MSTR    | CPOL    | CPHA    | SPR1     | SPR0    | 165       |
| 0x2B (0x4B) | GPIOR2   | General Purpose I/O Register              |         |         |         |         |         |          |         | 25        |
| 0x2A (0x4A) | GPIOR1   | General Purpose I/O Register              |         |         |         |         |         |          |         | 25        |
| 0x29 (0x49) | Reserved | -   | -       | -       | -       | -       | -       | -        | -       |           |
| 0x28 (0x48) | Reserved | -   | -       | -       | -       | -       | -       | -        | -       |           |
| 0x27 (0x47) | OCRA     | Timer/Counter0 Output Compare A           |         |         |         |         |         |          |         | 105       |
| 0x26 (0x46) | TCNT0    | Timer/Counter0                            |         |         |         |         |         |          |         | 105       |

| Address     | Name     | Bit 7                        | Bit 6  | Bit 5  | Bit 4  | Bit 3  | Bit 2                        | Bit 1  | Bit 0  | Page    |
|-------------|----------|------------------------------|--------|--------|--------|--------|------------------------------|--------|--------|---------|
| 0x25 (0x45) | Reserved | -                            | -      | -      | -      | -      | -                            | -      | -      |         |
| 0x24 (0x44) | TCCR0A   | FOC0A                        | WGM00  | COM0A1 | COM0A0 | WGM01  | CS02                         | CS01   | CS00   | 103     |
| 0x23 (0x43) | GTCCR    | TSM                          | -      | -      | -      | -      | -                            | PSR2   | PSR10  | 108/157 |
| 0x22 (0x42) | EEARH    | -                            | -      | -      | -      | -      | EEPROM Address Register High |        |        | 22      |
| 0x21 (0x41) | EEARL    | EEPROM Address Register Low  |        |        |        |        |                              |        |        | 22      |
| 0x20 (0x40) | EEDR     | EEPROM Data Register         |        |        |        |        |                              |        |        | 22      |
| 0x1F (0x3F) | EECR     | -                            | -      | -      | -      | EERIE  | EEMWE                        | EWE    | EERE   | 22      |
| 0x1E (0x3E) | GPOR0    | General Purpose I/O Register |        |        |        |        |                              |        |        | 25      |
| 0x1D (0x3D) | EIMSK    | PCIE3                        | PCIE2  | PCIE1  | PCIE0  | -      | -                            | -      | INT0   | 55      |
| 0x1C (0x3C) | EIFR     | PCIF3                        | PCIF2  | PCIF1  | PCIF0  | -      | -                            | -      | INTF0  | 56      |
| 0x1B (0x3B) | Reserved | -                            | -      | -      | -      | -      | -                            | -      | -      |         |
| 0x1A (0x3A) | Reserved | -                            | -      | -      | -      | -      | -                            | -      | -      |         |
| 0x19 (0x39) | Reserved | -                            | -      | -      | -      | -      | -                            | -      | -      |         |
| 0x18 (0x38) | Reserved | -                            | -      | -      | -      | -      | -                            | -      | -      |         |
| 0x17 (0x37) | TIFR2    | -                            | -      | -      | -      | -      | -                            | OCF2A  | TOV2   | 157     |
| 0x16 (0x36) | TIFR1    | -                            | -      | ICF1   | -      | -      | OCF1B                        | OCF1A  | TOV1   | 138     |
| 0x15 (0x35) | TIFR0    | -                            | -      | -      | -      | -      | -                            | OCF0A  | TOV0   | 106     |
| 0x14 (0x34) | PORTG    | -                            | -      | -      | PORTG4 | PORTG3 | PORTG2                       | PORTG1 | PORTG0 | 89      |
| 0x13 (0x33) | DDRG     | -                            | -      | -      | DDG4   | DDG3   | DDG2                         | DDG1   | DDG0   | 89      |
| 0x12 (0x32) | PING     | -                            | -      | PING5  | PING4  | PING3  | PING2                        | PING1  | PING0  | 89      |
| 0x11 (0x31) | PORTF    | PORTF7                       | PORTF6 | PORTF5 | PORTF4 | PORTF3 | PORTF2                       | PORTF1 | PORTF0 | 89      |
| 0x10 (0x30) | DDRF     | DDF7                         | DDF6   | DDF5   | DDF4   | DDF3   | DDF2                         | DDF1   | DDF0   | 89      |
| 0x0F (0x2F) | PINF     | PINF7                        | PINF6  | PINF5  | PINF4  | PINF3  | PINF2                        | PINF1  | PINF0  | 89      |
| 0x0E (0x2E) | PORTE    | PORTE7                       | PORTE6 | PORTE5 | PORTE4 | PORTE3 | PORTE2                       | PORTE1 | PORTE0 | 88      |
| 0x0D (0x2D) | DDRE     | DDE7                         | DDE6   | DDE5   | DDE4   | DDE3   | DDE2                         | DDE1   | DDE0   | 88      |
| 0x0C (0x2C) | PINE     | PINE7                        | PINE6  | PINE5  | PINE4  | PINE3  | PINE2                        | PINE1  | PINE0  | 89      |
| 0x0B (0x2B) | PORTD    | PORTD7                       | PORTD6 | PORTD5 | PORTD4 | PORTD3 | PORTD2                       | PORTD1 | PORTD0 | 88      |
| 0x0A (0x2A) | DDRD     | DDD7                         | DDD6   | DDD5   | DDD4   | DDD3   | DDD2                         | DDD1   | DDD0   | 88      |
| 0x09 (0x29) | PIND     | PIND7                        | PIND6  | PIND5  | PIND4  | PIND3  | PIND2                        | PIND1  | PIND0  | 88      |
| 0x08 (0x28) | PORTC    | PORTC7                       | PORTC6 | PORTC5 | PORTC4 | PORTC3 | PORTC2                       | PORTC1 | PORTC0 | 88      |
| 0x07 (0x27) | DDRC     | DDC7                         | DDC6   | DDC5   | DDC4   | DDC3   | DDC2                         | DDC1   | DDC0   | 88      |
| 0x06 (0x26) | PINC     | PINC7                        | PINC6  | PINC5  | PINC4  | PINC3  | PINC2                        | PINC1  | PINC0  | 88      |
| 0x05 (0x25) | PORTB    | PORTB7                       | PORTB6 | PORTB5 | PORTB4 | PORTB3 | PORTB2                       | PORTB1 | PORTB0 | 87      |
| 0x04 (0x24) | DDRB     | DDB7                         | DDB6   | DDB5   | DDB4   | DDB3   | DDB2                         | DDB1   | DDB0   | 87      |
| 0x03 (0x23) | PINB     | PINB7                        | PINB6  | PINB5  | PINB4  | PINB3  | PINB2                        | PINB1  | PINB0  | 87      |
| 0x02 (0x22) | PORTA    | PORTA7                       | PORTA6 | PORTA5 | PORTA4 | PORTA3 | PORTA2                       | PORTA1 | PORTA0 | 87      |
| 0x01 (0x21) | DDRA     | DDA7                         | DDA6   | DDA5   | DDA4   | DDA3   | DDA2                         | DDA1   | DDA0   | 87      |
| 0x00 (0x20) | PINA     | PINA7                        | PINA6  | PINA5  | PINA4  | PINA3  | PINA2                        | PINA1  | PINA0  | 87      |

- Note:
- For compatibility with future devices, reserved bits should be written to zero if accessed. Reserved I/O memory addresses should never be written.
  - I/O Registers within the address range 0x00 - 0x1F are directly bit-accessible using the SBI and CBI instructions. In these registers, the value of single bits can be checked by using the SBIS and SBIC instructions.
  - Some of the Status Flags are cleared by writing a logical one to them. Note that, unlike most other AVR, the CBI and SBI instructions will only operate on the specified bit, and can therefore be used on registers containing such Status Flags. The CBI and SBI instructions work with registers 0x00 to 0x1F only.
  - When using the I/O specific commands IN and OUT, the I/O addresses 0x00 - 0x3F must be used. When addressing I/O Registers as data space using LD and ST instructions, 0x20 must be added to these addresses. The ATmega329/3290/649/6490 is a complex microcontroller with more peripheral units than can be supported within the 64 location reserved in Opcode for the IN and OUT instructions. For the Extended I/O space from 0x60 - 0xFF in SRAM, only the ST/STS/STD and LD/LDS/LDD instructions can be used.

## 7. Instruction Set Summary

| Mnemonics                                | Operands | Description                              | Operation   | Flags         | #Clocks |
|--|----------|--|---|---------------|---------|
| <b>ARITHMETIC AND LOGIC INSTRUCTIONS</b> |          |  |   |               |         |
| ADD                                      | Rd, Rr   | Add two Registers                        | $Rd \leftarrow Rd + Rr$                               | Z,C,N,V,H     | 1       |
| ADC                                      | Rd, Rr   | Add with Carry two Registers             | $Rd \leftarrow Rd + Rr + C$                           | Z,C,N,V,H     | 1       |
| ADIW                                     | Rd,K     | Add Immediate to Word                    | $Rdh:Rdl \leftarrow Rdh:Rdl + K$                      | Z,C,N,V,S     | 2       |
| SUB                                      | Rd, Rr   | Subtract two Registers                   | $Rd \leftarrow Rd - Rr$                               | Z,C,N,V,H     | 1       |
| SUBI                                     | Rd, K    | Subtract Constant from Register          | $Rd \leftarrow Rd - K$                                | Z,C,N,V,H     | 1       |
| SBC                                      | Rd, Rr   | Subtract with Carry two Registers        | $Rd \leftarrow Rd - Rr - C$                           | Z,C,N,V,H     | 1       |
| SBCI                                     | Rd, K    | Subtract with Carry Constant from Reg.   | $Rd \leftarrow Rd - K - C$                            | Z,C,N,V,H     | 1       |
| SBIW                                     | Rd,K     | Subtract Immediate from Word             | $Rdh:Rdl \leftarrow Rdh:Rdl - K$                      | Z,C,N,V,S     | 2       |
| AND                                      | Rd, Rr   | Logical AND Registers                    | $Rd \leftarrow Rd \bullet Rr$                         | Z,N,V         | 1       |
| ANDI                                     | Rd, K    | Logical AND Register and Constant        | $Rd \leftarrow Rd \bullet K$                          | Z,N,V         | 1       |
| OR                                       | Rd, Rr   | Logical OR Registers                     | $Rd \leftarrow Rd \vee Rr$                            | Z,N,V         | 1       |
| ORI                                      | Rd, K    | Logical OR Register and Constant         | $Rd \leftarrow Rd \vee K$                             | Z,N,V         | 1       |
| EOR                                      | Rd, Rr   | Exclusive OR Registers                   | $Rd \leftarrow Rd \oplus Rr$                          | Z,N,V         | 1       |
| COM                                      | Rd       | One's Complement                         | $Rd \leftarrow 0xFF - Rd$                             | Z,C,N,V       | 1       |
| NEG                                      | Rd       | Two's Complement                         | $Rd \leftarrow 0x00 - Rd$                             | Z,C,N,V,H     | 1       |
| SBR                                      | Rd,K     | Set Bit(s) in Register                   | $Rd \leftarrow Rd \vee K$                             | Z,N,V         | 1       |
| CBR                                      | Rd,K     | Clear Bit(s) in Register                 | $Rd \leftarrow Rd \bullet (0xFF - K)$                 | Z,N,V         | 1       |
| INC                                      | Rd       | Increment                                | $Rd \leftarrow Rd + 1$                                | Z,N,V         | 1       |
| DEC                                      | Rd       | Decrement                                | $Rd \leftarrow Rd - 1$                                | Z,N,V         | 1       |
| TST                                      | Rd       | Test for Zero or Minus                   | $Rd \leftarrow Rd \bullet Rd$                         | Z,N,V         | 1       |
| CLR                                      | Rd       | Clear Register                           | $Rd \leftarrow Rd \oplus Rd$                          | Z,N,V         | 1       |
| SER                                      | Rd       | Set Register                             | $Rd \leftarrow 0xFF$                                  | None          | 1       |
| MUL                                      | Rd, Rr   | Multiply Unsigned                        | $R1:R0 \leftarrow Rd \times Rr$                       | Z,C           | 2       |
| MULS                                     | Rd, Rr   | Multiply Signed                          | $R1:R0 \leftarrow Rd \times Rr$                       | Z,C           | 2       |
| MULSU                                    | Rd, Rr   | Multiply Signed with Unsigned            | $R1:R0 \leftarrow Rd \times Rr$                       | Z,C           | 2       |
| FMUL                                     | Rd, Rr   | Fractional Multiply Unsigned             | $R1:R0 \leftarrow (Rd \times Rr) \lll 1$              | Z,C           | 2       |
| FMULS                                    | Rd, Rr   | Fractional Multiply Signed               | $R1:R0 \leftarrow (Rd \times Rr) \lll 1$              | Z,C           | 2       |
| FMULSU                                   | Rd, Rr   | Fractional Multiply Signed with Unsigned | $R1:R0 \leftarrow (Rd \times Rr) \lll 1$              | Z,C           | 2       |
| <b>BRANCH INSTRUCTIONS</b>               |          |  |   |               |         |
| RJMP                                     | k        | Relative Jump                            | $PC \leftarrow PC + k + 1$                            | None          | 2       |
| IJMP                                     |          | Indirect Jump to (Z)                     | $PC \leftarrow Z$                                     | None          | 2       |
| JMP                                      | k        | Direct Jump                              | $PC \leftarrow k$                                     | None          | 3       |
| RCALL                                    | k        | Relative Subroutine Call                 | $PC \leftarrow PC + k + 1$                            | None          | 3       |
| ICALL                                    |          | Indirect Call to (Z)                     | $PC \leftarrow Z$                                     | None          | 3       |
| CALL                                     | k        | Direct Subroutine Call                   | $PC \leftarrow k$                                     | None          | 4       |
| RET                                      |          | Subroutine Return                        | $PC \leftarrow STACK$                                 | None          | 4       |
| RETI                                     |          | Interrupt Return                         | $PC \leftarrow STACK$                                 | I             | 4       |
| CPSE                                     | Rd,Rr    | Compare, Skip if Equal                   | if $(Rd = Rr)$ $PC \leftarrow PC + 2$ or 3            | None          | 1/2/3   |
| CP                                       | Rd,Rr    | Compare                                  | $Rd - Rr$   | Z, N, V, C, H | 1       |
| CPC                                      | Rd,Rr    | Compare with Carry                       | $Rd - Rr - C$   | Z, N, V, C, H | 1       |
| CPI                                      | Rd,K     | Compare Register with Immediate          | $Rd - K$  | Z, N, V, C, H | 1       |
| SBRC                                     | Rr, b    | Skip if Bit in Register Cleared          | if $(Rr(b)=0)$ $PC \leftarrow PC + 2$ or 3            | None          | 1/2/3   |
| SBRS                                     | Rr, b    | Skip if Bit in Register is Set           | if $(Rr(b)=1)$ $PC \leftarrow PC + 2$ or 3            | None          | 1/2/3   |
| SBIC                                     | P, b     | Skip if Bit in I/O Register Cleared      | if $(P(b)=0)$ $PC \leftarrow PC + 2$ or 3             | None          | 1/2/3   |
| SBIS                                     | P, b     | Skip if Bit in I/O Register is Set       | if $(P(b)=1)$ $PC \leftarrow PC + 2$ or 3             | None          | 1/2/3   |
| BRBS                                     | s, k     | Branch if Status Flag Set                | if $(SREG(s) = 1)$ then $PC \leftarrow PC + k + 1$    | None          | 1/2     |
| BRBC                                     | s, k     | Branch if Status Flag Cleared            | if $(SREG(s) = 0)$ then $PC \leftarrow PC + k + 1$    | None          | 1/2     |
| BREQ                                     | k        | Branch if Equal                          | if $(Z = 1)$ then $PC \leftarrow PC + k + 1$          | None          | 1/2     |
| BRNE                                     | k        | Branch if Not Equal                      | if $(Z = 0)$ then $PC \leftarrow PC + k + 1$          | None          | 1/2     |
| BRCS                                     | k        | Branch if Carry Set                      | if $(C = 1)$ then $PC \leftarrow PC + k + 1$          | None          | 1/2     |
| BRCC                                     | k        | Branch if Carry Cleared                  | if $(C = 0)$ then $PC \leftarrow PC + k + 1$          | None          | 1/2     |
| BRSH                                     | k        | Branch if Same or Higher                 | if $(C = 0)$ then $PC \leftarrow PC + k + 1$          | None          | 1/2     |
| BRLO                                     | k        | Branch if Lower                          | if $(C = 1)$ then $PC \leftarrow PC + k + 1$          | None          | 1/2     |
| BRMI                                     | k        | Branch if Minus                          | if $(N = 1)$ then $PC \leftarrow PC + k + 1$          | None          | 1/2     |
| BRPL                                     | k        | Branch if Plus                           | if $(N = 0)$ then $PC \leftarrow PC + k + 1$          | None          | 1/2     |
| BRGE                                     | k        | Branch if Greater or Equal, Signed       | if $(N \oplus V = 0)$ then $PC \leftarrow PC + k + 1$ | None          | 1/2     |
| BRLT                                     | k        | Branch if Less Than Zero, Signed         | if $(N \oplus V = 1)$ then $PC \leftarrow PC + k + 1$ | None          | 1/2     |
| BRHS                                     | k        | Branch if Half Carry Flag Set            | if $(H = 1)$ then $PC \leftarrow PC + k + 1$          | None          | 1/2     |
| BRHC                                     | k        | Branch if Half Carry Flag Cleared        | if $(H = 0)$ then $PC \leftarrow PC + k + 1$          | None          | 1/2     |
| BRTS                                     | k        | Branch if T Flag Set                     | if $(T = 1)$ then $PC \leftarrow PC + k + 1$          | None          | 1/2     |

| Mnemonics                            | Operands | Description                        | Operation                                | Flags   | #Clocks |
|--------------------------------------|----------|------------------------------------|--|---------|---------|
| BRTC                                 | k        | Branch if T Flag Cleared           | if (T = 0) then PC ← PC + k + 1          | None    | 1/2     |
| BRVS                                 | k        | Branch if Overflow Flag is Set     | if (V = 1) then PC ← PC + k + 1          | None    | 1/2     |
| BRVC                                 | k        | Branch if Overflow Flag is Cleared | if (V = 0) then PC ← PC + k + 1          | None    | 1/2     |
| BRIE                                 | k        | Branch if Interrupt Enabled        | if (I = 1) then PC ← PC + k + 1          | None    | 1/2     |
| BRID                                 | k        | Branch if Interrupt Disabled       | if (I = 0) then PC ← PC + k + 1          | None    | 1/2     |
| <b>BIT AND BIT-TEST INSTRUCTIONS</b> |          |                                    |  |         |         |
| SBI                                  | P,b      | Set Bit in I/O Register            | I/O(P,b) ← 1                             | None    | 2       |
| CBI                                  | P,b      | Clear Bit in I/O Register          | I/O(P,b) ← 0                             | None    | 2       |
| LSL                                  | Rd       | Logical Shift Left                 | Rd(n+1) ← Rd(n), Rd(0) ← 0               | Z,C,N,V | 1       |
| LSR                                  | Rd       | Logical Shift Right                | Rd(n) ← Rd(n+1), Rd(7) ← 0               | Z,C,N,V | 1       |
| ROL                                  | Rd       | Rotate Left Through Carry          | Rd(0) ← C, Rd(n+1) ← Rd(n), C ← Rd(7)    | Z,C,N,V | 1       |
| ROR                                  | Rd       | Rotate Right Through Carry         | Rd(7) ← C, Rd(n) ← Rd(n+1), C ← Rd(0)    | Z,C,N,V | 1       |
| ASR                                  | Rd       | Arithmetic Shift Right             | Rd(n) ← Rd(n+1), n=0..6                  | Z,C,N,V | 1       |
| SWAP                                 | Rd       | Swap Nibbles                       | Rd(3..0) ← Rd(7..4), Rd(7..4) ← Rd(3..0) | None    | 1       |
| BSET                                 | s        | Flag Set                           | SREG(s) ← 1                              | SREG(s) | 1       |
| BCLR                                 | s        | Flag Clear                         | SREG(s) ← 0                              | SREG(s) | 1       |
| BST                                  | Rr, b    | Bit Store from Register to T       | T ← Rr(b)                                | T       | 1       |
| BLD                                  | Rd, b    | Bit load from T to Register        | Rd(b) ← T                                | None    | 1       |
| SEC                                  |          | Set Carry                          | C ← 1                                    | C       | 1       |
| CLC                                  |          | Clear Carry                        | C ← 0                                    | C       | 1       |
| SEN                                  |          | Set Negative Flag                  | N ← 1                                    | N       | 1       |
| CLN                                  |          | Clear Negative Flag                | N ← 0                                    | N       | 1       |
| SEZ                                  |          | Set Zero Flag                      | Z ← 1                                    | Z       | 1       |
| CLZ                                  |          | Clear Zero Flag                    | Z ← 0                                    | Z       | 1       |
| SEI                                  |          | Global Interrupt Enable            | I ← 1                                    | I       | 1       |
| CLI                                  |          | Global Interrupt Disable           | I ← 0                                    | I       | 1       |
| SES                                  |          | Set Signed Test Flag               | S ← 1                                    | S       | 1       |
| CLS                                  |          | Clear Signed Test Flag             | S ← 0                                    | S       | 1       |
| SEV                                  |          | Set Twos Complement Overflow.      | V ← 1                                    | V       | 1       |
| CLV                                  |          | Clear Twos Complement Overflow     | V ← 0                                    | V       | 1       |
| SET                                  |          | Set T in SREG                      | T ← 1                                    | T       | 1       |
| CLT                                  |          | Clear T in SREG                    | T ← 0                                    | T       | 1       |
| SEH                                  |          | Set Half Carry Flag in SREG        | H ← 1                                    | H       | 1       |
| CLH                                  |          | Clear Half Carry Flag in SREG      | H ← 0                                    | H       | 1       |
| <b>DATA TRANSFER INSTRUCTIONS</b>    |          |                                    |  |         |         |
| MOV                                  | Rd, Rr   | Move Between Registers             | Rd ← Rr                                  | None    | 1       |
| MOVW                                 | Rd, Rr   | Copy Register Word                 | Rd+1:Rd ← Rr+1:Rr                        | None    | 1       |
| LDI                                  | Rd, K    | Load Immediate                     | Rd ← K                                   | None    | 1       |
| LD                                   | Rd, X    | Load Indirect                      | Rd ← (X)                                 | None    | 2       |
| LD                                   | Rd, X+   | Load Indirect and Post-Inc.        | Rd ← (X), X ← X + 1                      | None    | 2       |
| LD                                   | Rd, -X   | Load Indirect and Pre-Dec.         | X ← X - 1, Rd ← (X)                      | None    | 2       |
| LD                                   | Rd, Y    | Load Indirect                      | Rd ← (Y)                                 | None    | 2       |
| LD                                   | Rd, Y+   | Load Indirect and Post-Inc.        | Rd ← (Y), Y ← Y + 1                      | None    | 2       |
| LD                                   | Rd, -Y   | Load Indirect and Pre-Dec.         | Y ← Y - 1, Rd ← (Y)                      | None    | 2       |
| LDD                                  | Rd, Y+q  | Load Indirect with Displacement    | Rd ← (Y + q)                             | None    | 2       |
| LD                                   | Rd, Z    | Load Indirect                      | Rd ← (Z)                                 | None    | 2       |
| LD                                   | Rd, Z+   | Load Indirect and Post-Inc.        | Rd ← (Z), Z ← Z+1                        | None    | 2       |
| LD                                   | Rd, -Z   | Load Indirect and Pre-Dec.         | Z ← Z - 1, Rd ← (Z)                      | None    | 2       |
| LDD                                  | Rd, Z+q  | Load Indirect with Displacement    | Rd ← (Z + q)                             | None    | 2       |
| LDS                                  | Rd, k    | Load Direct from SRAM              | Rd ← (k)                                 | None    | 2       |
| ST                                   | X, Rr    | Store Indirect                     | (X) ← Rr                                 | None    | 2       |
| ST                                   | X+, Rr   | Store Indirect and Post-Inc.       | (X) ← Rr, X ← X + 1                      | None    | 2       |
| ST                                   | -X, Rr   | Store Indirect and Pre-Dec.        | X ← X - 1, (X) ← Rr                      | None    | 2       |
| ST                                   | Y, Rr    | Store Indirect                     | (Y) ← Rr                                 | None    | 2       |
| ST                                   | Y+, Rr   | Store Indirect and Post-Inc.       | (Y) ← Rr, Y ← Y + 1                      | None    | 2       |
| ST                                   | -Y, Rr   | Store Indirect and Pre-Dec.        | Y ← Y - 1, (Y) ← Rr                      | None    | 2       |
| STD                                  | Y+q,Rr   | Store Indirect with Displacement   | (Y + q) ← Rr                             | None    | 2       |
| ST                                   | Z, Rr    | Store Indirect                     | (Z) ← Rr                                 | None    | 2       |
| ST                                   | Z+, Rr   | Store Indirect and Post-Inc.       | (Z) ← Rr, Z ← Z + 1                      | None    | 2       |
| ST                                   | -Z, Rr   | Store Indirect and Pre-Dec.        | Z ← Z - 1, (Z) ← Rr                      | None    | 2       |
| STD                                  | Z+q,Rr   | Store Indirect with Displacement   | (Z + q) ← Rr                             | None    | 2       |
| STS                                  | k, Rr    | Store Direct to SRAM               | (k) ← Rr                                 | None    | 2       |
| LPM                                  |          | Load Program Memory                | R0 ← (Z)                                 | None    | 3       |
| LPM                                  | Rd, Z    | Load Program Memory                | Rd ← (Z)                                 | None    | 3       |
| LPM                                  | Rd, Z+   | Load Program Memory and Post-Inc   | Rd ← (Z), Z ← Z+1                        | None    | 3       |
| SPM                                  |          | Store Program Memory               | (Z) ← R1:R0                              | None    | -       |





| Mnemonics                       | Operands | Description             | Operation                                | Flags | #Clocks |
|---------------------------------|----------|-------------------------|--|-------|---------|
| IN                              | Rd, P    | In Port                 | Rd ← P                                   | None  | 1       |
| OUT                             | P, Rr    | Out Port                | P ← Rr                                   | None  | 1       |
| PUSH                            | Rr       | Push Register on Stack  | STACK ← Rr                               | None  | 2       |
| POP                             | Rd       | Pop Register from Stack | Rd ← STACK                               | None  | 2       |
| <b>MCU CONTROL INSTRUCTIONS</b> |          |                         |  |       |         |
| NOP                             |          | No Operation            |  | None  | 1       |
| SLEEP                           |          | Sleep                   | (see specific descr. for Sleep function) | None  | 1       |
| WDR                             |          | Watchdog Reset          | (see specific descr. for WDR/timer)      | None  | 1       |
| BREAK                           |          | Break                   | For On-chip Debug Only                   | None  | N/A     |





## 8. Ordering Information

### 8.1 ATmega329

| Speed (MHz) <sup>(3)</sup> | Power Supply | Ordering Code  | Package Type <sup>(1)</sup> | Operational Range             |
|----------------------------|--------------|--|-----------------------------|-------------------------------|
| 8                          | 1.8 - 5.5V   | ATmega329V-8AI<br>ATmega329V-8AU <sup>(2)</sup><br>ATmega329V-8MI<br>ATmega329V-8MU <sup>(2)</sup> | 64A<br>64A<br>64M1<br>64M1  | Industrial<br>(-40°C to 85°C) |
| 16                         | 2.7 - 5.5V   | ATmega329-16AI<br>ATmega329-16AU <sup>(2)</sup><br>ATmega329-16MI<br>ATmega329-16MU <sup>(2)</sup> | 64A<br>64A<br>64M1<br>64M1  | Industrial<br>(-40°C to 85°C) |

- Notes:
1. This device can also be supplied in wafer form. Please contact your local Atmel sales office for detailed ordering information and minimum quantities.
  2. Pb-free packaging alternative, complies to the European Directive for Restriction of Hazardous Substances (RoHS directive). Also Halide free and fully Green.
  3. For Speed vs.  $V_{CC}$  see [Figure 29-1 on page 328](#) and [Figure 29-2 on page 328](#).

| Package Type |  |
|--------------|--|
| <b>64A</b>   | 64-lead, 14 x 14 x 1.0 mm, Thin Profile Plastic Quad Flat Package (TQFP)                     |
| <b>64M1</b>  | 64-pad, 9 x 9 x 1.0 mm, Quad Flat No-Lead/Micro Lead Frame Package (QFN/MLF)                 |
| <b>100A</b>  | 100-lead, 14 x 14 x 1.0 mm, 0.5 mm Lead Pitch, Thin Profile Plastic Quad Flat Package (TQFP) |



## 8.2 ATmega3290

| Speed (MHz) <sup>(3)</sup> | Power Supply | Ordering Code                                     | Package Type <sup>(1)</sup> | Operational Range             |
|----------------------------|--------------|---|-----------------------------|-------------------------------|
| 8                          | 1.8 - 5.5V   | ATmega3290V-8AI<br>ATmega3290V-8AU <sup>(2)</sup> | 100A<br>100A                | Industrial<br>(-40°C to 85°C) |
| 16                         | 2.7 - 5.5V   | ATmega3290-16AI<br>ATmega3290-16AU <sup>(2)</sup> | 100A<br>100A                | Industrial<br>(-40°C to 85°C) |

- Notes:
1. This device can also be supplied in wafer form. Please contact your local Atmel sales office for detailed ordering information and minimum quantities.
  2. Pb-free packaging alternative, complies to the European Directive for Restriction of Hazardous Substances (RoHS directive). Also Halide free and fully Green.
  3. For Speed vs.  $V_{CC}$  see [Figure 29-1 on page 328](#) and [Figure 29-2 on page 328](#).

| Package Type |  |
|--------------|--|
| <b>64A</b>   | 64-lead, 14 x 14 x 1.0 mm, Thin Profile Plastic Quad Flat Package (TQFP)                     |
| <b>64M1</b>  | 64-pad, 9 x 9 x 1.0 mm, Quad Flat No-Lead/Micro Lead Frame Package (QFN/MLF)                 |
| <b>100A</b>  | 100-lead, 14 x 14 x 1.0 mm, 0.5 mm Lead Pitch, Thin Profile Plastic Quad Flat Package (TQFP) |

## 8.3 ATmega649

| Speed (MHz) <sup>(3)</sup> | Power Supply | Ordering Code  | Package Type <sup>(1)</sup> | Operational Range             |
|----------------------------|--------------|--|-----------------------------|-------------------------------|
| 8                          | 1.8 - 5.5V   | ATmega649V-8AI<br>ATmega649V-8AU <sup>(2)</sup><br>ATmega649V-8MI<br>ATmega649V-8MU <sup>(2)</sup> | 64A<br>64A<br>64M1<br>64M1  | Industrial<br>(-40°C to 85°C) |
| 16                         | 2.7 - 5.5V   | ATmega649-16AI<br>ATmega649-16AU <sup>(2)</sup><br>ATmega649-16MI<br>ATmega649-16MU <sup>(2)</sup> | 64A<br>64A<br>64M1<br>64M1  | Industrial<br>(-40°C to 85°C) |

- Notes:
1. This device can also be supplied in wafer form. Please contact your local Atmel sales office for detailed ordering information and minimum quantities.
  2. Pb-free packaging alternative, complies to the European Directive for Restriction of Hazardous Substances (RoHS directive). Also Halide free and fully Green.
  3. For Speed vs.  $V_{CC}$  see [Figure 29-1 on page 328](#) and [Figure 29-2 on page 328](#).

| Package Type |  |
|--------------|--|
| <b>64A</b>   | 64-lead, 14 x 14 x 1.0 mm, Thin Profile Plastic Quad Flat Package (TQFP)                     |
| <b>64M1</b>  | 64-pad, 9 x 9 x 1.0 mm, Quad Flat No-Lead/Micro Lead Frame Package (QFN/MLF)                 |
| <b>100A</b>  | 100-lead, 14 x 14 x 1.0 mm, 0.5 mm Lead Pitch, Thin Profile Plastic Quad Flat Package (TQFP) |



## 8.4 ATmega6490

| Speed (MHz) <sup>(3)</sup> | Power Supply | Ordering Code                                     | Package Type <sup>(1)</sup> | Operational Range             |
|----------------------------|--------------|---|-----------------------------|-------------------------------|
| 8                          | 1.8 - 5.5V   | ATmega6490V-8AI<br>ATmega6490V-8AU <sup>(2)</sup> | 100A<br>100A                | Industrial<br>(-40°C to 85°C) |
| 16                         | 2.7 - 5.5V   | ATmega6490-16AI<br>ATmega6490-16AU <sup>(2)</sup> | 100A<br>100A                | Industrial<br>(-40°C to 85°C) |

- Notes:
1. This device can also be supplied in wafer form. Please contact your local Atmel sales office for detailed ordering information and minimum quantities.
  2. Pb-free packaging alternative, complies to the European Directive for Restriction of Hazardous Substances (RoHS directive). Also Halide free and fully Green.
  3. For Speed Grades see [Figure 29-1 on page 328](#) and [Figure 29-2 on page 328](#).

| Package Type |  |
|--------------|--|
| <b>64A</b>   | 64-lead, 14 x 14 x 1.0 mm, Thin Profile Plastic Quad Flat Package (TQFP)                     |
| <b>64M1</b>  | 64-pad, 9 x 9 x 1.0 mm, Quad Flat No-Lead/Micro Lead Frame Package (QFN/MLF)                 |
| <b>100A</b>  | 100-lead, 14 x 14 x 1.0 mm, 0.5 mm Lead Pitch, Thin Profile Plastic Quad Flat Package (TQFP) |

## 9. Packaging Information

### 9.1 64A

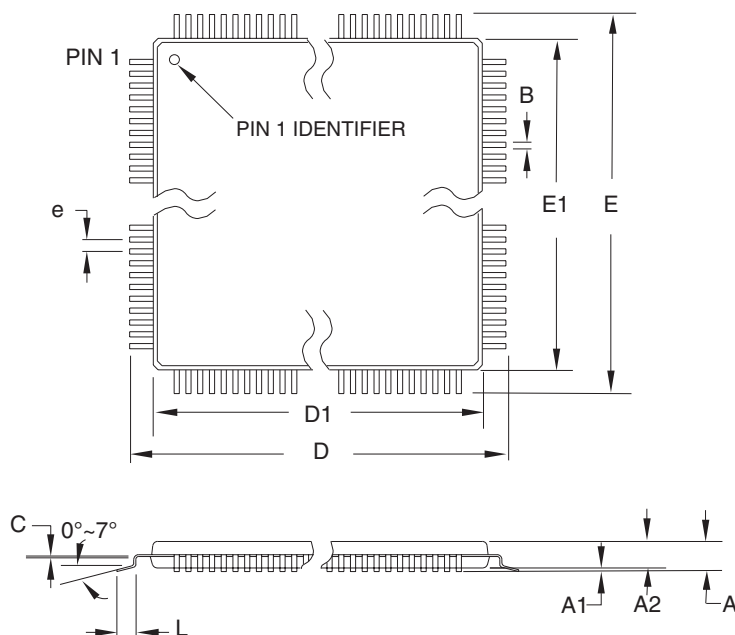

**COMMON DIMENSIONS**  
(Unit of Measure = mm)

| SYMBOL | MIN      | NOM   | MAX   | NOTE   |
|--------|----------|-------|-------|--------|
| A      | –        | –     | 1.20  |        |
| A1     | 0.05     | –     | 0.15  |        |
| A2     | 0.95     | 1.00  | 1.05  |        |
| D      | 15.75    | 16.00 | 16.25 |        |
| D1     | 13.90    | 14.00 | 14.10 | Note 2 |
| E      | 15.75    | 16.00 | 16.25 |        |
| E1     | 13.90    | 14.00 | 14.10 | Note 2 |
| B      | 0.30     | –     | 0.45  |        |
| C      | 0.09     | –     | 0.20  |        |
| L      | 0.45     | –     | 0.75  |        |
| e      | 0.80 TYP |       |       |        |

**Notes:**

1. This package conforms to JEDEC reference MS-026, Variation AEB.
2. Dimensions D1 and E1 do not include mold protrusion. Allowable protrusion is 0.25 mm per side. Dimensions D1 and E1 are maximum plastic body size dimensions including mold mismatch.
3. Lead coplanarity is 0.10 mm maximum.

10/5/2001



2325 Orchard Parkway  
San Jose, CA 95131

**TITLE**

**64A**, 64-lead, 14 x 14 mm Body Size, 1.0 mm Body Thickness,  
0.8 mm Lead Pitch, Thin Profile Plastic Quad Flat Package (TQFP)

**DRAWING NO.**

64A

**REV.**

B



9.2 64M1

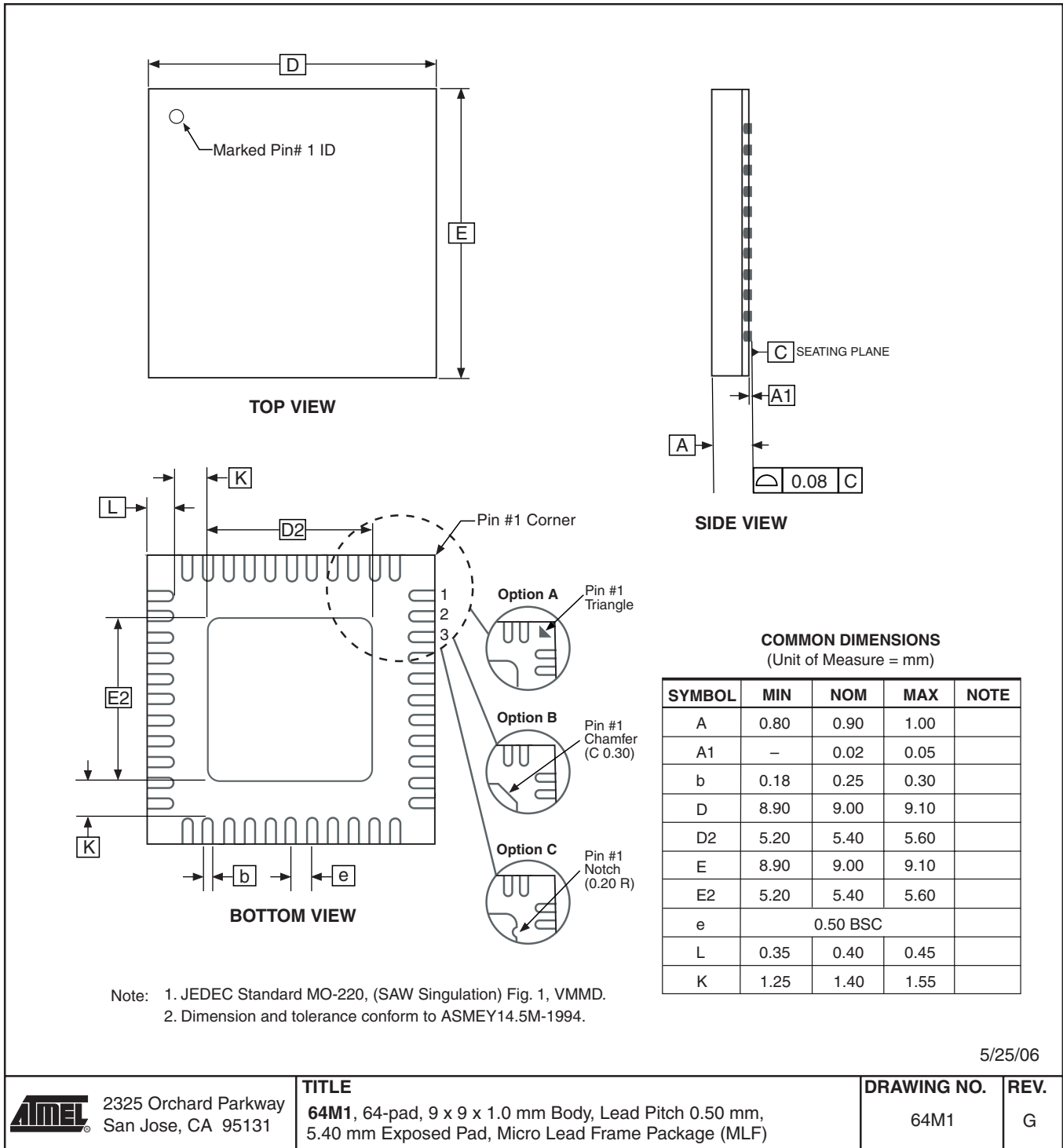

## 9.3 100A

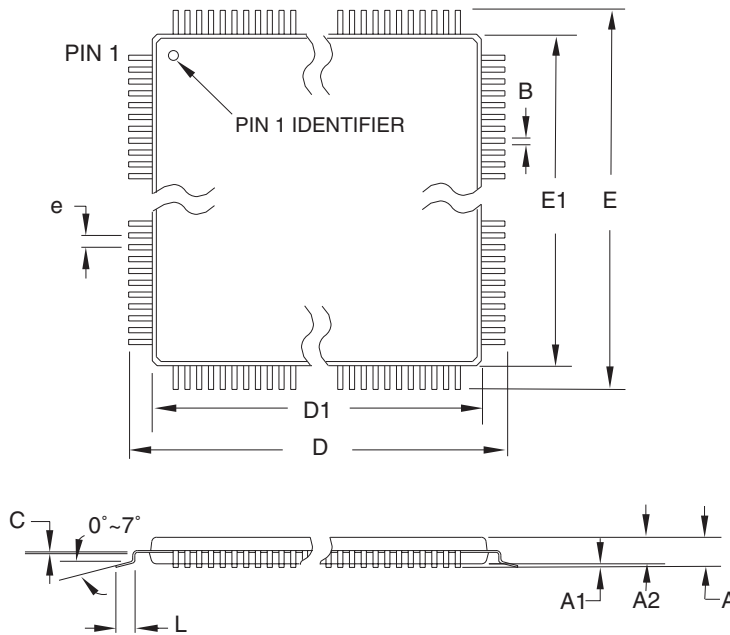

**COMMON DIMENSIONS**  
(Unit of Measure = mm)

| SYMBOL | MIN      | NOM   | MAX   | NOTE   |
|--------|----------|-------|-------|--------|
| A      | –        | –     | 1.20  |        |
| A1     | 0.05     | –     | 0.15  |        |
| A2     | 0.95     | 1.00  | 1.05  |        |
| D      | 15.75    | 16.00 | 16.25 |        |
| D1     | 13.90    | 14.00 | 14.10 | Note 2 |
| E      | 15.75    | 16.00 | 16.25 |        |
| E1     | 13.90    | 14.00 | 14.10 | Note 2 |
| B      | 0.17     | –     | 0.27  |        |
| C      | 0.09     | –     | 0.20  |        |
| L      | 0.45     | –     | 0.75  |        |
| e      | 0.50 TYP |       |       |        |

- Notes:
1. This package conforms to JEDEC reference MS-026, Variation AED.
  2. Dimensions D1 and E1 do not include mold protrusion. Allowable protrusion is 0.25 mm per side. Dimensions D1 and E1 are maximum plastic body size dimensions including mold mismatch.
  3. Lead coplanarity is 0.08 mm maximum.

10/5/2001



2325 Orchard Parkway  
San Jose, CA 95131

**TITLE**

**100A**, 100-lead, 14 x 14 mm Body Size, 1.0 mm Body Thickness,  
0.5 mm Lead Pitch, Thin Profile Plastic Quad Flat Package (TQFP)

**DRAWING NO.**

100A

**REV.**

C



## 10. Errata

### 10.1 ATmega329

#### 10.1.1 ATmega329 rev. C

- **Interrupts may be lost when writing the timer registers in the asynchronous timer**

##### 1. **Interrupts may be lost when writing the timer registers in the asynchronous timer**

If one of the timer registers which is synchronized to the asynchronous timer2 clock is written in the cycle before a overflow interrupt occurs, the interrupt may be lost.

##### **Problem Fix/Workaround**

Always check that the Timer2 Timer/Counter register, TCNT2, does not have the value 0xFF before writing the Timer2 Control Register, TCCR2, or Output Compare Register, OCR2.

#### 10.1.2 ATmega329 rev. B

Not sampled.

#### 10.1.3 ATmega329 rev. A

- **LCD contrast voltage too high**
- **Interrupts may be lost when writing the timer registers in the asynchronous timer**

##### 1. **LCD contrast voltage too high**

When the LCD is active and using low power waveform, the LCD contrast voltage can be too high. This occurs when  $V_{CC}$  is higher than  $V_{LCD}$ , and when using low LCD drivetime.

##### **Problem Fix/Workaround**

There are several possible workarounds:

- Use normal waveform instead of low power waveform
- Use drivetime of 375  $\mu$ s or longer

##### 2. **Interrupts may be lost when writing the timer registers in the asynchronous timer**

If one of the timer registers which is synchronized to the asynchronous timer2 clock is written in the cycle before a overflow interrupt occurs, the interrupt may be lost.

##### **Problem Fix/Workaround**

Always check that the Timer2 Timer/Counter register, TCNT2, does not have the value 0xFF before writing the Timer2 Control Register, TCCR2, or Output Compare Register, OCR2.



## 10.2 ATmega3290

### 10.2.1 ATmega3290 rev. C

- Interrupts may be lost when writing the timer registers in the asynchronous timer

#### 1. Interrupts may be lost when writing the timer registers in the asynchronous timer

If one of the timer registers which is synchronized to the asynchronous timer2 clock is written in the cycle before a overflow interrupt occurs, the interrupt may be lost.

##### **Problem Fix/Workaround**

Always check that the Timer2 Timer/Counter register, TCNT2, does not have the value 0xFF before writing the Timer2 Control Register, TCCR2, or Output Compare Register, OCR2.

### 10.2.2 ATmega3290 rev. B

Not sampled.

### 10.2.3 ATmega3290 rev. A

- LCD contrast voltage too high
- Interrupts may be lost when writing the timer registers in the asynchronous timer

#### 1. LCD contrast voltage too high

When the LCD is active and using low power waveform, the LCD contrast voltage can be too high. This occurs when  $V_{CC}$  is higher than  $V_{LCD}$ , and when using low LCD drivetime.

##### **Problem Fix/Workaround**

There are several possible workarounds:

- Use normal waveform instead of low power waveform
- Use drivetime of 375  $\mu$ s or longer

#### 2. Interrupts may be lost when writing the timer registers in the asynchronous timer

If one of the timer registers which is synchronized to the asynchronous timer2 clock is written in the cycle before a overflow interrupt occurs, the interrupt may be lost.

##### **Problem Fix/Workaround**

Always check that the Timer2 Timer/Counter register, TCNT2, does not have the value 0xFF before writing the Timer2 Control Register, TCCR2, or Output Compare Register, OCR2.

## 10.3 ATmega649

### 10.3.1 ATmega649 rev. A

- **Interrupts may be lost when writing the timer registers in the asynchronous timer**

1. **Interrupts may be lost when writing the timer registers in the asynchronous timer**

If one of the timer registers which is synchronized to the asynchronous timer2 clock is written in the cycle before a overflow interrupt occurs, the interrupt may be lost.

**Problem Fix/Wortkaround**

Always check that the Timer2 Timer/Counter register, TCNT2, does not have the value 0xFF before writing the Timer2 Control Register, TCCR2, or Output Compare Register, OCR2.

## 10.4 ATmega6490

### 10.4.1 ATmega6490 rev. A

- **Interrupts may be lost when writing the timer registers in the asynchronous timer**

1. **Interrupts may be lost when writing the timer registers in the asynchronous timer**

If one of the timer registers which is synchronized to the asynchronous timer2 clock is written in the cycle before a overflow interrupt occurs, the interrupt may be lost.

**Problem Fix/Wortkaround**

Always check that the Timer2 Timer/Counter register, TCNT2, does not have the value 0xFF before writing the Timer2 Control Register, TCCR2, or Output Compare Register, OCR2.

## 11. Datasheet Revision History

Please note that the referring page numbers in this section are referring to this document. The referring revision in this section are referring to the document revision.

### 11.1 Rev. 2552J – 08/07

1. Updated **“Features”** on page 1.
2. Added **“Data Retention”** on page 9.
3. Updated **“Serial Programming Algorithm”** on page 309.
4. Updated **“Speed Grades”** on page 328.
5. Updated **“System and Reset Characteristics”** on page 330.
6. Moved Register Descriptions to the end of each chapter.

### 11.2 Rev. 2552I – 04/07

1. Updated date in backpage
2. Updated column in **Table 29-5** on page 330.

### 11.3 Rev. 2552H – 11/06

1. Updated **Table 29-7** on page 333.
2. Updated note in **Table 29-7** on page 333 and **Table 29-2** on page 329.

### 11.4 Rev. 2552G – 07/06

1. Updated **Table 15-2** on page 104, **Table 15-4** on page 104, **Table 17-3** on page 133, **Table 17-5** on page 134, **Table 17-5** on page 134, **Table 18-2** on page 153 and **Table 18-4** on page 154.
2. Updated **“Fast PWM Mode”** on page 124.
3. Updated Features in **“USI – Universal Serial Interface”** on page 195.
4. Added **“Clock speed considerations.”** on page 202.
5. **“Errata”** on page 24.

### 11.5 Rev. 2552F – 06/06

1. Updated **“Calibrated Internal RC Oscillator”** on page 29.
2. Updated **“OSCCAL – Oscillator Calibration Register”** on page 32
3. Added **Table 29-2** on page 329.

## 11.6 Rev. 2552E – 04/06

1. Updated “Calibrated Internal RC Oscillator” on page 29.

## 11.7 Rev. 2552D – 03/06

1. Updated “Errata” on page 24.

## 11.8 Rev. 2552C – 03/06

1. Added “Resources” on page 9.
2. Added Addresses in Registers.
3. Updated number of General Purpose I/O pins.
4. Updated code example in “Bit 0 – IVCE: Interrupt Vector Change Enable” on page 53.
5. Updated Introduction in “I/O-Ports” on page 59.
6. Updated “SPI – Serial Peripheral Interface” on page 158.
7. Updated “Bit 6 – ACBG: Analog Comparator Bandgap Select” on page 209.
8. Updated Features in “Analog to Digital Converter” on page 211.
9. Updated “Prescaling and Conversion Timing” on page 214.
10. Updated features in “LCD Controller” on page 228.
11. Updated “ATmega329/3290/649/6490 Boot Loader Parameters” on page 290.
12. Updated “DC Characteristics” on page 310.
13. Updated “LCD Controller Characteristics – Preliminary Data – TBD” on page 334.

## 11.9 Rev. 2552B – 05/05

1. MLF-package alternative changed to “Quad Flat No-Lead/Micro Lead Frame Package QFN/MLF”.
2. Added “Pin Change Interrupt Timing” on page 54.
3. Updated Table 24-6 on page 242, Table 24-7 on page 243 and Table 28-15 on page 310.
4. Added Figure 28-12 on page 312.
5. Updated Figure 23-9 on page 219 and Figure 28-5 on page 304.
6. Updated algorithm “Enter Programming Mode” on page 299.
7. Added “Supply Current of I/O modules” on page 340.
8. Updated “Ordering Information” on page 17.

## 11.10 Rev. 2552A –11/04

1. Initial version.



## Headquarters

---

**Atmel Corporation**  
2325 Orchard Parkway  
San Jose, CA 95131  
USA  
Tel: 1(408) 441-0311  
Fax: 1(408) 487-2600

## International

---

**Atmel Asia**  
Room 1219  
Chinachem Golden Plaza  
77 Mody Road Tsimshatsui  
East Kowloon  
Hong Kong  
Tel: (852) 2721-9778  
Fax: (852) 2722-1369

**Atmel Europe**  
Le Krebs  
8, Rue Jean-Pierre Timbaud  
BP 309  
78054 Saint-Quentin-en-  
Yvelines Cedex  
France  
Tel: (33) 1-30-60-70-00  
Fax: (33) 1-30-60-71-11

**Atmel Japan**  
9F, Tonetsu Shinkawa Bldg.  
1-24-8 Shinkawa  
Chuo-ku, Tokyo 104-0033  
Japan  
Tel: (81) 3-3523-3551  
Fax: (81) 3-3523-7581

## Product Contact

---

**Web Site**  
[www.atmel.com](http://www.atmel.com)

**Technical Support**  
[avr@atmel.com](mailto:avr@atmel.com)

**Sales Contact**  
[www.atmel.com/contacts](http://www.atmel.com/contacts)

**Literature Requests**  
[www.atmel.com/literature](http://www.atmel.com/literature)

---

**Disclaimer:** The information in this document is provided in connection with Atmel products. No license, express or implied, by estoppel or otherwise, to any intellectual property right is granted by this document or in connection with the sale of Atmel products. **EXCEPT AS SET FORTH IN ATMEL'S TERMS AND CONDITIONS OF SALE LOCATED ON ATMEL'S WEB SITE, ATMEL ASSUMES NO LIABILITY WHATSOEVER AND DISCLAIMS ANY EXPRESS, IMPLIED OR STATUTORY WARRANTY RELATING TO ITS PRODUCTS INCLUDING, BUT NOT LIMITED TO, THE IMPLIED WARRANTY OF MERCHANTABILITY, FITNESS FOR A PARTICULAR PURPOSE, OR NON-INFRINGEMENT. IN NO EVENT SHALL ATMEL BE LIABLE FOR ANY DIRECT, INDIRECT, CONSEQUENTIAL, PUNITIVE, SPECIAL OR INCIDENTAL DAMAGES (INCLUDING, WITHOUT LIMITATION, DAMAGES FOR LOSS OF PROFITS, BUSINESS INTERRUPTION, OR LOSS OF INFORMATION) ARISING OUT OF THE USE OR INABILITY TO USE THIS DOCUMENT, EVEN IF ATMEL HAS BEEN ADVISED OF THE POSSIBILITY OF SUCH DAMAGES.** Atmel makes no representations or warranties with respect to the accuracy or completeness of the contents of this document and reserves the right to make changes to specifications and product descriptions at any time without notice. Atmel does not make any commitment to update the information contained herein. Unless specifically provided otherwise, Atmel products are not suitable for, and shall not be used in, automotive applications. Atmel's products are not intended, authorized, or warranted for use as components in applications intended to support or sustain life.

© 2007 Atmel Corporation. All rights reserved. Atmel®, logo and combinations thereof, AVR® and others are registered trademarks or trademarks of Atmel Corporation or its subsidiaries. Other terms and product names may be trademarks of others.