

320-640MHz Low Phase Noise VCXO

FEATURES

- Less than 0.4ps RMS (12KHz-20MHz) phase jitter for all frequencies.
- Low phase noise output (@ 1MHz frequency offset)
 - * -140dBc/Hz for 320.0MHz,
 - * -131dBc/Hz for 622.08MHz
- 20MHz-40MHz crystal input.
- 320MHz-640MHz output.
- PECL, or LVDS outputs.
- No external varicap required.
- Output Enable selector.
- Wide pull range (+/-200ppm).
- 3.3V operation.
- Available in 3x3 QFN or 16-pin TSSOP packages.

DESCRIPTION

The ABV806X is a monolithic low jitter and low phase noise VCXO, capable of 0.4ps RMS phase jitter and PECL or LVDS outputs, covering a wide frequency output range up to 640MHz. It allows the control of the output frequency with an input voltage (VCON), using a low cost crystal.

The ABV806X is designed to address the demanding requirements of high performance applications such as SONET, GPS, Video, etc.

PACKAGE PIN ASSIGNMENT

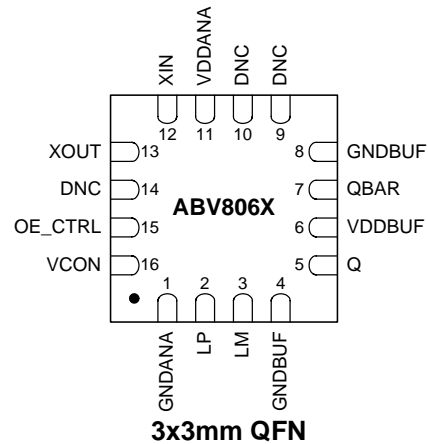
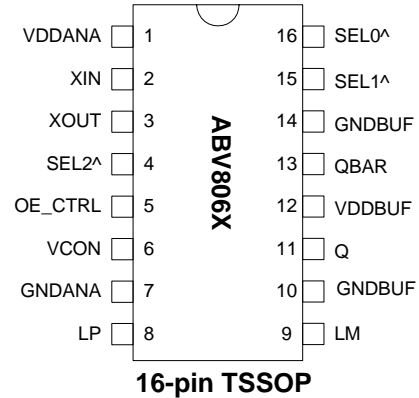

Note1: ^ Denotes internal pull up resistor.

BLOCK DIAGRAM

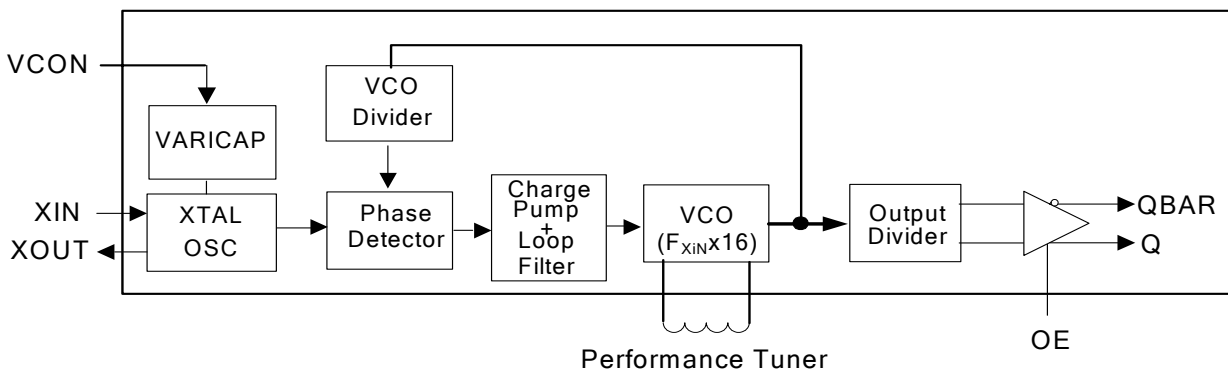

320-640MHz Low Phase Noise VCXO
OUTPUT ENABLE LOGICAL LEVELS

Part #	OE	State
ABV8068 (PECL)	0 (Default)	Output enabled
	1	Tri-state
ABV8069 (LVDS)	0	Tri-state
	1 (Default)	Output enabled

PIN DESCRIPTIONS

Name	TSSOP Pin number	3x3mm QFN Pin number	Type	Description
VDDANA	1	11	P	VDD for analog Circuitry.
XIN	2	12	I	Crystal input pin. (See Crystal Specifications on page 4).
XOUT	3	13	O	Crystal output pin. (See Crystal Specifications on page 4).
DNC	4	14	-	Do Not Connect
OE_CTRL	5	15	I	Output enable control pin. (See OE_CTRL Logic Levels above).
VCON	6	16	I	Voltage control input.
GNDANA	7	1	P	Ground for analog circuitry.
LP	8	2	-	Tuning inductor connection. The inductor is recommended to be a high Q small size 0402 or 0603 SMD component, and must be placed between LP and adjacent LM pin. Place inductor as close to the IC as possible to minimize parasitic effects and to maintain inductor Q.
LM	9	3	-	
GNDBUF	10	4	P	GND connection for output buffer circuitry.
Q	11	5	O	PECL or LVDS output.
VDDBUF	12	6	P	VDD connection for output buffer circuitry. VDDBUF should be separately decoupled from other VDDs whenever possible.
QBAR	13	7	O	Complementary PECL, LVDS output.
GNDBUF	14	8	P	GND connection for output buffer circuitry.
DNC	15	9	-	Do Not Connect
DNC	16	10	-	Do Not Connect

320-640MHz Low Phase Noise VCXO

FREQUENCY SELECTION TABLE

SEL2	SEL1	SEL0	Selected Multiplier/Output Frequency
0	0	0	VCO Max*
0	0	1	VCO Min*
1	1	1	Fin x 16
All Other Combinations			Reserved

All SEL pads have internal pull-ups (default value is '1'). Bond to GND to set to 0.
 * Special Test Modes to help selecting the inductor value for the target output frequency.

PERFORMANCE TUNING & INDUCTOR VALUE SELECTION

Please refer to Abracon's 'Tuning Assistance' software to automatically calculate the optimum inductor values for your application. In addition, the chart below could be used as a reference for quick inductor value selection. Please note that the inductor values mentioned in the table below, or when using the 'Tuning Assistance' are derived based on the parasitic values of Abracon's evaluation board. For performance enhancement of your custom board design, please follow the following instruction:

Use the special test modes "VCO Max" and "VCO Min" to determine the optimum inductor value. "VCO Max" represents the high end of the VCO range and "VCO Min" represents the low end of the VCO range. The output frequency in the "VCO Max" and "VCO Min" test modes is VCO/16. This means that the output frequencies are around the crystal frequency that will be used. The optimum inductor value is where the target crystal frequency is closest to the middle between the "VCO Max" and "VCO Min" output frequencies. In this case the VCO will lock in the middle of its tuning range with maximum margin on either side.

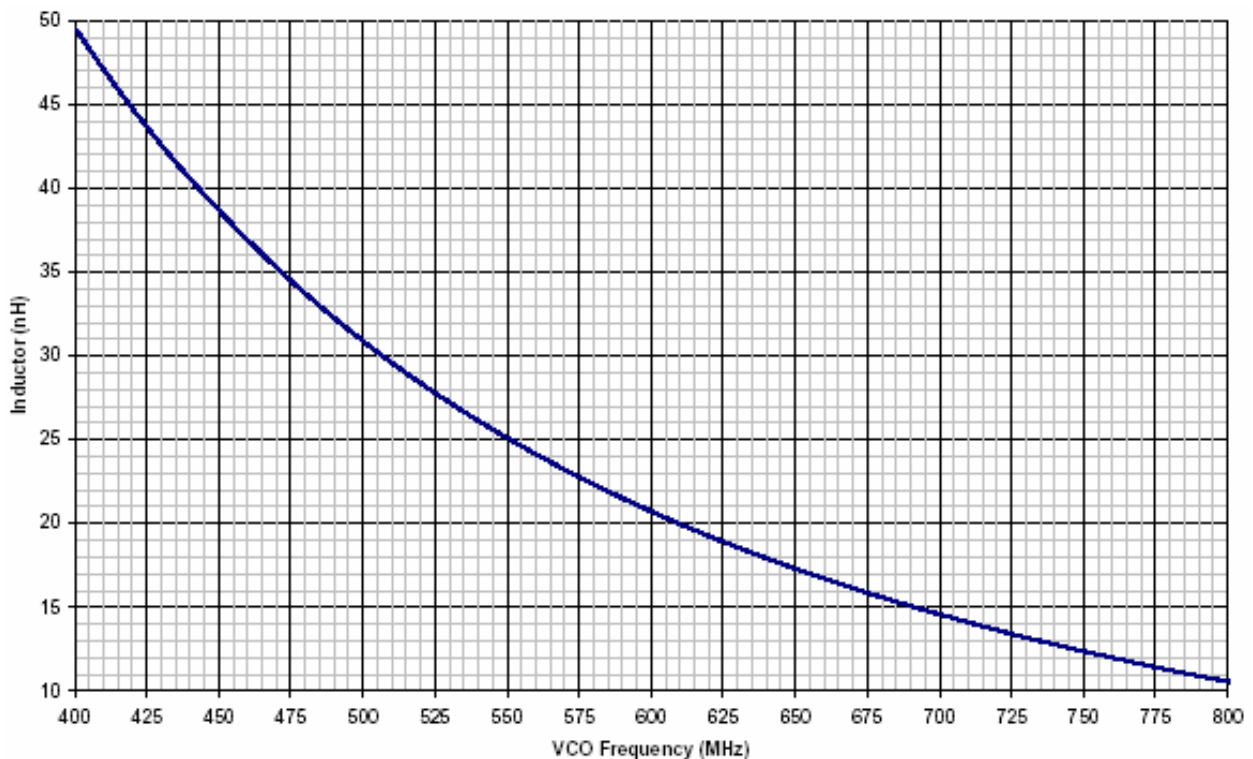

320-640MHz Low Phase Noise VCXO

ELECTRICAL SPECIFICATIONS

1. Absolute Maximum Ratings

PARAMETERS	SYMBOL	MIN.	MAX.	UNITS
Supply Voltage	V _{DD}		4.6	V
Input Voltage, dc	V _I	-0.5	V _{DD} +0.5	V
Output Voltage, dc	V _O	-0.5	V _{DD} +0.5	V
Storage Temperature	T _S	-65	150	°C
Ambient Operating Temperature*	T _A	-40	85	°C
Junction Temperature	T _J		125	°C
Lead Temperature (soldering, 10s)			260	°C
ESD Protection, Human Body Model			2	kV

Exposure of the device under conditions beyond the limits specified by Maximum Ratings for extended periods may cause permanent damage to the device and affect product reliability. These conditions represent a stress rating only, and functional operations of the device at these or any other conditions above the operational limits noted in this specification is not implied.

* Note: Operating Temperature is guaranteed by design for all parts (COMMERCIAL and INDUSTRIAL), but tested for COMMERCIAL grade only.

2. Crystal Specifications

PARAMETERS	SYMBOL	CONDITIONS	MIN.	TYP.	MAX.	UNITS
Crystal Resonator Frequency	F _{XIN}	Parallel Fundamental Mode	20		40	MHz
Crystal Loading Rating	C _{L (xtal)}	at VCON = 0V		17.7		pF
		at VCON = 1.65V		9.5		
		at VCON = 3.3V		5.4		
Crystal Pullability	C ₀ /C _{1 (xtal)}	AT cut			250	-
Recommended ESR	R _E	AT cut			30	Ω

Note: Crystal Loading rating: The listed numbers are for the IC only. Specify the crystal for the value at VCON = 1.65V and add the PCB & package parasitic. A round number (i.e. 12pF) can be achieved by adding external capacitors. Try to add the same value to XIN and XOUT, and please note, that frequency pulling and oscillator gain may decrease.

3. Voltage Control Crystal Oscillator

PARAMETERS	SYMBOL	CONDITIONS	MIN.	TYP.	MAX.	UNITS
VCXO Stabilization Time *	T _{VCXOSTB}	From power valid			10	ms
VCXO Tuning Range		F _{XIN} = 20 – 40MHz; XTAL C ₀ /C ₁ < 250 0V ≤ VCON ≤ 3.3V		500		ppm
CLK output pullability		VCON=1.65V, ±1.65V	±200			ppm
VCXO Tuning Characteristic				150		ppm/V
Pull range linearity					10	%
VCON pin input impedance			60			kΩ
VCON modulation BW		0V ≤ VCON ≤ 3.3V, -3dB	25			kHz

Note: Parameters denoted with an asterisk (*) represent nominal characterization data and are not production tested to any specific limits.

320-640MHz Low Phase Noise VCXO
4. General Electrical Specifications

PARAMETERS	SYMBOL	CONDITIONS		MIN.	TYP.	MAX.	UNITS
Supply Current, Dynamic (with Loaded Outputs)	I _{DD}	PECL/LVDS	320MHz<F _{out} <640MHz			90/70	mA
Operating Voltage	V _{DD}			2.97		3.63	V
Output Clock Duty Cycle		@ 50% V _{DD} (CMOS)		45	50	55	%
		@ 1.25V (LVDS)		45	50	55	
		@ V _{DD} - 1.3V (PECL)		45	50	55	
Short Circuit Current					±50		mA

5. Jitter Specifications

PARAMETERS	CONDITIONS	FREQUENCY	MIN.	TYP.	MAX.	UNITS
Integrated jitter RMS	Integrated 12 kHz to 20 MHz	320.0MHz		0.4	0.5	ps
		622.08MHz		0.4	0.6	
Period jitter RMS	With capacitive decoupling between VDD and GND. Over 10,000 cycles.	320.0MHz		3	5	ps
		622.08MHz		6	8	
Period jitter Peak-to-Peak	With capacitive decoupling between VDD and GND. Over 10,000 cycles.	320.0MHz		25	30	ps
		622.08MHz		50	70	

6. Phase Noise Specifications

PARAMETERS	FREQ.	@10Hz	@100Hz	@1kHz	@10kHz	@100kHz	@1M	@10M	UNITS
Phase Noise ² relative to carrier (typical)	320.0MHz	-59	-86	-116	-129	-124	-140	-148	dBc/Hz
	622.08MHz	-48	-80	-108	-118	-114	-131	-138	

Note: Phase Noise measured at VCON = 0V

320-640MHz Low Phase Noise VCXO

8. LVDS Electrical Characteristics

PARAMETERS	SYMBOL	CONDITIONS	MIN.	TYP.	MAX.	UNITS
Output Differential Voltage	V_{OD}	$R_L = 100\ \Omega$ (see figure)	247	355	454	mV
V_{DD} Magnitude Change	ΔV_{OD}		-50		50	mV
Output High Voltage	V_{OH}			1.4	1.6	V
Output Low Voltage	V_{OL}		0.9	1.1		V
Offset Voltage	V_{OS}		1.125	1.2	1.375	V
Offset Magnitude Change	ΔV_{OS}		0	3	25	mV
Power-off Leakage	I_{OXD}	$V_{out} = V_{DD}$ or GND $V_{DD} = 0V$		± 1	± 10	μA
Output Short Circuit Current	I_{OSD}			-5.7	-8	mA

9. LVDS Switching Characteristics

PARAMETERS	SYMBOL	CONDITIONS	MIN.	TYP.	MAX.	UNITS
Differential Clock Rise Time	t_r	$R_L = 100\ \Omega$ $C_L = 10\ pF$ (see figure)	0.2	0.7	1.0	ns
Differential Clock Fall Time	t_f		0.2	0.7	1.0	ns

LVDS Levels Test Circuit

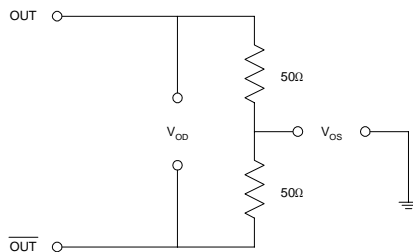

LVDS Switching Test Circuit

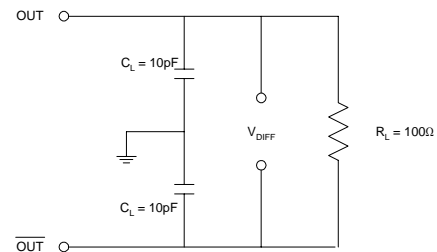

LVDS Transistion Time Waveform

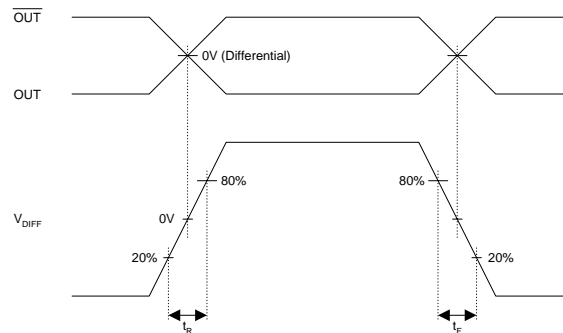

320-640MHz Low Phase Noise VCXO

10. PECL Electrical Characteristics

PARAMETERS	SYMBOL	CONDITIONS	MIN.	MAX.	UNITS
Output High Voltage	V_{OH}	$R_L = 50 \Omega$ to $(V_{DD} - 2V)$ (see figure)	$V_{DD} - 1.025$		V
Output Low Voltage	V_{OL}			$V_{DD} - 1.620$	V

11. PECL Switching Characteristics

PARAMETERS	SYMBOL	CONDITIONS	MIN.	TYP.	MAX.	UNITS
Clock Rise Time	t_r	@20/80% - PECL		0.6	1.5	ns
Clock Fall Time	t_f	@80/20% - PECL		0.5	1.5	ns

PECL Levels Test Circuit

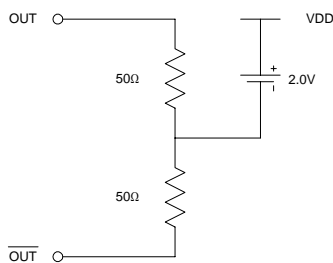

PECL Output Skew

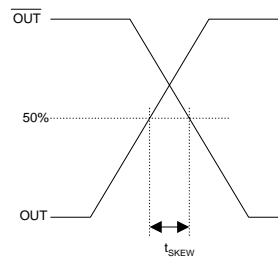

PECL Transition Time Waveform

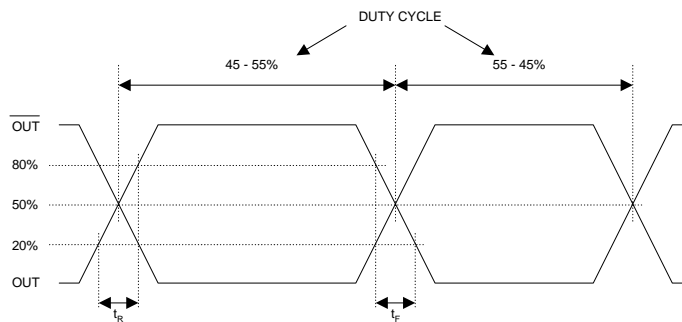

320-640MHz Low Phase Noise VCXO

LAYOUT RECOMMENDATIONS

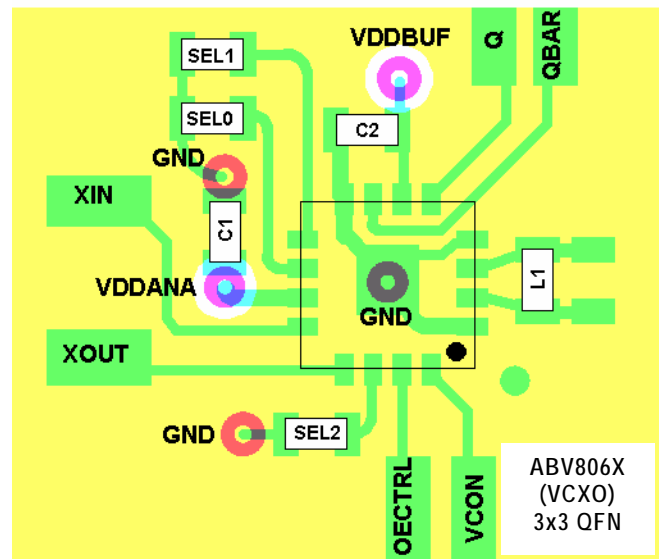
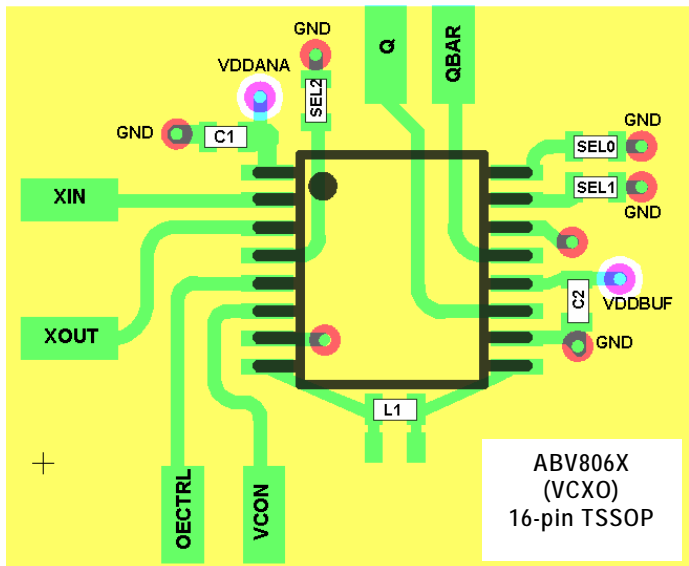

PCB LAYOUT CONSIDERATIONS FOR PERFORMANCE OPTIMIZATION

The following guidelines are to assist you with a performance optimized PCB design:

- Keep all the PCB traces to ABV80 as short as possible, as well as keeping all other traces as far away from it as possible.
- Place the crystal as close as possible to both crystal pins of the device. This will reduce the cross-talk between the crystal and the other signals.
- Separate crystal pin traces from the other signals on the PCB, but allow ample distance between the two crystal pin traces.
- Place a 0.01 μ F~0.1 μ F decoupling capacitor between VDD and GND, on the component side of the PCB, close to the VDD pin. It is not recommended to place this component on the backside of the PCB. Going through vias will reduce the signal integrity, causing additional jitter and phase noise.
- It is highly recommended to keep the VDD and GND traces as short as possible.
- Please contact Abracon for the application note on how to design outputs driving long traces or the Gerber files for the ABV80 layout.

320-640MHz Low Phase Noise VCXO

PACKAGE INFORMATION

16-PIN SSOP

16 PIN TSSOP (mm)		
Symbol	Min.	Max.
A	-	1.20
A1	0.05	0.15
B	0.19	0.30
C	0.09	0.20
D	4.90	5.10
E	4.30	4.50
H	6.40 BSC	
L	0.45	0.75
e	0.65 BSC	

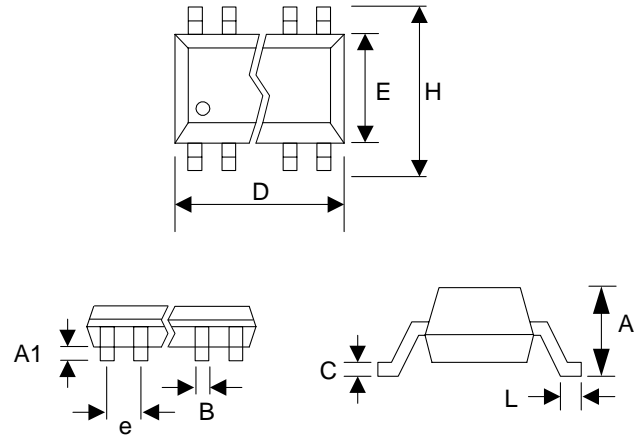

16-PIN 3x3 QFN

VARIAIONS:

SYMBOL	16 LD		
	MIN	NDM	MAX
e	0.50 BSC		
b	0.18	0.23	0.30
L	0.30	0.40	0.50
ND	4		
NE	4		

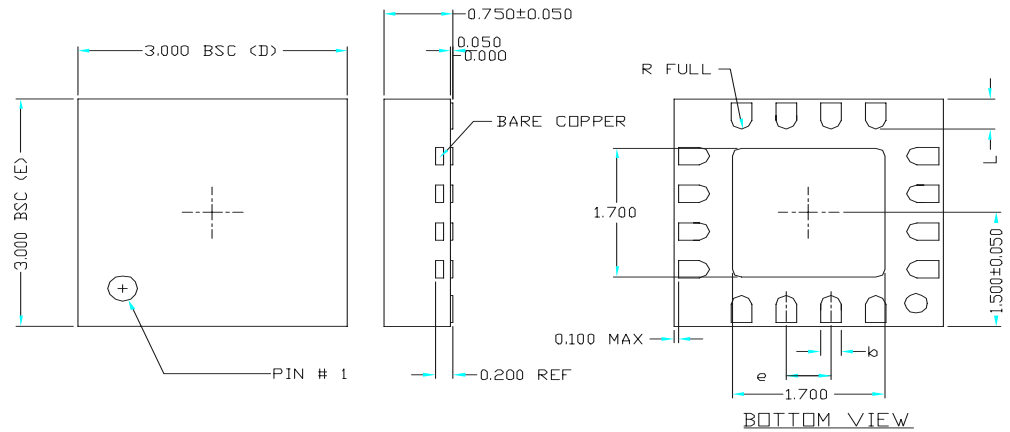

320-640MHz Low Phase Noise VCXO

ORDERING INFORMATION

For part ordering, please contact our Sales Department:
 30332 Esperanza., Rancho Santa Margarita, Ca 92688
 Ph: 949-546-8000 Fax: 949-546-8001

PART NUMBER

The order number for this device is a combination of the following:
 Device number, Package type and Operating temperature range

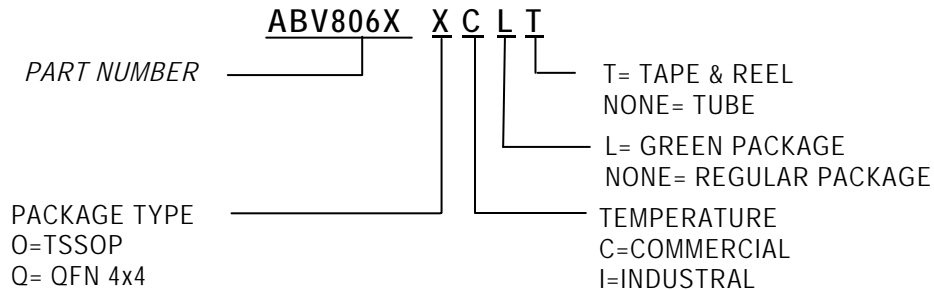

Order Number	Marking	Package Option
ABV8068OC	ABV8068OC	TSSOP - Tube
ABV8068OC-T	ABV8068OC	TSSOP - Tape & Reel
ABV8068OCL	ABV8068OCL	TSSOP - Tube (GREEN Package)
ABV8068OCL-T	ABV8068OCL	TSSOP - Tape & Reel (GREEN Package)
ABV8068QC	V8068QC	QFN - Tube
ABV8068QC-T	V8068QC	QFN - Tape & Reel
ABV8068QCL	V8068QCL	QFN - Tube (GREEN Package)
ABV8068QCL-T	V8068QCL	QFN - Tape & Reel (GREEN Package)
ABV8069OC	ABV8069OC	TSSOP - Tube
ABV8069OC-T	ABV8069OC	TSSOP - Tape & Reel
ABV8069OCL	ABV8069OCL	TSSOP - Tube (GREEN Package)
ABV8069OCL-T	ABV8069OCL	TSSOP - Tape & Reel (GREEN Package)
ABV8069QC	V8069QC	QFN - Tube
ABV8069QC-T	V8069QC	QFN - Tape & Reel
ABV8069QCL	V8069QCL	QFN - Tube (GREEN Package)
ABV8069QCL-T	V8069QCL	QFN - Tape & Reel (GREEN Package)

Abracon Corporation, reserves the right to make changes in its products or specifications, or both at any time without notice. The information furnished by Abracon is believed to be accurate and reliable. However, Abracon makes no guarantee or warranty concerning the accuracy of said information and shall not be responsible for any loss or damage of whatever nature resulting from the use of, or reliance upon this product.

LIFE SUPPORT POLICY: Abracon's products are not authorized for use as critical components in life support devices or systems without the express written approval of the President of Abracon Corporation.