

0.8 inch (20.32 mm)

SINGLE DIGIT NUMERIC LED DISPLAYS UVS-340XL SERIES

DESCRIPTION

The UVS-3401L/3403L is 0.8 inch (20.32mm) height single digit display.
Choices of five colors-high efficiency red/bright red/green/yellow/red orange.
All devices displays have gray face and white segments.
The bright red and green LED chip are made from GaP on a transparent GaP substrate.
The yellow and red orange LED chip are made from GaAsP on a transparent GaP substrate.

FEATURES

- Industuy Standard Size
- Wide Viewing angle
- Continuous uniform segments.
- Excellent characters appearance
- Low power requirement

DEVICES

PART NO.	DESCRIPTION	PACKAGE DIMENSION	INTERNAL CIRCUIT DIAGRAM
UVS-3401L	Common Anode	Fig. 1	Fig. 2
UVS-3403L	Common Cathode		

ABSOLUTE MAXIMUM RATINGS

@ T_A=25 °C

PARAMETER	HLEFF. RED	BRIGHT RED	GREEN	YELLOW	RED ORANGE	UNIT
Power Dissipation Per Segment	75	40	75	60	75	mW
Peak Forward Current Per Segment (1/10 Duty Cycle, .0.1ms pulse width)	100	60	100	80	100	mA
Continuous Forward Current Per Segment	25	15	25	20	25	mA
Derating Linear From 25°C Per Segment	0.33	0.2	0.33	0.27	0.33	mA/°C
Reverse Voltage Per Segment	5	5	5	5	5	V
Operating Temperature Range	-35°Cto+85°C					
Storage Temperature Range	-35°Cto+85°C					
Solder Temperature 1/16 inch Below Seating Plane for 3 Seconds at 260°C						



0.8 inch (20.32 mm)

SINGLE DIGIT NUMERIC LED DISPLAYS

UVS-340XL SERIES

PACKAGE DIMENSIONS

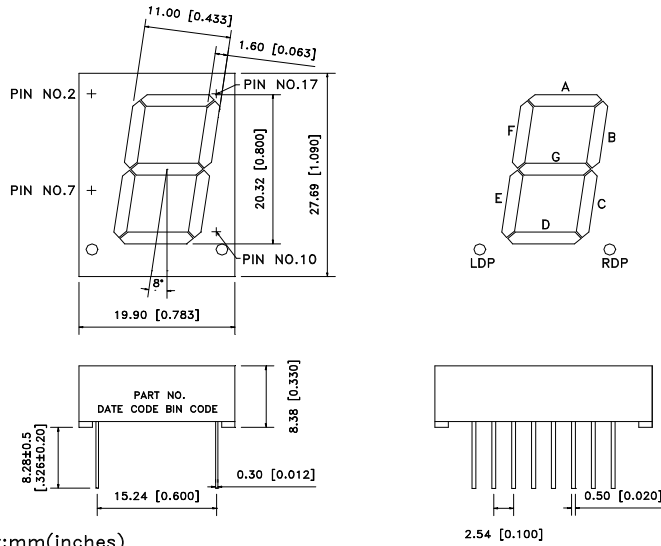

Unit:mm(inches)
Tolerance is ± 0.25mm(0.01")unless otherwise noted

Fig. 1

INTERNAL CIRCUIT DIAGRAM

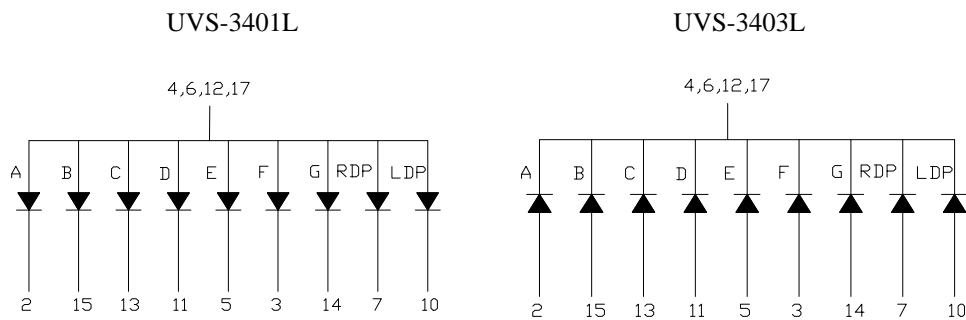

Fig. 2

0.8 inch (20.32 mm)

SINGLE DIGIT NUMERIC LED DISPLAYS

UVS-340XL SERIES

PIN CONNECTION

PIN	CONNECTION	
	UVS-3401L	UVS-3403L
1	NO PIN	NO PIN
2	CATHODE A	ANODE A
3	CATHODE F	ANODE F
4	COMMON ANODE *1	COMMON CATHODE *1
5	CATHODE E	ANODE E
6	COMMON ANODE *1	COMMON CATHODE *1
7	CATHODE L . D . P .	ANODE L . D . P .
8	NO PIN	NO PIN
9	NO PIN	NO PIN
10	CATHODE R . D . P .	ANODE R . D . P .
11	CATHODE D	ANODE D
12	COMMON ANODE *1	COMMON ANODE *1
13	CATHODE C	ANODE C
14	CATHODE G	ANODE G
15	CATHODE B	ANODE B
16	NO PIN	NO PIN
17	COMMON ANODE *1	COMMON CATHODE *1
18	NO PIN	NO PIN

NOTES: 1. PIN 4,6,12 & 17 are internally connect

ELECTRICAL/OPTICAL CHARACTERISTICS

HI.EFF. RED (UVS-3401LHR / 3403LHR)

@ T_A=25 °C

PARAMETER	SYMBOL	MIN.	TYP.	MAX.	UNIT	TEST CONDITION
Average Luminous Intensity	I _V	800	2400		μcd	I _F = 10 mA
Peak Emission Wavelength	λ _p /Hue		635/623		nm	I _F = 20 mA
Spectral Line Half-Width	Δλ		40		nm	I _F = 20 mA
Forward Voltage, Per Segment	V _F		2.0	2.6	V	I _F = 20 mA
Reverse Current, Per Segment	I _R			100	μA	V _R = 5 V
Luminous Intensity Matching Rat	I _v - m			2:1		I _F = 10 mA

BRIGHT RED (UVS-3401LP / 3403LP)

@ T_A=25 °C

PARAMETER	SYMBOL	MIN.	TYP.	MAX.	UNIT	TEST CONDITION
Average Luminous Intensity	I _V	320	950		μcd	I _F = 10 mA
Peak Emission Wavelength	λ _p /Hue		697/657		nm	I _F = 20 mA
Spectral Line Half-Width	Δλ		90		nm	I _F = 20 mA
Forward Voltage, Per Segment	V _F		2.1	2.6	V	I _F = 20 mA
Reverse Current, Per Segment	I _R			100	μA	V _R = 5 V
Luminous Intensity Matching Rat	I _v - m			2:1		I _F = 10 mA

UNI

Unity Opto Technology Co., Ltd.

11/14/2000

0.8 inch (20.32 mm)

SINGLE DIGIT NUMERIC LED DISPLAYS UVS-340XL SERIES

ELECTRICAL/OPTICAL CHARACTERISTICS

GREEN (UVS-3401LG / 3403LG)

@ T_A=25 °C

PARAMETER	SYMBOL	MIN.	TYP.	MAX.	UNIT	TEST CONDITION
Average Luminous Intensity	I _V	800	2400		mcd	I _F = 10 mA
Peak Emission Wavelength	λ _p /Hue		565/569		nm	I _F = 20 mA
Spectral Line Half-Width	Δλ		30		nm	I _F = 20 mA
Forward Voltage, Per Segment	V _F		2.1	2.6	V	I _F = 20 mA
Reverse Current, Per Segment	I _R			100	mA	V _R = 5 V
Luminous Intensity Matching Ratio	I _{V-m}			2:1		I _F = 10 mA

YELLOW (UVS-3401LY / 3403LY)

@ T_A=25 °C

PARAMETER	SYMBOL	MIN.	TYP.	MAX.	UNIT	TEST CONDITION
Average Luminous Intensity	I _V	800	2400		μcd	I _F = 10 mA
Peak Emission Wavelength	λ _p /Hue		585/588		nm	I _F = 20 mA
Spectral Line Half-Width	Δλ		35		nm	I _F = 20 mA
Forward Voltage, Per Segment	V _F		2.1	2.6	V	I _F = 20 mA
Reverse Current, Per Segment	I _R			100	μA	V _R = 5 V
Luminous Intensity Matching Ratio	I _{V-m}			2:1		I _F = 10 mA

RED ORANGE (UVS-3401LE / 3403LE)

@ T_A=25 °C

PARAMETER	SYMBOL	MIN.	TYP.	MAX.	UNIT	TEST CONDITION
Average Luminous Intensity	I _V	800	2400		μcd	I _F = 10 mA
Peak Emission Wavelength	λ _p /Hue		630/621		nm	I _F = 20 mA
Spectral Line Half-Width	Δλ		40		nm	I _F = 20 mA
Forward Voltage, Per Segment	V _F		2.0	2.6	V	I _F = 20 mA
Reverse Current, Per Segment	I _R			100	μA	V _R = 5 V
Luminous Intensity Matching Ratio	I _{V-m}			2:1		I _F = 10 mA



0.8 inch (20.32 mm)

SINGLE DIGIT NUMERIC LED DISPLAYS UVS-340XL SERIES

TYPICAL ELECTRICAL/OPTICAL CHARACTERISTIC CURVES

(Ambient Temperature =25°C Unless Otherwise Noted)

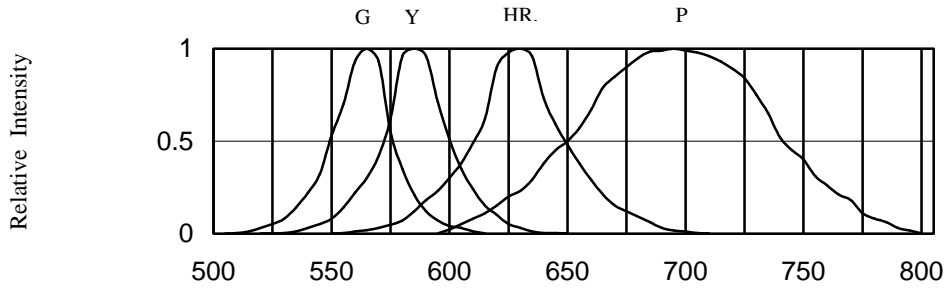

FIG.1 RELATIVE LUMINOUS INTENSITY VS. WAVELENGTH

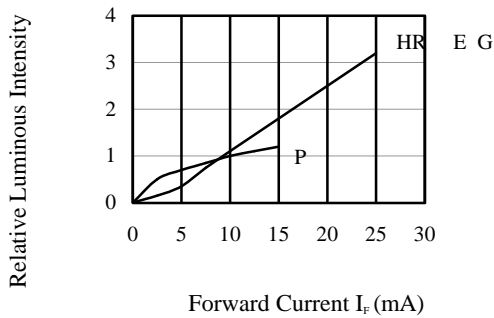

FIG.2 RELATIVE LUMINOUS INTENSITY VS. FORWARD CURRENT

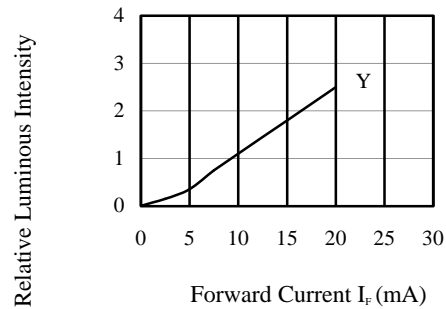

FIG.2-1 RELATIVE LUMINOUS INTENSITY VS. FORWARD CURRENT

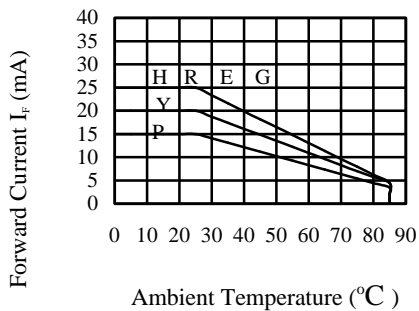

FIG.3 ALLOWABLE DC CURRENT VS. AMBIENT TEMPERATURE

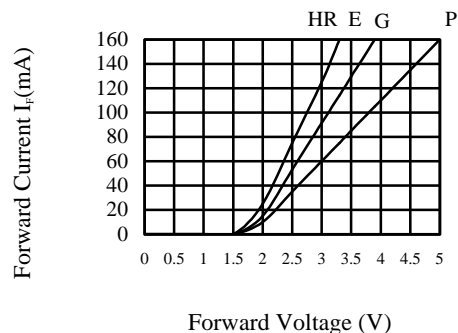

FIG.4 FORWARD CURRENT VS. FORWARD VOLTAGE