

VI TELEFILTER**Filter Specification****TFS 70AC****1/5****Measurement condition**

Ambient temperature T_A : 25 °C
 Input power level: 0 dBm
 Terminating impedances at f_C *):
 Input: 484 Ω || -22,0pF
 Output: 127 Ω || -33,4pF

Characteristics

Remark: Reference level for the relative attenuation a_{rel} of the **TFS 70AC** is the minimum of the pass band attenuation a_{min} . The minimum of the pass band attenuation a_{min} is defined as the insertion loss a_e . The centre frequency f_C is the arithmetic mean value of the upper and lower frequencies at the 3 dB filter attenuation level relative to the insertion loss a_e . The temperature coefficient of frequency TC_f is valid for both the reference frequency f_C and the frequency response of the filter in the operating temperature range.

Data		typ. value	tolerance / limit
Insertion loss (reference level)	a_e	7,5 dB	max. 9,5 dB
Centre frequency at ambient temperature	f_C	70 MHz	70,0 \pm 0,1 MHz
Pass band Amplitude ripple within PB	PB	$f_C \pm 3,6$ MHz 0,3 dB	$f_C \pm 2,8$ MHz max. 1 dB
Relative attenuation	a_{rel}		
f_C	$f_C \pm 3,1$ MHz	0,5 dB	max. 1 dB
$f_C \pm 3,1$ MHz	$f_C \pm 3,5$ MHz	2 dB	max. 3 dB
$f_C \pm 5,975$ MHz	$f_C \pm 20$ MHz	50 dB	min. 40 dB
Group delay at f_C		1,21 μ s	
Group delay ripple in PB		68 ns	max. 120 ns
Phase linearity in $f_C \pm 2,45$ MHz		4 deg p-p	max. 8 deg p-p
Operating temperature range		-	- 30 °C ... + 80 °C
Storage temperature range		-	- 40 °C ... + 85 °C
Temperature coefficient of frequency TC_f**		- 94 ppm / K	-

*) The terminating impedances depend on parasitics and q-values of matching elements and the board used, and are to be understood as reference values only. Should there be additional questions, do not hesitate to ask for an application note or contact our design team.

***) $\Delta f_C(\text{Hz}) = TC_f(\text{ppm/K}) \times (T - T_A) \times f_N(\text{MHz})$

generated:

checked / approved:

TELEFILTER GmbH
Potsdamer Straße 18
D 14 513 TELTOW / Germany
Tel: (+49) 3328 4784-0 / Fax: (+49) 3328 4784-30
E-Mail: tf@telefilter.com

VI TELEFILTER reserves the right to make changes to the product(s) and/or information contained herein without notice. No liability is assumed as a result of their use or application. No rights under any patent accompany the sale of any such product(s) or information.

Construction and pin connection

(All dimensions in mm)

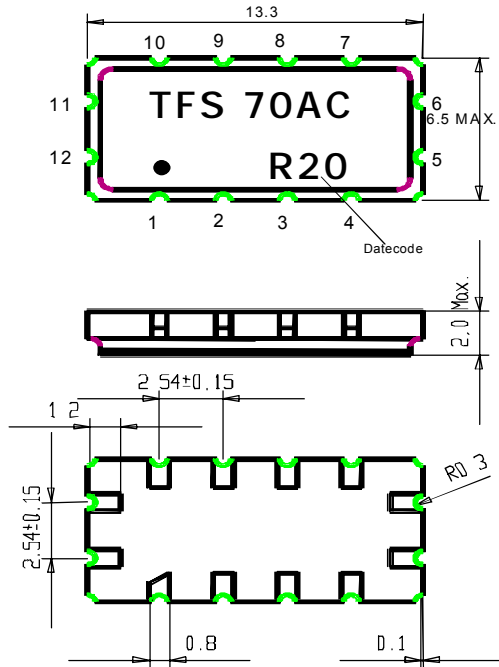

1	ground
2	ground
3	ground
4	ground
5	output
6	output rf return
7	ground
8	ground
9	ground
10	ground
11	input
12	input rf return

date code:	year + week
N	2001
P	2002
R	2003
..	

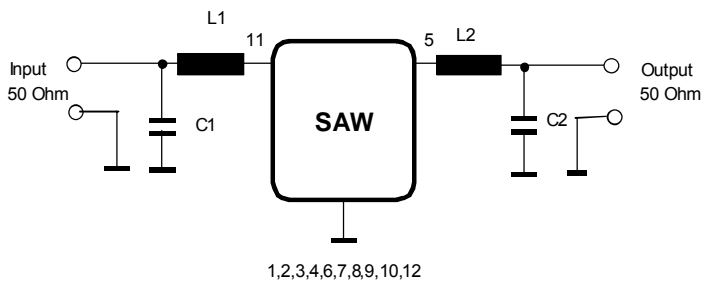
50 Ω matching network :

TELEFILTER GmbH
 Potsdamer Straße 18
 D 14 513 TELTOW / Germany
 Tel: (+49) 3328 4784-0 / Fax: (+49) 3328 4784-30
 E-Mail: tf@telefilter.com

VI TELEFILTER reserves the right to make changes to the product(s) and/or information contained herein without notice. No liability is assumed as a result of their use or application. No rights under any patent accompany the sale of any such product(s) or information.

Stability Characteristics

After the following tests the filter shall meet the whole specification:

1. Shock: 500g, 18 ms, half sine wave, 3 shocks each plane;
DIN IEC 68 T2 - 27
2. Vibration: 10 Hz to 500 Hz, 0,35 mm or 5g respectively, 1 octave per min, 10 cycles per plan, 3 plans;
DIN IEC 68 T2 - 6
3. Change of temperature: -55 °C to 125°C / 30 min. each / 10 cycles
DIN IEC 68 part 2 – 14 Test N
4. Resistance to solder heat (reflow): reflow possible: twice max.;
for temperature conditions, please refer to the attached "Air reflow temperature conditions" on page 4;

Packing

Tape & Reel: DIN IEC 286 – 3, with exception of value for N and minimum bending radius;
tape type II, embossed carrier tape with top cover tape on the upper side;

max. pieces of filters per reel:	1700
reel of empty components at start:	min 300 mm
reel of empty components at start including leader:	min 500 mm
trailer	min 300 mm

Tape (all dimensions in mm)

W : 24 ± 0,3
 P₀ : 4 ± 0,1
 D₀ : 1,5 ± 0,1
 E : 1,75 ± 0,1
 F : 11,5 ± 0,1
 G (min) : 0,60
 P₂ : 2 ± 0,1
 P₁ : 12 ± 0,1
 D₁(min) : 1,5
 A₀ : 7,1 ± 0,1
 B₀ : 13,9 ± 0,1
 CT : 21,5 ± 0,1

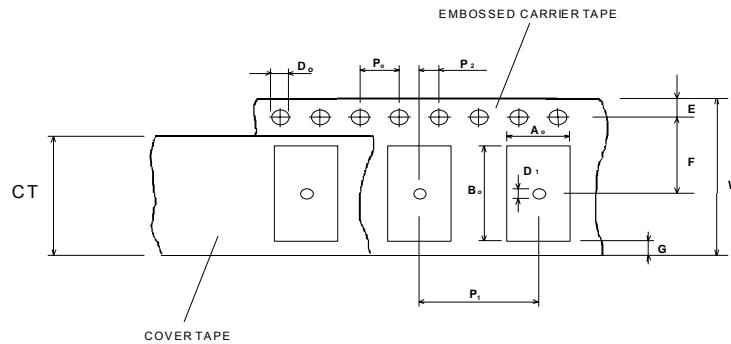

Reel (all dimensions in mm):

A : 330
 W₁ : 24,40 ± 2,0
 W₂ (max) : 30,4
 N (min) : 60
 C : 13 +0,5/-0,2

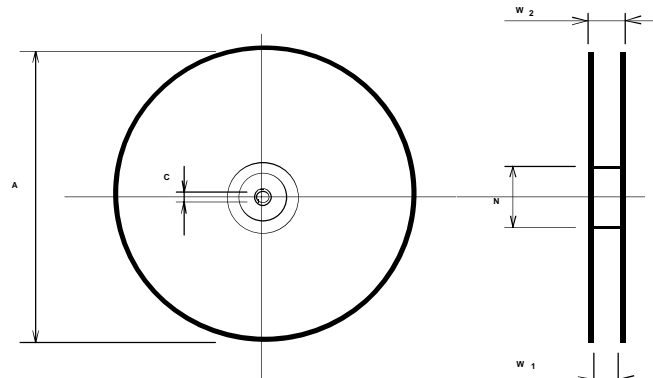

The minimum bending radius is 45 mm. The mounting surface of the filters faces the bottom side of the embossed carrier tape. Markings on the filters can be read if the upper side of the carrier tape is regarded with the sprocket holes on its right.

TELEFILTER GmbH
Potsdamer Straße 18
D 14 513 TELTOW / Germany
Tel: (+49) 3328 4784-0 / Fax: (+49) 3328 4784-30
E-Mail: tf@telefilter.com

VI TELEFILTER reserves the right to make changes to the product(s) and/or information contained herein without notice. No liability is assumed as a result of their use or application. No rights under any patent accompany the sale of any such product(s) or information.

Air reflow temperature conditions

1st and 2nd air reflow profile

Name:	pre-heating periods	main-heating periods	peak temperature
Temperature:	150 °C - 170 °C	over 200 °C	255 °C ± 5 °C
Time:	60 sec. - 90 sec.	20 sec. - 25 sec.	

Air reflow profile

Table for temperature vs. time during the air reflow process

Tolerance of temperatures: ± 5 °C

time / sec.	temperature / °C	time / sec.	temperature / °C
0	23	140	160
10	34	150	161
20	46	160	164
30	60	170	170
40	80	180	180
50	103	190	205
60	121	195	230
70	134	200	255
80	143	205	230
90	150	210	205
100	154	215	180
110	156	220	165
120	158	230	140
130	159	240	120

TELEFILTER GmbH
 Potsdamer Straße 18
 D 14 513 TELTOW / Germany
 Tel: (+49) 3328 4784-0 / Fax: (+49) 3328 4784-30
 E-Mail: tff@telefilter.com

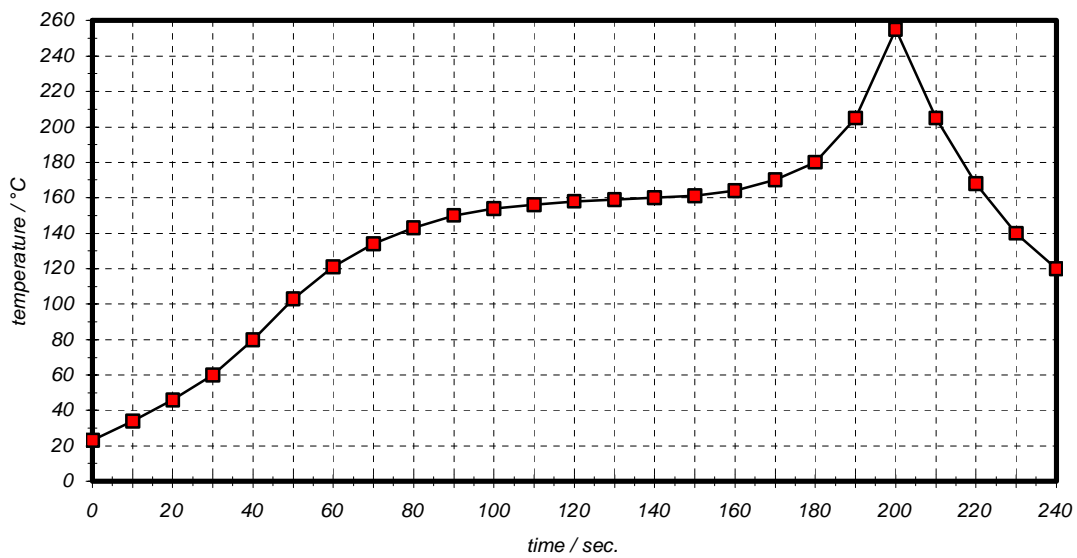
VI TELEFILTER reserves the right to make changes to the product(s) and/or information contained herein without notice. No liability is assumed as a result of their use or application. No rights under any patent accompany the sale of any such product(s) or information.

VI TELEFILTER**Filter Specification****TFS 70AC****5/5****History**

Version	Reason of Changes	Name	Date
1.0	- generate development specification	Pfeiffer	14.05.2003
1.1	- f_N changed to f_c generate development specification - remove nominal frequency f_N	Chilla	08.09.2003
1.2	- changed to filter specification - terminating impedances added - typical values added - group delay at f_N changed to 1,21 μ s typical value - matching network added	Chilla	24.11.2003

TELEFILTER GmbH
Potsdamer Straße 18
D 14 513 TELTOW / Germany
Tel: (+49) 3328 4784-0 / Fax: (+49) 3328 4784-30
E-Mail: tf@telefilter.com

VI TELEFILTER reserves the right to make changes to the product(s) and/or information contained herein without notice. No liability is assumed as a result of their use or application. No rights under any patent accompany the sale of any such product(s) or information.