

VI TELEFILTER**Filter Specification****TFS 400 D - 1/4****Application**

The filter is suitable for GSM, DCS 1800 and dual band applications. It can especially be used in the first IF in which full channel selectivity is not necessary. The filter is very compact, thus it saves cost and space on the printed circuit board.

Measurement condition

Ambient temperature: 25 °C
 Input power level: 10 dBm
 Terminating impedances
 for input: 600 Ω || 90 nH
 for output: 600 Ω || 90 nH
 coupling coil 56 nH

Construction and pin configuration

see page 2

Characteristics**Remark:**

Reference level for the relative attenuation a_{rel} of the TFD 400 D is the minimum of the pass band attenuation a_{min} . The minimum of the pass band attenuation a_{min} is defined as the insertion loss a_e . The center frequency f_0 is the arithmetic mean value of the upper and lower frequencies at the 3 dB filter attenuation level relative to the insertion loss a_e . The nominal frequency f_N is fixed on 400 MHz without tolerance. The given values for the relative attenuation a_{rel} and for the group delay ripple have to be reached at the frequencies given below also if the center frequency f_0 is shifted due to the temperature coefficient of frequency TC_f in the operating temperature range and due to a production tolerance for the center frequency f_0 .

Development Data	typ. value	tolerance/limit		
Insertion loss $a_e = a_{min}$ including losses in matching circuit (Reference level)	3,8	max.	6,0	dB
Nominal frequency f_N	-		400,000	MHz
Usable signal bandwidth	375	min.	166	kHz
passband ripple $f_N \pm 83$ kHz	0,5	max.	2,0	dB
Relative attenuation a_{rel}				
$f_N \pm 400$ kHz ... $f_N \pm 600$ kHz	23	min.	7	dB
$f_N \pm 600$ kHz ... $f_N \pm 800$ kHz	42	min.	10	dB
$f_N \pm 800$ kHz ... $f_N \pm 1,5$ MHz	55	min.	20	dB
$f_N \pm 1,5$ MHz ... $f_N \pm 100$ MHz	60	min.	35	dB
Group delay ripple GD $f_N \pm 83$ kHz	0,5	max.	1,0	μs
Operating temperature range	- 40 °C ... + 85 °C			
Temperature coefficient of frequency TC	ca. - 0,036 ppm/K ²			
Frequency inversion temperature	+ 25 °C			

Generated:

Checked / approved:

Construction, pin configuration and 50 Ω - matching network

VI TELEFILTER
 Potsdamer Straße 18
 D 14 513 TELTOW / Germany
 Tel: (+49) 3328 4784-52 / Fax: (+49) 3328 4784-30
 E-Mail: tft@telefilter.com

Vectron International, Inc.
 267 Lowell Road
 Hudson, NH 03051 / USA
 Tel: (603) 598-0070 Fax: (603) 598-0075
 E-Mail: vti@vtin.com

VI TELEFILTER

Filter Specification

TFS 400 D - 2/4

(All dimensions in mm)

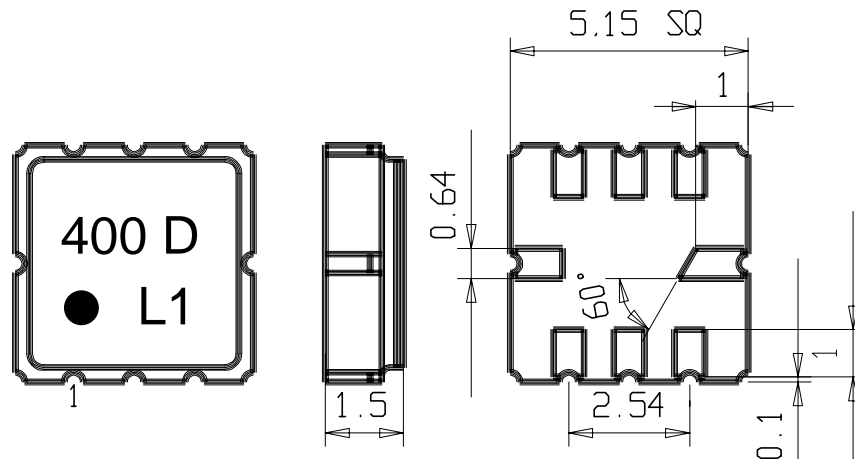

- | | | | |
|-------|----------------|-------|------------------------|
| Pin 1 | Input | Pin 5 | Output |
| Pin 2 | Ground | Pin 6 | Ground |
| Pin 3 | Ground | Pin 7 | External Coupling Coil |
| Pin 4 | Package Ground | Pin 8 | Package ground |

50 Ohm Test circuit 1

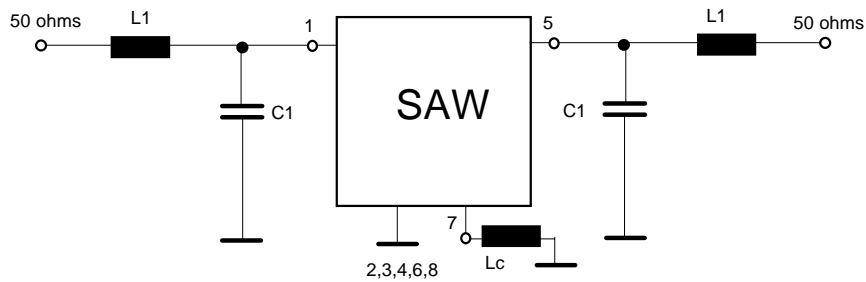

50 Ohm Test circuit 2

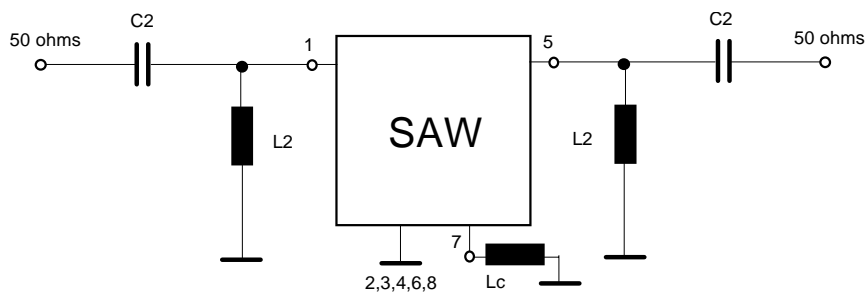

Element values depend on PCB layout. A test board and measured S-parameters will be supplied upon request.

Stability Characteristics

After the following tests the filter shall meet the whole specification:

VI TELEFILTER
 Potsdamer Straße 18
 D 14 513 TELTOW / Germany
 Tel: (+49) 3328 4784-52 / Fax: (+49) 3328 4784-30
 E-Mail: tft@telefilter.com

Vectron International, Inc.
 267 Lowell Road
 Hudson, NH 03051 / USA
 Tel: (603) 598-0070 Fax: (603) 598-0075
 E-Mail: vti@vtinh.com

VI TELEFILTER**Filter Specification****TFS 400 D - 3/4**

1. IEC 68-2-14 32 cycles Ta= -45°C Tb= +85°C t= 0,5h each
2. IEC 68-2-3 85°C 95% RH t=240h
3. IEC 68-2-6 Fc 10/500 -0,35/50 -30/3
4. IEC 68-2-29 Ea 6-10000-18/6
5. standart check at production
6. aging 125°C for 1000h
7. time leak test $<5 \cdot 10^{-8}$ atm. cc/sec.
8. 2 time reflow profil max. 260 ± 5°C for 10 s

Packing

Tape & Reel: IEC 286 - 3, with exception of value for N and minimum bending radius;
 tape type II, embossed carrier tape with top cover tape on the upper side;
 max. pieces of filters per reel: 3000

Tape (all dimensions in mm)

W	: 16 ± 0,3
Po	: 4 ± 0,1
Do	: 1,5 + 0,5
D1	: 1,5 + 0,5
E	: 1,75 ± 0,1
F	: 7,5 ± 0,1
G (min)	: 0,75
P2	: 2 ± 0,05
P1	: 8 ± 0,1
D1 (min)	: 1,5
Ao	: 5,4 ± 0,1
Bo	: 5,4 ± 0,1

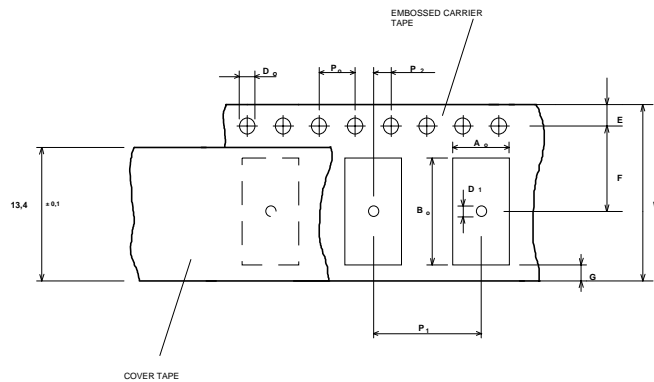
**Reel (all dimensions in mm):**

A	:	330
W1	:	16,4 + 2
W2 (max)	:	22,4
N (min)	:	>= 90
C	:	13 ± 0,25 ^A

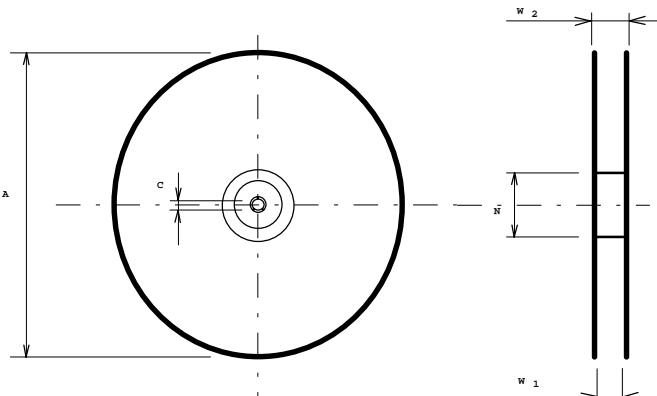

The minimum bending radius is 45 mm. The mounting surface of the filters faces the bottom side of the embossed carrier tape. The marking of the filters is able to read if the view is directed on the upper side of the carrier tape with the sprocket holes on the right side of the tape.

VI TELEFILTER

Potsdamer Straße 18
 D 14 513 TELTOW / Germany
 Tel: (+49) 3328 4784-52 / Fax: (+49) 3328 4784-30
 E-Mail: tft@telefilter.com

Vectron International, Inc.

267 Lowell Road
 Hudson, NH 03051 / USA
 Tel: (603) 598-0070 Fax: (603) 598-0075
 E-Mail: vti@vtinh.com

Air reflow temperature conditions

1st and 2nd air reflow profile

Name:	pre-heating periods	main-heating periods	peak temperature
Temperature:	150 °C - 170 °C	over 200 °C	255 °C ± 5 °C
Time:	60 sec. - 90 sec.	20 sec. - 25 sec.	

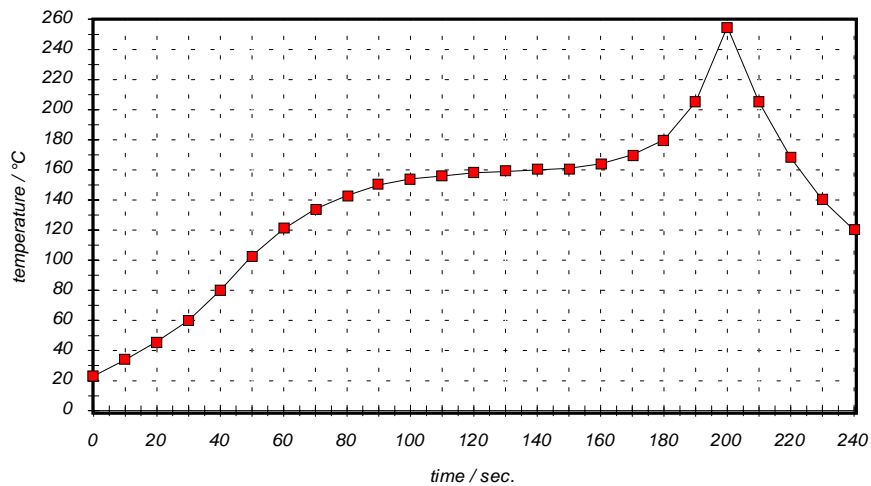
Chip-mount air reflow profile

Table for temperature vs. time during the air reflow process

Tolerance of temperatures: ± 5 °C

time / sec.	temperature / °C	time / sec.	temperature / °C
0	23	140	160
10	34	150	161
20	46	160	164
30	60	170	170
40	80	180	180
50	103	190	205
60	121	195	230
70	134	200	255
80	143	205	230
90	150	210	205
100	154	215	180
110	156	220	165
120	158	230	140
130	159	240	120