

VI TELEFILTER**Filter specification****TFS 175 D****1/5****Measurement condition**

Ambient temperature: 23 °C
 Input power level: 0 dBm
 Terminating impedances at f_c *: input: 570 Ω // -5,4 pF
 output: 500 Ω // -6,4 pF

Characteristics**Remark:**

Reference level for the relative attenuation a_{rel} of the TFS 175 D is the minimum of the pass band attenuation a_{min} . The minimum of the pass band attenuation a_{min} is defined as the insertion loss a_e . The centre frequency f_c is the arithmetic mean value of the upper and lower frequencies at the 3 dB filter attenuation level relative to the insertion loss a_e . The nominal frequency f_N is fixed at 175,400 MHz without tolerance. The given values for the relative attenuation a_{rel} and for the group delay ripple have to be reached at the frequencies given below even if the centre frequency f_c is shifted due to the temperature coefficient of frequency TC_f in the operating temperature range and due to a production tolerance for the centre frequency f_c .

D a t a		typ. Value		Limit	
Insertion loss (Reference level)	a_e	6	dB	max.	8 dB
Nominal frequency	f_N	-			175,4 MHz
Centre frequency	f_c	175,4	MHz		
1 dB Passband	PB	770	kHz	$f_N \pm$	250 kHz
Amplitude ripple in PB	p-p	-		max.	1 dB
Relative Attenuation	a_{rel}				
$f_N \pm 5,0$ MHz	$f_N \pm 10,0$ MHz	50	dB	min.	30 dB
$f_N + 10,0$ MHz	$f_N + 12,0$ MHz	53	dB	min.	50 dB
$f_N + 12,0$ MHz	$f_N + 75,0$ MHz	60	dB	min.	55 dB
$f_N + 75,0$ MHz	$f_N + 1,0$ GHz	60	dB	min.	50 dB
$f_N - 75,0$ MHz	$f_N - 10,0$ MHz	65	dB	min.	55 dB
$f_N - 174,4$ MHz	$f_N - 75,0$ MHz	70	dB	min.	50 dB
Group delay variation in PB		60	ns	max.	200 ns
Time domain response **					
	5 μ s	-62	dBc	min	-30 dBc
	10 μ s	-85	dBc	min	-50 dBc
	15 μ s	-85	dBc	min	-70 dBc
	20 μ s	-85	dBc	min	-80 dBc
	40 μ s	-95	dBc	min	-90 dBc
Input Power Level		-		max.	20 dBm ^{***})
Voltage between any two terminals		-		max	30 V
Temperature coefficient of frequency TC_f		- 0,036	ppm/K ²		
Operating temperature range		-		-10 °C .. +	85 °C
Storage temperature range		-		- 40 °C.. +	125 °C
Out of band intermodulation results input signals at 176 and 176,6 MHz at 4 dBm				max.	-56 dBm

*) The terminating impedances depend on parasitics and q-values of matching elements and the board used, and are to be understood as reference values only. Should there be additional questions do not hesitate to ask for an application note or contact our design team.

**) Values are relative to the centre of the main response lobe

***) This power level is only allowed for short term operation, the max. input power for continuous operation is only max. 15 dBm

generated: _____

checked / approved: _____

VI TELEFILTER
 Potsdamer Straße 18
 D 14 513 TELTOW / Germany
 Tel: (+49) 3328 4784-0 / Fax: (+49) 3328 4784-30
 E-Mail: tft@telefilter.com

Vectron International, Inc.
 267 Lowell Road
 Hudson, NH 03051 / USA
 Tel: (603) 598-0070 Fax: (603) 598-0075
 E-Mail: vti@vtinh.com

VI TELEFILTER reserves the right to make changes to the product(s) and/or information contained herein without notice. No liability is assumed as a result of their use or application. No rights under any patent accompany the sale of any such product(s) or information.

Construction and Pin Connection

(All dimensions in mm)

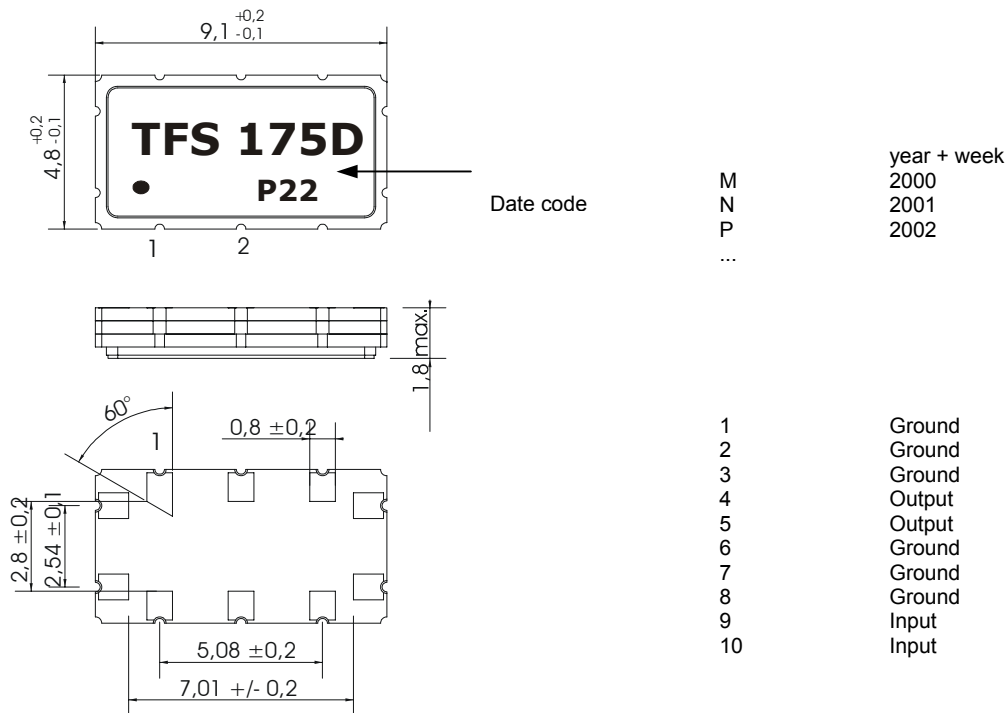
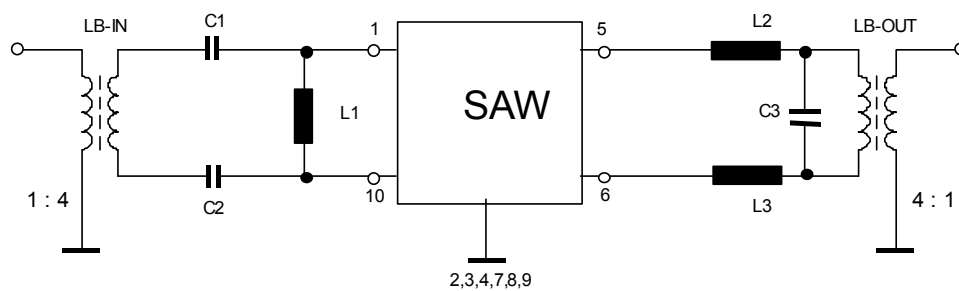
**200 Ω matching circuit:**

Stability Characteristics

After the following tests the filter shall meet the whole specification:

1. Shock: 500g, 18 ms, half sine wave, 3 shocks each plane;
DIN IEC 68 T2 - 27
2. Vibration: 10 Hz to 500 Hz, 0,35 mm or 5g respectively, 1 octave per min, 10 cycles per plan, 3 plans;
DIN IEC 68 T2 - 6
3. Change of temperature: -55 °C to 125°C / 30 min. each / 10 cycles
DIN IEC 68 part 2 – 14 Test N
4. Resistance to solder heat (reflow): reflow possible: twice max.;
for temperature conditions, please refer to the attached "Air reflow temperature conditions" on page 4;

Packing

Tape & Reel: DIN IEC 286 – 3, with exception of value for N and minimum bending radius;
tape type II, embossed carrier tape with top cover tape on the upper side;

max. pieces of filters per reel:
reel of empty components at start:
reel of empty components at start including leader:
trailer

3000
min 300 mm
min 500 mm

min 300

mm

Tape (all dimensions in mm)

W	: 16 ± 0,3
Po	: 4 ± 0,1
Do	: 1,5 + 0,1
E	: 1,75 ± 0,1
F	: 7,5 ± 0,1
G (min)	: 0,60
P2	: 2 ± 0,1
P1	: 8 ± 0,1
D1(min)	: 1,5
Ao	: 5,30 ± 0,1
Bo	: 9,70 ± 0,1
CT	: 13,5 ± 0,1

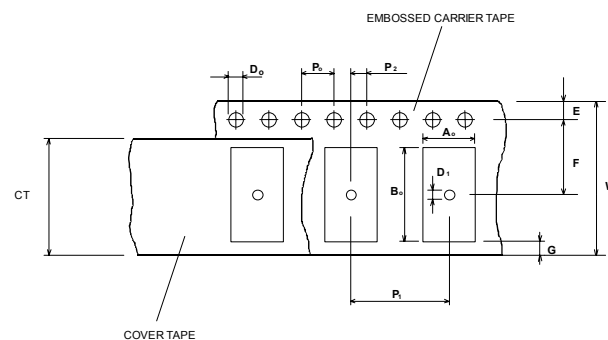
**Reel (all dimensions in mm):**

A	: 330
W1	: 16,40 +2,0
W2 (max)	: 22,4
N (min)	: 50
C	: 13,0 ± 0,5/-0,2

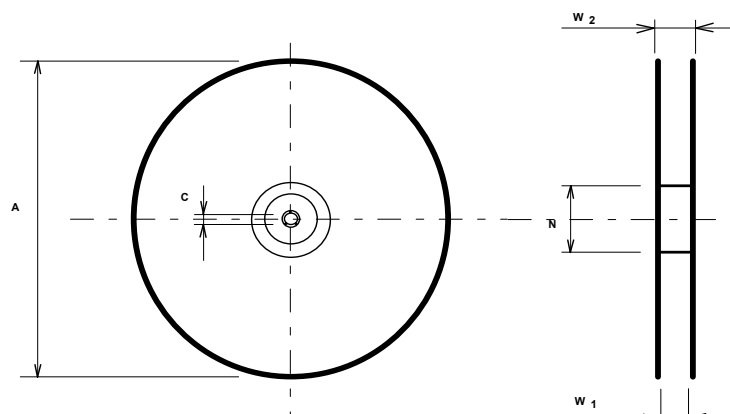

The minimum bending radius is 45 mm. The mounting surface of the filters faces the bottom side of the embossed carrier tape. Markings on the filters can be read if the upper side of the carrier tape is regarded with the sprocket holes on its right.

VI TELEFILTER

Potsdamer Straße 18
D 14 513 TELTOW / Germany
Tel: (+49) 3328 4784-0 / Fax: (+49) 3328 4784-30
E-Mail: tft@telefilter.com

Vectron International, Inc.
267 Lowell Road
Hudson, NH 03051 / USA
Tel: (603) 598-0070 Fax: (603) 598-0075
E-Mail: vti@vtinh.com

VI TELEFILTER reserves the right to make changes to the product(s) and/or information contained herein without notice. No liability is assumed as a result of their use or application. No rights under any patent accompany the sale of any such product(s) or information.

Air reflow temperature conditions

1st and 2nd air reflow profile

Name:	pre-heating periods	main-heating periods	peak temperature
Temperature:	150 °C - 170 °C	over 200 °C	255 °C ± 5 °C
Time:	60 sec. - 90 sec.	20 sec. - 25 sec.	

Chip-mount air reflow profile

Table for temperature vs. time during the air reflow process

Tolerance of temperatures: ± 5 °C

time / sec.	temperature / °C	time / sec.	temperature / °C
0	23	140	160
10	34	150	161
20	46	160	164
30	60	170	170
40	80	180	180
50	103	190	205
60	121	195	230
70	134	200	255
80	143	205	230
90	150	210	205
100	154	215	180
110	156	220	165
120	158	230	140
130	159	240	120

VI TELEFILTER**Filter specification****TFS 175 D****5/5****History**

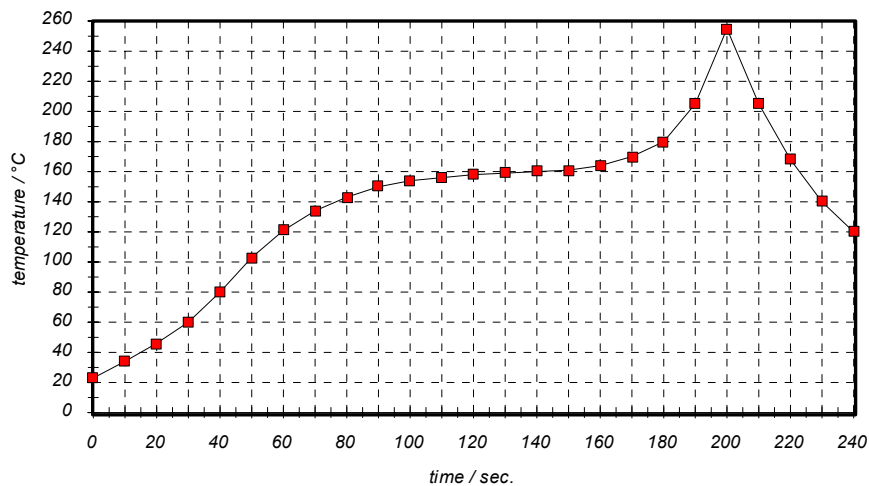
Version	Reason of Changes	Name	Date
1.0	Generation of "Development specification" according to customer requirements	Steiner	15.08.2001
1.1	- change of package - max. insertion loss : 8.5 dB	Pfeiffer	30.08.2001
1.2	- terminating impedance added - typical values added - matching configuration added	Pfeiffer	14.01.2002
1.3	- change of package - changing relative attenuation - terminating impedance changed - intermodulation added	Pfeiffer	10.04.2002
1.4	- decreasing insertion loss - extending storage temperature range	Pfeiffer	29.05.2002

VI TELEFILTER
Potsdamer Straße 18
D 14 513 TELTOW / Germany
Tel: (+49) 3328 4784-0 / Fax: (+49) 3328 4784-30
E-Mail: tft@telefilter.com

Vectron International, Inc.
267 Lowell Road
Hudson, NH 03051 / USA
Tel: (603) 598-0070 Fax: (603) 598-0075
E-Mail: vti@vtinh.com

VI TELEFILTER reserves the right to make changes to the product(s) and/or information contained herein without notice. No liability is assumed as a result of their use or application. No rights under any patent accompany the sale of any such product(s) or information.