

VI TELEFILTER	Filter specification	TFS 111B	1/5
----------------------	-----------------------------	-----------------	------------

Measurement condition

Ambient temperature: 23°C
 Input power level: 0dBm
 Terminating impedances *)
 for input: 3,2 kΩ ||- 5,6pF
 for output: 3,1 kΩ || -6.2pF

Characteristics

Remark:

The reference level for the relative attenuation a_{rel} of TFS 111B is the minimum of the pass band attenuation a_{min} . This value is defined as the insertion loss a_e . The centre frequency f_c is the arithmetic mean value of the upper and lower frequencies at the 20,0 dB filter attenuation level relative to the insertion loss a_e .

D a t a	typ. value	tolerance / limit
Insertion loss (reference level) $a_e = a_{min}$	7 dB	11 dB
Centre frequency f_c (30 dB-BW)	111 MHz	± 60 kHz
Relative attenuation a_{rel} $f_c - 500$ kHz ... $f_c + 500$ kHz	1 dB	max. 2 dB
$f_c \pm 1$ MHz ... $f_c \pm 2$ MHz	22 dB	min. 20 dB
$f_c \pm 2$ MHz ... $f_c \pm 3$ MHz	33 dB	min. 30 dB
$f_c \pm 3$ MHz ... $f_c \pm 10$ MHz	45 dB	min. 40 dB
**)		
Group delay GD Ripple $f_c \pm 500$ kHz	300 ns	max 500 ns
Temperature coefficient TC 2nd order **)	- 0,032 ppm/K ²	-
Frequency inversion temperature T_o	25 °C	
Operating temperature range		- 10 °C ... + 60 °C
Storage temperature range		- 40 °C ... + 85 °C
Input power level	-	max. + 10 dBm

*) The terminating impedances depend on parasitics and q-values of matching elements and the board used, and are to be understood as reference values only. Should there be additional questions, do not hesitate to ask for an application note or contact our design team.

**) - Δf (Hz) = TC (ppm/K²) x (T - T_o)² x F_{T_o} (MHz)

Generated: _____

Checked / approved: _____

VI TELEFILTER
 Potsdamer Straße 18
 D 14 513 TELTOW / Germany
 Tel: (+49) 3328 4784-52 / Fax: (+49) 3328 4784-30
 E-Mail: tft@telefilter.com

Vectron International, Inc.
 267 Lowell Road
 Hudson, NH 03051 / USA
 Tel: (603) 598-0070 Fax: (603) 598-0075
 E-Mail: vti@vtinh.com

VI TELEFILTER reserves the right to make changes to the product(s) and/or information contained herein without notice. No liability is assumed as a result of their use or application. No rights under any patent accompany the sale of any such product(s) or information.

Construction and pin connection

(All dimensions in mm)

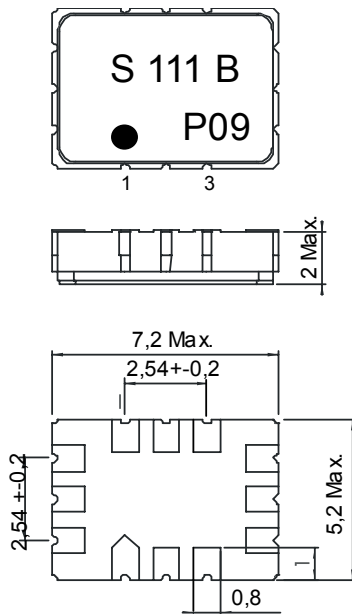

1	Ground
2	Ground
3	Output RF Return
4	Output
5	Ground
6	Ground
7	Ground
8	Ground
9	Input RF Return
10	Input
11	Ground
12	Ground

Datecode:	Year+week
M	2000
N	2001
P	2002
...	

50 Ω test circuit

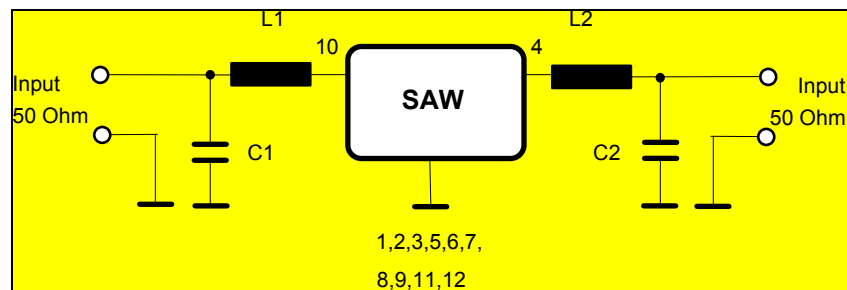

Stability Characteristics:

After the following tests the filter shall meet the whole specification:

- 1. Shock: 500g, 18 ms, half sine wave, 3 shocks each plane;
DIN IEC 68 T2 - 27
- 2. Vibration: 10 Hz to 500 Hz, 0,35 mm or 5g respectively, 1 octave per min, 10 cycles per plan, 3 plans;
DIN IEC 68 T2 - 6
- temperature: -55 °C to 125°C / 30 min each. / 10 cycles
DIN IEC 68 part 2 – 14 Test N
- 4. Resistance to solder heat (reflow): max. 2 times reflow process;
for temperature conditions refer to the attached "Air reflow temperature conditions" on page 4;

Packing:

Tape & Reel: IEC 286 - 3, with exception of value for N and minimum bending radius;
tape type II, embossed carrier tape with top cover tape on the upper side;
max. pieces of filters per reel: 3000
Reel of empty components at start: min 300 mm
Reel of empty components at start including leader: min 500 mm
Trailer min 300 mm

Tape (all dimensions in mm)

- W : 16 ± 0,3
- Po : 4 ± 0,1
- Do : 1,5 + 0,1
- E : 1,75 ± 0,1
- F : 7,5 ± 0,1
- G (min): 0,6
- P2 : 2 ± 0,1
- P1 : 8 ± 0,1
- D1(min): 1,5
- Ao : 5,5 ± 0,1
- Bo : 7,5 ± 0,1
- Ct : 13,5+/-0,1

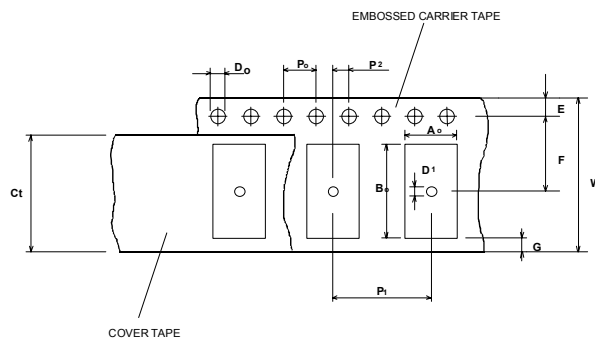

Reel (all dimensions in mm):

- A : 330
- W1 : 16,4 +2
- W2 (max): 22,4
- N (min) : 50
- C : 13 + 0,5
- 0,2

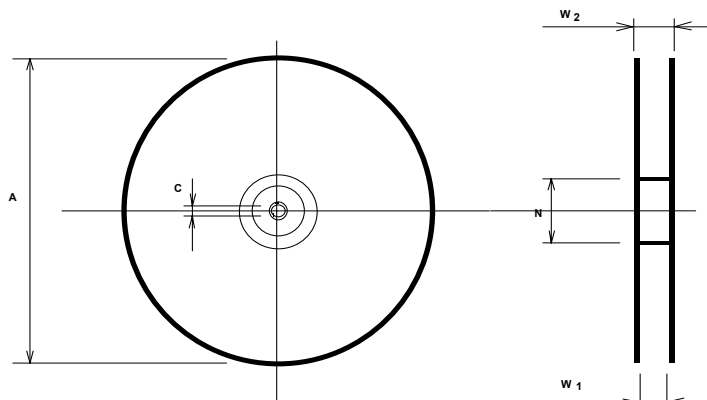

The minimum bending radius is 45 mm. The mounting surface of the filters faces the bottom side of the embossed carrier tape. Markings on the filters can be read if the upper side of the carrier tape is regarded with the sprocket holes on its right.

VI TELEFILTER
Potsdamer Straße 18
D 14 513 TELTOW / Germany
Tel: (+49) 3328 4784-52 / Fax: (+49) 3328 4784-30
E-Mail: tft@telefilter.com

Vectron International, Inc.
267 Lowell Road
Hudson, NH 03051 / USA
Tel: (603) 598-0070 Fax: (603) 598-0075
E-Mail: vti@vtinh.com

VI TELEFILTER reserves the right to make changes to the product(s) and/or information contained herein without notice. No liability is assumed as a result of their use or application. No rights under any patent accompany the sale of any such product(s) or information.

Air reflow temperature conditions

1st and 2nd air reflow profile

Name:	pre-heating periods	main-heating periods	peak temperature
Temperature:	150 °C - 170 °C	over 200 °C	255 °C ± 5 °C
Time:	60 sec. - 90 sec.	20 sec. - 25 sec.	

Air reflow profile

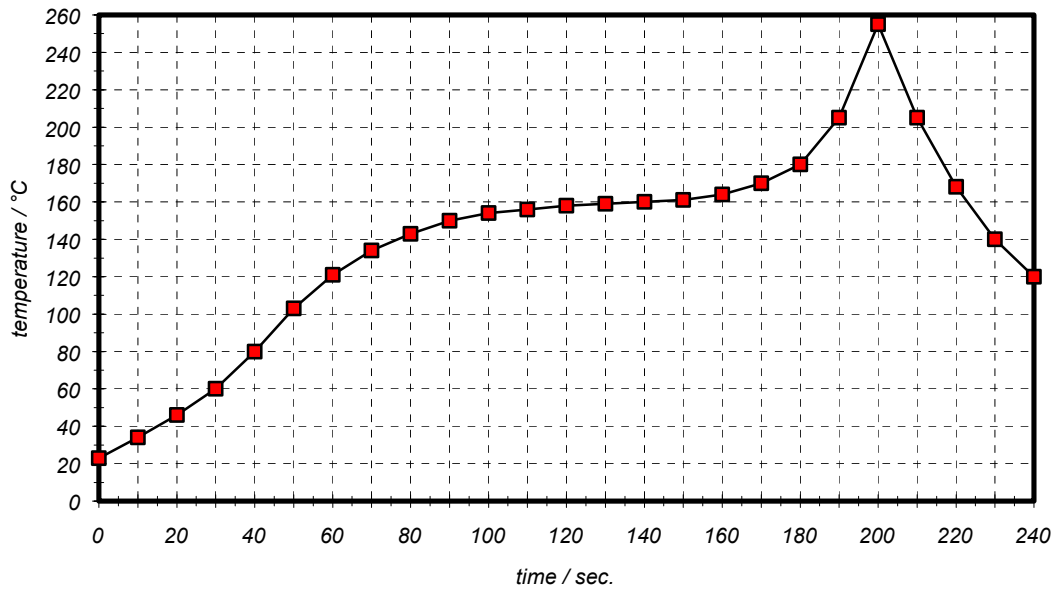

Table for temperature vs. time during the air reflow process

Tolerance of temperatures: ± 5 °C

time / sec.	temperature / °C	time / sec.	temperature / °C
0	23	140	160
10	34	150	161
20	46	160	164
30	60	170	170
40	80	180	180
50	103	190	205
60	121	195	230
70	134	200	255
80	143	205	230
90	150	210	205
100	154	215	180
110	156	220	165
120	158	230	140
130	159	240	120

VI TELEFILTER	Filter specification	TFS 111B	5/5
----------------------	-----------------------------	-----------------	------------

History

Version	Reason of Changes	Name	Date
Development specification			
1.1.	- passband ripple: 3dB → 1.5 dB - new datecode introduced and explained	Steiner	08.05.2000
1.2.	- complete specification - passband ripple, group delay ripple, attenuation at $f_c \pm 1\text{MHz}$ changed according to agreements with customer	Steiner	28.07.2000
Filter specification			
2.0	- typical values and terminating impedance added	Steiner	26.02.2002

VI TELEFILTER
Potsdamer Straße 18
D 14 513 TELTOW / Germany
Tel: (+49) 3328 4784-52 / Fax: (+49) 3328 4784-30
E-Mail: tft@telefilter.com

Vectron International, Inc.
267 Lowell Road
Hudson, NH 03051 / USA
Tel: (603) 598-0070 Fax: (603) 598-0075
E-Mail: vti@vtinh.com

VI TELEFILTER reserves the right to make changes to the product(s) and/or information contained herein without notice. No liability is assumed as a result of their use or application. No rights under any patent accompany the sale of any such product(s) or information.