

Typical Applications

- TDMA/CDMA/FM PCS Tx Amplifier
- Low Noise Transmit Driver Amplifier
- 2.4GHz WLAN Systems
- GSM1800 Driver Amplifier
- General Purpose Amplification
- Commercial and Consumer Systems

Product Description

The RF2367 is a low noise CDMA/TDMA/GSM PA driver amplifier with a very high dynamic range designed for transmit digital PCS applications with frequency ranges between 1700MHz and 2000MHz. The device functions as an outstanding PA driver amplifier in the transmit chain of digital subscriber units where low transmit noise power is a concern. The IC includes a power down feature that can be used to completely turn off the device. The RF2367 is featured in a standard SOT23-6 plastic package.

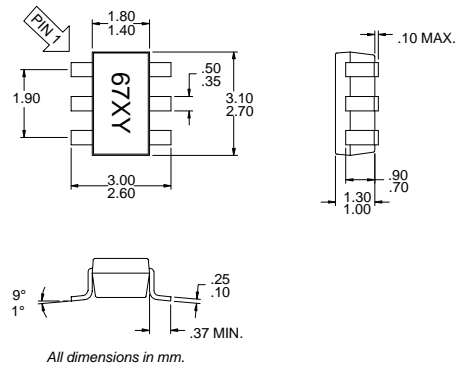

**4**  
GENERAL PURPOSE  
AMPLIFIERS

Optimum Technology Matching® Applied

- |                                     |  |                                      |
|-------------------------------------|--|--------------------------------------|
| <input type="checkbox"/> Si BJT     | <input checked="" type="checkbox"/> GaAs HBT | <input type="checkbox"/> GaAs MESFET |
| <input type="checkbox"/> Si Bi-CMOS | <input type="checkbox"/> SiGe HBT            | <input type="checkbox"/> Si CMOS     |

Package Style: SOT23-6

- Features**
- Low Noise and High Intercept Point
  - Adjustable Bias Current
  - Power Down Control
  - Single 2.5V to 6.0V Power Supply
  - 150MHz to 2500MHz Operation
  - Extremely Small SOT23-6 Package

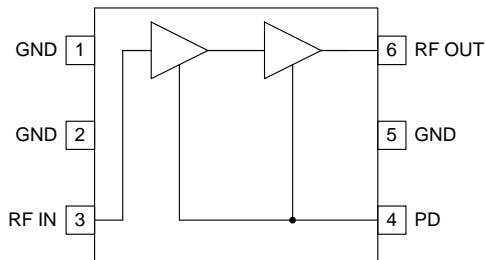

Functional Block Diagram

**Ordering Information**

RF2367	PCS CDMA/TDMA/GSM1800 3V PA Driver Amplifier
RF2367 PCBA	Fully Assembled Evaluation Board

RF Micro Devices, Inc.  
7625 Thorndike Road  
Greensboro, NC 27409, USA

Tel (336) 664 1233  
Fax (336) 664 0454  
<http://www.rfmd.com>

### Absolute Maximum Ratings

Parameter	Rating	Unit
Supply Voltage	-0.5 to +8.0	V <sub>DC</sub>
Input RF Level	+10	dBm
Storage Temperature	-40 to +150	°C



**Caution!** ESD sensitive device.

RF Micro Devices believes the furnished information is correct and accurate at the time of this printing. However, RF Micro Devices reserves the right to make changes to its products without notice. RF Micro Devices does not assume responsibility for the use of the described product(s).

Parameter	Specification			Unit	Condition
	Min.	Typ.	Max.		
<b>Operating Range</b>					
Overall Frequency Range		150 to 2500		MHz	
Supply Voltage (V <sub>CC</sub> )	2.5		6.0	V	
Power Down Voltage (V <sub>PD</sub> )	2.7		2.9	V	For normal operation
			0.9	V	For power down operation
Total Current Consumption	24	37	45	mA	V <sub>CC</sub> =3.0V, V <sub>PD</sub> =2.8V
			10	µA	V <sub>CC</sub> =3.0V, V <sub>PD</sub> <0.9V
Operating Ambient Temperature	-40		+85	°C	
Input Impedance		50		Ω	
Output Impedance		50		Ω	
<b>1880MHz Performance</b>					
Gain	20	21.5	23	dB	All parameters measured from evaluation board with T = 25 °C, RF = 1880MHz, V <sub>CC</sub> =3.0V, V <sub>PD</sub> =2.8V
Output IP3	+20	+24		dBm	
Noise Figure		2.2	2.5	dB	
Reverse Isolation	32	34		dB	
Input VSWR		1.9:1	2:1		
Output VSWR		1.5:1	2:1		Using External LC network used on Evaluation Board
Output P <sub>1dB</sub>	+13	+14	+15	dBm	

Pin	Function	Description	Interface Schematic
1	GND	Ground connection. Keep traces physically short and connect immediately to ground plane for best performance.	
2	GND	Same as pin 1.	
3	RF IN	RF input pin. This pin is DC coupled and internally matched to a <2:1 VSWR at 1880MHz.	
4	PD	Power Down for the IC. $V_{PD} = 2.8V \pm 0.1V$ turns on the Part. $V_{PD} < 0.9V$ turns off the Part. Lower threshold for device operation is approximately 1.2V. External RF bypassing is required. The trace length between the pin and the bypass capacitors should be minimized. The ground side of the bypass capacitors should connect immediately to ground plane. Nominal current for this pin for $V_{PD} = 2.8V$ is 8mA typical.	See pin 3.
5	GND	Same as pin 1.	
6	RF OUT	Amplifier Output pin. This pin is an open-collector output. It must be biased to either $V_{CC}$ or pin 4 through a choke or matching inductor. This pin is typically externally matched to $50\Omega$ with a shunt bias/matching inductor and series blocking/matching capacitor. Refer to application/evaluation board schematics.	

## Application Schematic: ~1880 MHz Operation

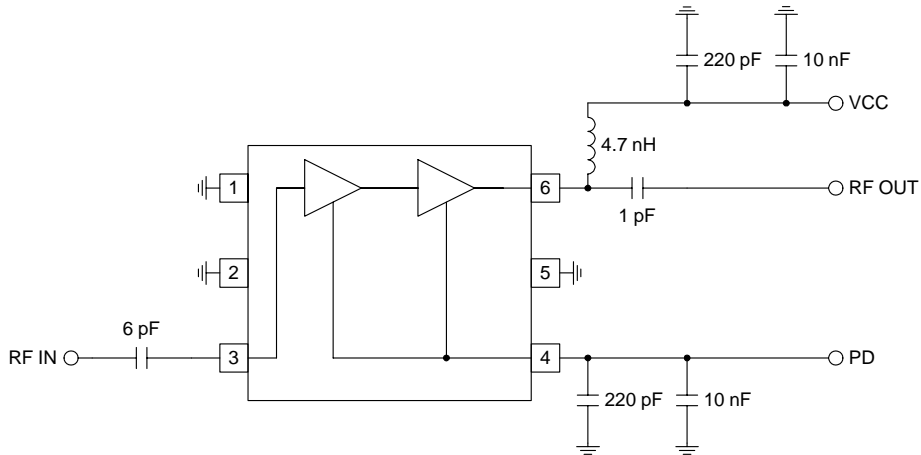

## Evaluation Board Schematic

(Download [Bill of Materials](http://www.rfmd.com) from [www.rfmd.com](http://www.rfmd.com).)

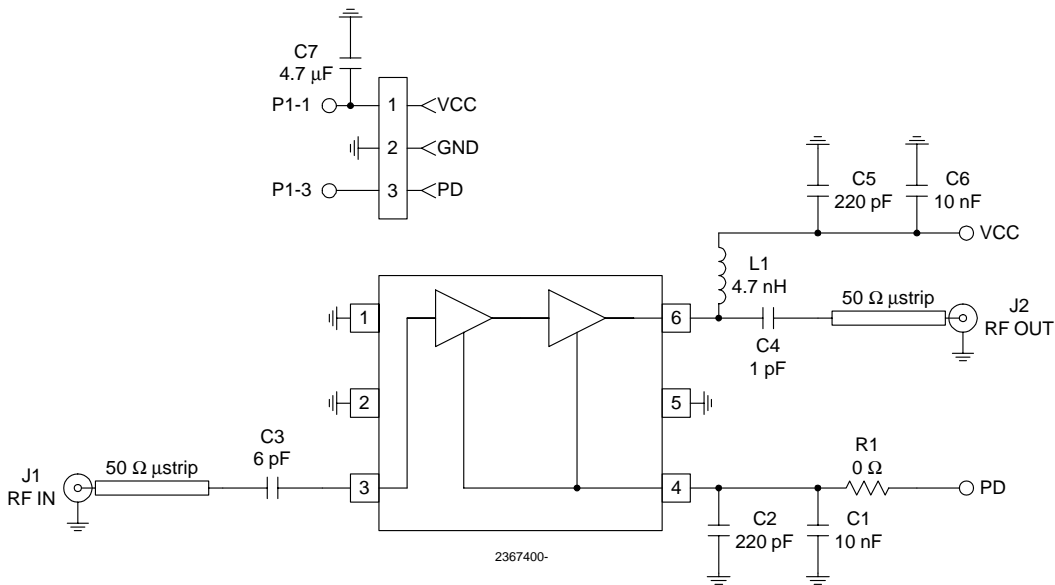

Evaluation Board Layout  
Board Size 0.948" x 1.063"  
Board Thickness 0.031", Board Material FR-4

