

**Product Features:**

- PI74FCT280T is pin compatible with bipolar FAST™ Series at a higher speed and lower power consumption
- TTL input and output levels
- Extremely low static power
- Hysteresis on all inputs
- Industrial operating temperature range: -40°C to +85°C
- Packages available:
  - 14-pin 150mil wide SOIC (W)
  - 16-pin 150mil wide QSOP (Q)

**Product Description:**

Pericom Semiconductor's PI74FCT series of logic circuits are produced in the Company's advanced 0.8 micron CMOS technology, achieving industry leading speed grades.

The PI74FCT280T is a high-speed CMOS TTL-compatible 9-bit parity generator-checkers. Both odd and even parity outputs are available for generating or checking odd or even parity.

**Logic Block Diagram**

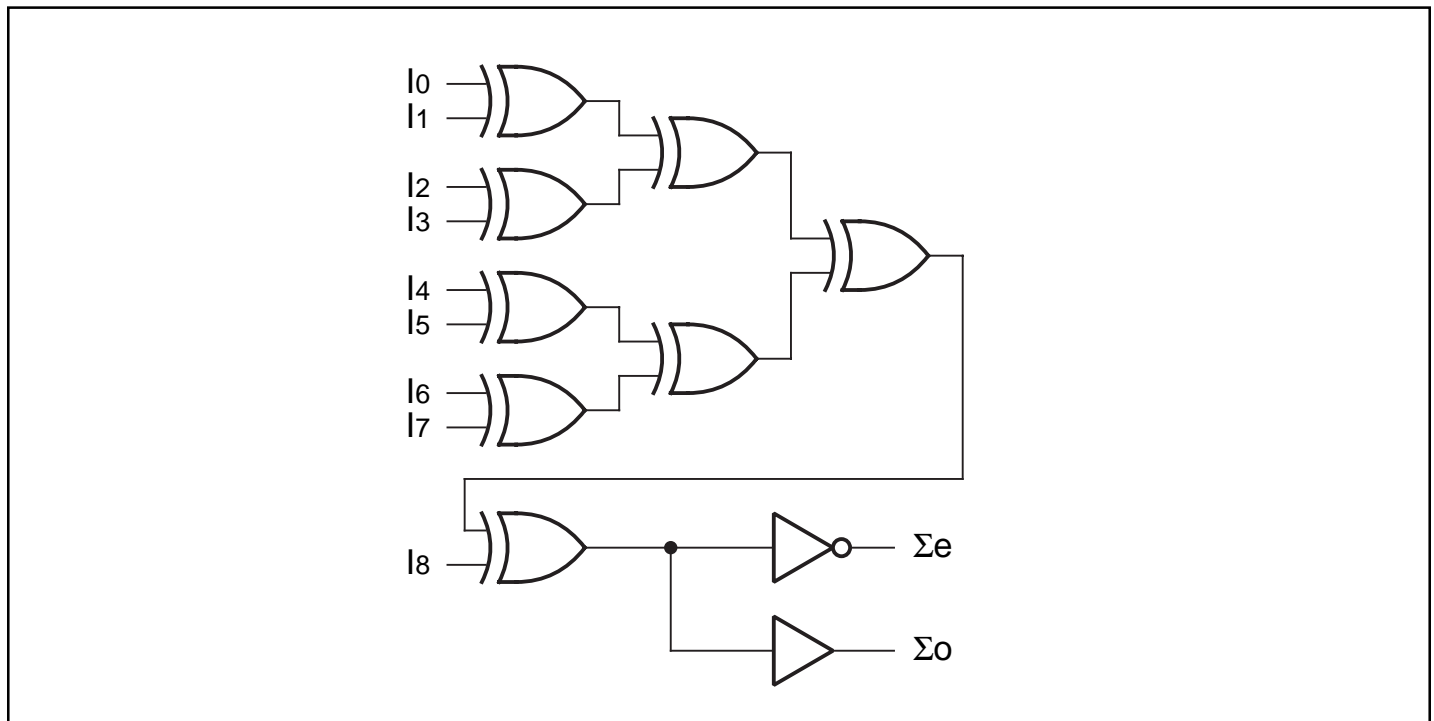

**PI74FCT280T 14-Pin SOIC Configuration**

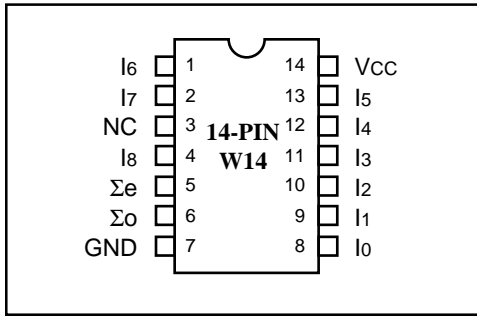

**PI74FCT280T 16-Pin QSOP Configuration**

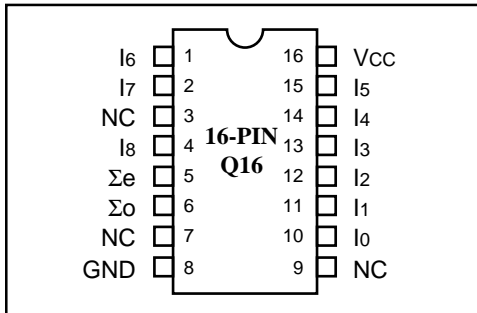

**Product Pin Description**

Pin Name	Description
I8–I0	Data In
Σe	Even Parity Out
Σo	Odd Parity Out
GND	Ground
VCC	Power

**Truth Table<sup>(1)</sup>**

Function	Inputs	Outputs	
	I8–I0	Σe	Σo
Even Parity	No. of Bits at TTL High = 0, 2, 4, 6, 8	H	L
Odd Parity	No. of Bits at TTL High = 1, 3, 5, 7, 9	L	H

**Note:**

- H = High Voltage Level  
L = Low Voltage Level

**Maximum Ratings**

(Above which the useful life may be impaired. For user guidelines, not tested.)

Storage Temperature .....	–65°C to +150°C
Ambient Temperature with Power Applied .....	–40°C to +85°C
Supply Voltage to Ground Potential (Inputs & Vcc Only) .....	–0.5V to +7.0V
Supply Voltage to Ground Potential (Outputs & D/O Only) .....	–0.5V +7.0V
DC Input Voltage .....	–0.5V to +7.0V
DC Output Current .....	120 mA
Power Dissipation .....	0.5W

**Note:**

Stresses greater than those listed under MAXIMUM RATINGS may cause permanent damage to the device. This is a stress rating only and functional operation of the device at these or any other conditions above those indicated in the operational sections of this specification is not implied. Exposure to absolute maximum rating conditions for extended periods may affect reliability.

**Capacitance** (TA = 25°C, f = 1 MHz)

Parameters <sup>(1)</sup>	Description	Test Conditions	Typ	Max.	Units
CIN	Input Capacitance	VIN = 0V	6	10	pF
COU	Output Capacitance	VOUT = 0V	8	12	pF

**Notes:**

- This parameter is determined by device characterization but is not production tested.

**DC Electrical Characteristics** (Over the Operating Range,  $T_A = -40^{\circ}\text{C}$  to  $+85^{\circ}\text{C}$ ,  $V_{CC} = 5\text{V} \pm 5\%$ )

Parameters	Description	Test Conditions <sup>(1)</sup>		Min	Typ <sup>(2)</sup>	Max	Units
$V_{OH}$	Output HIGH Voltage	$V_{CC} = \text{Min.}, V_{IN} = V_{IH} \text{ or } V_{IL}$	$I_{OH} = -15.0 \text{ mA}$	2.4	3.0		V
$V_{OL}$	Output LOW Current	$V_{CC} = \text{Min.}, V_{IN} = V_{IH} \text{ or } V_{IL}$	$I_{OL} = 48 \text{ mA}$		0.3	0.50	V
$V_{IH}$	Input HIGH Voltage	Guaranteed Logic HIGH Level		2.0			V
$V_{IL}$	Input LOW Voltage	Guaranteed Logic LOW Level				0.8	V
$I_{IH}$	Input HIGH Current	$V_{CC} = \text{Max.}$	$V_{IN} = V_{CC}$			1	$\mu\text{A}$
$I_{IL}$	Input LOW Current	$V_{CC} = \text{Max.}$	$V_{IN} = \text{GND}$			-1	$\mu\text{A}$
$V_{IK}$	Clamp Diode Voltage	$V_{CC} = \text{Min.}, I_{IN} = -18 \text{ mA}$			-0.7	-1.2	V
$I_{OS}$	Short Circuit Current	$V_{CC} = \text{Max.}^{(3)}, V_{OUT} = \text{GND}$		-60	-120		mA
$I_{OFF}$	Power Down Disable	$V_{CC} = \text{GND}, V_{OUT} = 4.5\text{V}$		—	—	100	$\mu\text{A}$
$V_H$	Input Hysteresis				200		mV

**Notes:**

1. For Max. or Min. conditions, use appropriate value specified under Electrical Characteristics for applicable device type.
2. Typical values are at  $V_{CC} = 5.0\text{V}$ ,  $+25^{\circ}\text{C}$  ambient and maximum loading.
3. Not more than one output should be shorted at one time. Duration of the test should not exceed one second.

**Switching Characteristics over Operating Range**

Parameters	Description	Conditions <sup>(1)</sup>	280T		280AT		280BT		280CT		Unit
			Com.		Com.		Com.		Com.		
			Min	Max	Min	Max	Min	Max	Min	Max	
$t_{PHLE}$	Propagation Delay $I_0 - I_8$ to $\Sigma_{\text{even}}$	$C_L = 50 \text{ pF}$ $R_L = 500\Omega$	3.0	10.0	3.0	7.5	3.0	6.3	3.0	5.3	ns
$t_{PHLO}$			3.0	10.0	3.0	7.5	3.0	6.3	3.0	5.3	ns
$t_{PLHE}$	Propagation Delay $I_0 - I_8$ to $\Sigma_{\text{odd}}$		3.0	10.0	3.0	7.5	3.0	6.3	3.0	5.3	ns
$t_{PLHO}$			3.0	10.0	3.0	7.5	3.0	6.3	3.0	5.3	ns

**Notes:**

1. See test circuit and waveforms.
2. Minimum limits are guaranteed but not tested on Propagation Delays.

**Power Supply Characteristics**

Parameters	Description	Test Conditions <sup>(1)</sup>		Min.	Typ <sup>(2)</sup>	Max.	Units
I <sub>CC</sub>	Quiescent Power Supply Current	V <sub>CC</sub> = Max.	V <sub>IN</sub> = GND or V <sub>CC</sub>		0.1	500	μA
ΔI <sub>CC</sub>	Supply Current per Input @ TTL HIGH	V <sub>CC</sub> = Max.	V <sub>IN</sub> = 3.4V <sup>(3)</sup>			2.0	mA
I <sub>CCD</sub>	Supply Current per Input per MHz <sup>(4)</sup>	V <sub>CC</sub> = Max., Outputs Open One Input Toggling 50% Duty Cycle	V <sub>IN</sub> = V <sub>CC</sub> V <sub>IN</sub> = GND			0.25	mA/ MHz
I <sub>C</sub>	Total Power Supply Current <sup>(6)</sup>	V <sub>CC</sub> = Max., Outputs Open f <sub>CP</sub> = 10 MHz 50% Duty Cycle f <sub>i</sub> = 5 MHz One Bit Toggling	V <sub>IN</sub> = V <sub>CC</sub> V <sub>IN</sub> = GND		1.7	4.0 <sup>(5)</sup>	mA
			V <sub>IN</sub> = 3.4V V <sub>IN</sub> = GND		2.2	6.0 <sup>(5)</sup>	
		V <sub>CC</sub> = Max., Outputs Open f <sub>CP</sub> = 10 MHz 50% Duty Cycle Nine Bits Toggling f <sub>i</sub> = 2.5 MHz 50% Duty Cycle	V <sub>IN</sub> = V <sub>CC</sub> V <sub>IN</sub> = GND		4.0	7.8 <sup>(5)</sup>	
			V <sub>IN</sub> = 3.4V V <sub>IN</sub> = GND		6.2	16.8 <sup>(5)</sup>	

**Notes:**

- For Max. or Min. conditions, use appropriate value specified under Electrical Characteristics for the applicable device.
- Typical values are at V<sub>CC</sub> = 5.0V, +25°C ambient.
- Per TTL driven input (V<sub>IN</sub> = 3.4V); all other inputs at V<sub>CC</sub> or GND.
- This parameter is not directly testable, but is derived for use in Total Power Supply Calculations.
- Values for these conditions are examples of the I<sub>CC</sub> formula. These limits are guaranteed but not tested.
- I<sub>C</sub> = I<sub>QUIESCENT</sub> + I<sub>INPUTS</sub> + I<sub>DYNAMIC</sub>  
 $I_C = I_{CC} + \Delta I_{CC} D_H N_T + I_{CCD} (f_{CP}/2 + f_i N_i)$   
 I<sub>CC</sub> = Quiescent Current  
 ΔI<sub>CC</sub> = Power Supply Current for a TTL High Input (V<sub>IN</sub> = 3.4V)  
 D<sub>H</sub> = Duty Cycle for TTL Inputs High  
 N<sub>T</sub> = Number of TTL Inputs at D<sub>H</sub>  
 I<sub>CCD</sub> = Dynamic Current Caused by an Input Transition Pair (HLH or LHL)  
 f<sub>CP</sub> = Clock Frequency for Register Devices (Zero for Non-Register Devices)  
 f<sub>i</sub> = Input Frequency  
 N<sub>i</sub> = Number of Inputs at f<sub>i</sub>  
 All currents are in milliamps and all frequencies are in megahertz.