

C-MOS STEP-UP SWITCHING REGULATOR

■ GENERAL DESCRIPTION

The **NJU7262 series** is a C-MOS step-up switching regulator which contains accurate voltage reference, error amplifier, CR oscillator, control circuit, switching transistor, diode and resistor.

The operating clock is prepared on-chip or is available to input from external, and the stand-by function is effective for low power consumption.

The regulation voltage is fixed by internal circuits and the following line-up of different output voltages version are available.

This series is suitable for portable equipment's or battery operated items because of its small packaged outline, low operating voltage and current.

■ FEATURES

- Low Operating Voltage (1.0V min.)
- Low Operating Current (5.0 μ A typ. / $V_{OUT} = 3.0V$)
- Low Stand-by Current (0.2 μ A max. / $V_{OUT} = 3.0V$)
- High Precision Output Voltage ($\pm 3\%$ max.)
- Wide Operating Voltage Range
- External/Internal Clock Select Function
- Stand-by Function
- CR Oscillator On-chip
- Diode On-chip
- Package Outline DMP-8/SSOP-8/VSP-8
- C-MOS Technology

■ LINE-UP

Output Voltage (V)	Package		
	DMP-8	SSOP-8	VSP-8
3.0	NJU7262M30	NJU7262V30	NJU7262R30
5.0	NJU7262M50	NJU7262V50	NJU7262R50

■ TERMINAL DESCRIPTION

No.	Term. Name	I/O	FUNCTION
1	CONT	I	External Inductor Connect Terminal
2	GND	POWER	Power Source (GND)
3	NC	-	Non Connect
4	STB	I	Strobe Terminal : "H" or OPEN ...Normal Operation (step-up) " L " ...Standp-By Operation
5	V_{IN}	POWER	Power Source (+)
6	SW	I	External / Internal Clock Select Terminal "H" or OPEN...Internal Oscillation "L" ...External Clock Input (When "L" level is input, Internal oscillation is stopped)
7	CLK	I	External Clock Input Terminal
8	V_{OUT}	O	Step-up Output Terminal

■ PACKAGE OUTLINE



NJU7262MXX



NJU7262VXX



NJU7262RXX

■ PIN CONFIGURATION

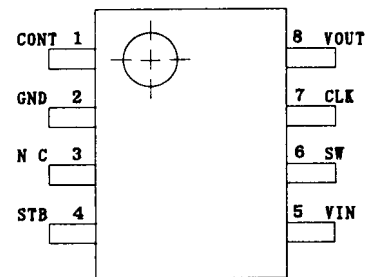

■ EQUIVALENT CIRCUIT

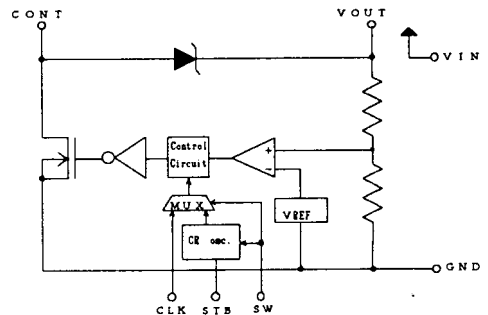

NJU7262 Series

■ ABSOLUTE MAXIMUM RATINGS

(T_a = 25°C)

PARAMETER	SYMBOL	RATINGS	UNIT
Input Voltage	V _{IN}	10	V
CONT Input Voltage	V _{CONT}	GND-0.3 ≤ V _{CONT} ≤ 10	V
STB, SW, CLK Input Voltage	V _I	GND-0.3 ≤ V _I ≤ V _{IN}	V
Output Voltage	V _{OUT}	GND-0.3 ≤ V _{OUT} ≤ 10	V
Power Dissipation	P _D	(DMP-8) 300 (SSOP-8) 250 (VSP-8) 320	mW
Operating Temperature Range	T _{opr}	-25 to +75	°C
Storage Temperature Range	T _{stg}	-40 to +125	°C

Note) Decoupling capacitor should be connected between V_{DD} and V_{SS} due to the stabilized operation for the voltage converter.

■ ELECTRICAL CHARACTERISTICS

+3V Version

(T_a = 25°C)

PARAMETER	SYMBOL		CONDITION	NORM			UNIT	MEASUREMENT CIRCUIT
				MIN.	TYP.	MAX.		
Input Voltage	V _{IN}			-	-	5.0	V	1
Start Voltage	V _{START}		NO LOAD	-	-	1.0	V	1
Oscillator Freq.	f _{OSC}		V _{IN} = 1.5V	20	30	50	kHz	2
Output Voltage	V _{OUT}		V _{IN} = 1.5V, I _{OUT} = 20mA	2.91	3.0	3.09	V	1
Input Stability	ΔV _{OUT1}		V _{IN} = 1.5V to 2.0V I _{OUT} = 20mA	-	30	100	mV	1
Load Stability	ΔV _{OUT2}		V _{IN} = 1.5V I _{OUT} = 10μA to 25mA	-	30	100	mV	1
Operating Current	I _{SS}		V _{IN} = V _{STB} = 1.5V, NO LOAD	-	5.0	10	μA	3
Stand-by Current	I _Q		V _{IN} = V _{SW} = 1.5V V _{STB} = V _{CLK} = 0V, NO LOAD	-	-	0.2	μA	4
Switching Current	I _{SI}		V _{DS} = 0.2V	-	250	-	mA	-
STB Terminal Input Voltage	H level	V _{STBH}	V _{IN} = 1.5V	1.0	-	-	V	5
	L level	V _{STBL}	V _{IN} = 1.5V	-	-	0.4	V	5
SW Terminal Input Voltage	H level	V _{SWH}	V _{IN} = 1.5V	1.0	-	-	V	6
	L level	V _{SWL}	V _{IN} = 1.5V	-	-	0.4	V	6
CLK Terminal Input Voltage	H level	V _{CLKH}	V _{IN} = 1.5V	1.0	-	-	V	7
	L level	V _{CLKL}	V _{IN} = 1.5V	-	-	0.4	V	7
STB Terminal Input Current	H level	I _{STBH1}	V _{IN} = 1.5V, V _{STB} = 1.0V	-	15	30	μA	8
		I _{STBH2}	V _{IN} = 1.5V, V _{STB} = 1.5V	-	0.1	-	μA	8
	L level	I _{STBL1}	V _{IN} = 1.5V, V _{STB} = 0.4V	-	15	30	μA	8
		I _{STBL2}	V _{IN} = 1.5V, V _{STB} = 0V	-	0.1	-	μA	8
SW Terminal Input Current	H level	I _{SWH}	V _{IN} = 1.5V, V _{SW} = V _{IN}	-	0.1	-	μA	8
	L level	I _{SWL}	V _{IN} = 1.5V, V _{SW} = 0V	-	10	30	μA	8
CLK Terminal Input Current	H level	I _{CLKH}	V _{IN} = 1.5V, V _{CLK} = V _{IN}	-	10	30	μA	8
	L level	I _{CLKL}	V _{IN} = 1.5V, V _{CLK} = 0V	-	0.1	-	μA	8

NJU7262 Series

+5V Version

(T_a = 25°C)

PARAMETER	SYMBOL		CONDITION	NORM			UNIT	MEASUREMENT CIRCUIT
				MIN.	TYP.	MAX.		
Input Voltage	V _{IN}			-	-	5.0	V	1
Start Voltage	V _{START}		NO LOAD	-	-	1.0	V	1
Oscillator Freq.	f _{OSC}		V _{IN} = 3.0V	20	30	50	kHz	2
Output Voltage	V _{OUT}		V _{IN} = 3.0V, I _{OUT} = 20mA	4.85	5.0	5.15	V	1
Input Stability	ΔV _{OUT1}		V _{IN} = 2.0V to 3.0V I _{OUT} = 20mA	-	30	100	mV	1
Load Stability	ΔV _{OUT2}		V _{IN} = 3.0V I _{OUT} = 10μA to 25mA	-	30	100	mV	1
Operating Current	I _{SS}		V _{IN} = V _{STB} = 3.0V, NO LOAD	-	5	15	μA	3
Stand-by Current	I _Q		V _{IN} = V _{SW} = 3.0V V _{STB} = V _{CLK} = 0V, NO LOAD	-	-	0.2	μA	4
Switching Current	I _{SI}		V _{DS} = 0.2V	-	250	-	mA	-
STB Terminal Input Voltage	H level	V _{STBH}	V _{IN} = 3.0V	2.4	-	-	V	5
	L level	V _{STBL}	V _{IN} = 3.0V	-	-	0.4	V	5
SW Terminal Input Voltage	H level	V _{SWH}	V _{IN} = 3.0V	2.4	-	-	V	6
	L level	V _{SWL}	V _{IN} = 3.0V	-	-	0.4	V	6
CLK Terminal Input Voltage	H level	V _{CLKH}	V _{IN} = 3.0V	2.4	-	-	V	7
	L level	V _{CLKL}	V _{IN} = 3.0V	-	-	0.4	V	7
STB Terminal Input Current	H level	I _{STBH1}	V _{IN} = 3.0V, V _{STB} = 2.4V	-	50	100	μA	8
		I _{STBH2}	V _{IN} = 3.0V, V _{STB} = 3.0V	-	0.1	-	μA	8
	L level	I _{STBL1}	V _{IN} = 3.0V, V _{STB} = 0.4V	-	50	100	μA	8
		I _{STBL2}	V _{IN} = 3.0V, V _{STB} = 0V	-	0.1	-	μA	8
SW Terminal Input Current	H level	I _{SWH}	V _{IN} = 3.0V, V _{SW} = V _{IN}	-	0.1	-	μA	8
	L level	I _{SWL}	V _{IN} = 3.0V, V _{SW} = 0V	-	10	30	μA	8
CLK Terminal Input Current	H level	I _{CLKH}	V _{IN} = 3.0V, V _{CLK} = V _{IN}	-	10	30	μA	8
	L level	I _{CLKL}	V _{IN} = 3.0V, V _{CLK} = 0V	-	0.1	-	μA	8

NJU7262 Series

MEASUREMENT CIRCUIT

(1)

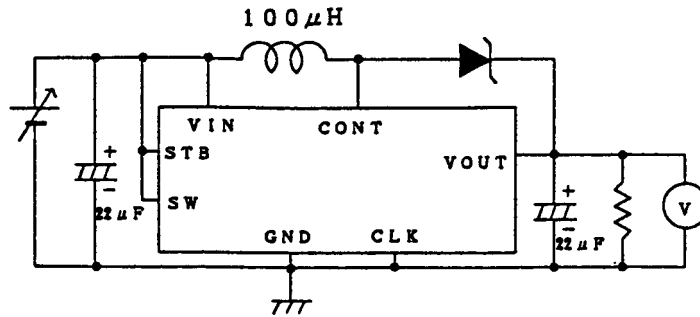

External Diode Type : "D1NS4" provided by SHINDENGEN
 ($I_F = 1A, V_F = 0.55V$)

(2)

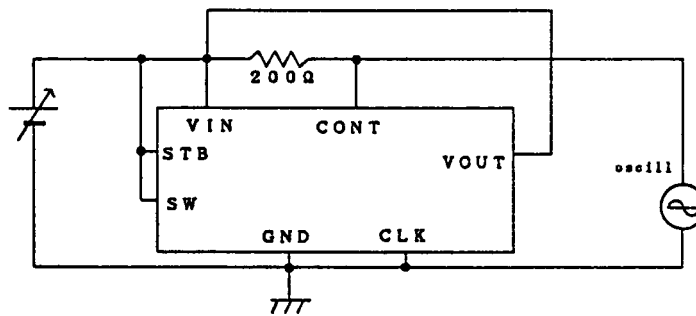

(3)

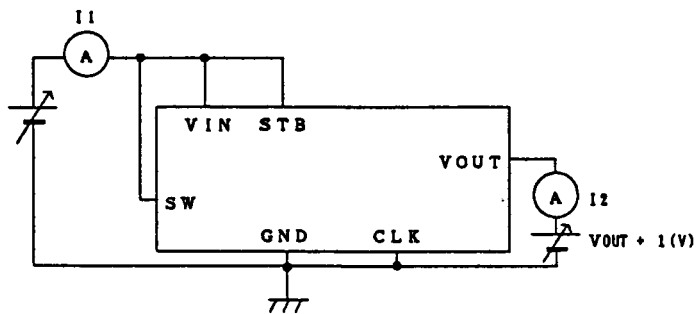

$$I_{SS} = I_1 + I_2 \times \frac{V_{OUT}}{V_{OUT} + 1}$$

(4)

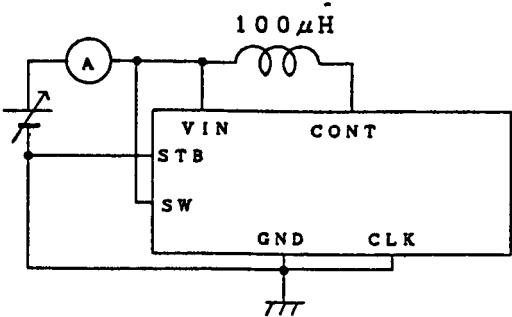

(5)

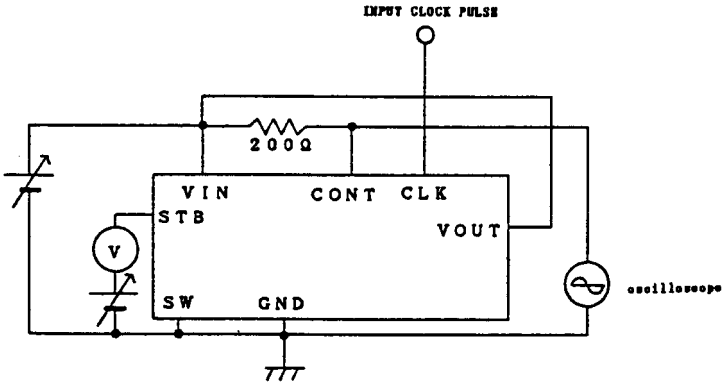

(6)

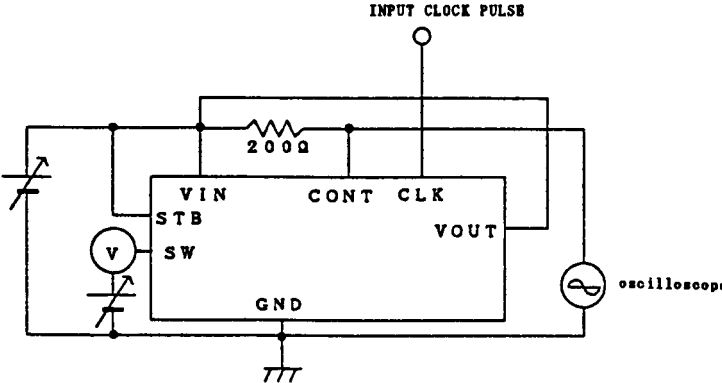

NJU7262 Series

(7)

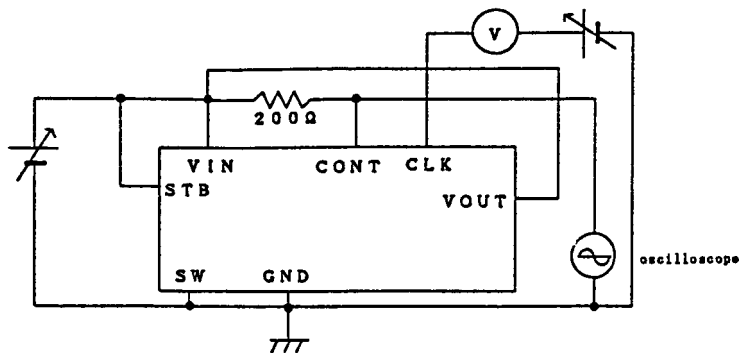

(8)

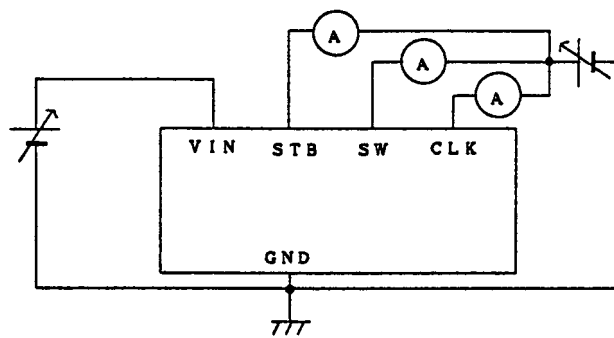

■ APPLICATION CIRCUIT

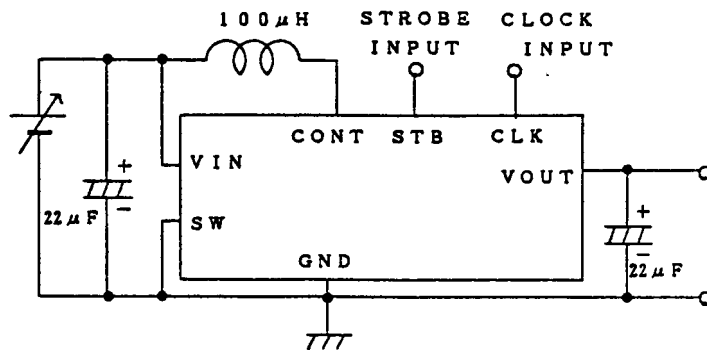

[CAUTION]
 The specifications on this databook are only given for information, without any guarantee as regards either mistakes or omissions. The application circuits in this databook are described only to show representative usages of the product and not intended for the guarantee or permission of any right including the industrial rights.