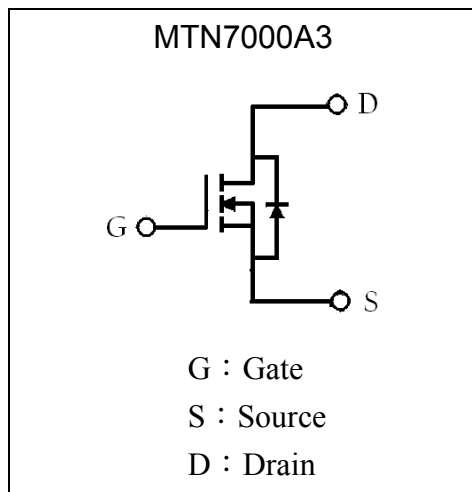
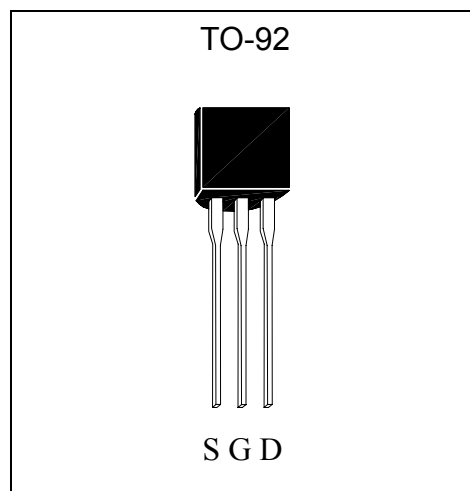

N-CHANNEL MOSFET

MTN7000A3

Description

The MTN7000A3 is a N-channel enhancement-mode MOSFET.

Symbol

Outline

Absolute Maximum Ratings (Ta=25°C)

Parameter	Symbol	Limits	Unit
Drain-Source Voltage	V _{DSS}	60	V
Drain-Gate Voltage (R _{GS} =1MΩ)	V _{DGR}	60	V
Gate-Source Voltage	V _{GS}	±20	V
---Continuous	V _{GSM}	±40	V
---Non-repetitive(tp ≤50μs)			
Continuous Drain Current (Ta=25°C)	I _D	200	mA
Continuous Drain Current (Ta=100°C)	I _D	130	mA
Pulsed Drain Current (Ta=25°C)	I _{DM}	500 *1	mA
Total Power Dissipation (Ta=25°C)	P _d	400	mW
Derate Above 25°C		3.2	mW/°C
Operating Junction Temperature	T _j	-55~+150	°C
Storage Temperature	T _{stg}	-55~+150	°C
Thermal Resistance, Junction-to-Ambient	R _{th,ja}	312.5	°C/W
Lead Temperature, for 10 second Soldering	T _L	260	°C

Note : *1. Pulse Width ≤ 300μs, Duty cycle ≤2%



Electrical Characteristics (Ta=25°C)

Symbol	Min.	Typ.	Max.	Unit	Test Conditions
BV _{DSS}	60			V	V _{GS} =0, I _D =10μA
V _{GS(th)}	0.8		3	V	V _{DS} =V _{GS} , I _D =1.0mA
I _{GSS/F}			10	nA	V _{GS} =+15V, V _{DS} =0
I _{GSS/R}			-10	nA	V _{GS} =-15V, V _{DS} =0
I _{DSS}			1	μA	V _{DS} =48V, V _{GS} =0
I _{D(ON)}	75			mA	V _{DS} =10V, V _{GS} =4.5V
R _{DS(ON)}			5.3	Ω	I _D =75mA, V _{GS} =4.5V
			5		I _D =75mA, V _{GS} =10V
G _{FS}	100	-	-	mS	V _{DS} =10V, I _D =200mA
C _{iss}	-	-	60	pF	V _{DS} =25V, V _{GS} =0, f=1MHz
C _{oss}	-	-	25		
C _{rss}	-	-	5		

*Pulse Test : Pulse Width ≤380μs, Duty Cycle ≤2%

Characteristic Curves

TYPICAL OUTPUT CHARACTERISTICS

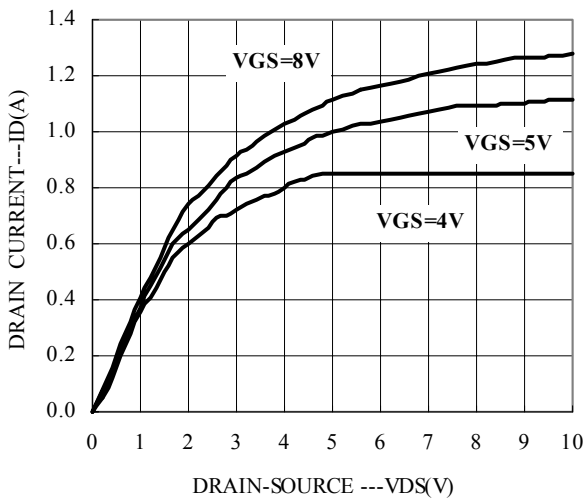

TYPICAL TRANSFER CHARACTERISTIC

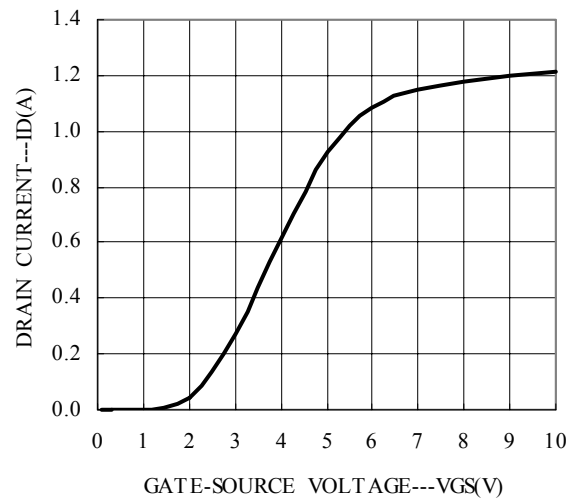



STATIC DRAIN-SOURCE ON-STATE RESISTANCE vs DRAIN CURRENT

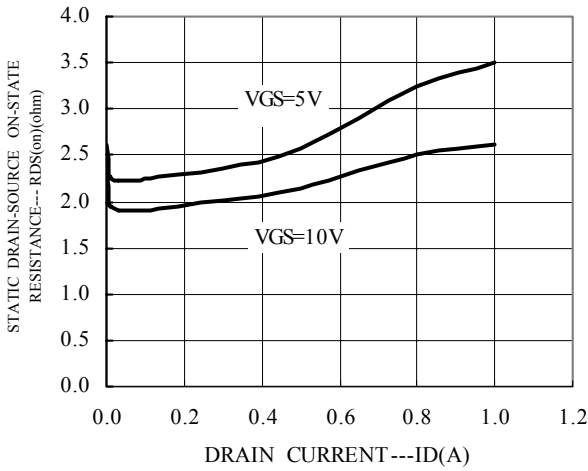

STATIC DRAIN-SOURCE ON-STATE RESISTANCE VS GATE-SOURCE VOLTAGE

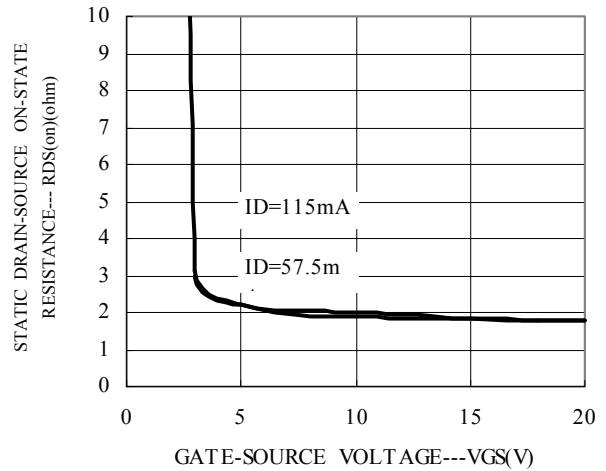

FORWARD TRANSFER ADMITTANCE vs DRAIN CURRENT

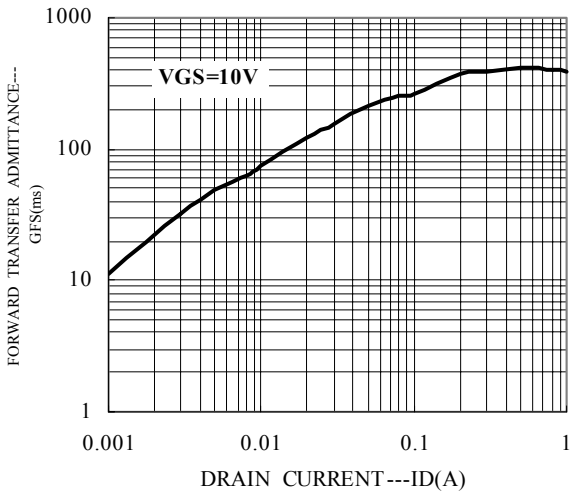

REVERSE DRAIN CURRENT vs SOURCE-DRAIN VOLTAGE

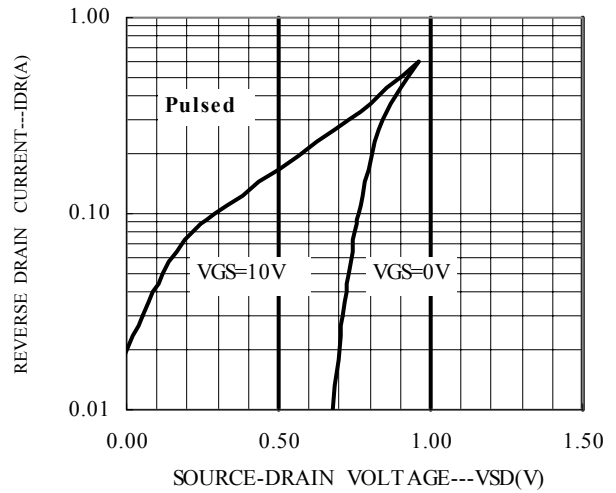

SWITCHING CHARACTERISTICS

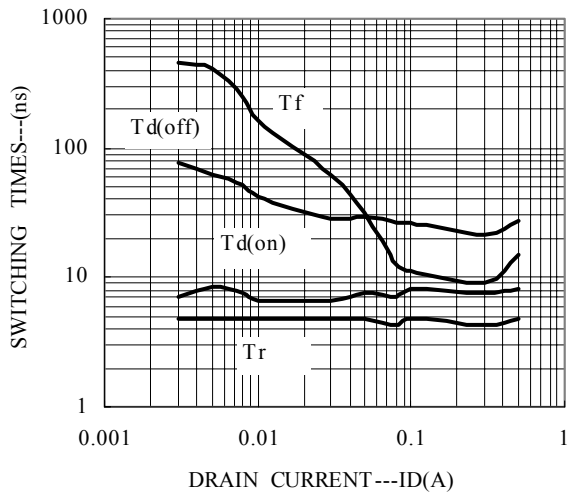

POWER DERATING CURVE

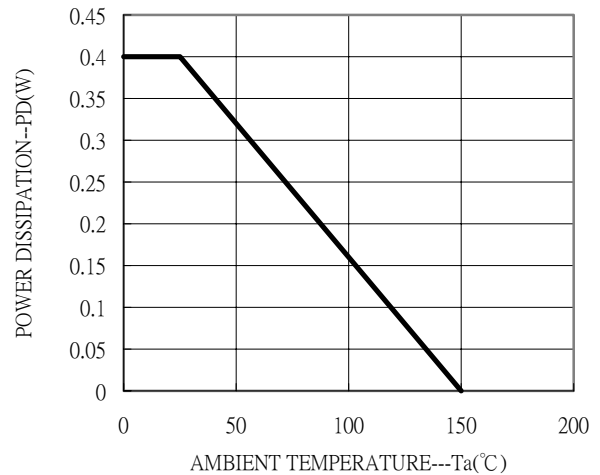

TO-92 Dimension

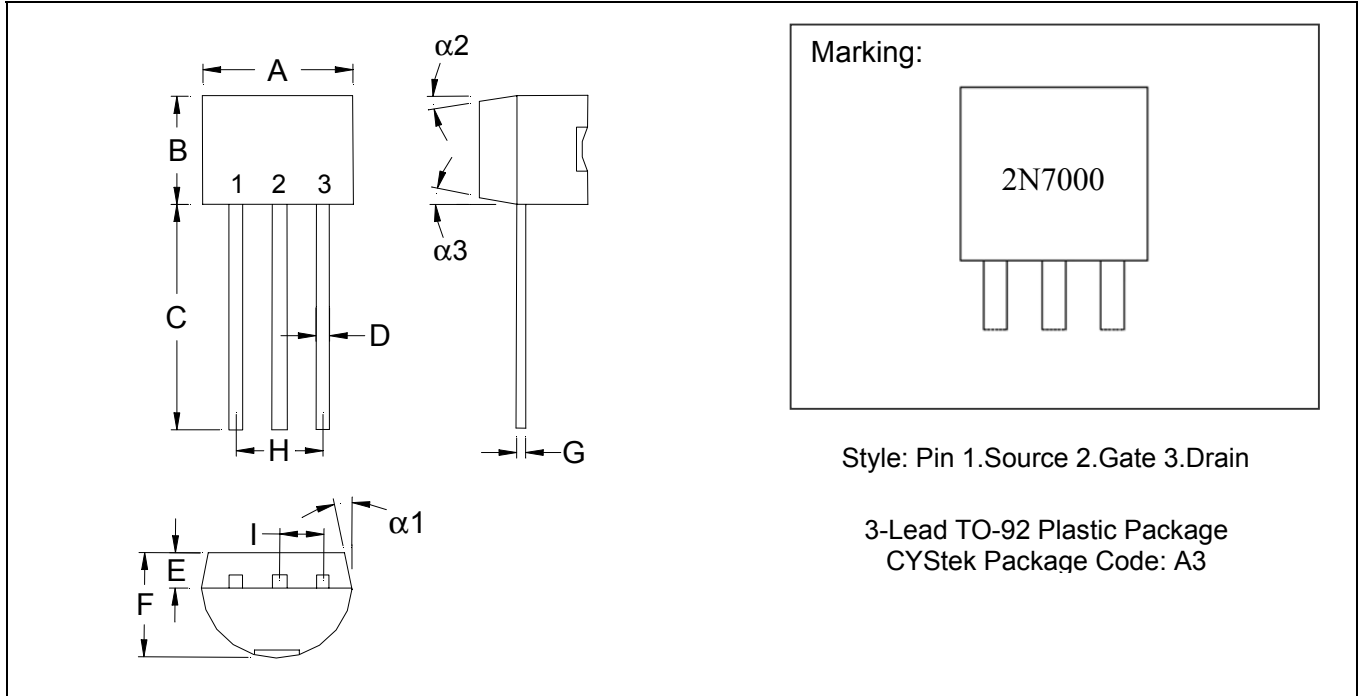

*: Typical

DIM	Inches		Millimeters		DIM	Inches		Millimeters	
	Min.	Max.	Min.	Max.		Min.	Max.	Min.	Max.
A	0.1704	0.1902	4.33	4.83	G	0.0142	0.0220	0.36	0.56
B	0.1704	0.1902	4.33	4.83	H	-	*0.1000	-	*2.54
C	0.5000	-	12.70	-	I	-	*0.0500	-	*1.27
D	0.0142	0.0220	0.36	0.56	$\alpha 1$	-	*5°	-	*5°
E	-	*0.0500	-	*1.27	$\alpha 2$	-	*2°	-	*2°
F	0.1323	0.1480	3.36	3.76	$\alpha 3$	-	*2°	-	*2°

Notes: 1.Controlling dimension: millimeters.
 2.Maximum lead thickness includes lead finish thickness, and minimum lead thickness is the minimum thickness of base material.
 3.If there is any question with packing specification or packing method, please contact your local CYStek sales office.

Material:

- Lead: 42 Alloy ; solder plating
- Mold Compound: Epoxy resin family, flammability solid burning class: UL94V-0

Important Notice:

- All rights are reserved. Reproduction in whole or in part is prohibited without the prior written approval of CYStek.
- CYStek reserves the right to make changes to its products without notice.
- CYStek **semiconductor products are not warranted to be suitable for use in Life-Support Applications, or systems.**
- CYStek assumes no liability for any consequence of customer product design, infringement of patents, or application assistance.