

# DATA SHEET

Part No.	MN88441
Package Code No.	LQFP128-P-1818C

SEMICONDUCTOR COMPANY  
MATSUSHITA ELECTRIC INDUSTRIAL CO., LTD.

# MN88441

## OFDM Demodulation LSI for Digital Terrestrial Broadcasting in Japan

### ■ Overview

This LSI is a channel decoder LSI supporting ISDB-T/ISDB-T<sub>SB</sub>.

Widely used for digital terrestrial broadcasting receiver equipment that takes advantage of UHF and VHF frequency bands in Japan.

This LSI performs the following operations:

- IF signal input
- OFDM\*<sup>1</sup> demodulation
- Error correction
- TSP\*<sup>2</sup> output

\*1 Orthogonal Frequency Division Multiplexing

\*2 Transport Stream Packet

### ■ Features

- Supports digital terrestrial broadcasting (ISDB-T) and Digital terrestrial sound broadcasting (ISDB-T<sub>SB</sub>)
- Strong suppression of co-channel interference with analog broadcasting signal
- AGC with 2 output signals (PWM output)
- On-chip CPU/IF circuits compliant with I2C bus
- On-chip ADC for input signal
- On-chip boundary scan test circuits compliant with IEEE1149.1

### ■ Applications

- Set-top box for digital terrestrial broadcasting
- TV with receiving function for digital terrestrial broadcasting
- DVHS with receiving function for digital terrestrial broadcasting

### ■ System structure block diagram

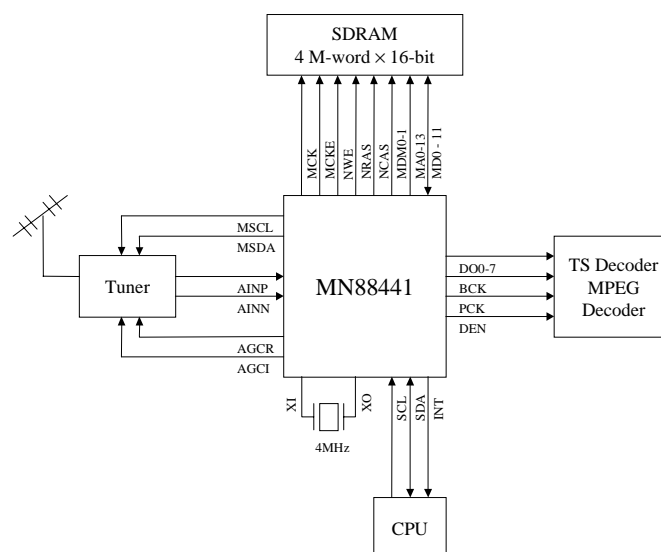

Note : The detailed information for this product is disclosed after non-disclosure agreement between your company and MEI.

## ■ LSI specifications

Modulation	Transmission mode:	Mode1, Mode2, Mode3
	Guard interval duration:	1/32, 1/16, 1/8, 1/4
	Carrier modulation:	DQPSK, QPSK, 16QAM, 64QAM
	Coding rate:	1/2, 2/3, 3/4, 5/6, 7/8
IF Input	Center frequency:	4.063 MHz
TSP output		Parallel or serial (alternative)
BER measurement output		Serial (Output from TSP pin with alternative Viterbi decode out or RS decode out)
Clock	PLL reference frequency:	4 MHz (Self-excited or clock input alternative)
	Master clock frequency:	40 MHz
CPU Interface		Compliant with standard I2C bus mode Tuner control with I2C format
External memory		64 M-bit, 128 M-bit, 256 M-bit SDRAM (larger than 4 M-word × 16-bit)
Supply voltage	For external I/F:	3.3 V
	For internal section:	1.8 V
Input voltage		3.3 V (LVTTL)
Output voltage		3.3 V (LVCMOS)
Package		128-pin LQFP (□ 18 mm, 0.5 mm pitch)

■ LSI block diagram

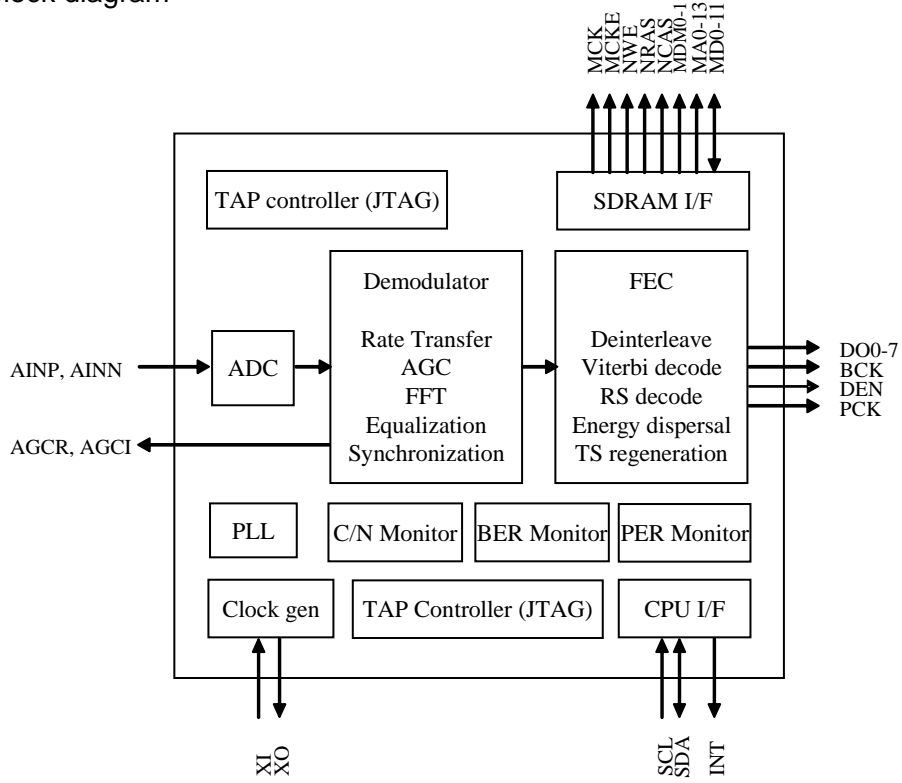

## Request for your special attention and precautions in using the technical information and semiconductors described in this material

- (1) An export permit needs to be obtained from the competent authorities of the Japanese Government if any of the products or technical information described in this material and controlled under the "Foreign Exchange and Foreign Trade Law" is to be exported or taken out of Japan.
- (2) The technical information described in this material is limited to showing representative characteristics and applied circuits examples of the products. It neither warrants non-infringement of intellectual property right or any other rights owned by our company or a third party, nor grants any license.
- (3) We are not liable for the infringement of rights owned by a third party arising out of the use of the technical information as described in this material.
- (4) The products described in this material are intended to be used for standard applications or general electronic equipment (such as office equipment, communications equipment, measuring instruments and household appliances).  
Consult our sales staff in advance for information on the following applications:
  - Special applications (such as for airplanes, aerospace, automobiles, traffic control equipment, combustion equipment, life support systems and safety devices) in which exceptional quality and reliability are required, or if the failure or malfunction of the products may directly jeopardize life or harm the human body.
  - Any applications other than the standard applications intended.
- (5) The products and product specifications described in this material are subject to change without notice for modification and/or improvement. At the final stage of your design, purchasing, or use of the products, therefore, ask for the most up-to-date Product Standards in advance to make sure that the latest specifications satisfy your requirements.
- (6) When designing your equipment, comply with the guaranteed values, in particular those of maximum rating, the range of operating power supply voltage, and heat radiation characteristics. Otherwise, we will not be liable for any defect which may arise later in your equipment.  
Even when the products are used within the guaranteed values, take into the consideration of incidence of break down and failure mode, possible to occur to semiconductor products. Measures on the systems such as redundant design, arresting the spread of fire or preventing glitch are recommended in order to prevent physical injury, fire, social damages, for example, by using the products.
- (7) When using products for which damp-proof packing is required, observe the conditions (including shelf life and amount of time let standing of unsealed items) agreed upon when specification sheets are individually exchanged.
- (8) This material may be not reprinted or reproduced whether wholly or partially, without the prior written permission of Matsushita Electric Industrial Co., Ltd.