

UTC MJE2955T PNP EPITAXIAL SILICON TRANSISTOR

HIGH VOLTAGE TRANSISTOR

DESCRIPTION

The UTC MJE2955T is designed for general purpose of amplifier and switching applications.

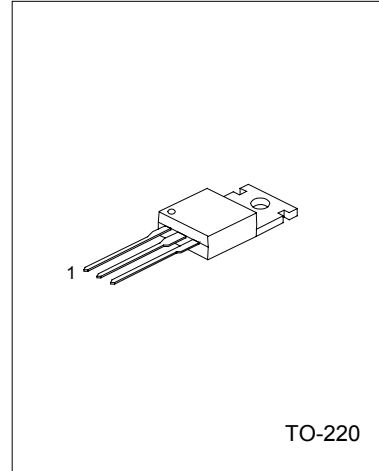

TO-220

1:BASE 2: COLLECTOR 3: EMITTER

ABSOLUTE MAXIMUM RATINGS (Operating temperature range applies unless otherwise specified)

PARAMETER	SYMBOL	RATING	UNIT
Collector-base voltage	V _{CB0}	70	V
Collector-emitter voltage	V _{CEO}	60	V
Emitter-base voltage	V _{EBO}	5	V
Total Power Dissipation(T _a =25°C)	P _c	75	W
Collector current	I _c	10	A
Junction Temperature	T _j	150	°C
Storage Temperature	T _{STG}	-55 ~ +150	°C
Base Current	I _B	6	A

ELECTRICAL CHARACTERISTICS(T_a=25°C,unless otherwise specified)

PARAMETER	SYMBOL	TEST CONDITIONS	MIN	TYP	MAX	UNIT
Collector-emitter breakdown voltage	V _{CEO}	I _c =200mA	60			V
Collector-Base Breakdown Voltage	V _{CB0}	I _c =10mA	70			V
Emitter-Base Breakdown Voltage	V _{EBO}	I _E =10mA	5			V
Collector cut-off current	I _{CB0}	V _{CB} =70V			1	mA
	I _{CE0}	V _{CE} =30V			700	μA
	I _{CEx}	V _{CE} =70V, V _{EB(off)} =1.5V			1	mA
Emitter cut-off current	I _{EBO}	V _{EB} =5V			5	mA
Collector-emitter saturation voltage	V _{CE(SAT)1}	I _c =4A, I _B =0.4A			1.1	V
	V _{CE(SAT)2}	I _c =10A, I _B =3.3A			8.0	V
Base-emitter on voltage	V _{BE(ON)}	V _{CE} =4V, I _c =4A			1.8	V
DC current gain	h _{FE1}	I _c =4A, V _{CE} =4V	20		100	
	h _{FE2}	I _c =10A, V _{CE} =4V	5			
Current gain bandwidth product	f _T	V _{CE} =10V, I _c =0.5A, f=1MHz	2			MHZ

UTC MJE2955T PNP EPITAXIAL SILICON TRANSISTOR

TYPICAL CHARACTERISTIC

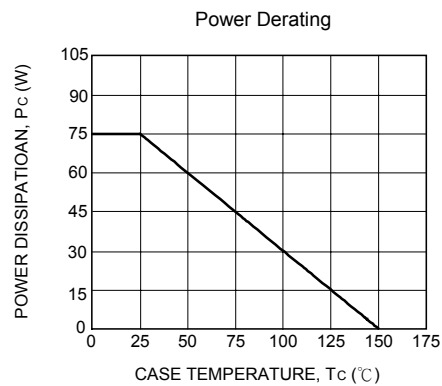
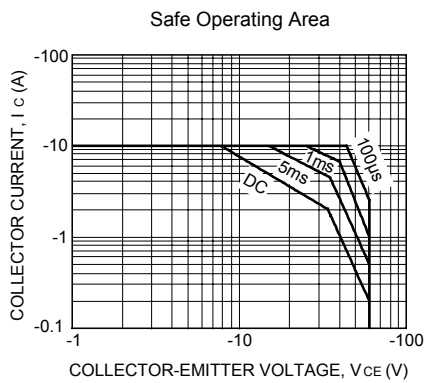
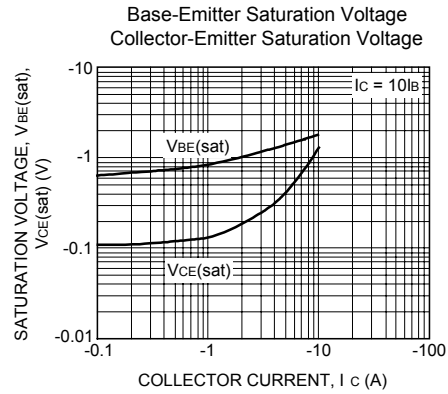
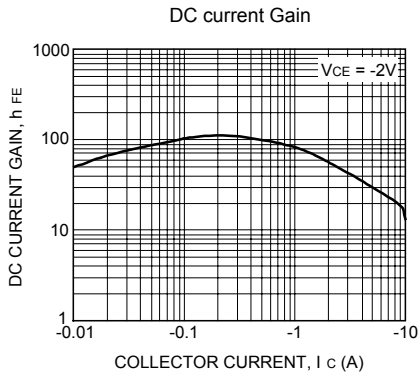

UTC assumes no responsibility for equipment failures that result from using products at values that exceed, even momentarily, rated values (such as maximum ratings, operating condition ranges, or other parameters) listed in products specifications of any and all UTC products described or contained herein. UTC products are not designed for use in life support appliances, devices or systems where malfunction of these products can be reasonably expected to result in personal injury. Reproduction in whole or in part is prohibited without the prior written consent of the copyright owner. The information presented in this document does not form part of any quotation or contract, is believed to be accurate and reliable and may be changed without notice.