

## MF699 ST



ST Assembly

Ordering Information	
PART #	RECEPTACLE
MF699	ST
-40°C to +85°C	

### Applications

- Ethernet 10 or 100Mbps
- Token Ring
- Fibre Channel 266Mbps
- FDDI
- ATM-SDH/SONET 155Mbps
- Intra-Office Telecom
- WDM Applications

### Features

- Full Duplex Communication Over One Fiber
- Dual Wavelengths 820/1300nm
- Very Small Size
- Very Low Internal Crosstalk
- Packaged in Industry-Standard ST® Receptacle
- Designed for 62.5/125µm Fiber

### Description

Used in combination with the MF799, the MF699 Duplex Device is designed for WDM

(Wavelength Division Multiplex), Datacom, Video Links, or Intra-Office Telecom Applications. It emits optical power at 1320nm and detects incoming optical power at 820nm, allowing full Duplex Communication over one single fiber.

The MF699 uses dichroic (wavelength-selective) beamsplitters for maximum power budget and minimum crosstalk. Minimum internal crosstalk is achieved with wavelength-selective detectors. The long wavelength path meets requirements for FDDI (ANSI X3T9.5) and ATM 155Mbps.

The MF699 is designed for multi-mode fiber and optimized for 62.5/125µm fiber.

## MF699 Functional Diagram

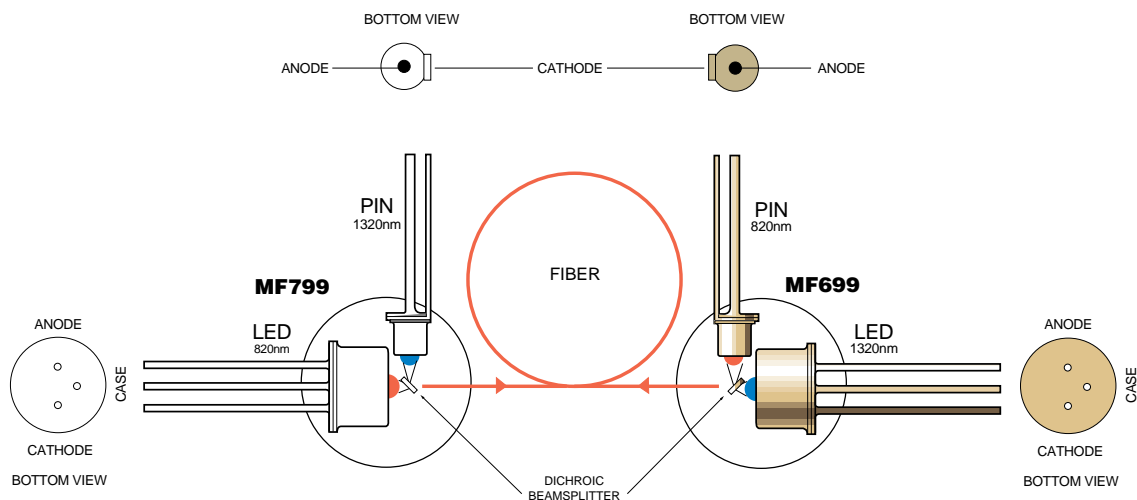

**Absolute Maximum Ratings\***

Parameter	Symbol	Min.	Max.	Units
Storage Temperature	T <sub>stg</sub>	-40	+85	°C
Operating Temperature (Fig 2)	T <sub>op</sub>	-40	+85	°C
LED Power Dissipation (Fig 2)	P <sub>tot</sub>		160	mW
LED Continuous Forward Current (f≤10kHz)	I <sub>F</sub>		80	mA
LED Peak Forward Current (duty cycle ≤50%, f≥1MHz)	I <sub>FRM</sub>		130	mA
LED Reverse Voltage	V <sub>RL</sub>		0.5	V
PIN Reverse Voltage	V <sub>RP</sub>		20	V
Soldering Temperature (Note 1)	T <sub>sld</sub>		260	°C

\*Exceeding these values may cause permanent damage. Functional operation under these conditions is not implied. Note 1: 2mm from the case for 10s.

**LED Optical & Electrical Characteristics (Case Temperature -25 to +70°C)**

Parameter	Symbol	Min.	Typ.	Max.	Units	Test Conditions
Fiber-Coupled-Power (Fig 1)	P <sub>fiber</sub>	-20.5			dBm	I <sub>Peak</sub> =60mA (Note 1, 2)
Rise & Fall Time (10-90% no bias)	t <sub>r</sub> t <sub>f</sub>		2.5		ns	I <sub>F</sub> =60mA (Note 2, 3)
Bandwidth (3dB <sub>e</sub> )	f <sub>c</sub>		125		MHz	I <sub>F</sub> =60mA (Note 2)
Peak Wavelength	λ <sub>p</sub>		1320		nm	I <sub>F</sub> =60mA (Note 3)
Spectral Width (FWHM)	Δλ		135		nm	I <sub>F</sub> =60mA (Note 3)
Forward Voltage (Fig 3)	V <sub>F</sub>		1.3	1.65	V	I <sub>F</sub> =60mA
Reverse Current	I <sub>R</sub>			100	μA	V <sub>R</sub> =1V
Capacitance	C		200		pF	V <sub>R</sub> =0V, f=1MHz

Note 1: Average power at 10MHz/50% duty cycle. Measured at the exit of 100m of fiber.

Note 2: 62.5/125μm graded index fiber (NA=0.275). Note 3: Meets the FDDI ANSI X3T9.5 specification.

**PIN Optical & Electrical Characteristics (Case Temperature -25 to +70°C)**

Parameter	Symbol	Min.	Typ.	Max.	Units	Test Conditions
Responsivity (Fig 4)	R	0.25			A/W	V <sub>R</sub> =5V λ=820nm (Note 1)
Bandwidth	f <sub>c</sub>	500			MHz	V <sub>R</sub> =5V R <sub>L</sub> =50Ω (Note 1)
Capacitance (Fig 5)	C		1		pF	V <sub>R</sub> =5V f=1MHz
Dark Current	I <sub>d</sub>			3 50	nA	T <sub>Case</sub> =25°C T <sub>Case</sub> =70°C V <sub>R</sub> =5V I <sub>LED</sub> =0mA
Crosstalk Current	I <sub>Cr</sub>		3		nA	V <sub>R</sub> =5V I <sub>LED</sub> =60mA (Note 2)

Note 1: 62.5/125μm graded index fiber (NA=0.275). Note 2: Internal crosstalk with ceramic ferrule inserted but no power from the fiber. Total Current = Dark Current + Crosstalk Current.

**LED Thermal Characteristics**

Parameter	Symbol	Min.	Typ.	Max.	Units
Thermal Resistance - Infinite Heat Sink	R <sub>thjc</sub>			200	°C/W
Thermal Resistance - On PC Board	R <sub>thjb</sub>			300	°C/W
Temperature Coefficient - Optical Power	dP/dT <sub>j</sub>		-0.75		%/°C
Temperature Coefficient - Wavelength	dλ/dT <sub>j</sub>		0.45		nm/°C

**PIN Thermal Characteristics**

Parameter	Symbol	Min.	Typ.	Max.	Units
Temperature Coefficient - Dark Current	dI <sub>d</sub> /dT <sub>j</sub>		5		%/°C
Temperature Coefficient - Crosstalk Current	dI <sub>Cr</sub> /dT <sub>j</sub>		-0.75		%/°C

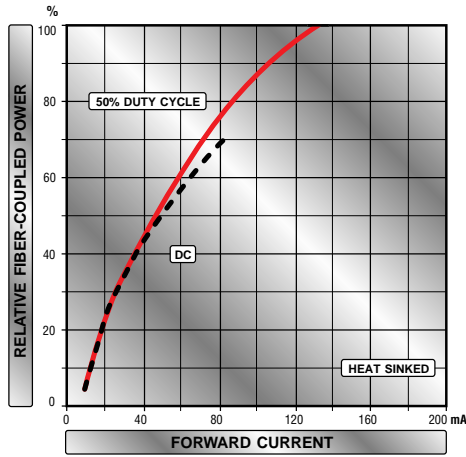

Figure 1

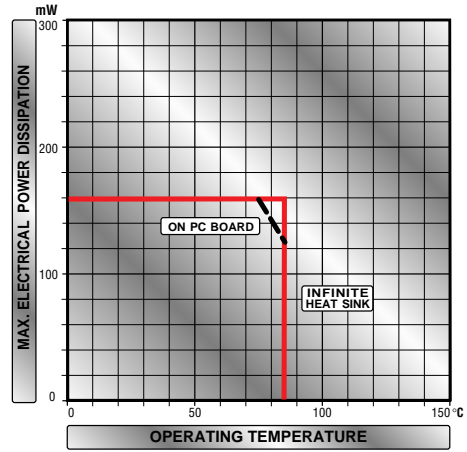

Figure 2

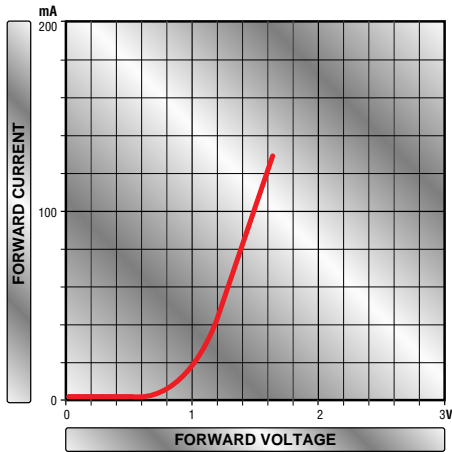

Figure 3

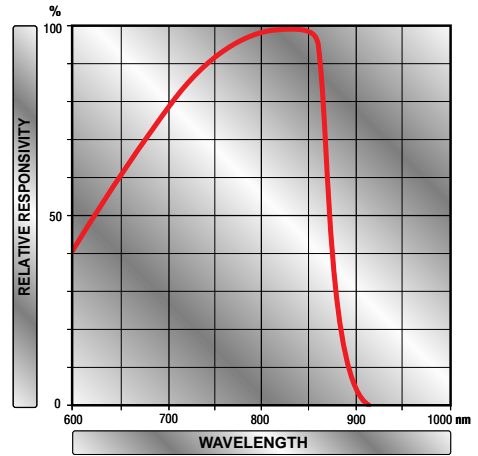

Figure 4

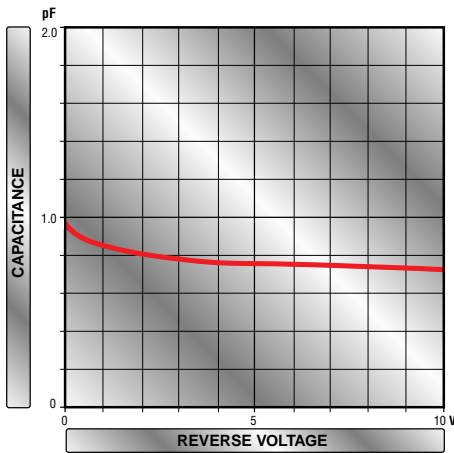
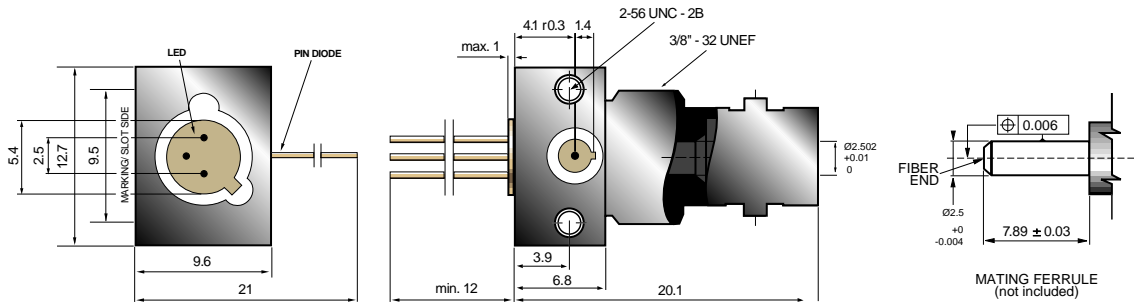

Figure 5

**MF699 Mechanical Data**



Note: The LED chip is isolated from the case. All dimensions in mm.

**Packaging Hardware**

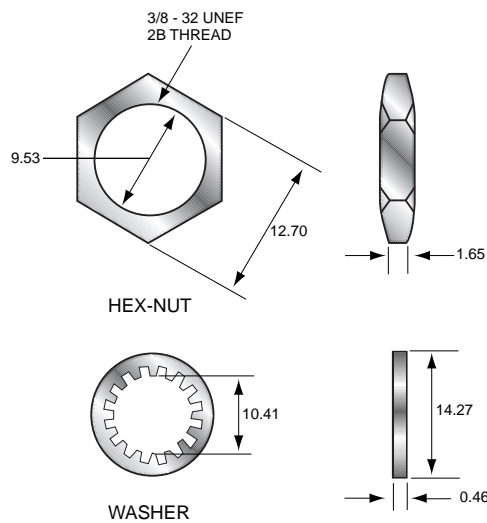



<http://www.mitelsemi.com>

**World Headquarters - Canada**

Tel: +1 (613) 592 2122  
Fax: +1 (613) 592 6909

**North America**

Tel: +1 (770) 486 0194  
Fax: +1 (770) 631 8213

**Asia/Pacific**

Tel: +65 333 6193  
Fax: +65 333 6192

**Europe, Middle East,  
and Africa (EMEA)**

Tel: +44 (0) 1793 518528  
Fax: +44 (0) 1793 518581

Information relating to products and services furnished herein by Mitel Corporation or its subsidiaries (collectively "Mitel") is believed to be reliable. However, Mitel assumes no liability for errors that may appear in this publication, or for liability otherwise arising from the application or use of any such information, product or service or for any infringement of patents or other intellectual property rights owned by third parties which may result from such application or use. Neither the supply of such information or purchase of product or service conveys any license, either express or implied, under patents or other intellectual property rights owned by Mitel or licensed from third parties by Mitel, whatsoever. Purchasers of products are also hereby notified that the use of product in certain ways or in combination with Mitel, or non-Mitel furnished goods or services may infringe patents or other intellectual property rights owned by Mitel.

This publication is issued to provide information only and (unless agreed by Mitel in writing) may not be used, applied or reproduced for any purpose nor form part of any order or contract nor to be regarded as a representation relating to the products or services concerned. The products, their specifications, services and other information appearing in this publication are subject to change by Mitel without notice. No warranty or guarantee express or implied is made regarding the capability, performance or suitability of any product or service. Information concerning possible methods of use is provided as a guide only and does not constitute any guarantee that such methods of use will be satisfactory in a specific piece of equipment. It is the user's responsibility to fully determine the performance and suitability of any equipment using such information and to ensure that any publication or data used is up to date and has not been superseded. Manufacturing does not necessarily include testing of all functions or parameters. These products are not suitable for use in any medical products whose failure to perform may result in significant injury or death to the user. All products and materials are sold and services provided subject to Mitel's conditions of sale which are available on request.

M Mitel (design) and ST-BUS are registered trademarks of MITEL Corporation  
Mitel Semiconductor is an ISO 9001 Registered Company  
Copyright 1999 MITEL Corporation  
All Rights Reserved  
Printed in CANADA

TECHNICAL DOCUMENTATION - NOT FOR RESALE