



**MC68HC08BD24**  
HCMOS Microcontroller Unit

TECHNICAL DATA



**Freescale Semiconductor, Inc.**

**Freescale Semiconductor, Inc.**

**For More Information On This Product,  
Go to: [www.freescale.com](http://www.freescale.com)**

## List of Sections

Section 1. General Description .....	21
Section 2. Memory Map .....	31
Section 3. Random-Access Memory (RAM) .....	49
Section 4. Read-Only Memory (ROM) .....	51
Section 5. Configuration Register (CONFIG) .....	53
Section 6. Central Processor Unit (CPU) .....	57
Section 7. System Integration Module (SIM) .....	77
Section 8. Oscillator (OSC) .....	101
Section 9. Monitor ROM (MON) .....	105
Section 10. Timer Interface Module (TIM) .....	115
Section 11. Pulse Width Modulator (PWM) .....	137
Section 12. Analog-to-Digital Converter (ADC) .....	143
Section 13. DDC12AB Interface .....	153
Section 14. Sync Processor .....	169
Section 15. Input/Output (I/O) Ports .....	189
Section 16. External Interrupt (IRQ) .....	211
Section 17. Computer Operating Properly (COP) .....	217
Section 18. Break Module (BRK) .....	223
Section 19. Electrical Specifications .....	231
Section 20. Mechanical Specifications .....	239



## Table of Contents

### Section 1. General Description

1.1	Contents . . . . .	21
1.2	Introduction . . . . .	21
1.3	Features . . . . .	22
1.4	MCU Block Diagram . . . . .	23
1.5	Pin Assignments . . . . .	25
1.6	Pin Functions . . . . .	27

### Section 2. Memory Map

2.1	Contents . . . . .	31
2.2	Introduction . . . . .	31
2.3	Unimplemented Memory Locations . . . . .	31
2.4	Reserved Memory Locations . . . . .	32
2.5	Input/Output (I/O) Section . . . . .	32

### Section 3. Random-Access Memory (RAM)

3.1	Contents . . . . .	49
3.2	Introduction . . . . .	49
3.3	Functional Description . . . . .	49

### Section 4. Read-Only Memory (ROM)

4.1	Contents . . . . .	51
4.2	Introduction . . . . .	51
4.3	Functional Description . . . . .	51

**Section 5. Configuration Register (CONFIG)**

5.1 Contents . . . . . 53

5.2 Introduction . . . . . 53

5.3 Configuration Register 0 . . . . . 54

5.4 Configuration Register 1 . . . . . 55

**Section 6. Central Processor Unit (CPU)**

6.1 Contents . . . . . 57

6.2 Introduction . . . . . 57

6.3 Features . . . . . 58

6.4 CPU Registers . . . . . 58

6.4.1 Accumulator . . . . . 59

6.4.2 Index Register . . . . . 60

6.4.3 Stack Pointer . . . . . 60

6.4.4 Program Counter . . . . . 61

6.4.5 Condition Code Register . . . . . 61

6.5 Arithmetic/Logic Unit (ALU) . . . . . 64

6.6 Low-Power Modes . . . . . 64

6.6.1 Wait Mode . . . . . 64

6.6.2 Stop Mode . . . . . 65

6.7 CPU During Break Interrupts . . . . . 65

6.8 Instruction Set Summary . . . . . 65

6.9 Opcode Map . . . . . 65

**Section 7. System Integration Module (SIM)**

7.1 Contents . . . . . 77

7.2 Introduction . . . . . 78

7.3 SIM Bus Clock Control and Generation . . . . . 81

7.3.1 Bus Timing . . . . . 81

7.3.2 Clock Start-Up from POR . . . . . 81

7.3.3	Clocks in Stop Mode and Wait Mode . . . . .	81
7.4	Reset and System Initialization. . . . .	82
7.4.1	External Pin Reset . . . . .	82
7.4.2	Active Resets from Internal Sources . . . . .	83
7.4.2.1	Power-On Reset . . . . .	84
7.4.2.2	Computer Operating Properly (COP) Reset . . . . .	85
7.4.2.3	Illegal Opcode Reset . . . . .	86
7.4.2.4	Illegal Address Reset. . . . .	86
7.5	SIM Counter . . . . .	86
7.5.1	SIM Counter During Power-On Reset . . . . .	86
7.5.2	SIM Counter During Stop Mode Recovery. . . . .	87
7.5.3	SIM Counter and Reset States. . . . .	87
7.6	Exception Control . . . . .	87
7.6.1	Interrupts . . . . .	88
7.6.1.1	Hardware Interrupts . . . . .	90
7.6.1.2	SWI Instruction. . . . .	91
7.6.2	Interrupt Status Registers. . . . .	91
7.6.2.1	Interrupt Status Register 1 . . . . .	93
7.6.2.2	Interrupt Status Register 2. . . . .	93
7.6.3	Reset . . . . .	94
7.6.4	Break Interrupts . . . . .	94
7.6.5	Status Flag Protection in Break Mode . . . . .	94
7.7	Low-Power Modes . . . . .	95
7.7.1	Wait Mode . . . . .	95
7.7.2	Stop Mode . . . . .	96
7.8	SIM Registers . . . . .	98
7.8.1	SIM Break Status Register (SBSR) . . . . .	98
7.8.2	SIM Reset Status Register (SRSR) . . . . .	99
7.8.3	SIM Break Flag Control Register (SBFCR) . . . . .	100

**Section 8. Oscillator (OSC)**

8.1	Contents . . . . .	101
8.2	Introduction. . . . .	101
8.3	Oscillator External Connections . . . . .	102

8.4 I/O Signals ..... 103

8.4.1 Crystal Amplifier Input Pin (OSC1) ..... 103

8.4.2 Crystal Amplifier Output Pin (OSC2) ..... 103

8.4.3 Oscillator Enable Signal (SIMOSCEN) ..... 103

8.4.4 External Clock Source (OSCXCLK) ..... 103

8.4.5 Oscillator Out (OSCOUT) ..... 103

8.5 Low Power Modes ..... 104

8.5.1 Wait Mode ..... 104

8.5.2 Stop Mode ..... 104

8.6 Oscillator During Break Mode ..... 104

**Section 9. Monitor ROM (MON)**

9.1 Contents ..... 105

9.2 Introduction ..... 105

9.3 Features ..... 106

9.4 Functional Description ..... 106

9.4.1 Entering Monitor Mode ..... 108

9.4.2 Data Format ..... 109

9.4.3 Echoing ..... 110

9.4.4 Break Signal ..... 110

9.4.5 Commands ..... 111

9.4.6 Baud Rate ..... 114

**Section 10. Timer Interface Module (TIM)**

10.1 Contents ..... 115

10.2 Introduction ..... 116

10.3 Features ..... 116

10.4 Pin Name Conventions ..... 116

10.5 Functional Description ..... 117

10.5.1 TIM Counter Prescaler ..... 119

10.5.2 Input Capture ..... 119

10.5.3 Output Compare ..... 119



10.5.3.1 Unbuffered Output Compare ..... 120

10.5.3.2 Buffered Output Compare ..... 121

10.5.4 Pulse Width Modulation (PWM) ..... 121

10.5.4.1 Unbuffered PWM Signal Generation ..... 122

10.5.4.2 Buffered PWM Signal Generation ..... 123

10.5.4.3 PWM Initialization ..... 124

10.6 Interrupts ..... 125

10.7 Wait Mode ..... 125

10.8 TIM During Break Interrupts ..... 126

10.9 I/O Signals ..... 126

10.10 I/O Registers ..... 127

10.10.1 TIM Status and Control Register (TSC) ..... 127

10.10.2 TIM Counter Registers (TCNTH:TCNTL) ..... 129

10.10.3 TIM Counter Modulo Registers (TMODH:TMODL) ..... 130

10.10.4 TIM Channel Status and Control Registers (TSC0:TSC1) ..... 131

10.10.5 TIM Channel Registers (TCH0H/L:TCH1H/L) ..... 135

**Section 11. Pulse Width Modulator (PWM)**

11.1 Contents ..... 137

11.2 Introduction ..... 137

11.3 Functional Description ..... 137

11.4 PWM Registers ..... 139

11.4.1 PWM Data Registers 0 to 15 (0PWM–15PWM) ..... 140

11.4.2 PWM Control Registers 1 and 2 (PWMCR1:PWMCR2) .. 141

**Section 12. Analog-to-Digital Converter (ADC)**

12.1 Contents ..... 143

12.2 Introduction ..... 143

12.3 Features ..... 144

12.4 Functional Description ..... 144

12.4.1 ADC Port I/O Pins ..... 145

12.4.2 Voltage Conversion .....146

12.4.3 Conversion Time .....146

12.4.4 Continuous Conversion .....146

12.4.5 Accuracy and Precision .....147

12.5 Interrupts.....147

12.6 Low-Power Modes .....147

12.6.1 Wait Mode .....147

12.6.2 Stop Mode .....147

12.7 I/O Signals .....147

12.7.1 ADC Voltage In (ADCVIN) .....148

12.8 I/O Registers.....148

12.8.1 ADC Status and Control Register.....148

12.8.2 ADC Data Register.....150

12.8.3 ADC Input Clock Register .....151

**Section 13. DDC12AB Interface**

13.1 Contents.....153

13.2 Introduction.....153

13.3 Features .....154

13.4 I/O Pins.....154

13.5 DDC Protocols .....156

13.6 Registers.....156

13.6.1 DDC Address Register (DADR) .....156

13.6.2 DDC2 Address Register (D2ADR) .....157

13.6.3 DDC Control Register (DCR) .....158

13.6.4 DDC Master Control Register (DMCR) .....159

13.6.5 DDC Status Register (DSR).....162

13.6.6 DDC Data Transmit Register (DDTR) .....164

13.6.7 DDC Data Receive Register (DDRR).....165

13.7 Programming Considerations.....166

## Section 14. Sync Processor

14.1	Contents .....	169
14.2	Introduction .....	170
14.3	Features .....	170
14.4	I/O Pins .....	171
14.5	Functional Blocks .....	173
14.5.1	Polarity Detection .....	174
14.5.1.1	Hsync Polarity Detection .....	174
14.5.1.2	Vsync Polarity Detection .....	174
14.5.1.3	Composite Sync Polarity Detection .....	174
14.5.2	Sync Signal Counters .....	175
14.5.3	Polarity Controlled HSYNCO and VSYNCO Outputs .....	175
14.5.4	Clamp Pulse Output .....	176
14.5.5	Low Vertical Frequency Detect .....	177
14.6	Registers .....	177
14.6.1	Sync Processor Control & Status Register (SPCSR) .....	177
14.6.2	Sync Processor Input/Output Control Register (SPIOCR) .....	179
14.6.3	Vertical Frequency Registers (VFRs) .....	181
14.6.4	Hsync Frequency Registers (HFRs) .....	183
14.6.5	Sync Processor Control Register 1 (SPCR1) .....	185
14.6.6	H&V Sync Output Control Register (HVOCR) .....	186
14.7	System Operation .....	187

## Section 15. Input/Output (I/O) Ports

15.1	Contents .....	189
15.2	Introduction .....	190
15.3	Port A .....	193
15.3.1	Port A Data Register .....	193
15.3.2	Data Direction Register A .....	194
15.3.3	Port A Options .....	195
15.4	Port B .....	196
15.4.1	Port B Data Register .....	196

15.4.2 Data Direction Register B .....197

15.4.3 Port B Options .....198

15.5 Port C .....199

15.5.1 Port C Data Register .....199

15.5.2 Data Direction Register C .....200

15.5.3 Port C Options .....201

15.6 Port D .....202

15.6.1 Port D Data Register .....202

15.6.2 Data Direction Register D .....203

15.6.3 Port D Options .....205

15.7 Port E .....206

15.7.1 Port E Data Register .....206

15.7.2 Data Direction Register E .....207

15.7.3 Port E Options .....209

**Section 16. External Interrupt (IRQ)**

16.1 Contents .....211

16.2 Introduction .....211

16.3 Features .....211

16.4 Functional Description .....212

16.5  $\overline{\text{IRQ}}$  Pin .....214

16.6 IRQ Module During Break Interrupts .....215

16.7 IRQ Status and Control Register .....215

**Section 17. Computer Operating Properly (COP)**

17.1 Contents .....217

17.2 Introduction .....217

17.3 Functional Description .....218

17.4 I/O Signals .....219

17.4.1 OSCXCLK .....219

17.4.2 STOP Instruction .....219

17.4.3 COPCTL Write . . . . . 219

17.4.4 Power-On Reset . . . . . 219

17.4.5 Internal Reset . . . . . 220

17.4.6 Reset Vector Fetch . . . . . 220

17.4.7 COPD (COP Disable) . . . . . 220

17.4.8 COPRS (COP Rate Select) . . . . . 220

17.5 COP Control Register . . . . . 221

17.6 Interrupts . . . . . 221

17.7 Monitor Mode . . . . . 221

17.8 Low-Power Modes . . . . . 221

17.8.1 Wait Mode . . . . . 222

17.8.2 Stop Mode . . . . . 222

17.9 COP Module During Break Mode . . . . . 222

**Section 18. Break Module (BRK)**

18.1 Contents . . . . . 223

18.2 Introduction . . . . . 223

18.3 Features . . . . . 224

18.4 Functional Description . . . . . 224

18.4.1 Flag Protection During Break Interrupts . . . . . 226

18.4.2 CPU During Break Interrupts . . . . . 226

18.4.3 TIM During Break Interrupts . . . . . 226

18.4.4 COP During Break Interrupts . . . . . 226

18.5 Low-Power Modes . . . . . 226

18.5.1 Wait Mode . . . . . 226

18.5.2 Stop Mode . . . . . 227

18.6 Break Module Registers . . . . . 227

18.6.1 Break Status and Control Register . . . . . 227

18.6.2 Break Address Registers . . . . . 228

18.6.3 SIM Break Status Register . . . . . 228

18.6.4 SIM Break Flag Control Register . . . . . 230

**Section 19. Electrical Specifications**

19.1 Contents . . . . . 231

19.2 Introduction . . . . . 231

19.3 Absolute Maximum Ratings . . . . . 232

19.4 Functional Operating Range . . . . . 233

19.5 Thermal Characteristics . . . . . 233

19.6 DC Electrical Characteristics . . . . . 234

19.7 Control Timing . . . . . 235

19.8 Oscillator Characteristics . . . . . 235

19.9 ADC Characteristics . . . . . 236

19.10 Timer Interface Module Characteristics . . . . . 237

19.11 Sync Processor Timing . . . . . 237

19.12 DDC12AB Timing . . . . . 238

19.12.1 DDC12AB Interface Input Signal Timing . . . . . 238

19.12.2 DDC12AB Interface Output Signal Timing . . . . . 238

**Section 20. Mechanical Specifications**

20.1 Contents . . . . . 239

20.2 Introduction . . . . . 239

20.3 44-Pin Plastic Quad Flat Pack (QFP) . . . . . 240

20.4 42-Pin Shrink Dual in-Line Package (SDIP) . . . . . 241

## List of Figures

Figure	Title	Page
1-1	MCU Block Diagram . . . . .	24
1-2	44-Pin QFP Pin Assignments . . . . .	25
1-3	42-Pin SDIP Pin Assignments . . . . .	26
2-1	Memory Map . . . . .	33
2-2	Control, Status, and Data Registers . . . . .	35
5-1	Configuration Register 0 (CONFIG0) . . . . .	54
5-2	Configuration Register 1 (CONFIG1) . . . . .	55
6-1	CPU Registers . . . . .	59
6-2	Accumulator (A) . . . . .	59
6-3	Index Register (H:X) . . . . .	60
6-4	Stack Pointer (SP) . . . . .	61
6-5	Program Counter (PC) . . . . .	61
6-6	Condition Code Register (CCR) . . . . .	62
7-1	SIM Block Diagram . . . . .	79
7-2	OSC Clock Signals . . . . .	81
7-3	External Reset Timing . . . . .	83
7-4	Internal Reset Timing . . . . .	83
7-5	Sources of Internal Reset . . . . .	84
7-6	POR Recovery . . . . .	85
7-7	Interrupt Entry . . . . .	88
7-8	Interrupt Recovery . . . . .	88
7-9	Interrupt Processing . . . . .	89
7-10	Interrupt Recognition Example . . . . .	90
7-11	Interrupt Status Register 1 (INT1) . . . . .	93
7-12	Interrupt Status Register 2 (INT2) . . . . .	93
7-13	Wait Mode Entry Timing . . . . .	95

Figure	Title	Page
7-14	Wait Recovery from Interrupt or Break . . . . .	96
7-15	Wait Recovery from Internal Reset. . . . .	96
7-16	Stop Mode Entry Timing . . . . .	97
7-17	Stop Mode Recovery from Interrupt or Break. . . . .	97
7-18	SIM Break Status Register (SBSR) . . . . .	98
7-19	SIM Reset Status Register (SRSR) . . . . .	99
7-20	SIM Break Flag Control Register (SBFCR) . . . . .	100
8-1	Oscillator External Connections . . . . .	102
9-1	Monitor Mode Circuit. . . . .	107
9-2	Monitor Data Format. . . . .	109
9-3	Sample Monitor Waveforms . . . . .	109
9-4	Read Transaction . . . . .	110
9-5	Break Transaction. . . . .	110
10-1	TIM Block Diagram . . . . .	117
10-2	PWM Period and Pulse Width . . . . .	122
10-3	TIM Status and Control Register (TSC) . . . . .	127
10-4	TIM Counter Registers (TCNTH:TCNTL) . . . . .	130
10-5	TIM Counter Modulo Registers (TMODH:TMODL). . . . .	131
10-6	TIM Channel Status and Control Registers (TSC0:TSC1) . . . . .	132
10-7	CHxMAX Latency . . . . .	135
10-8	TIM Channel Registers (TCH0H/L:TCH1H/L). . . . .	136
11-1	PWM Data Registers 0 to 15 (0PWM–15PWM) . . . . .	140
11-2	PWM Control Register 1 and 2 (PWMCR1:PWMCR2). . . . .	141
11-3	8-Bit PWM Output Waveforms . . . . .	142
12-1	ADC Block Diagram . . . . .	145
12-2	ADC Status and Control Register (ADSCR). . . . .	148
12-3	ADC Data Register (ADR) . . . . .	150
12-4	ADC Input Clock Register (ADICLK) . . . . .	151
13-1	DDC Address Register (DADR) . . . . .	156
13-2	DDC2 Address Register (D2ADR) . . . . .	157



Figure	Title	Page
13-3	DDC Control Register (DCR) . . . . .	158
13-4	DDC Master Control Register (DMCR) . . . . .	159
13-5	DDC Status Register (DSR) . . . . .	162
13-6	DDC Data Transmit Register (DDTR) . . . . .	164
13-7	DDC Data Receive Register (DDRR) . . . . .	165
13-8	Data Transfer Sequences for Master/Slave Transmit/Receive Modes . . . . .	167
14-1	Sync Processor Block Diagram . . . . .	173
14-2	Clamp Pulse Output Timing . . . . .	176
14-3	Sync Processor Control & Status Register (SPCSR) . . . . .	177
14-4	Sync Processor Input/Output Control Register (SPIOCR) . . . . .	179
14-5	Vertical Frequency High Register . . . . .	181
14-6	Vertical Frequency Low Register . . . . .	181
14-7	Hsync Frequency High Register . . . . .	183
14-8	Hsync Frequency Low Register . . . . .	183
14-9	Sync Processor Control Register 1 (SPCR1) . . . . .	185
14-10	H&V Sync Output Control Register (HVOCR) . . . . .	186
15-1	Port A Data Register (PTA) . . . . .	193
15-2	Data Direction Register A (DDRA) . . . . .	194
15-3	Port A I/O Circuit . . . . .	194
15-4	PWM Control Register 1 (PWMCR1) . . . . .	195
15-5	Port B Data Register (PTB) . . . . .	196
15-6	Data Direction Register B (DDRB) . . . . .	197
15-7	Port B I/O Circuit . . . . .	197
15-8	PWM Control Register 1 (PWMCR1) . . . . .	198
15-9	Port C Data Register (PTC) . . . . .	199
15-10	Data Direction Register C (DDRC) . . . . .	200
15-11	Port C I/O Circuit . . . . .	200
15-12	Port D Data Register (PTD) . . . . .	202
15-13	Data Direction Register D (DDRD) . . . . .	203
15-14	Port D I/O Circuit . . . . .	204
15-15	Port D Configuration Register (PDCR) . . . . .	205
15-16	Port E Data Register (PTE) . . . . .	206
15-17	Data Direction Register E (DDRE) . . . . .	207

Figure	Title	Page
15-18	Port E I/O Circuit. . . . .	208
15-19	Configuration Register 0 (CONFIG0) . . . . .	209
16-1	IRQ Module Block Diagram . . . . .	213
16-2	IRQ Status and Control Register (INTSCR) . . . . .	216
17-1	COP Block Diagram . . . . .	218
17-2	Configuration Register 1 (CONFIG1) . . . . .	220
17-3	COP Control Register (COPCTL) . . . . .	221
18-1	Break Module Block Diagram . . . . .	225
18-2	Break Status and Control Register (BRKSCR) . . . . .	227
18-3	Break Address Register High (BRKH) . . . . .	228
18-4	Break Address Register Low (BRKL) . . . . .	228
18-5	SIM Break Status Register (SBSR) . . . . .	229
18-6	SIM Break Flag Control Register (SBFCR) . . . . .	230
19-1	ADC Input Voltage vs. Step Readings . . . . .	237
20-1	44-Pin QFP (Case 824E) . . . . .	240
20-2	42-Pin SDIP (Case 858) . . . . .	241

## List of Tables

Table	Title	Page
1-1	Pin Functions . . . . .	27
2-1	Vector Addresses . . . . .	47
6-1	Instruction Set Summary . . . . .	66
6-2	Opcode Map . . . . .	75
7-1	SIM I/O Register Summary . . . . .	80
7-2	Signal Name Conventions . . . . .	80
7-3	PIN Bit Set Timing . . . . .	82
7-4	Interrupt Sources . . . . .	92
7-5	SIM Registers Summary . . . . .	98
9-1	Mode Selection . . . . .	108
9-2	Mode Differences . . . . .	109
9-3	READ (Read Memory) Command . . . . .	111
9-4	WRITE (Write Memory) Command . . . . .	112
9-5	IREAD (Indexed Read) Command . . . . .	112
9-6	IWRITE (Indexed Write) Command . . . . .	113
9-7	READSP (Read Stack Pointer) Command . . . . .	113
9-8	RUN (Run User Program) Command . . . . .	114
9-9	Monitor Baud Rate Selection . . . . .	114
10-1	Pin Name Conventions . . . . .	116
10-2	TIM I/O Register Summary . . . . .	118
10-3	Prescaler Selection . . . . .	129
10-4	Mode, Edge, and Level Selection . . . . .	134
11-1	PWM I/O Register Summary . . . . .	138
11-2	PWM Channels and Port I/O pins . . . . .	141

Table	Title	Page
12-1	ADC Register Summary . . . . .	144
12-2	MUX Channel Select . . . . .	150
12-3	ADC Clock Divide Ratio . . . . .	151
13-1	Pin Name Conventions . . . . .	154
13-2	DDC I/O Register Summary . . . . .	155
13-3	Baud Rate Select . . . . .	161
14-1	Pin Name Conventions . . . . .	171
14-2	Sync Processor I/O Register Summary . . . . .	172
14-3	Sync Output Control . . . . .	175
14-4	Sync Output Polarity . . . . .	176
14-5	ATPOL, VINVO, and HINVO setting . . . . .	179
14-6	Sample Vertical Frame Frequencies . . . . .	182
14-7	Clamp Pulse Width . . . . .	183
14-8	HSYNC Polarity Detection Pulse Width . . . . .	185
14-9	ATPOL, VINVO, and HINVO setting . . . . .	186
14-10	Free-Running HSYNC and VSYNC Options . . . . .	187
15-1	I/O Port Register Summary . . . . .	190
15-2	Port Control Register Bits Summary . . . . .	192
15-3	Port A Pin Functions . . . . .	195
15-4	Port B Pin Functions . . . . .	198
15-5	Port C Pin Functions . . . . .	201
15-6	Port D Pin Functions . . . . .	204
15-7	Port E Pin Functions . . . . .	208
16-1	IRQ I/O Register Summary . . . . .	213
18-1	Break Module I/O Register Summary . . . . .	225

## Section 1. General Description

### 1.1 Contents

1.2	Introduction . . . . .	21
1.3	Features . . . . .	22
1.4	MCU Block Diagram . . . . .	23
1.5	Pin Assignments . . . . .	25
1.6	Pin Functions . . . . .	27

### 1.2 Introduction

The MC68HC08BD24 is a member of the low-cost, high-performance M68HC08 Family of 8-bit microcontroller units (MCUs). The M68HC08 Family is based on the customer-specified integrated circuit (CSIC) design strategy. All MCUs in the family use the enhanced M68HC08 central processor unit (CPU08) and are available with a variety of modules, memory sizes and types, and package types.

With special modules such as the sync processor, analog-to-digital converter, pulse modulator module, and DDC12AB interface, the MC68HC08BD24 is designed specifically for use in digital monitor systems.

### 1.3 Features

Features of the MC68HC08BD24 MCU include the following:

- High-performance M68HC08 architecture
- Fully upward-compatible object code with M6805, M146805, and M68HC05 families
- Low-power design; fully static with stop and wait modes
- 5V operating voltage
- 6MHz internal bus frequency, with 24MHz external crystal
- 24,576 + 512 bytes of on-chip read-only memory (ROM)
- 512 bytes of on-chip random access memory (RAM)
- Sync signal processor with the following features:
  - Horizontal and vertical frequency counters
  - Low vertical frequency indicator (40.7Hz)
  - Polarity controlled Hsync and Vsync outputs from separate sync or composite sync inputs
  - Internal generated free-running Hsync and Vsync pulses
  - CLAMP pulse output to the external pre-amp chip
- 6-channel, 8-bit analog-to-digital converter (ADC)
- 16-channel, 8-bit pulse width modulator (PWM)
- DDC12AB<sup>1</sup> module with the following:
  - DDC1 hardware
  - Multi-master IIC<sup>2</sup> hardware for DDC2AB; with dual address
- 16-bit, 2-channel timer interface module (TIM) with selectable input capture, output compare, and PWM capability on one channel

1. DDC is a VESA bus standard.

2. IIC is a proprietary Philips interface bus.

- 32 general purpose input/output (I/O) pins, including:
  - 32 shared-function I/O pins
  - 4 open-drain I/O pins
- System protection features:
  - Optional computer operating properly (COP) reset
  - Illegal opcode detection with reset
  - Illegal address detection with reset
- ROM security<sup>1</sup>
- Master reset pin with internal pull-up and power-on reset
- $\overline{\text{IRQ}}$  with programmable pull-up and schmitt-trigger input
- 42-pin SDIP and 44-pin QFP packages

Features of the CPU08 include the following:

- Enhanced HC05 Programming Model
- Extensive Loop Control Functions
- 16 Addressing Modes (Eight More Than the HC05)
- 16-Bit Index Register and Stack Pointer
- Memory-to-Memory Data Transfers
- Fast  $8 \times 8$  Multiply Instruction
- Fast 16/8 Divide Instruction
- Binary-Coded Decimal (BCD) Instructions
- Optimization for Controller Applications
- Third Party C Language Support

## 1.4 MCU Block Diagram

**Figure 1-1** shows the structure of the MC68HC08BD24.

1. No security feature is absolutely secure. However, Motorola's strategy is to make reading or copying the ROM difficult for unauthorized users.

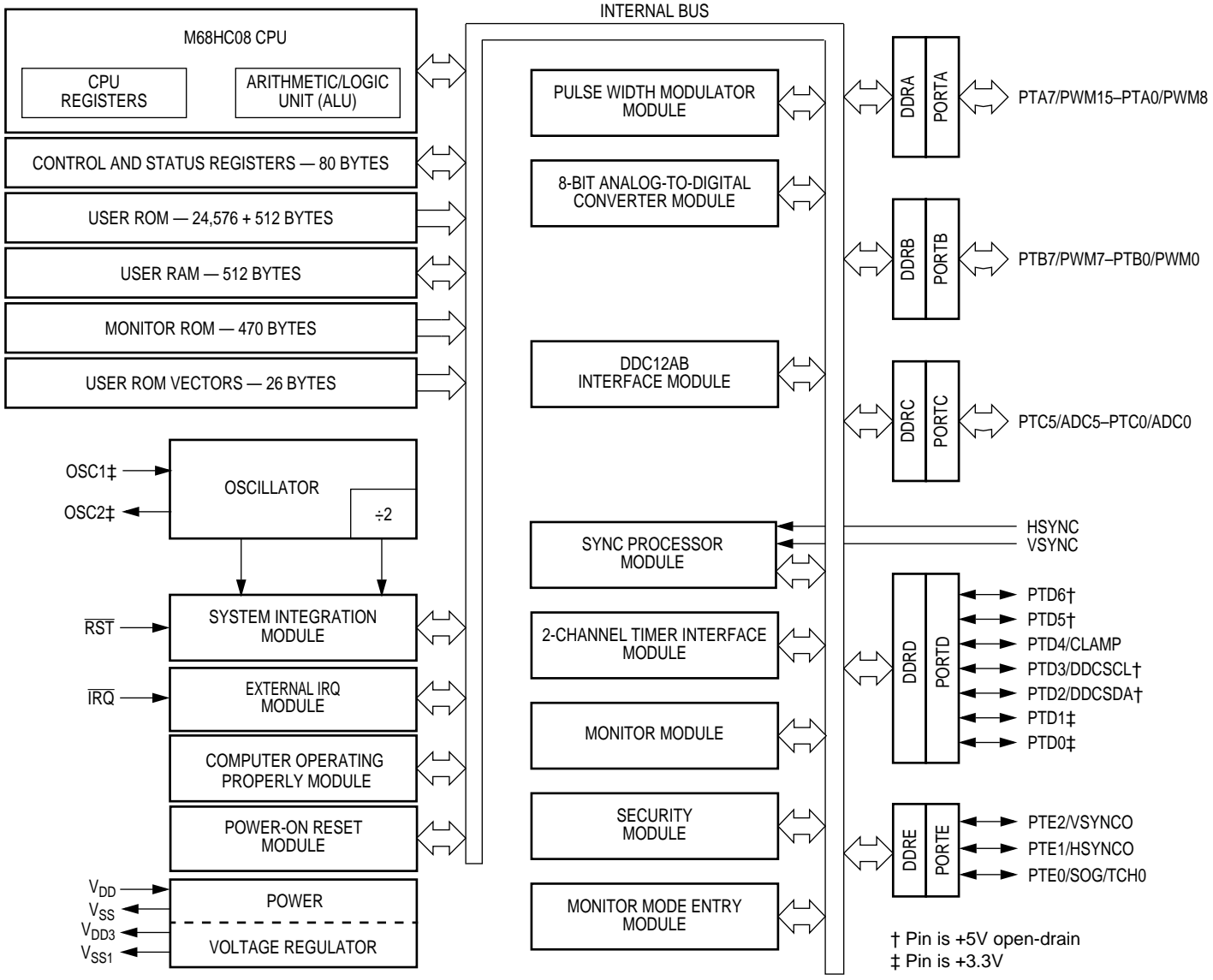
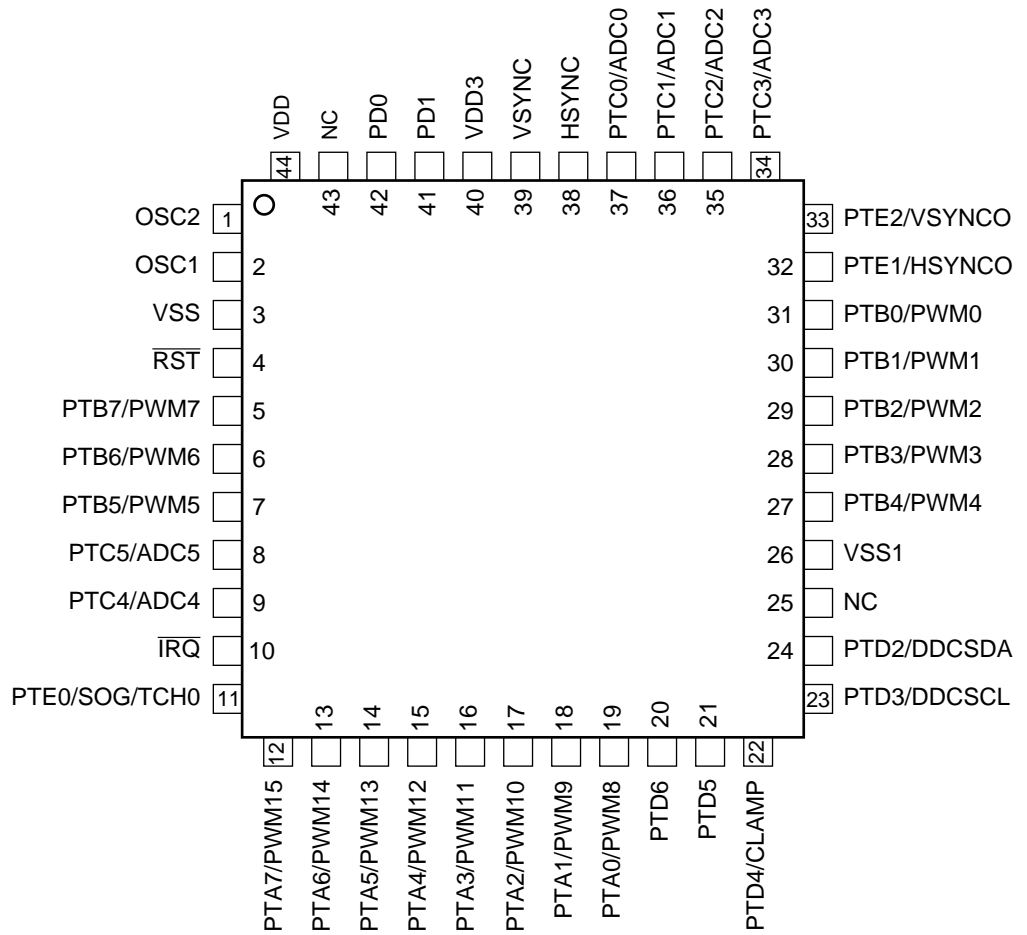

Figure 1-1. MCU Block Diagram

Freescale Semiconductor, Inc.



1.5 Pin Assignments



**NOTE:**

1. NC = No Connection
2. PTD0, PTD1, OSC1, OSC2 are 3.3V pins

**Figure 1-2. 44-Pin QFP Pin Assignments**

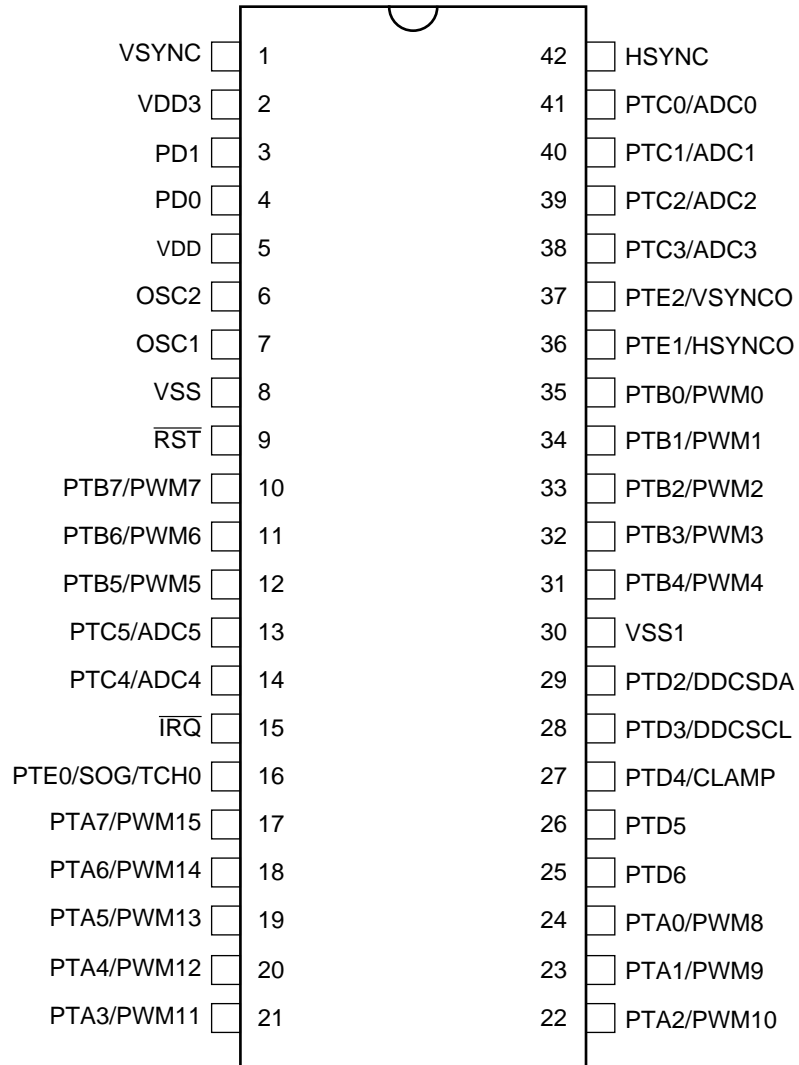

**NOTE:**

PTD0, PTD1, OSC1, OSC2 are 3.3V pins

**Figure 1-3. 42-Pin SDIP Pin Assignments**

## 1.6 Pin Functions

Description of the pin functions are provided in [Table 1-1](#).

**Table 1-1. Pin Functions**

PIN NAME	PIN DESCRIPTION
VDD	Power supply input to the MCU.
VSS	Power supply ground.
VDD3	3.3V regulated output from the MCU.
VSS1	Power supply ground.
OSC1 OSC2	Connections to the on-chip oscillator. An external clock can be connected directly to OSC1; with OSC2 floating. These are 3.3V pins. See <a href="#">Section 8. Oscillator (OSC)</a> .
$\overline{\text{RST}}$	A logic 0 on the $\overline{\text{RST}}$ pin forces the MCU to a known startup state. $\overline{\text{RST}}$ is bidirectional, allowing a reset of the entire system. It is driven low when any internal reset source is asserted. This pin contains an internal pullup resistor. See <a href="#">Section 7. System Integration Module (SIM)</a> .
$\overline{\text{IRQ}}$	External IRQ pin; with software programmable internal pull-up and schmitt trigger input. This pin is also used for mode entry selection. See <a href="#">Section 7. System Integration Module (SIM)</a> .
VSYNC	Vsync input to the sync processor. See <a href="#">Section 14. Sync Processor</a> .
HSYNC	Hsync input to the sync processor. See <a href="#">Section 14. Sync Processor</a> .
PTA7/PWM15–PTA0/PWM8	These are shared-function pins. Each pin can be configured as a standard I/O pin or a PWM output channel. See <a href="#">Section 15. Input/Output (I/O) Ports</a> and <a href="#">Section 11. Pulse Width Modulator (PWM)</a> .
PTB7/PWM7–PTB0/PWM0	These are shared-function pins. Each pin can be configured as a standard I/O pin or a PWM output channel. See <a href="#">Section 15. Input/Output (I/O) Ports</a> and <a href="#">Section 11. Pulse Width Modulator (PWM)</a> .

Table 1-1. Pin Functions

PIN NAME	PIN DESCRIPTION
PTC5/ADC5–PTC0/ADC0	These are shared-function pins. Each pin can be configured as a standard I/O pin or an ADC input channel. See <a href="#">Section 15. Input/Output (I/O) Ports</a> and <a href="#">Section 12. Analog-to-Digital Converter (ADC)</a> .
PTD6, PTD5	These two are standard I/O pins. These pins are open-drain when configured as outputs. See <a href="#">Section 15. Input/Output (I/O) Ports</a> .
PTD4/CLAMP	This is a shared function pin. It can be configured as a standard I/O pin or the clamp output from the sync processor. See <a href="#">Section 15. Input/Output (I/O) Ports</a> and <a href="#">Section 14. Sync Processor</a> .
PTD3/DDCSCL	This is a shared function pin. It can be configured as a standard I/O pin or as the clock line of the DDC12AB module. This pin is open-drain when configured as output. See <a href="#">Section 15. Input/Output (I/O) Ports</a> and <a href="#">Section 13. DDC12AB Interface</a> .
PTD2/DDCSDA	This is a shared function pin. It can be configured as a standard I/O pin or the data line of the DDC12AB module. This pin is open-drain when configured as output. See <a href="#">Section 15. Input/Output (I/O) Ports</a> and <a href="#">Section 13. DDC12AB Interface</a> .
PTD1, PTD0	These are 3.3V, standard I/O pins. See <a href="#">Section 15. Input/Output (I/O) Ports</a> .
PTE2/VSYNCO	This is a shared function pin. It can be configured as a standard I/O pin or the Hsync output from the sync processor. See <a href="#">Section 15. Input/Output (I/O) Ports</a> and <a href="#">Section 14. Sync Processor</a> .
PTE1/HSYNCO	This is a shared function pin. It can be configured as a standard I/O pin or the Vsync output from the sync processor. See <a href="#">Section 15. Input/Output (I/O) Ports</a> and <a href="#">Section 14. Sync Processor</a> .

**Table 1-1. Pin Functions**

PIN NAME	PIN DESCRIPTION
PTE0/SOG/TCH0	This is a shared function pin. It can be configured as a standard I/O pin, the SOG input to the sync processor, or the timer channel 0 I/O pin. See <a href="#">Section 15. Input/Output (I/O) Ports</a> , <a href="#">Section 14. Sync Processor</a> , and <a href="#">Section 10. Timer Interface Module (TIM)</a> .

**NOTE:** *Any unused inputs and I/O ports should be tied to an appropriate logic level (either  $V_{DD}$  or  $V_{SS}$ ;  $V_{DD3}$  or  $V_{SS}$  for 3.3V pins). Although the I/O ports of the MC68HC08BD24 do not require termination, termination is recommended to reduce the possibility of static damage.*



## Section 2. Memory Map

### 2.1 Contents

2.2	Introduction . . . . .	31
2.3	Unimplemented Memory Locations . . . . .	31
2.4	Reserved Memory Locations . . . . .	32
2.5	Input/Output (I/O) Section. . . . .	32

### 2.2 Introduction

The CPU08 can address 64 Kbytes of memory space. The memory map, shown in **Figure 2-1**, includes:

- 24,576 + 512 bytes of read-only memory (ROM)
- 512 bytes of random-access memory (RAM)
- 26 bytes of user-defined vectors
- 470 bytes of monitor ROM

### 2.3 Unimplemented Memory Locations

Accessing an unimplemented location can cause an illegal address reset if illegal address resets are enabled. In the memory map (**Figure 2-1**) and in register figures in this document, unimplemented locations are shaded.

## 2.4 Reserved Memory Locations

Accessing a reserved location can have unpredictable effects on MCU operation. In the [Figure 2-1](#) and in register figures in this document, reserved locations are marked with the word Reserved or with the letter R.

## 2.5 Input/Output (I/O) Section

Most of the control, status, and data registers are in the zero page area of \$0000–\$005F. Additional I/O registers have these addresses:

- \$FE00; SIM Break Status Register, SBSR
- \$FE01; SIM Reset Status Register, SRSR
- \$FE02; reserved
- \$FE03; SIM Break Flag Control Register, SBFCR
- \$FE04; Interrupt Status Register 1, INT1
- \$FE05; Interrupt Status Register 2, INT2
- \$FE06; reserved
- \$FE07; reserved
- \$FE08; reserved
- \$FE09; reserved
- \$FE0A; reserved
- \$FE0B; reserved
- \$FE0C; Break Address Register High, BRKH
- \$FE0D; Break Address Register Low, BRKL
- \$FE0E; Break Status and Control Register, BRKSCR

Data registers are shown in [Figure 2-2](#). [Table 2-1](#) is a list of vector locations.



\$0000	I/O Registers 96 Bytes
↓	
\$005F	Unimplemented 32 Bytes
↓	
\$0060	RAM 512 Bytes
↓	
\$007F	Unimplemented 39,296 Bytes
↓	
\$0080	User ROM 24,576 Bytes
↓	
\$027F	User ROM 512 Bytes
↓	
\$0280	SIM Break Status Register (SBSR)
↓	
\$07FF	SIM Reset Status Register (SRSR)
↓	
\$0800	Reserved
↓	
\$0803	SIM Break Flag Control Register (SBFCR)
↓	
\$0804	Interrupt Status Register 1 (INT1)
↓	
\$0805	Interrupt Status Register 2 (INT2)
↓	
\$0806	Reserved
↓	
\$0807	Reserved
↓	
\$0808	Reserved
↓	
\$0809	Reserved
↓	
\$080A	Reserved
↓	

**Figure 2-1. Memory Map**

\$FE0B	Reserved
\$FE0C	Break Address Register High (BRKH)
\$FE0D	Break Address Register Low (BRKL)
\$FE0E	Break Status and Control Register (BRKSCR)
\$FE0F	Reserved
\$FE10	Monitor ROM 470 Bytes
↓	
\$FFE5	User ROM Vectors 26 Bytes
\$FFE6	
↓	
\$FFFF	

Figure 2-1. Memory Map (Continued)

Addr.	Register Name	Bit 7	6	5	4	3	2	1	Bit 0		
\$0000	Port A Data Register (PTA)	Read:	PTA7	PTA6	PTA5	PTA4	PTA3	PTA2	PTA1	PTA0	
		Write:									
		Reset:	Unaffected by reset								
\$0001	Port B Data Register (PTB)	Read:	PTB7	PTB6	PTB5	PTB4	PTB3	PTB2	PTB1	PTB0	
		Write:									
		Reset:	Unaffected by reset								
\$0002	Port C Data Register (PTC)	Read:	0	0	PTC5	PTC4	PTC3	PTC2	PTC1	PTC0	
		Write:									
		Reset:	Unaffected by reset								
\$0003	Port D Data Register (PTD)	Read:	0	PTD6	PTD5	PTD4	PTD3	PTD2	PTD1	PTD0	
		Write:									
		Reset:	Unaffected by reset								
\$0004	Data Direction Register A (DDRA)	Read:	DDRA7	DDRA6	DDRA5	DDRA4	DDRA3	DDRA2	DDRA1	DDRA0	
		Write:									
		Reset:	0	0	0	0	0	0	0	0	
\$0005	Data Direction Register B (DDRB)	Read:	DDRB7	DDRB6	DDRB5	DDRB4	DDRB3	DDRB2	DDRB1	DDRB0	
		Write:									
		Reset:	0	0	0	0	0	0	0	0	
\$0006	Data Direction Register C (DDRC)	Read:	0	0	DDRC5	DDRC4	DDRC3	DDRC2	DDRC1	DDRC0	
		Write:									
		Reset:	0	0	0	0	0	0	0	0	
\$0007	Data Direction Register D (DDRD)	Read:	0	DDRD6	DDRD5	DDRD4	DDRD3	DDRD2	DDRD1	DDRD0	
		Write:									
		Reset:	0	0	0	0	0	0	0	0	
\$0008	Port E Data Register (PTE)	Read:	0	0	0	0	0	PTE2	PTE1	PTE0	
		Write:									
		Reset:	Unaffected by reset								
\$0009	Data Direction Register E (DDRE)	Read:	0	0	0	0	0	DDRE2	DDRE1	DDRE0	
		Write:									
		Reset:	0	0	0	0	0	0	0	0	

= Unimplemented
 R = Reserved

**Figure 2-2. Control, Status, and Data Registers (Sheet 1 of 12)**

Memory Map

Addr.	Register Name	Bit 7	6	5	4	3	2	1	Bit 0	
\$000A	TIM Status and Control Register (TSC)	Read:	TOF	TOIE	TSTOP	0	0	PS2	PS1	PS0
		Write:	0			TRST				
		Reset:	0	0	1	0	0	0	0	0
\$000B	Unimplemented	Read:								
		Write:								
		Reset:	0	0	0	0	0	0	0	0
\$000C	TIM Counter Register High (TCNTH)	Read:	Bit15	Bit14	Bit13	Bit12	Bit11	Bit10	Bit9	Bit8
		Write:								
		Reset:	0	0	0	0	0	0	0	0
\$000D	TIM Counter Register Low (TCNTL)	Read:	Bit7	Bit6	Bit5	Bit4	Bit3	Bit2	Bit1	Bit0
		Write:								
		Reset:	0	0	0	0	0	0	0	0
\$000E	TIM Counter Modulo Register High (TMODH)	Read:	Bit15	Bit14	Bit13	Bit12	Bit11	Bit10	Bit9	Bit8
		Write:								
		Reset:	1	1	1	1	1	1	1	1
\$000F	TIM Counter Modulo Register Low (TMDL)	Read:	Bit7	Bit6	Bit5	Bit4	Bit3	Bit2	Bit1	Bit0
		Write:								
		Reset:	1	1	1	1	1	1	1	1
\$0010	TIM Channel 0 Status and Control Register (TSC0)	Read:	CH0F	CH0IE	MS0B	MS0A	ELS0B	ELS0A	TOV0	CH0MAX
		Write:	0							
		Reset:	0	0	0	0	0	0	0	0
\$0011	TIM Channel 0 Register High (TCH0H)	Read:	Bit15	Bit14	Bit13	Bit12	Bit11	Bit10	Bit9	Bit8
		Write:								
		Reset:	Indeterminate after reset							
\$0012	TIM Channel 0 Register Low (TCH0L)	Read:	Bit7	Bit6	Bit5	Bit4	Bit3	Bit2	Bit1	Bit0
		Write:								
		Reset:	Indeterminate after reset							
\$0013	TIM Channel 1 Status and Control Register (TSC1)	Read:	CH1F	CH1IE	0	MS1A	ELS1B	ELS1A	TOV1	CH1MAX
		Write:	0							
		Reset:	0	0	0	0	0	0	0	0

= Unimplemented
  = Reserved

Figure 2-2. Control, Status, and Data Registers (Sheet 2 of 12)

Addr.	Register Name	Bit 7	6	5	4	3	2	1	Bit 0	
\$0014	TIM Channel 1 Register High (TCH1H)	Read:	Bit15	Bit14	Bit13	Bit12	Bit11	Bit10	Bit9	Bit8
		Write:								
		Reset:	Indeterminate after reset							
\$0015	TIM Channel 1 Register Low (TCH1L)	Read:	Bit7	Bit6	Bit5	Bit4	Bit3	Bit2	Bit1	Bit0
		Write:								
		Reset:	Indeterminate after reset							
\$0016	DDC Master Control Register (DMCR)	Read:	ALIF	NAKIF	BB	MAST	MRW	BR2	BR1	BR0
		Write:								
		Reset:	0	0	0	0	0	0	0	0
\$0017	DDC Address Register (DADR)	Read:	DAD7	DAD6	DAD5	DAD4	DAD3	DAD2	DAD1	EXTAD
		Write:								
		Reset:	1	0	1	0	0	0	0	0
\$0018	DDC Control Register (DCR)	Read:	DEN	DIEN	0	0	TXAK	SCLIEN	DDC1EN	0
		Write:								
		Reset:	0	0	0	0	0	0	0	0
\$0019	DDC Status Register (DSR)	Read:	RXIF	TXIF	MATCH	SRW	RXAK	SCLIF	TXBE	RXBF
		Write:	0	0				0		
		Reset:	0	0	0	0	1	0	1	0
\$001A	DDC Data Transmit Register (DDTR)	Read:	DTD7	DTD6	DTD5	DTD4	DTD3	DTD2	DTD1	DTD0
		Write:								
		Reset:	1	1	1	1	1	1	1	1
\$001B	DDC Data Receive Register (DDRR)	Read:	DRD7	DRD6	DRD5	DRD4	DRD3	DRD2	DRD1	DRD0
		Write:								
		Reset:	0	0	0	0	0	0	0	0
\$001C	DDC2 Address Register (D2ADR)	Read:	D2AD7	D2AD6	D2AD5	D2AD4	D2AD3	D2AD2	D2AD1	0
		Write:								
		Reset:	0	0	0	0	0	0	0	0
\$001D	Configuration Register 0 (CONFIG0)	Read:	HSYNCOE	VSYNCOE	SOGE	0	0	0	0	0
		Write:								
		Reset:	0	0	0	0	0	0	0	0

= Unimplemented     
 R = Reserved

Figure 2-2. Control, Status, and Data Registers (Sheet 3 of 12)

Memory Map

Addr.	Register Name	Bit 7	6	5	4	3	2	1	Bit 0		
\$001E	IRQ Status and Control Register (INTSCR)	Read:	0	0	0	0	IRQF	0	IMASK	MODE	
		Write:	R					ACK			
		Reset:	0	0	0	0	0	0	0	0	
\$001F	Configuration Register 1 (CONFIG1) <sup>†</sup>	Read:	0	0	0	0	SSREC	COPRS	STOP	COPD	
		Write:	R								
		Reset:	0	0	0	0	0	0	0	0	
† One-time writable register after each reset.											
\$0020	PWM0 Data Register (0PWM)	Read:	0PWM4	0PWM3	0PWM2	0PWM1	0PWM0	0BRM2	0BRM1	0BRM0	
		Write:	R								
		Reset:	0	0	0	0	0	0	0	0	
\$0021	PWM1 Data Register (1PWM)	Read:	1PWM4	1PWM3	1PWM2	1PWM1	1PWM0	1BRM2	1BRM1	1BRM0	
		Write:	R								
		Reset:	0	0	0	0	0	0	0	0	
\$0022	PWM2 Data Register (2PWM)	Read:	2PWM4	2PWM3	2PWM2	2PWM1	2PWM0	2BRM2	2BRM1	2BRM0	
		Write:	R								
		Reset:	0	0	0	0	0	0	0	0	
\$0023	PWM3 Data Register (3PWM)	Read:	3PWM4	3PWM3	3PWM2	3PWM1	3PWM0	3BRM2	3BRM1	3BRM0	
		Write:	R								
		Reset:	0	0	0	0	0	0	0	0	
\$0024	PWM4 Data Register (4PWM)	Read:	4PWM4	4PWM3	4PWM2	4PWM1	4PWM0	4BRM2	4BRM1	4BRM0	
		Write:	R								
		Reset:	0	0	0	0	0	0	0	0	
\$0025	PWM5 Data Register (5PWM)	Read:	5PWM4	5PWM3	5PWM2	5PWM1	5PWM0	5BRM2	5BRM1	5BRM0	
		Write:	R								
		Reset:	0	0	0	0	0	0	0	0	
\$0026	PWM6 Data Register (6PWM)	Read:	6PWM4	6PWM3	6PWM2	6PWM1	6PWM0	6BRM2	6BRM1	6BRM0	
		Write:	R								
		Reset:	0	0	0	0	0	0	0	0	
\$0027	PWM7 Data Register (7PWM)	Read:	7PWM4	7PWM3	7PWM2	7PWM1	7PWM0	7BRM2	7BRM1	7BRM0	
		Write:	R								
		Reset:	0	0	0	0	0	0	0	0	
			R = Unimplemented				R = Reserved				

Figure 2-2. Control, Status, and Data Registers (Sheet 4 of 12)

Addr.	Register Name	Bit 7	6	5	4	3	2	1	Bit 0	
\$0028	PWM Control Register 1 (PWMCr1)	Read:	PWM7E	PWM6E	PWM5E	PWM4E	PWM3E	PWM2E	PWM1E	PWM0E
		Write:								
		Reset:	0	0	0	0	0	0	0	0
\$0029	Reserved	Read:	R	R	R	R	R	R	R	R
		Write:								
		Reset:								
\$002A	Reserved	Read:	R	R	R	R	R	R	R	R
		Write:								
		Reset:								
\$002B	Reserved	Read:	R	R	R	R	R	R	R	R
		Write:								
		Reset:								
\$002C	Reserved	Read:	R	R	R	R	R	R	R	R
		Write:								
		Reset:								
\$002D	Reserved	Read:	R	R	R	R	R	R	R	R
		Write:								
		Reset:								
\$002E	Reserved	Read:	R	R	R	R	R	R	R	R
		Write:								
		Reset:								
\$002F	Reserved	Read:	R	R	R	R	R	R	R	R
		Write:								
		Reset:								
\$0030	Reserved	Read:	R	R	R	R	R	R	R	R
		Write:								
		Reset:								
\$0031	Reserved	Read:	R	R	R	R	R	R	R	R
		Write:								
		Reset:								

= Unimplemented     
 R = Reserved

**Figure 2-2. Control, Status, and Data Registers (Sheet 5 of 12)**

Memory Map

Freescale Semiconductor, Inc.

Addr.	Register Name	Bit 7	6	5	4	3	2	1	Bit 0	
\$0032	Reserved	Read:								
		Write:	R	R	R	R	R	R	R	R
		Reset:								
\$0033	Reserved	Read:								
		Write:	R	R	R	R	R	R	R	R
		Reset:								
\$0034	Reserved	Read:								
		Write:	R	R	R	R	R	R	R	R
		Reset:								
\$0035	Reserved	Read:								
		Write:	R	R	R	R	R	R	R	R
		Reset:								
\$0036	Reserved	Read:								
		Write:	R	R	R	R	R	R	R	R
		Reset:								
\$0037	Reserved	Read:								
		Write:	R	R	R	R	R	R	R	R
		Reset:								
\$0038	Reserved	Read:								
		Write:	R	R	R	R	R	R	R	R
		Reset:								
\$0039	Reserved	Read:								
		Write:	R	R	R	R	R	R	R	R
		Reset:								
\$003A	Reserved	Read:								
		Write:	R	R	R	R	R	R	R	R
		Reset:								
\$003B	Reserved	Read:								
		Write:	R	R	R	R	R	R	R	R
		Reset:								

= Unimplemented     
 R = Reserved

Figure 2-2. Control, Status, and Data Registers (Sheet 6 of 12)



Addr.	Register Name	Bit 7	6	5	4	3	2	1	Bit 0	
\$003C	Reserved	Read:								
		Write:	R	R	R	R	R	R	R	R
		Reset:								
\$003D	Reserved	Read:								
		Write:	R	R	R	R	R	R	R	R
		Reset:								
\$003E	Reserved	Read:								
		Write:	R	R	R	R	R	R	R	R
		Reset:								
\$003F	Reserved	Read:								
		Write:	R	R	R	R	R	R	R	R
		Reset:								
\$0040	Sync Processor Control and Status Register (SPCSR)	Read:	VSIE	VEDGE	VSIF	COMP	VINVO	HINVO	VPOL	HPOL
		Write:			0					
		Reset:	0	0	0	0	0	0	0	0
\$0041	Vertical Frequency High Register (VFHR)	Read:	VOF	0	0	VF12	VF11	VF10	VF9	VF8
		Write:		CPW1	CPW0					
		Reset:	0	0	0	0	0	0	0	0
\$0042	Vertical Frequency Low Register (VFLR)	Read:	VF7	VF6	VF5	VF4	VF3	VF2	VF1	VF0
		Write:								
		Reset:	0	0	0	0	0	0	0	0
\$0043	Hsync Frequency High Register (HFHR)	Read:	HFH7	HFH6	HFH5	HFH4	HFH3	HFH2	HFH1	HFH0
		Write:								
		Reset:	0	0	0	0	0	0	0	0
\$0044	Hsync Frequency Low Register (HFLR)	Read:	HOVER	0	0	HFL4	HFL3	HFL2	HFL1	HFL0
		Write:								
		Reset:	0	0	0	0	0	0	0	0
\$0045	Sync Processor I/O Control Register (SPIOCR)	Read:	VSYNCS	HSYNCS	COINV	R	SOGSEL	CLAMPOE	BPOR	SOUT
		Write:								
		Reset:	0	0	0	0	0	0	0	0

= Unimplemented     
 R = Reserved

Figure 2-2. Control, Status, and Data Registers (Sheet 7 of 12)

Memory Map

Freescale Semiconductor, Inc.

Addr.	Register Name	Bit 7	6	5	4	3	2	1	Bit 0	
\$0046	Sync Processor Control Register 1 (SPCR1)	Read:	LVSIE	LVSIF	HPS1	HPS0	R	R	ATPOL	FSHF
		Write:		0						
		Reset:	0	0	0	0	0	0	0	0
\$0047	H&V Sync Output Control Register (HVOCR)	Read:	R	0	0	0	0	HVOCR2	HVOCR1	HVOCR0
		Write:								
		Reset:	0	0	0	0	0	0	0	0
\$0048	Unimplemented	Read:								
		Write:								
		Reset:								
\$0049	Port D Configuration Register (PDCR)	Read:	0	0	0	CLAMPE	DDCSCLE	DDCDATE	0	0
		Write:								
		Reset:	0	0	0	0	0	0	0	0
\$004A	Reserved	Read:	R	R	R	R	R	R	R	R
		Write:								
		Reset:								
\$004B	Reserved	Read:	R	R	R	R	R	R	R	R
		Write:								
		Reset:								
\$004C	Reserved	Read:	R	R	R	R	R	R	R	R
		Write:								
		Reset:								
\$004D	Reserved	Read:	R	R	R	R	R	R	R	R
		Write:								
		Reset:								
\$004E	Reserved	Read:	R	R	R	R	R	R	R	R
		Write:								
		Reset:								
\$004F	Reserved	Read:	R	R	R	R	R	R	R	R
		Write:								
		Reset:								

= Unimplemented     
 R = Reserved

Figure 2-2. Control, Status, and Data Registers (Sheet 8 of 12)

Addr.	Register Name	Bit 7	6	5	4	3	2	1	Bit 0
\$0050	Unimplemented	Read: [Grey Box] [Grey Box] [Grey Box] [Grey Box] [Grey Box] [Grey Box] [Grey Box] [Grey Box] Write: [Grey Box] [Grey Box] [Grey Box] [Grey Box] [Grey Box] [Grey Box] [Grey Box] [Grey Box] Reset:							
\$0051	PWM8 Data Register (8PWM)	8PWM4	8PWM3	8PWM2	8PWM1	8PWM0	8BRM2	8BRM1	8BRM0
		Reset: 0 0 0 0 0 0 0 0							
\$0052	PWM9 Data Register (9PWM)	9PWM4	9PWM3	9PWM2	9PWM1	9PWM0	9BRM2	9BRM1	9BRM0
		Reset: 0 0 0 0 0 0 0 0							
\$0053	PWM10 Data Register (10PWM)	10PWM4	10PWM3	10PWM2	10PWM1	10PWM0	10BRM2	10BRM1	10BRM0
		Reset: 0 0 0 0 0 0 0 0							
\$0054	PWM11 Data Register (11PWM)	11PWM4	11PWM3	11PWM2	11PWM1	11PWM0	11BRM2	11BRM1	11BRM0
		Reset: 0 0 0 0 0 0 0 0							
\$0055	PWM12 Data Register (12PWM)	12PWM4	12PWM3	12PWM2	12PWM1	12PWM0	12BRM2	12BRM1	12BRM0
		Reset: 0 0 0 0 0 0 0 0							
\$0056	PWM13 Data Register (13PWM)	13PWM4	13PWM3	13PWM2	13PWM1	13PWM0	13BRM2	13BRM1	13BRM0
		Reset: 0 0 0 0 0 0 0 0							
\$0057	PWM14 Data Register (14PWM)	14PWM4	PWM3	14PWM2	14PWM1	14PWM0	14BRM2	14BRM1	14BRM0
		Reset: 0 0 0 0 0 0 0 0							
\$0058	PWM15 Data Register (15PWM)	15PWM4	15PWM3	15PWM2	15PWM1	15PWM0	15BRM2	15BRM1	15BRM0
		Reset: 0 0 0 0 0 0 0 0							
\$0059	PWM Control Register 2 (PWMC2)	PWM15E	PWM14E	PWM13E	PWM12E	PWM11E	PWM10E	PWM9E	PWM8E
		Reset: 0 0 0 0 0 0 0 0							

= Unimplemented     
 R = Reserved

**Figure 2-2. Control, Status, and Data Registers (Sheet 9 of 12)**

Memory Map

Addr.	Register Name	Bit 7	6	5	4	3	2	1	Bit 0	
\$005A	Unimplemented	Read:								
		Write:								
		Reset:								
\$005B	Unimplemented	Read:								
		Write:								
		Reset:								
\$005C	Unimplemented	Read:								
		Write:								
		Reset:								
\$005D	ADC Status and Control Register (ADSCR)	Read:	COCO	AIEN	ADCO	ADCH4	ADCH3	ADCH2	ADCH1	ADCH0
		Write:								
		Reset:	0	0	0	1	1	1	1	1
\$005E	ADC Data Register (ADR)	Read:	AD7	AD6	AD5	AD4	AD3	AD2	AD1	AD0
		Write:								
		Reset:	Unaffected after Reset							
\$005F	ADC Input Clock Register (ADICLK)	Read:	ADIV2	ADIV1	ADIV0	0	0	0	0	0
		Write:								
		Reset:	0	0	0	0	0	0	0	0
\$FE00	SIM Break Status Register (SBSR)	Read:	R	R	R	R	R	SBSW	R	
		Write:						Note		
		Reset:	0	0	0	0	0	0	0	0
Note: Writing a logic 0 clears SBSW.										
\$FE01	SIM Reset Status Register (SRSR)	Read:	POR	PIN	COP	ILOP	ILAD	0	0	0
		Write:								
		POR:	1	0	0	0	0	0	0	0
\$FE02	Reserved	Read:	R	R	R	R	R	R	R	
		Write:								
		Reset:	0	0	0	0	0	0	0	0
			= Unimplemented					= Reserved		

Figure 2-2. Control, Status, and Data Registers (Sheet 10 of 12)

Addr.	Register Name	Bit 7	6	5	4	3	2	1	Bit 0		
\$FE03	SIM Break Flag Control Register (SBFCR)	Read:									
		Write:	BCFE	R	R	R	R	R	R	R	
		Reset:	0								
\$FE04	Interrupt Status Register 1 (INT1)	Read:	IF6	IF5	IF4	IF3	IF2	IF1	0	0	
		Write:	R	R	R	R	R	R	R	R	R
		Reset:	0	0	0	0	0	0	0	0	0
\$FE05	Interrupt Status Register 2 (INT2)	Read:	0	0	0	0	IF10	IF9	IF8	IF7	
		Write:	R	R	R	R	R	R	R	R	R
		Reset:	0	0	0	0	0	0	0	0	0
\$FE06	Reserved	Read:									
		Write:	R	R	R	R	R	R	R	R	
		Reset:	0	0	0	0	0	0	0	0	
\$FE07	Reserved	Read:									
		Write:	R	R	R	R	R	R	R	R	
		Reset:	0	0	0	0	0	0	0	0	
\$FE08	Reserved	Read:									
		Write:	R	R	R	R	R	R	R	R	
		Reset:	0	0	0	0	0	0	0	0	
\$FE09	Reserved	Read:									
		Write:	R	R	R	R	R	R	R	R	
		Reset:	0	0	0	0	0	0	0	0	
\$FE0A	Reserved	Read:									
		Write:	R	R	R	R	R	R	R	R	
		Reset:	0	0	0	0	0	0	0	0	
\$FE0B	Reserved	Read:									
		Write:	R	R	R	R	R	R	R	R	
		Reset:	0	0	0	0	0	0	0	0	
\$FE0C	Break Address High Register (BRKH)	Read:									
		Write:	Bit15	Bit14	Bit13	Bit12	Bit11	Bit10	Bit9	Bit8	
		Reset:	0	0	0	0	0	0	0	0	

= Unimplemented     
 R = Reserved

Figure 2-2. Control, Status, and Data Registers (Sheet 11 of 12)

Memory Map

Addr.	Register Name	Bit 7	6	5	4	3	2	1	Bit 0	
\$FE0D	Break Address low Register (BRKL)	Read:	Bit7	Bit6	Bit5	Bit4	Bit3	Bit2	Bit1	Bit0
		Write:								
		Reset:	0	0	0	0	0	0	0	0
\$FE0E	Break Status and Control Register (BRKSCR)	Read:	BRKE	BRKA	0	0	0	0	0	0
		Write:								
		Reset:	0	0	0	0	0	0	0	0
\$FFFF	COP Control Register (COPCTL)	Read:	Low byte of reset vector							
		Write:	Writing clears COP counter (any value)							
		Reset:	Unaffected by reset							

= Unimplemented
  = Reserved

Figure 2-2. Control, Status, and Data Registers (Sheet 12 of 12)

Freescale Semiconductor, Inc.

**Table 2-1. Vector Addresses**

VectorPriority	Vector	Address	Vector
Lowest  Highest	—	\$FFE6	Reserved
		\$FFE7	Reserved
	IF10	\$FFE8	ADC Interrupt Vector (High)
		\$FFE9	ADC Interrupt Vector (Low)
	IF9	\$FFEA	Reserved
		\$FFEB	Reserved
	IF8	\$FFEC	Sync Processor Vector (High)
		\$FFED	Sync Processor Vector (Low)
	IF7	\$FFEE	TIM Overflow Vector (High)
		\$FFEF	TIM Overflow Vector (Low)
	IF6	\$FFF0	TIM Channel 1 Vector (High)
		\$FFF1	TIM Channel 1 Vector (Low)
	IF5	\$FFF2	TIM Channel 0 Vector (High)
		\$FFF3	TIM Channel 0 Vector (Low)
	IF4	\$FFF4	Reserved
		\$FFF5	Reserved
	IF3	\$FFF6	DDC12AB Vector (High)
		\$FFF7	DDC12AB Vector (Low)
	IF2	\$FFF8	Reserved
		\$FFF9	Reserved
IF1	\$FFFA	$\overline{\text{IRQ}}$ Vector (High)	
	\$FFFB	$\overline{\text{IRQ}}$ Vector (Low)	
—	\$FFFC	SWI Vector (High)	
	\$FFFD	SWI Vector (Low)	
—	\$FFFE	Reset Vector (High)	
	\$FFFF	Reset Vector (Low)	





## Section 3. Random-Access Memory (RAM)

### 3.1 Contents

3.2	Introduction . . . . .	49
3.3	Functional Description . . . . .	49

### 3.2 Introduction

This section describes the 512 bytes of RAM (random-access memory).

### 3.3 Functional Description

Addresses \$0080 through \$027F are RAM locations. The location of the stack RAM is programmable. The 16-bit stack pointer allows the stack to be anywhere in the 64-Kbyte memory space.

**NOTE:** *For correct operation, the stack pointer must point only to RAM locations.*

Within page zero are 128 bytes of RAM. Because the location of the stack RAM is programmable, all page zero RAM locations can be used for I/O control and user data or code. When the stack pointer is moved from its reset location at \$00FF out of page zero, direct addressing mode instructions can efficiently access all page zero RAM locations. Page zero RAM, therefore, provides ideal locations for frequently accessed global variables.

Before processing an interrupt, the CPU uses five bytes of the stack to save the contents of the CPU registers.

**NOTE:** *For M6805 compatibility, the H register is not stacked.*

During a subroutine call, the CPU uses two bytes of the stack to store the return address. The stack pointer decrements during pushes and increments during pulls.

**NOTE:** *Be careful when using nested subroutines. The CPU may overwrite data in the RAM during a subroutine or during the interrupt stacking operation.*

## Section 4. Read-Only Memory (ROM)

### 4.1 Contents

4.2	Introduction . . . . .	51
4.3	Functional Description . . . . .	51

### 4.2 Introduction

This section describes the 25,088 bytes of ROM (read-only memory).

### 4.3 Functional Description

These addresses are user ROM locations:

\$9C00 – \$FBFF (24,576 bytes)

\$FC00 – \$FDFF (512 bytes)

\$FFE6 – \$FFFF (These locations are reserved for user-defined interrupt and reset vectors.)

**NOTE:** *A security feature prevents viewing of the ROM contents.<sup>1</sup>*

---

1. No security feature is absolutely secure. However, Motorola's strategy is to make reading or copying the ROM contents difficult for unauthorized users.



## Section 5. Configuration Register (CONFIG)

### 5.1 Contents

5.2	Introduction . . . . .	53
5.3	Configuration Register 0 . . . . .	54
5.4	Configuration Register 1 . . . . .	55

### 5.2 Introduction

This section describes the configuration registers, CONFIG0 and CONFIG1. The configuration registers enable or disable these options:

- Sync processor HSYNCO output pin
- Sync processor VSYNCO output pin
- Sync processor SOG input pin
- Stop mode recovery time (32 OSCXCLK cycles or 4096 OSCXCLK cycles)
- COP timeout period ( $2^{18} - 2^4$  or  $2^{13} - 2^4$  OSCXCLK cycles)
- STOP instruction
- Computer operating properly module (COP)

Configuration Register (CONFIG)

5.3 Configuration Register 0

The CONFIG0 register is used to select the I/O pins for sync processor output functions.

Address: \$001D

	Bit 7	6	5	4	3	2	1	Bit 0
Read:	HSYNCOE	VSYNCOE	SOGE	0	0	0	0	0
Write:								
Reset:	0	0	0	0	0	0	0	0

= Unimplemented

Figure 5-1. Configuration Register 0 (CONFIG0)

HSYNCOE — VSYNCO Enable

This bit is set to configure the PTE1/HSYNCO pin for HSYNCO output function. Reset clears this bit.

- 1 = PTE1/HSYNCO pin configured as HSYNCO pin
- 0 = PTE1/HSYNCO pin configured as standard I/O pin

VSYNCOE — VSYNCO Enable

This bit is set to configure the PTE2/VSYNCO pin for VSYNCO output function. Reset clears this bit.

- 1 = PTE2/VSYNCO pin configured as VSYNCO pin
- 0 = PTE2/VSYNCO pin configured as standard I/O pin

SOGE — SOG Enable

This bit is set to configure the PTE0/SOG/TCH0 pin for SOG output function. Reset clears this bit.

- 1 = PTE0/SOG/TCH0 pin configured as SOG pin
- 0 = PTE0/SOG/TCH0 pin configured as standard I/O or TCH0 pin.  
TCH0 function is configured by ELS0B and ELS0A bits in TSC0 (bits 3 and 2 in \$0010). (See [10.10.4 TIM Channel Status and Control Registers \(TSC0:TSC1\)](#).)

## 5.4 Configuration Register 1

The CONFIG1 register is used in the initialization of various MCU options. It can only be written once after each reset. All of the CONFIG1 register bits are cleared during reset. Since the various options affect the operation of the MCU, it is recommended that the CONFIG1 register be written immediately after reset.



**Figure 5-2. Configuration Register 1 (CONFIG1)**

### SSREC — Short Stop Recovery Bit

SSREC enables the CPU to exit stop mode with a delay of 32 OSCXCLK cycles instead of a 4096-OSCXCLK cycle delay.

1 = Stop mode recovery after 32 OSCXCLK cycles

0 = Stop mode recovery after 4096 OSCXCLK cycles

**NOTE:** *Exiting stop mode by pulling reset will result in the long stop recovery.*

*If using an external crystal oscillator, do not set the SSREC bit.*

### COPRS — COP Rate Select Bit

COPRS selects the COP timeout period. Reset clears COPRS. (See [Section 17. Computer Operating Properly \(COP\)](#).)

1 = COP timeout period =  $2^{13} - 2^4$  CGMXCLK cycles

0 = COP timeout period =  $2^{18} - 2^4$  CGMXCLK cycles

### STOP — STOP Instruction Enable Bit

STOP enables the STOP instruction.

1 = STOP instruction enabled

0 = STOP instruction treated as illegal opcode

COPD — COP Disable Bit

COPD disables the COP module. (See [Section 17. Computer Operating Properly \(COP\)](#).)

1 = COP module disabled

0 = COP module enabled



## Section 6. Central Processor Unit (CPU)

### 6.1 Contents

6.2	Introduction . . . . .	57
6.3	Features . . . . .	58
6.4	CPU Registers . . . . .	58
6.4.1	Accumulator . . . . .	59
6.4.2	Index Register . . . . .	60
6.4.3	Stack Pointer . . . . .	60
6.4.4	Program Counter . . . . .	61
6.4.5	Condition Code Register . . . . .	61
6.5	Arithmetic/Logic Unit (ALU) . . . . .	64
6.6	Low-Power Modes . . . . .	64
6.6.1	Wait Mode . . . . .	64
6.6.2	Stop Mode . . . . .	65
6.7	CPU During Break Interrupts . . . . .	65
6.8	Instruction Set Summary . . . . .	65
6.9	Opcode Map . . . . .	65

### 6.2 Introduction

The M68HC08 CPU (central processor unit) is an enhanced and fully object-code-compatible version of the M68HC05 CPU. The *CPU08 Reference Manual* (Motorola document order number CPU08RM/AD) contains a description of the CPU instruction set, addressing modes, and architecture.

### 6.3 Features

- Object code fully upward-compatible with M68HC05 Family
- 16-bit stack pointer with stack manipulation instructions
- 16-bit index register with x-register manipulation instructions
- 6-MHz CPU internal bus frequency
- 64-Kbyte program/data memory space
- 16 addressing modes
- Memory-to-memory data moves without using accumulator
- Fast 8-bit by 8-bit multiply and 16-bit by 8-bit divide instructions
- Enhanced binary-coded decimal (BCD) data handling
- Modular architecture with expandable internal bus definition for extension of addressing range beyond 64 Kbytes
- Low-power stop and wait modes

### 6.4 CPU Registers

**Figure 6-1** shows the five CPU registers. CPU registers are not part of the memory map.

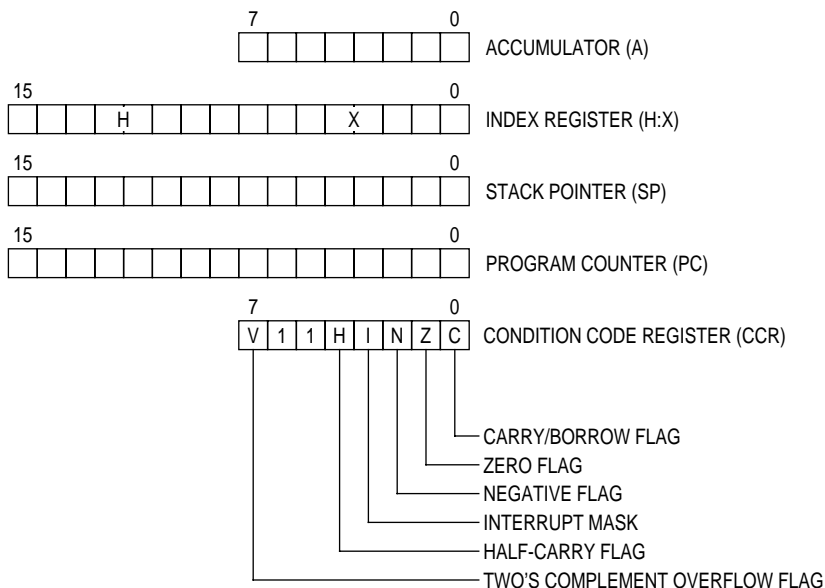

**Figure 6-1. CPU Registers**

**6.4.1 Accumulator**

The accumulator is a general-purpose 8-bit register. The CPU uses the accumulator to hold operands and the results of arithmetic/logic operations.

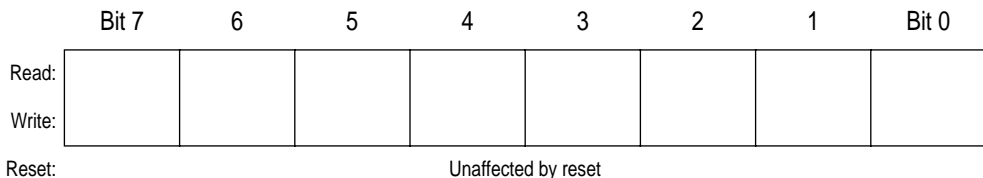

**Figure 6-2. Accumulator (A)**

### 6.4.2 Index Register

The 16-bit index register allows indexed addressing of a 64-Kbyte memory space. H is the upper byte of the index register, and X is the lower byte. H:X is the concatenated 16-bit index register.

In the indexed addressing modes, the CPU uses the contents of the index register to determine the conditional address of the operand.

The index register can serve also as a temporary data storage location.

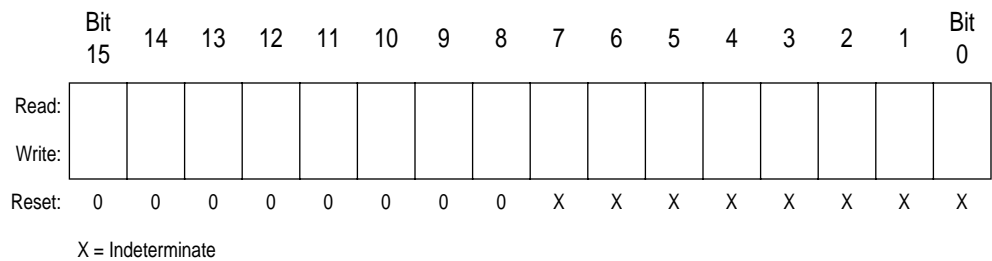
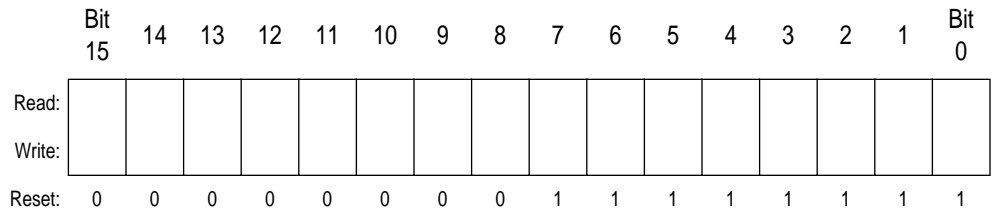

Figure 6-3. Index Register (H:X)

### 6.4.3 Stack Pointer

The stack pointer is a 16-bit register that contains the address of the next location on the stack. During a reset, the stack pointer is preset to \$00FF. The reset stack pointer (RSP) instruction sets the least significant byte to \$FF and does not affect the most significant byte. The stack pointer decrements as data is pushed onto the stack and increments as data is pulled from the stack.

In the stack pointer 8-bit offset and 16-bit offset addressing modes, the stack pointer can function as an index register to access data on the stack. The CPU uses the contents of the stack pointer to determine the conditional address of the operand.



**Figure 6-4. Stack Pointer (SP)**

**NOTE:** *The location of the stack is arbitrary and may be relocated anywhere in RAM. Moving the SP out of page 0 (\$0000 to \$00FF) frees direct address (page 0) space. For correct operation, the stack pointer must point only to RAM locations.*

#### 6.4.4 Program Counter

The program counter is a 16-bit register that contains the address of the next instruction or operand to be fetched.

Normally, the program counter automatically increments to the next sequential memory location every time an instruction or operand is fetched. Jump, branch, and interrupt operations load the program counter with an address other than that of the next sequential location.

During reset, the program counter is loaded with the reset vector address located at \$FFFE and \$FFFF. The vector address is the address of the first instruction to be executed after exiting the reset state.

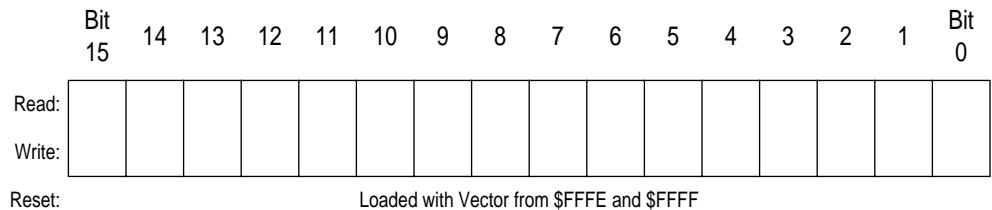

**Figure 6-5. Program Counter (PC)**

#### 6.4.5 Condition Code Register

The 8-bit condition code register contains the interrupt mask and five flags that indicate the results of the instruction just executed. Bits 6 and

5 are set permanently to logic 1. The following paragraphs describe the functions of the condition code register.

	Bit 7	6	5	4	3	2	1	Bit 0
Read:	V	1	1	H	I	N	Z	C
Write:								
Reset:	X	1	1	X	1	X	X	X

X = Indeterminate

**Figure 6-6. Condition Code Register (CCR)**

**V — Overflow Flag**

The CPU sets the overflow flag when a two's complement overflow occurs. The signed branch instructions BGT, BGE, BLE, and BLT use the overflow flag.

- 1 = Overflow
- 0 = No overflow

**H — Half-Carry Flag**

The CPU sets the half-carry flag when a carry occurs between accumulator bits 3 and 4 during an add-without-carry (ADD) or add-with-carry (ADC) operation. The half-carry flag is required for binary-coded decimal (BCD) arithmetic operations. The DAA instruction uses the states of the H and C flags to determine the appropriate correction factor.

- 1 = Carry between bits 3 and 4
- 0 = No carry between bits 3 and 4

## I — Interrupt Mask

When the interrupt mask is set, all maskable CPU interrupts are disabled. CPU interrupts are enabled when the interrupt mask is cleared. When a CPU interrupt occurs, the interrupt mask is set automatically after the CPU registers are saved on the stack, but before the interrupt vector is fetched.

1 = Interrupts disabled

0 = Interrupts enabled

**NOTE:** *To maintain M6805 Family compatibility, the upper byte of the index register (H) is not stacked automatically. If the interrupt service routine modifies H, then the user must stack and unstack H using the PSHH and PULH instructions.*

After the I bit is cleared, the highest-priority interrupt request is serviced first.

A return-from-interrupt (RTI) instruction pulls the CPU registers from the stack and restores the interrupt mask from the stack. After any reset, the interrupt mask is set and can be cleared only by the clear interrupt mask software instruction (CLI).

## N — Negative flag

The CPU sets the negative flag when an arithmetic operation, logic operation, or data manipulation produces a negative result, setting bit 7 of the result.

1 = Negative result

0 = Non-negative result

## Z — Zero flag

The CPU sets the zero flag when an arithmetic operation, logic operation, or data manipulation produces a result of \$00.

1 = Zero result

0 = Non-zero result

**C — Carry/Borrow Flag**

The CPU sets the carry/borrow flag when an addition operation produces a carry out of bit 7 of the accumulator or when a subtraction operation requires a borrow. Some instructions — such as bit test and branch, shift, and rotate — also clear or set the carry/borrow flag.

1 = Carry out of bit 7

0 = No carry out of bit 7

**6.5 Arithmetic/Logic Unit (ALU)**

The ALU performs the arithmetic and logic operations defined by the instruction set.

Refer to the *CPU08 Reference Manual* (Motorola document order number CPU08RM/AD) for a description of the instructions and addressing modes and more detail about the architecture of the CPU.

**6.6 Low-Power Modes**

The WAIT and STOP instructions put the MCU in low power-consumption standby modes.

**6.6.1 Wait Mode**

The WAIT instruction:

- Clears the interrupt mask (I bit) in the condition code register, enabling interrupts. After exit from wait mode by interrupt, the I bit remains clear. After exit by reset, the I bit is set.
- Disables the CPU clock



## 6.6.2 Stop Mode

The STOP instruction:

- Clears the interrupt mask (I bit) in the condition code register, enabling external interrupts. After exit from stop mode by external interrupt, the I bit remains clear. After exit by reset, the I bit is set.
- Disables the CPU clock

After exiting stop mode, the CPU clock begins running after the oscillator stabilization delay.

## 6.7 CPU During Break Interrupts

If a break module is present on the MCU, the CPU starts a break interrupt by:

- Loading the instruction register with the SWI instruction
- Loading the program counter with \$FFFC:\$FFFD or with \$FEFC:\$FEFD in monitor mode

The break interrupt begins after completion of the CPU instruction in progress. If the break address register match occurs on the last cycle of a CPU instruction, the break interrupt begins immediately.

A return-from-interrupt instruction (RTI) in the break routine ends the break interrupt and returns the MCU to normal operation if the break interrupt has been deasserted.

## 6.8 Instruction Set Summary

## 6.9 Opcode Map

See [Table 6-2](#).

Table 6-1. Instruction Set Summary

Source Form	Operation	Description	Effect on CCR						Address Mode	Opcode	Operand	Cycles
			V	H	I	N	Z	C				
ADC #opr ADC opr ADC opr ADC opr,X ADC opr,X ADC ,X ADC opr,SP ADC opr,SP	Add with Carry	$A \leftarrow (A) + (M) + (C)$	↑	↑	-	↑	↑	↑	IMM DIR EXT IX2 IX1 IX SP1 SP2	A9 B9 C9 D9 E9 F9 9EE9 9ED9	ii dd hh ll ee ff ff ff ff ff ff ff	2 3 4 4 3 2 4 5
ADD #opr ADD opr ADD opr ADD opr,X ADD opr,X ADD ,X ADD opr,SP ADD opr,SP	Add without Carry	$A \leftarrow (A) + (M)$	↑	↑	-	↑	↑	↑	IMM DIR EXT IX2 IX1 IX SP1 SP2	AB BB CB DB EB FB 9EEB 9EDB	ii dd hh ll ee ff ff ff ff ff	2 3 4 4 3 2 4 5
AIS #opr	Add Immediate Value (Signed) to SP	$SP \leftarrow (SP) + (16 \ll M)$	-	-	-	-	-	-	IMM	A7	ii	2
AIX #opr	Add Immediate Value (Signed) to H:X	$H:X \leftarrow (H:X) + (16 \ll M)$	-	-	-	-	-	-	IMM	AF	ii	2
AND #opr AND opr AND opr AND opr,X AND opr,X AND ,X AND opr,SP AND opr,SP	Logical AND	$A \leftarrow (A) \& (M)$	0	-	-	↑	↑	-	IMM DIR EXT IX2 IX1 IX SP1 SP2	A4 B4 C4 D4 E4 F4 9EE4 9ED4	ii dd hh ll ee ff ff ff ff ff	2 3 4 4 3 2 4 5
ASL opr ASLA ASLX ASL opr,X ASL ,X ASL opr,SP	Arithmetic Shift Left (Same as LSL)		↑	-	-	↑	↑	↑	DIR INH INH IX1 IX SP1	38 48 58 68 78 9E68	dd ff ff	4 1 1 4 3 5
ASR opr ASRA ASRX ASR opr,X ASR opr,X ASR opr,SP	Arithmetic Shift Right		↑	-	-	↑	↑	↑	DIR INH INH IX1 IX SP1	37 47 57 67 77 9E67	dd ff ff ff	4 1 1 4 3 5
BCC rel	Branch if Carry Bit Clear	$PC \leftarrow (PC) + 2 + rel \text{ ? } (C) = 0$	-	-	-	-	-	-	REL	24	rr	3
BCLR n, opr	Clear Bit n in M	$M_n \leftarrow 0$	-	-	-	-	-	-	DIR (b0) DIR (b1) DIR (b2) DIR (b3) DIR (b4) DIR (b5) DIR (b6) DIR (b7)	11 13 15 17 19 1B 1D 1F	dd dd dd dd dd dd dd dd	4 4 4 4 4 4 4 4

Table 6-1. Instruction Set Summary (Continued)

Source Form	Operation	Description	Effect on CCR						Address Mode	Opcode	Operand	Cycles
			V	H	I	N	Z	C				
BCS <i>rel</i>	Branch if Carry Bit Set (Same as BLO)	$PC \leftarrow (PC) + 2 + rel ? (C) = 1$	-	-	-	-	-	-	REL	25	rr	3
BEQ <i>rel</i>	Branch if Equal	$PC \leftarrow (PC) + 2 + rel ? (Z) = 1$	-	-	-	-	-	-	REL	27	rr	3
BGE <i>opr</i>	Branch if Greater Than or Equal To (Signed Operands)	$PC \leftarrow (PC) + 2 + rel ? (N \oplus V) = 0$	-	-	-	-	-	-	REL	90	rr	3
BGT <i>opr</i>	Branch if Greater Than (Signed Operands)	$PC \leftarrow (PC) + 2 + rel ? (Z)   (N \oplus V) = 0$	-	-	-	-	-	-	REL	92	rr	3
BHCC <i>rel</i>	Branch if Half Carry Bit Clear	$PC \leftarrow (PC) + 2 + rel ? (H) = 0$	-	-	-	-	-	-	REL	28	rr	3
BHCS <i>rel</i>	Branch if Half Carry Bit Set	$PC \leftarrow (PC) + 2 + rel ? (H) = 1$	-	-	-	-	-	-	REL	29	rr	3
BHI <i>rel</i>	Branch if Higher	$PC \leftarrow (PC) + 2 + rel ? (C)   (Z) = 0$	-	-	-	-	-	-	REL	22	rr	3
BHS <i>rel</i>	Branch if Higher or Same (Same as BCC)	$PC \leftarrow (PC) + 2 + rel ? (C) = 0$	-	-	-	-	-	-	REL	24	rr	3
BIH <i>rel</i>	Branch if IRQ Pin High	$PC \leftarrow (PC) + 2 + rel ? \overline{IRQ} = 1$	-	-	-	-	-	-	REL	2F	rr	3
BIL <i>rel</i>	Branch if IRQ Pin Low	$PC \leftarrow (PC) + 2 + rel ? \overline{IRQ} = 0$	-	-	-	-	-	-	REL	2E	rr	3
BIT # <i>opr</i> BIT <i>opr</i> BIT <i>opr</i> BIT <i>opr</i> ,X BIT <i>opr</i> ,X BIT ,X BIT <i>opr</i> ,SP BIT <i>opr</i> ,SP	Bit Test	(A) & (M)	0	-	-	↑	↑	-	IMM DIR EXT IX2 IX1 IX SP1 SP2	A5 B5 C5 D5 E5 F5 9EE5 9ED5	ii dd hh ll ee ff ff ff ee ff	2 3 4 4 3 2 4 5
BLE <i>opr</i>	Branch if Less Than or Equal To (Signed Operands)	$PC \leftarrow (PC) + 2 + rel ? (Z)   (N \oplus V) = 1$	-	-	-	-	-	-	REL	93	rr	3
BLO <i>rel</i>	Branch if Lower (Same as BCS)	$PC \leftarrow (PC) + 2 + rel ? (C) = 1$	-	-	-	-	-	-	REL	25	rr	3
BLS <i>rel</i>	Branch if Lower or Same	$PC \leftarrow (PC) + 2 + rel ? (C)   (Z) = 1$	-	-	-	-	-	-	REL	23	rr	3
BLT <i>opr</i>	Branch if Less Than (Signed Operands)	$PC \leftarrow (PC) + 2 + rel ? (N \oplus V) = 1$	-	-	-	-	-	-	REL	91	rr	3
BMC <i>rel</i>	Branch if Interrupt Mask Clear	$PC \leftarrow (PC) + 2 + rel ? (I) = 0$	-	-	-	-	-	-	REL	2C	rr	3
BMI <i>rel</i>	Branch if Minus	$PC \leftarrow (PC) + 2 + rel ? (N) = 1$	-	-	-	-	-	-	REL	2B	rr	3
BMS <i>rel</i>	Branch if Interrupt Mask Set	$PC \leftarrow (PC) + 2 + rel ? (I) = 1$	-	-	-	-	-	-	REL	2D	rr	3
BNE <i>rel</i>	Branch if Not Equal	$PC \leftarrow (PC) + 2 + rel ? (Z) = 0$	-	-	-	-	-	-	REL	26	rr	3
BPL <i>rel</i>	Branch if Plus	$PC \leftarrow (PC) + 2 + rel ? (N) = 0$	-	-	-	-	-	-	REL	2A	rr	3
BRA <i>rel</i>	Branch Always	$PC \leftarrow (PC) + 2 + rel$	-	-	-	-	-	-	REL	20	rr	3

Table 6-1. Instruction Set Summary (Continued)

Source Form	Operation	Description	Effect on CCR						Address Mode	Opcode	Operand	Cycles			
			V	H	I	N	Z	C							
BRCLR <i>n,opr,rel</i>	Branch if Bit <i>n</i> in M Clear	$PC \leftarrow (PC) + 3 + rel ? (Mn) = 0$						↓	DIR (b0)	01	dd rr	5			
										DIR (b1)	03	dd rr	5		
											DIR (b2)	05	dd rr	5	
											DIR (b3)	07	dd rr	5	
											DIR (b4)	09	dd rr	5	
											DIR (b5)	0B	dd rr	5	
											DIR (b6)	0D	dd rr	5	
											DIR (b7)	0F	dd rr	5	
BRN <i>rel</i>	Branch Never	$PC \leftarrow (PC) + 2$	-	-	-	-	-	-	REL	21	rr	3			
BRSET <i>n,opr,rel</i>	Branch if Bit <i>n</i> in M Set	$PC \leftarrow (PC) + 3 + rel ? (Mn) = 1$						↑	DIR (b0)	00	dd rr	5			
										DIR (b1)	02	dd rr	5		
											DIR (b2)	04	dd rr	5	
											DIR (b3)	06	dd rr	5	
											DIR (b4)	08	dd rr	5	
											DIR (b5)	0A	dd rr	5	
											DIR (b6)	0C	dd rr	5	
											DIR (b7)	0E	dd rr	5	
BSET <i>n,opr</i>	Set Bit <i>n</i> in M	$Mn \leftarrow 1$							DIR (b0)	10	dd	4			
										DIR (b1)	12	dd	4		
											DIR (b2)	14	dd	4	
											DIR (b3)	16	dd	4	
											DIR (b4)	18	dd	4	
											DIR (b5)	1A	dd	4	
											DIR (b6)	1C	dd	4	
											DIR (b7)	1E	dd	4	
BSR <i>rel</i>	Branch to Subroutine	$PC \leftarrow (PC) + 2$ ; push (PCL) $SP \leftarrow (SP) - 1$ ; push (PCH) $SP \leftarrow (SP) - 1$ $PC \leftarrow (PC) + rel$	-	-	-	-	-	-	REL	AD	rr	4			
CBEQ <i>opr,rel</i> CBEQA # <i>opr,rel</i> CBEQX # <i>opr,rel</i> CBEQ <i>opr,X+,rel</i> CBEQ <i>X+,rel</i> CBEQ <i>opr,SP,rel</i>	Compare and Branch if Equal	$PC \leftarrow (PC) + 3 + rel ? (A) - (M) = \$00$ $PC \leftarrow (PC) + 3 + rel ? (A) - (M) = \$00$ $PC \leftarrow (PC) + 3 + rel ? (X) - (M) = \$00$ $PC \leftarrow (PC) + 3 + rel ? (A) - (M) = \$00$ $PC \leftarrow (PC) + 2 + rel ? (A) - (M) = \$00$ $PC \leftarrow (PC) + 4 + rel ? (A) - (M) = \$00$							DIR	31	dd rr	5			
										IMM	41	ii rr	4		
											IMM	51	ii rr	4	
											IX1+	61	ff rr	5	
											IX+	71	rr	4	
											SP1	9E61	ff rr	6	
CLC	Clear Carry Bit	$C \leftarrow 0$	-	-	-	-	0		INH	98		1			
CLI	Clear Interrupt Mask	$I \leftarrow 0$	-	-	0	-	-		INH	9A		2			
CLR <i>opr</i> CLRA CLR X CLR H CLR <i>opr,X</i> CLR ,X CLR <i>opr,SP</i>	Clear	$M \leftarrow \$00$ $A \leftarrow \$00$ $X \leftarrow \$00$ $H \leftarrow \$00$ $M \leftarrow \$00$ $M \leftarrow \$00$ $M \leftarrow \$00$							DIR	3F	dd	3			
										INH	4F		1		
											INH	5F		1	
						0	-	-	0	1		INH	8C		1
											IX1	6F	ff	3	
											IX	7F		2	
											SP1	9E6F	ff	4	

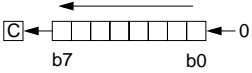
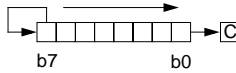
Table 6-1. Instruction Set Summary (Continued)

Source Form	Operation	Description	Effect on CCR						Address Mode	Opcode	Operand	Cycles
			V	H	I	N	Z	C				
CMP #opr CMP opr CMP opr CMP opr,X CMP opr,X CMP ,X CMP opr,SP CMP opr,SP	Compare A with M	(A) - (M)	↓	-	-	↓	↓	↓	IMM DIR EXT IX2 IX1 IX SP1 SP2	A1 B1 C1 D1 E1 F1 9EE1 9ED1	ii dd hh ll ee ff ff ff ff ff ee ff	2 3 4 4 3 2 4 5
COM opr COMA COMX COM opr,X COM ,X COM opr,SP	Complement (One's Complement)	M ← (M̄) = \$FF - (M) A ← (Ā) = \$FF - (M) X ← (X̄) = \$FF - (M) M ← (M̄) = \$FF - (M) M ← (M̄) = \$FF - (M) M ← (M̄) = \$FF - (M)	0	-	-	↓	↓	1	DIR INH INH IX1 IX SP1	33 43 53 63 73 9E63	dd ff ff ff	4 1 1 4 3 5
CPHX #opr CPHX opr	Compare H:X with M	(H:X) - (M:M + 1)	↓	-	-	↓	↓	↓	IMM DIR	65 75	ii ii+1 dd	3 4
CPX #opr CPX opr CPX opr CPX ,X CPX opr,X CPX opr,X CPX opr,SP CPX opr,SP	Compare X with M	(X) - (M)	↓	-	-	↓	↓	↓	IMM DIR EXT IX2 IX1 IX SP1 SP2	A3 B3 C3 D3 E3 F3 9EE3 9ED3	ii dd hh ll ee ff ff ff ff ee ff	2 3 4 4 3 2 4 5
DAA	Decimal Adjust A	(A) <sub>10</sub>	U	-	-	↓	↓	↓	INH	72		2
DBNZ opr,rel DBNZA rel DBNZX rel DBNZ opr,X,rel DBNZ X,rel DBNZ opr,SP,rel	Decrement and Branch if Not Zero	A ← (A) - 1 or M ← (M) - 1 or X ← (X) - 1 PC ← (PC) + 3 + rel ? (result) ≠ 0 PC ← (PC) + 2 + rel ? (result) ≠ 0 PC ← (PC) + 2 + rel ? (result) ≠ 0 PC ← (PC) + 3 + rel ? (result) ≠ 0 PC ← (PC) + 2 + rel ? (result) ≠ 0 PC ← (PC) + 4 + rel ? (result) ≠ 0	-	-	-	-	-	-	DIR INH INH IX1 IX SP1	3B 4B 5B 6B 7B 9E6B	dd rr rr rr ff rr rr ff rr	5 3 3 5 4 6
DEC opr DECA DECX DEC opr,X DEC ,X DEC opr,SP	Decrement	M ← (M) - 1 A ← (A) - 1 X ← (X) - 1 M ← (M) - 1 M ← (M) - 1 M ← (M) - 1	↓	-	-	↓	↓	-	DIR INH INH IX1 IX SP1	3A 4A 5A 6A 7A 9E6A	dd ff ff	4 1 1 4 3 5
DIV	Divide	A ← (H:A)/(X) H ← Remainder	-	-	-	-	↓	↓	INH	52		7

Freescale Semiconductor, Inc.

Table 6-1. Instruction Set Summary (Continued)

Source Form	Operation	Description	Effect on CCR						Address Mode	Opcode	Operand	Cycles
			V	H	I	N	Z	C				
EOR #opr EOR opr EOR opr EOR opr,X EOR opr,X EOR ,X EOR opr,SP EOR opr,SP	Exclusive OR M with A	$A \leftarrow (A \oplus M)$	0	-	-	↑	↑	-	IMM DIR EXT IX2 IX1 IX SP1 SP2	A8 B8 C8 D8 E8 F8 9EE8 9ED8	ii dd hh ll ee ff ff ff ff ff ff	2 3 4 4 3 2 4 5
INC opr INCA INCA INC opr,X INC ,X INC opr,SP	Increment	$M \leftarrow (M) + 1$ $A \leftarrow (A) + 1$ $X \leftarrow (X) + 1$ $M \leftarrow (M) + 1$ $M \leftarrow (M) + 1$ $M \leftarrow (M) + 1$	↑	-	-	↑	↑	-	DIR INH INH IX1 IX SP1	3C 4C 5C 6C 7C 9E6C	dd ff ff ff	4 1 1 4 3 5
JMP opr JMP opr JMP opr,X JMP opr,X JMP ,X	Jump	$PC \leftarrow \text{Jump Address}$	-	-	-	-	-	-	DIR EXT IX2 IX1 IX	BC CC DC EC FC	dd hh ll ee ff ff	2 3 4 3 2
JSR opr JSR opr JSR opr,X JSR opr,X JSR ,X	Jump to Subroutine	$PC \leftarrow (PC) + n$ ( $n = 1, 2, \text{ or } 3$ ) Push (PCL); $SP \leftarrow (SP) - 1$ Push (PCH); $SP \leftarrow (SP) - 1$ $PC \leftarrow \text{Unconditional Address}$	-	-	-	-	-	-	DIR EXT IX2 IX1 IX	BD CD DD ED FD	dd hh ll ee ff ff	4 5 6 5 4
LDA #opr LDA opr LDA opr LDA opr,X LDA opr,X LDA ,X LDA opr,SP LDA opr,SP	Load A from M	$A \leftarrow (M)$	0	-	-	↑	↑	-	IMM DIR EXT IX2 IX1 IX SP1 SP2	A6 B6 C6 D6 E6 F6 9EE6 9ED6	ii dd hh ll ee ff ff ff ff ff	2 3 4 4 3 2 4 5
LDHX #opr LDHX opr	Load H:X from M	$H:X \leftarrow (M:M + 1)$	0	-	-	↑	↑	-	IMM DIR	45 55	ii jj dd	3 4
LDX #opr LDX opr LDX opr LDX opr,X LDX opr,X LDX ,X LDX opr,SP LDX opr,SP	Load X from M	$X \leftarrow (M)$	0	-	-	↑	↑	-	IMM DIR EXT IX2 IX1 IX SP1 SP2	AE BE CE DE EE FE 9EEE 9EDE	ii dd hh ll ee ff ff ff ff ff	2 3 4 4 3 2 4 5
LSL opr LSLA LSLX LSL opr,X LSL ,X LSL opr,SP	Logical Shift Left (Same as ASL)		↑	-	-	↑	↑	↑	DIR INH INH IX1 IX SP1	38 48 58 68 78 9E68	dd ff ff ff ff	4 1 1 4 3 5

Table 6-1. Instruction Set Summary (Continued)

Source Form	Operation	Description	Effect on CCR						Address Mode	Opcode	Operand	Cycles
			V	H	I	N	Z	C				
LSR <i>opr</i> LSRA LSRX LSR <i>opr,X</i> LSR ,X LSR <i>opr,SP</i>	Logical Shift Right		↓	-	-	0	↓	↓	DIR INH INH IX1 IX SP1	34 44 54 64 74 9E64	dd  ff ff	4 1 1 4 3 5
MOV <i>opr,opr</i> MOV <i>opr,X+</i> MOV # <i>opr,opr</i> MOV X+, <i>opr</i>	Move	(M) <sub>Destination</sub> ← (M) <sub>Source</sub> H:X ← (H:X) + 1 (IX+D, DIX+)	0	-	-	↑	↑	-	DD DIX+ IMD IX+D	4E 5E 6E 7E	dd dd dd ii dd dd	5 4 4 4
MUL	Unsigned multiply	X:A ← (X) × (A)	-	0	-	-	-	0	INH	42		5
NEG <i>opr</i> NEGA NEGX NEG <i>opr,X</i> NEG ,X NEG <i>opr,SP</i>	Negate (Two's Complement)	M ← -(M) = \$00 - (M) A ← -(A) = \$00 - (A) X ← -(X) = \$00 - (X) M ← -(M) = \$00 - (M) M ← -(M) = \$00 - (M)	↓	-	-	↑	↑	↑	DIR INH INH IX1 IX SP1	30 40 50 60 70 9E60	dd  ff ff	4 1 1 4 3 5
NOP	No Operation	None	-	-	-	-	-	-	INH	9D		1
NSA	Nibble Swap A	A ← (A[3:0]:A[7:4])	-	-	-	-	-	-	INH	62		3
ORA # <i>opr</i> ORA <i>opr</i> ORA <i>opr</i> ORA <i>opr,X</i> ORA <i>opr,X</i> ORA ,X ORA <i>opr,SP</i> ORA <i>opr,SP</i>	Inclusive OR A and M	A ← (A)   (M)	0	-	-	↑	↑	-	IMM DIR EXT IX2 IX1 IX SP1 SP2	AA BA CA DA EA FA 9EEA 9EDA	ii dd hh ll ee ff ff ff ff ee ff	2 3 4 4 3 2 4 5
PSHA	Push A onto Stack	Push (A); SP ← (SP) - 1	-	-	-	-	-	-	INH	87		2
PSHH	Push H onto Stack	Push (H); SP ← (SP) - 1	-	-	-	-	-	-	INH	8B		2
PSHX	Push X onto Stack	Push (X); SP ← (SP) - 1	-	-	-	-	-	-	INH	89		2
PULA	Pull A from Stack	SP ← (SP + 1); Pull (A)	-	-	-	-	-	-	INH	86		2
PULH	Pull H from Stack	SP ← (SP + 1); Pull (H)	-	-	-	-	-	-	INH	8A		2
PULX	Pull X from Stack	SP ← (SP + 1); Pull (X)	-	-	-	-	-	-	INH	88		2
ROL <i>opr</i> ROLA ROLX ROL <i>opr,X</i> ROL ,X ROL <i>opr,SP</i>	Rotate Left through Carry		↓	-	-	↑	↑	↑	DIR INH INH IX1 IX SP1	39 49 59 69 79 9E69	dd  ff ff	4 1 1 4 3 5

Table 6-1. Instruction Set Summary (Continued)

Source Form	Operation	Description	Effect on CCR						Address Mode	Opcode	Operand	Cycles
			V	H	I	N	Z	C				
ROR <i>opr</i> RORA RORX ROR <i>opr,X</i> ROR ,X ROR <i>opr,SP</i>	Rotate Right through Carry		↓	-	-	↓	↓	↓	DIR INH INH IX1 IX SP1	36 46 56 66 76 9E66	dd  ff ff	4 1 1 4 3 5
RSP	Reset Stack Pointer	SP ← \$FF	-	-	-	-	-	-	INH	9C		1
RTI	Return from Interrupt	SP ← (SP) + 1; Pull (CCR) SP ← (SP) + 1; Pull (A) SP ← (SP) + 1; Pull (X) SP ← (SP) + 1; Pull (PCH) SP ← (SP) + 1; Pull (PCL)	↓	↓	↓	↓	↓	↓	INH	80		7
RTS	Return from Subroutine	SP ← SP + 1; Pull (PCH) SP ← SP + 1; Pull (PCL)	-	-	-	-	-	-	INH	81		4
SBC # <i>opr</i> SBC <i>opr</i> SBC <i>opr</i> SBC <i>opr,X</i> SBC <i>opr,X</i> SBC ,X SBC <i>opr,SP</i> SBC <i>opr,SP</i>	Subtract with Carry	A ← (A) - (M) - (C)	↓	-	-	↓	↓	↓	IMM DIR EXT IX2 IX1 IX SP1 SP2	A2 B2 C2 D2 E2 F2 9EE2 9ED2	ii dd hh ll ee ff ff ff ff ee ff	2 3 4 4 3 2 4 5
SEC	Set Carry Bit	C ← 1	-	-	-	-	-	1	INH	99		1
SEI	Set Interrupt Mask	I ← 1	-	-	1	-	-	-	INH	9B		2
STA <i>opr</i> STA <i>opr</i> STA <i>opr,X</i> STA <i>opr,X</i> STA ,X STA <i>opr,SP</i> STA <i>opr,SP</i>	Store A in M	M ← (A)	0	-	-	↓	↓	-	DIR EXT IX2 IX1 IX SP1 SP2	B7 C7 D7 E7 F7 9EE7 9ED7	dd hh ll ee ff ff ff ff ee ff	3 4 4 3 2 4 5
STHX <i>opr</i>	Store H:X in M	(M:M + 1) ← (H:X)	0	-	-	↓	↓	-	DIR	35	dd	4
STOP	Enable $\overline{IRQ}$ Pin; Stop Oscillator	I ← 0; Stop Oscillator	-	-	0	-	-	-	INH	8E		1
STX <i>opr</i> STX <i>opr</i> STX <i>opr,X</i> STX <i>opr,X</i> STX ,X STX <i>opr,SP</i> STX <i>opr,SP</i>	Store X in M	M ← (X)	0	-	-	↓	↓	-	DIR EXT IX2 IX1 IX SP1 SP2	BF CF DF EF FF 9EEF 9EDF	dd hh ll ee ff ff ff ff ee ff	3 4 4 3 2 4 5

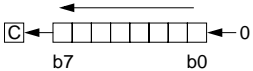

Table 6-1. Instruction Set Summary (Continued)

Source Form	Operation	Description	Effect on CCR						Address Mode	Opcode	Operand	Cycles
			V	H	I	N	Z	C				
SUB #opr SUB opr SUB opr SUB opr,X SUB opr,X SUB ,X SUB opr,SP SUB opr,SP	Subtract	$A \leftarrow (A) - (M)$	↓	-	-	↓	↓	↓	IMM DIR EXT IX2 IX1 IX SP1 SP2	A0 B0 C0 D0 E0 F0 9EE0 9ED0	ii dd hh ll ee ff ff ff ff ee ff	2 3 4 4 3 2 4 5
SWI	Software Interrupt	PC ← (PC) + 1; Push (PCL) SP ← (SP) - 1; Push (PCH) SP ← (SP) - 1; Push (X) SP ← (SP) - 1; Push (A) SP ← (SP) - 1; Push (CCR) SP ← (SP) - 1; I ← 1 PCH ← Interrupt Vector High Byte PCL ← Interrupt Vector Low Byte	-	-	1	-	-	-	INH	83		9
TAP	Transfer A to CCR	$CCR \leftarrow (A)$	↓	↓	↓	↓	↓	↓	INH	84		2
TAX	Transfer A to X	$X \leftarrow (A)$	-	-	-	-	-	-	INH	97		1
TPA	Transfer CCR to A	$A \leftarrow (CCR)$	-	-	-	-	-	-	INH	85		1
TST opr TSTA TSTX TST opr,X TST ,X TST opr,SP	Test for Negative or Zero	$(A) - \$00$ or $(X) - \$00$ or $(M) - \$00$	0	-	-	↓	↓	-	DIR INH INH IX1 IX SP1	3D 4D 5D 6D 7D 9E6D	dd ff ff	3 1 1 3 2 4
TSX	Transfer SP to H:X	$H:X \leftarrow (SP) + 1$	-	-	-	-	-	-	INH	95		2
TXA	Transfer X to A	$A \leftarrow (X)$	-	-	-	-	-	-	INH	9F		1
TXS	Transfer H:X to SP	$(SP) \leftarrow (H:X) - 1$	-	-	-	-	-	-	INH	94		2

Freescale Semiconductor, Inc.

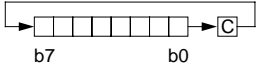
Table 6-1. Instruction Set Summary (Continued)

Source Form	Operation	Description	Effect on CCR						Address Mode	Opcode	Operand	Cycles
			V	H	I	N	Z	C				
A	Accumulator	<i>n</i>										
C	Carry/borrow bit	<i>opr</i>										
CCR	Condition code register	PC										
dd	Direct address of operand	PCH										
dd rr	Direct address of operand and relative offset of branch instruction	PCL										
DD	Direct to direct addressing mode	REL										
DIR	Direct addressing mode	<i>rel</i>										
DIX+	Direct to indexed with post increment addressing mode	rr										
ee ff	High and low bytes of offset in indexed, 16-bit offset addressing	SP1										
EXT	Extended addressing mode	SP2										
ff	Offset byte in indexed, 8-bit offset addressing	SP										
H	Half-carry bit	U										
H	Index register high byte	V										
hh ll	High and low bytes of operand address in extended addressing	X										
I	Interrupt mask	Z										
ii	Immediate operand byte	&										
IMD	Immediate source to direct destination addressing mode											
IMM	Immediate addressing mode	⊕										
INH	Inherent addressing mode	()										
IX	Indexed, no offset addressing mode	-( )										
IX+	Indexed, no offset, post increment addressing mode	#										
IX+D	Indexed with post increment to direct addressing mode	«										
IX1	Indexed, 8-bit offset addressing mode	←										
IX1+	Indexed, 8-bit offset, post increment addressing mode	?										
IX2	Indexed, 16-bit offset addressing mode	:										
M	Memory location	↓										
N	Negative bit	—										

Freescale Semiconductor, Inc.

Table 6-2. Opcode Map

	Bit Manipulation		Branch	Read-Modify-Write						Control			Register/Memory						
	DIR	DIR	REL	DIR	INH	INH	IX1	SP1	IX	INH	INH	IMM	DIR	EXT	IX2	SP2	IX1	SP1	IX
MSB LSB	0	1	2	3	4	5	6	9E6	7	8	9	A	B	C	D	9ED	E	9EE	F
0	BRSET0 3 DIR	BSET0 2 DIR	BRA 2 REL	NEG 2 DIR	NEGA 1 INH	NEGX 1 INH	NEG 2 IX1	NEG 3 SP1	NEG 1 IX	RTI 1 INH	BGE 2 REL	SUB 2 IMM	SUB 2 DIR	SUB 3 EXT	SUB 3 IX2	SUB 4 SP2	SUB 2 IX1	SUB 3 SP1	SUB 1 IX
1	BRCLR0 3 DIR	BCLR0 2 DIR	BRN 2 REL	CBEQ 3 DIR	CBEQA 3 IMM	CBEQX 4 IMM	CBEQ 3 IX1+	CBEQ 4 SP1	CBEQ 2 IX+	RTS 1 INH	BLT 2 REL	CMP 2 IMM	CMP 2 DIR	CMP 3 EXT	CMP 3 IX2	CMP 4 SP2	CMP 2 IX1	CMP 3 SP1	CMP 1 IX
2	BRSET1 3 DIR	BSET1 2 DIR	BHI 2 REL	MUL 1 INH	DIV 1 INH	NSA 1 INH	DAA 1 INH	BGT 2 REL	SBC 2 IMM	SBC 2 DIR	SBC 3 EXT	SBC 3 IX2	SBC 4 SP2	SBC 2 IX1	SBC 3 SP1	SBC 1 IX			
3	BRCLR1 3 DIR	BCLR1 2 DIR	BLS 2 REL	COM 2 DIR	COMA 1 INH	COMX 1 INH	COM 2 IX1	COM 3 SP1	COM 1 IX	SWI 1 INH	BLE 2 REL	CPX 2 IMM	CPX 2 DIR	CPX 3 EXT	CPX 3 IX2	CPX 4 SP2	CPX 2 IX1	CPX 3 SP1	CPX 1 IX
4	BRSET2 3 DIR	BSET2 2 DIR	BCC 2 REL	LSR 2 DIR	LSRA 1 INH	LSRX 1 INH	LSR 2 IX1	LSR 3 SP1	LSR 1 IX	TAP 1 INH	TXS 1 INH	AND 2 IMM	AND 2 DIR	AND 3 EXT	AND 3 IX2	AND 4 SP2	AND 2 IX1	AND 3 SP1	AND 1 IX
5	BRCLR2 3 DIR	BCLR2 2 DIR	BCS 2 REL	STHX 2 DIR	LDHX 3 IMM	LDHX 2 DIR	CPHX 3 IMM	CPHX 2 DIR	TPA 1 INH	TSX 1 INH	BIT 2 IMM	BIT 2 DIR	BIT 3 EXT	BIT 3 IX2	BIT 4 SP2	BIT 2 IX1	BIT 3 SP1	BIT 1 IX	
6	BRSET3 3 DIR	BSET3 2 DIR	BNE 2 REL	ROR 2 DIR	RORA 1 INH	RORX 1 INH	ROR 2 IX1	ROR 3 SP1	ROR 1 IX	PULA 1 INH	LDA 2 IMM	LDA 3 DIR	LDA 3 EXT	LDA 3 IX2	LDA 4 SP2	LDA 2 IX1	LDA 3 SP1	LDA 1 IX	
7	BRCLR3 3 DIR	BCLR3 2 DIR	BEQ 2 REL	ASR 2 DIR	ASRA 1 INH	ASRX 1 INH	ASR 2 IX1	ASR 3 SP1	ASR 1 IX	PSHA 1 INH	TAX 1 INH	AIS 2 IMM	STA 2 DIR	STA 3 EXT	STA 3 IX2	STA 4 SP2	STA 2 IX1	STA 3 SP1	STA 1 IX
8	BRSET4 3 DIR	BSET4 2 DIR	BHCC 2 REL	LSL 2 DIR	LSLA 1 INH	LSLX 1 INH	LSL 2 IX1	LSL 3 SP1	LSL 1 IX	PULX 1 INH	CLC 1 INH	EOR 2 IMM	EOR 2 DIR	EOR 3 EXT	EOR 3 IX2	EOR 4 SP2	EOR 2 IX1	EOR 3 SP1	EOR 1 IX
9	BRCLR4 3 DIR	BCLR4 2 DIR	BHCS 2 REL	ROL 2 DIR	ROLA 1 INH	ROLX 1 INH	ROL 2 IX1	ROL 3 SP1	ROL 1 IX	PSHX 1 INH	SEC 1 INH	ADC 2 IMM	ADC 2 DIR	ADC 3 EXT	ADC 3 IX2	ADC 4 SP2	ADC 2 IX1	ADC 3 SP1	ADC 1 IX
A	BRSET5 3 DIR	BSET5 2 DIR	BPL 2 REL	DEC 2 DIR	DECA 1 INH	DECX 1 INH	DEC 2 IX1	DEC 3 SP1	DEC 1 IX	PULH 1 INH	CLI 1 INH	ORA 2 IMM	ORA 2 DIR	ORA 3 EXT	ORA 3 IX2	ORA 4 SP2	ORA 2 IX1	ORA 3 SP1	ORA 1 IX
B	BRCLR5 3 DIR	BCLR5 2 DIR	BMI 2 REL	DBNZ 3 DIR	DBNZA 2 INH	DBNZX 2 INH	DBNZ 3 IX1	DBNZ 4 SP1	DBNZ 2 IX	PSHH 1 INH	SEI 1 INH	ADD 2 IMM	ADD 2 DIR	ADD 3 EXT	ADD 3 IX2	ADD 4 SP2	ADD 2 IX1	ADD 3 SP1	ADD 1 IX
C	BRSET6 3 DIR	BSET6 2 DIR	BMC 2 REL	INC 2 DIR	INCA 1 INH	INCX 1 INH	INC 2 IX1	INC 3 SP1	INC 1 IX	CLRH 1 INH	RSP 1 INH	JMP 2 DIR	JMP 3 EXT	JMP 3 IX2	JMP 3 IX2	JMP 2 IX1	JMP 3 SP1	JMP 1 IX	
D	BRCLR6 3 DIR	BCLR6 2 DIR	BMS 2 REL	TST 2 DIR	TSTA 1 INH	TSTX 1 INH	TST 2 IX1	TST 3 SP1	TST 1 IX	NOP 1 INH	BSR 2 REL	JSR 2 DIR	JSR 3 EXT	JSR 3 IX2	JSR 3 IX2	JSR 2 IX1	JSR 3 SP1	JSR 1 IX	
E	BRSET7 3 DIR	BSET7 2 DIR	BIL 2 REL	MOV 3 DD	MOV 2 DIX+	MOV 3 IMD	MOV 2 IX+D	STOP 1 INH	*	LDX 2 IMM	LDX 2 DIR	LDX 3 EXT	LDX 3 IX2	LDX 3 IX2	LDX 4 SP2	LDX 2 IX1	LDX 3 SP1	LDX 1 IX	
F	BRCLR7 3 DIR	BCLR7 2 DIR	BIH 2 REL	CLR 2 DIR	CLRA 1 INH	CLRX 1 INH	CLR 2 IX1	CLR 3 SP1	CLR 1 IX	WAIT 1 INH	TXA 1 INH	AIX 2 IMM	STX 2 DIR	STX 3 EXT	STX 3 IX2	STX 4 SP2	STX 2 IX1	STX 3 SP1	STX 1 IX

INH Inherent  
 IMM Immediate  
 DIR Direct  
 EXT Extended  
 DD Direct-Direct  
 IX+D Indexed-Direct  
 REL Relative  
 IX Indexed, No Offset  
 IX1 Indexed, 8-Bit Offset  
 IX2 Indexed, 16-Bit Offset  
 IMM Immediate-Direct  
 DIX+ Direct-Indexed

SP1 Stack Pointer, 8-Bit Offset  
 SP2 Stack Pointer, 16-Bit Offset  
 IX+ Indexed, No Offset with Post Increment  
 IX1+ Indexed, 1-Byte Offset with Post Increment

Low Byte of Opcode in Hexadecimal

MSB LSB	0
0	BRSET0 3 DIR

High Byte of Opcode in Hexadecimal  
 Cycles  
 Opcode Mnemonic  
 Number of Bytes / Addressing Mode

\*Pre-byte for stack pointer indexed instructions



## Section 7. System Integration Module (SIM)

### 7.1 Contents

7.2	Introduction . . . . .	78
7.3	SIM Bus Clock Control and Generation . . . . .	81
7.3.1	Bus Timing . . . . .	81
7.3.2	Clock Start-Up from POR . . . . .	81
7.3.3	Clocks in Stop Mode and Wait Mode . . . . .	81
7.4	Reset and System Initialization . . . . .	82
7.4.1	External Pin Reset . . . . .	82
7.4.2	Active Resets from Internal Sources . . . . .	83
7.4.2.1	Power-On Reset . . . . .	84
7.4.2.2	Computer Operating Properly (COP) Reset . . . . .	85
7.4.2.3	Illegal Opcode Reset . . . . .	86
7.4.2.4	Illegal Address Reset . . . . .	86
7.5	SIM Counter . . . . .	86
7.5.1	SIM Counter During Power-On Reset . . . . .	86
7.5.2	SIM Counter During Stop Mode Recovery . . . . .	87
7.5.3	SIM Counter and Reset States . . . . .	87
7.6	Exception Control . . . . .	87
7.6.1	Interrupts . . . . .	88
7.6.1.1	Hardware Interrupts . . . . .	90
7.6.1.2	SWI Instruction . . . . .	91
7.6.2	Interrupt Status Registers . . . . .	91
7.6.2.1	Interrupt Status Register 1 . . . . .	93
7.6.2.2	Interrupt Status Register 2 . . . . .	93
7.6.3	Reset . . . . .	94
7.6.4	Break Interrupts . . . . .	94
7.6.5	Status Flag Protection in Break Mode . . . . .	94
7.7	Low-Power Modes . . . . .	95

7.7.1 Wait Mode .....95  
 7.7.2 Stop Mode .....96  
 7.8 SIM Registers .....98  
 7.8.1 SIM Break Status Register (SBSR) .....98  
 7.8.2 SIM Reset Status Register (SRSR) .....99  
 7.8.3 SIM Break Flag Control Register (SBFCR) .....100

**7.2 Introduction**

This section describes the system integration module, which supports up to 16 external and/or internal interrupts. Together with the CPU, the SIM controls all MCU activities. A block diagram of the SIM is shown in **Figure 7-1**. **Table 7-1** shows a summary of the SIM I/O registers. The SIM is a system state controller that coordinates CPU and exception timing. The SIM is responsible for:

- Bus clock generation and control for CPU and peripherals:
  - Stop/wait/reset/break entry and recovery
  - Internal clock control
- Master reset control, including power-on reset (POR) and COP timeout
- Interrupt control:
  - Acknowledge timing
  - Arbitration control timing
  - Vector address generation
- CPU enable/disable timing
- Modular architecture expandable to 128 interrupt sources

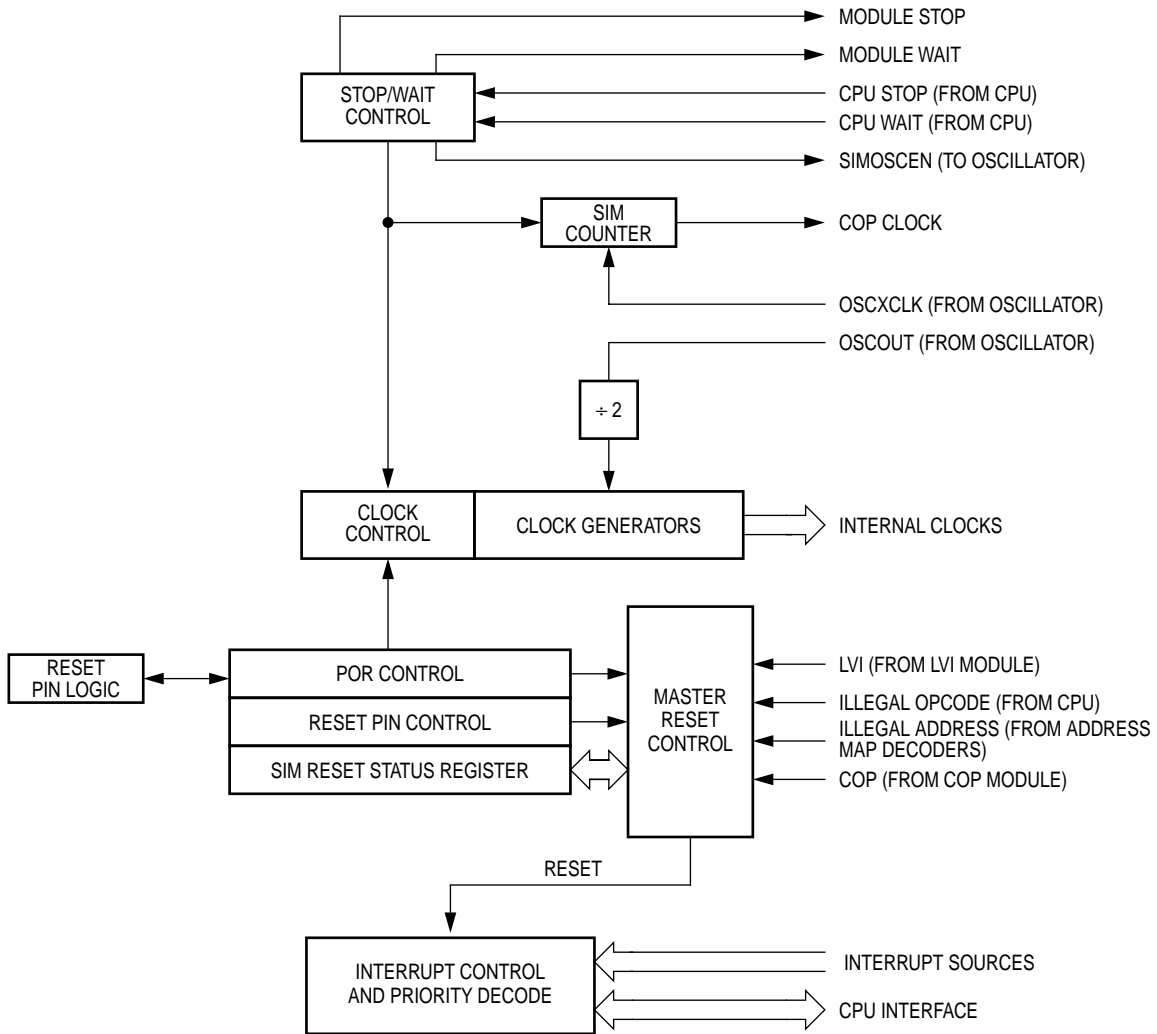

**Figure 7-1. SIM Block Diagram**

Freescale Semiconductor, Inc.

Table 7-1. SIM I/O Register Summary

Addr.	Register Name	Bit 7	6	5	4	3	2	1	Bit 0
\$FE00	SIM Break Status Register (SBSR)	Read:	R	R	R	R	R	SBSW	R
		Write:						Note	
		Reset:	0	0	0	0	0	0	0
\$FE01	SIM Reset Status Register (SRSR)	Read:	POR	PIN	COP	ILOP	ILAD	0	0
		Write:							
		POR:	1	0	0	0	0	0	0
\$FE03	SIM Break Flag Control Register (SBFCR)	Read:	BCFE	R	R	R	R	R	R
		Write:							
		Reset:	0						
\$FE04	Interrupt Status Register 1 (INT1)	Read:	IF6	IF5	IF4	IF3	IF2	IF1	0
		Write:	R	R	R	R	R	R	R
		Reset:	0	0	0	0	0	0	0
\$FE05	Interrupt Status Register 2 (INT2)	Read:	0	0	0	0	IF10	IF9	IF8
		Write:	R	R	R	R	R	R	R
		Reset:	0	0	0	0	0	0	0

Note: Writing a logic 0 clears SBSW.  = Unimplemented R = Reserved

Table 7-2 shows the internal signal names used in this section.

Table 7-2. Signal Name Conventions

Signal Name	Description
OSCXCLK	Buffered version of OSC1 from the oscillator
OSCOUT	The OSCXCLK frequency divided by two. This signal is again divided by two in the SIM to generate the internal bus clocks. (Bus clock = OSCXCLK divided by four)
IAB	Internal address bus
IDB	Internal data bus
PORRST	Signal from the power-on reset module to the SIM
IRST	Internal reset signal
R/W	Read/write signal



### 7.3 SIM Bus Clock Control and Generation

The bus clock generator provides system clock signals for the CPU and peripherals on the MCU. The system clocks are generated from an incoming clock, OSCOUT, as shown in **Figure 7-2**.

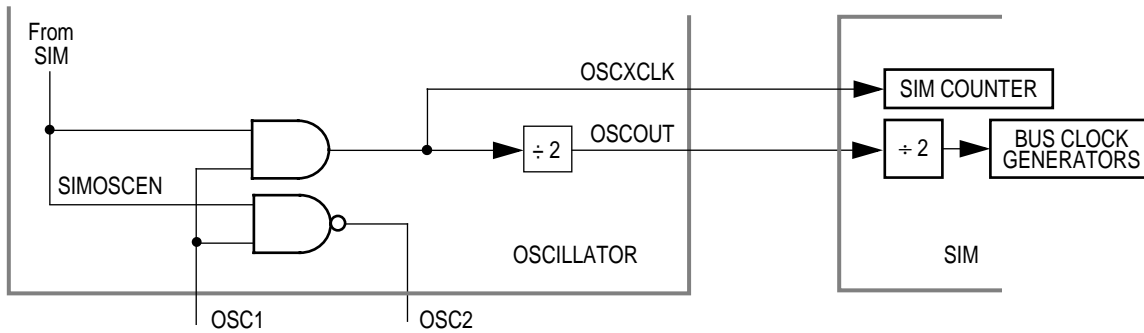

**Figure 7-2. OSC Clock Signals**

#### 7.3.1 Bus Timing

In user mode, the internal bus frequency is the oscillator frequency (OSCXCLK) divided by four.

#### 7.3.2 Clock Start-Up from POR

When the power-on reset module generates a reset, the clocks to the CPU and peripherals are inactive and held in an inactive phase until after the 4096 OSCXCLK cycle POR timeout has completed. The  $\overline{RST}$  is driven low by the SIM during this entire period. The IBUS clocks start upon completion of the timeout.

#### 7.3.3 Clocks in Stop Mode and Wait Mode

Upon exit from stop mode (by an interrupt, break, or reset), the SIM allows OSCXCLK to clock the SIM counter. The CPU and peripheral clocks do not become active until after the stop delay timeout. This timeout is selectable as 4096 or 32 OSCXCLK cycles. (See **7.7.2 Stop Mode**.)

In wait mode, the CPU clocks are inactive. The SIM also produces two sets of clocks for other modules. Refer to the wait mode subsection of each module to see if the module is active or inactive in wait mode. Some modules can be programmed to be active in wait mode.

## 7.4 Reset and System Initialization

The MCU has the following reset sources:

- Power-on reset module (POR)
- External reset pin ( $\overline{RST}$ )
- Computer operating properly module (COP)
- Illegal opcode
- Illegal address

All of these resets produce the vector \$FFFE–FFFF (\$FEFE–FEFF in monitor mode) and assert the internal reset signal (IRST). IRST causes all registers to be returned to their default values and all modules to be returned to their reset states.

An internal reset clears the SIM counter (see 7.5 SIM Counter), but an external reset does not. Each of the resets sets a corresponding bit in the SIM reset status register (SRSR) (see 7.8 SIM Registers).

### 7.4.1 External Pin Reset

Pulling the asynchronous  $\overline{RST}$  pin low halts all processing. The PIN bit of the SIM reset status register (SRSR) is set as long as  $\overline{RST}$  is held low for a minimum of 67 OSCXCLK cycles, assuming that the POR was the source of the reset (see Table 7-3. PIN Bit Set Timing). Figure 7-3 shows the relative timing.

Table 7-3. PIN Bit Set Timing

Reset Type	Number of Cycles Required to Set PIN
POR	4163 (4096 + 64 + 3)
All others	67 (64 + 3)

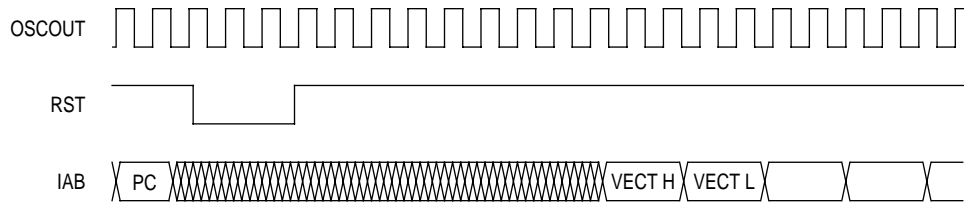

Figure 7-3. External Reset Timing

7.4.2 Active Resets from Internal Sources

SIM module in HC08 has the capability to drive the  $\overline{RST}$  pin low when internal reset events occur.

All internal reset sources actively pull the  $\overline{RST}$  pin low for 32 OSCXCLK cycles to allow resetting of external peripherals. The internal reset signal IRST continues to be asserted for an additional 32 cycles (see Figure 7-4. Internal Reset Timing). An internal reset can be caused by an illegal address, illegal opcode, COP timeout, or POR (see Figure 7-5. Sources of Internal Reset). Note that for POR resets, the SIM cycles through 4096 OSCXCLK cycles during which the SIM forces the  $\overline{RST}$  pin low. The internal reset signal then follows the sequence from the falling edge of  $\overline{RST}$  shown in Figure 7-4.

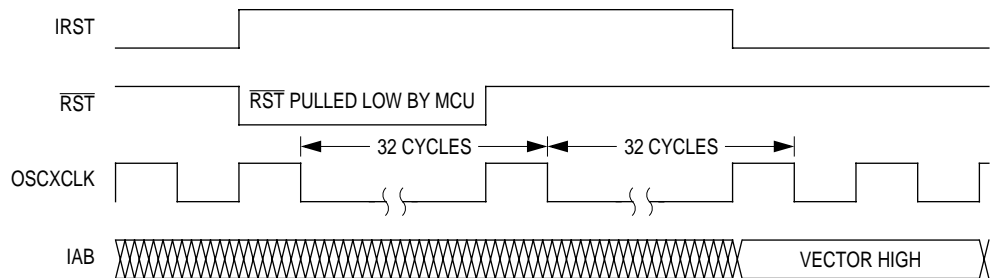
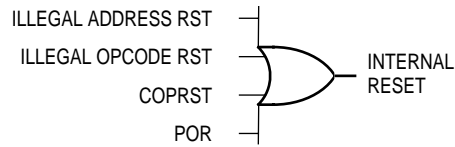

Figure 7-4. Internal Reset Timing

The COP reset is asynchronous to the bus clock.



**Figure 7-5. Sources of Internal Reset**

The active reset feature allows the part to issue a reset to peripherals and other chips within a system built around the MCU.

#### 7.4.2.1 Power-On Reset

When power is first applied to the MCU, the power-on reset module (POR) generates a pulse to indicate that power-on has occurred. The external reset pin ( $\overline{\text{RST}}$ ) is held low while the SIM counter counts out 4096 OSCXCLK cycles. Sixty-four OSCXCLK cycles later, the CPU and memories are released from reset to allow the reset vector sequence to occur.

At power-on, the following events occur:

- A POR pulse is generated.
- The internal reset signal is asserted.
- The SIM enables the oscillator to drive OSCXCLK.
- Internal clocks to the CPU and modules are held inactive for 4096 OSCXCLK cycles to allow stabilization of the oscillator.
- The  $\overline{\text{RST}}$  pin is driven low during the oscillator stabilization time.
- The POR bit of the SIM reset status register (SRSR) is set and all other bits in the register are cleared.

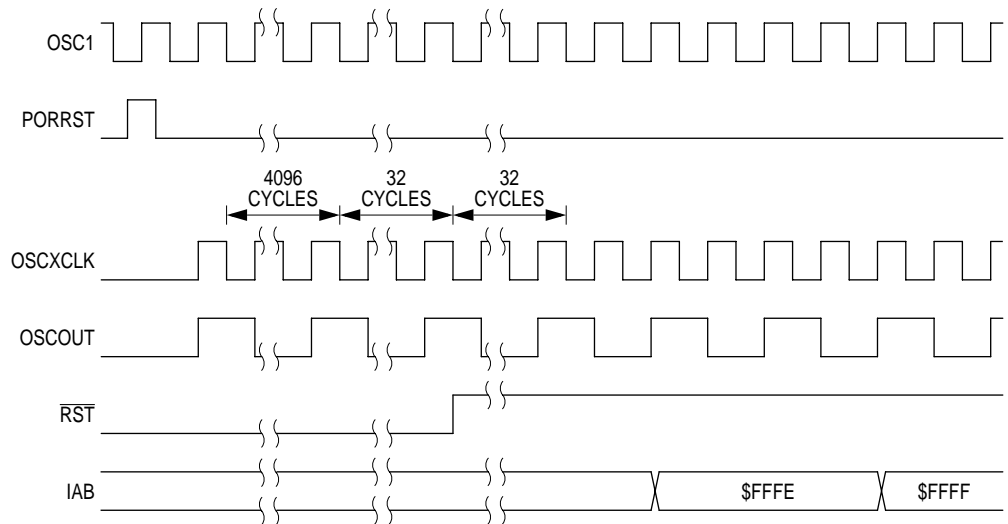

Figure 7-6. POR Recovery

7.4.2.2 Computer Operating Properly (COP) Reset

An input to the SIM is reserved for the COP reset signal. The overflow of the COP counter causes an internal reset and sets the COP bit in the SIM reset status register (SRSR). The SIM actively pulls down the  $\overline{RST}$  pin for all internal reset sources.

To prevent a COP module timeout, write any value to location \$FFFF. Writing to location \$FFFF clears the COP counter and bits 12 through 5 of the SIM counter. The SIM counter output, which occurs at least every  $2^{12} - 2^4$  OSCXCLK cycles, drives the COP counter. The COP should be serviced as soon as possible out of reset to guarantee the maximum amount of time before the first timeout.

The COP module is disabled if the  $\overline{RST}$  pin or the  $\overline{IRQ}$  is held at  $V_{TST}$  while the MCU is in monitor mode. The COP module can be disabled only through combinational logic conditioned with the high voltage signal on the  $\overline{RST}$  pin or the  $\overline{IRQ}$  pin. This prevents the COP from becoming disabled as a result of external noise. During a break state,  $V_{TST}$  on the  $\overline{RST}$  pin disables the COP module.

### 7.4.2.3 Illegal Opcode Reset

The SIM decodes signals from the CPU to detect illegal instructions. An illegal instruction sets the ILOP bit in the SIM reset status register (SRSR) and causes a reset.

If the stop enable bit, STOP, in the configure register 1 (CONFIG1) is logic zero, the SIM treats the STOP instruction as an illegal opcode and causes an illegal opcode reset. The SIM actively pulls down the  $\overline{\text{RST}}$  pin for all internal reset sources.

### 7.4.2.4 Illegal Address Reset

An opcode fetch from an unmapped address generates an illegal address reset. The SIM verifies that the CPU is fetching an opcode prior to asserting the ILAD bit in the SIM reset status register (SRSR) and resetting the MCU. A data fetch from an unmapped address does not generate a reset. The SIM actively pulls down the  $\overline{\text{RST}}$  pin for all internal reset sources.

## 7.5 SIM Counter

The SIM counter is used by the power-on reset module (POR) and in stop mode recovery to allow the oscillator time to stabilize before enabling the internal bus (IBUS) clocks. The SIM counter also serves as a prescaler for the computer operating properly module (COP). The SIM counter overflow supplies the clock for the COP module. The SIM counter is 12 bits long and is clocked by the falling edge of OSCXCLK.

### 7.5.1 SIM Counter During Power-On Reset

The power-on reset module (POR) detects power applied to the MCU. At power-on, the POR circuit asserts the signal PORRST. Once the SIM is initialized, it enables the oscillator to drive the bus clock state machine.

### 7.5.2 SIM Counter During Stop Mode Recovery

The SIM counter also is used for stop mode recovery. The STOP instruction clears the SIM counter. After an interrupt, break, or reset, the SIM senses the state of the short stop recovery bit, SSREC, in the configure register 1 (CONFIG1). If the SSREC bit is a logic one, then the stop recovery is reduced from the normal delay of 4096 OSCXCLK cycles down to 32 OSCXCLK cycles. This is ideal for applications using canned oscillators that do not require long start-up times from stop mode. External crystal applications should use the full stop recovery time, that is, with SSREC cleared.

### 7.5.3 SIM Counter and Reset States

External reset has no effect on the SIM counter (see [7.7.2 Stop Mode](#)). The SIM counter is free-running after all reset states (see [7.4.2 Active Resets from Internal Sources](#) for counter control and internal reset recovery sequences).

## 7.6 Exception Control

Normally, sequential program execution can be changed in three different ways:

- Interrupts
  - Maskable hardware CPU interrupts
  - Non-maskable software interrupt instruction (SWI)
- Reset
- Break interrupts

7.6.1 Interrupts

An interrupt temporarily changes the sequence of program execution to respond to a particular event. **Figure 7-9** flow charts the handling of system interrupts.

Interrupts are latched, and arbitration is performed in the SIM at the start of interrupt processing. The arbitration result is a constant that the CPU uses to determine which vector to fetch. Once an interrupt is latched by the SIM, no other interrupt can take precedence, regardless of priority, until the latched interrupt is serviced (or the I bit is cleared).

At the beginning of an interrupt, the CPU saves the CPU register contents on the stack and sets the interrupt mask (I bit) to prevent additional interrupts. At the end of an interrupt, the RTI instruction recovers the CPU register contents from the stack so that normal processing can resume. **Figure 7-7** shows interrupt entry timing. **Figure 7-8** shows interrupt recovery timing.

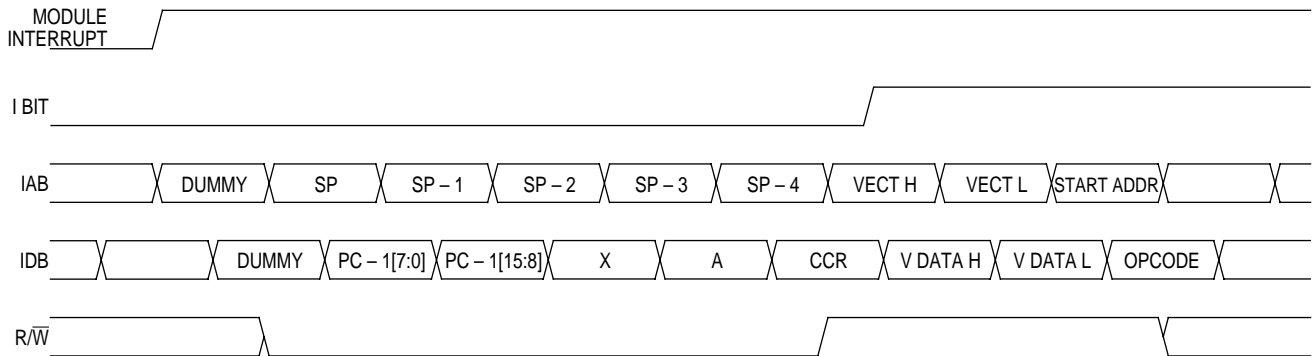

Figure 7-7 .Interrupt Entry

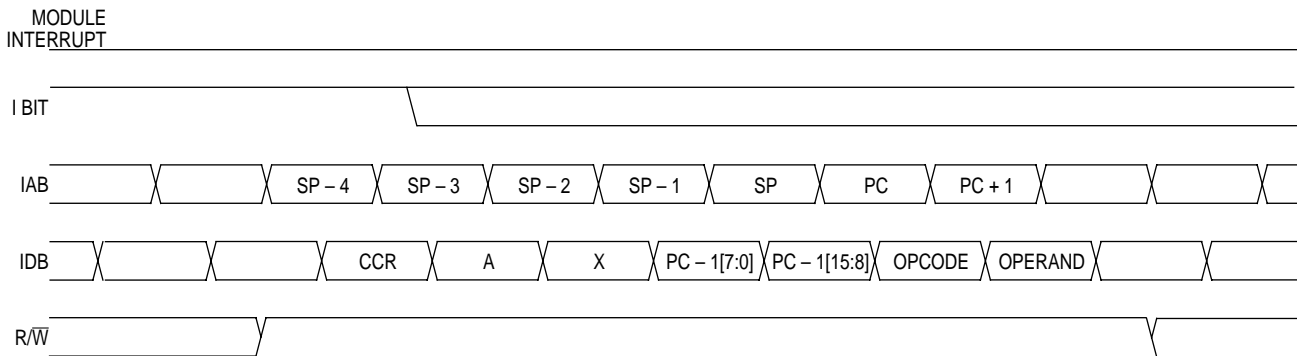

Figure 7-8. Interrupt Recovery



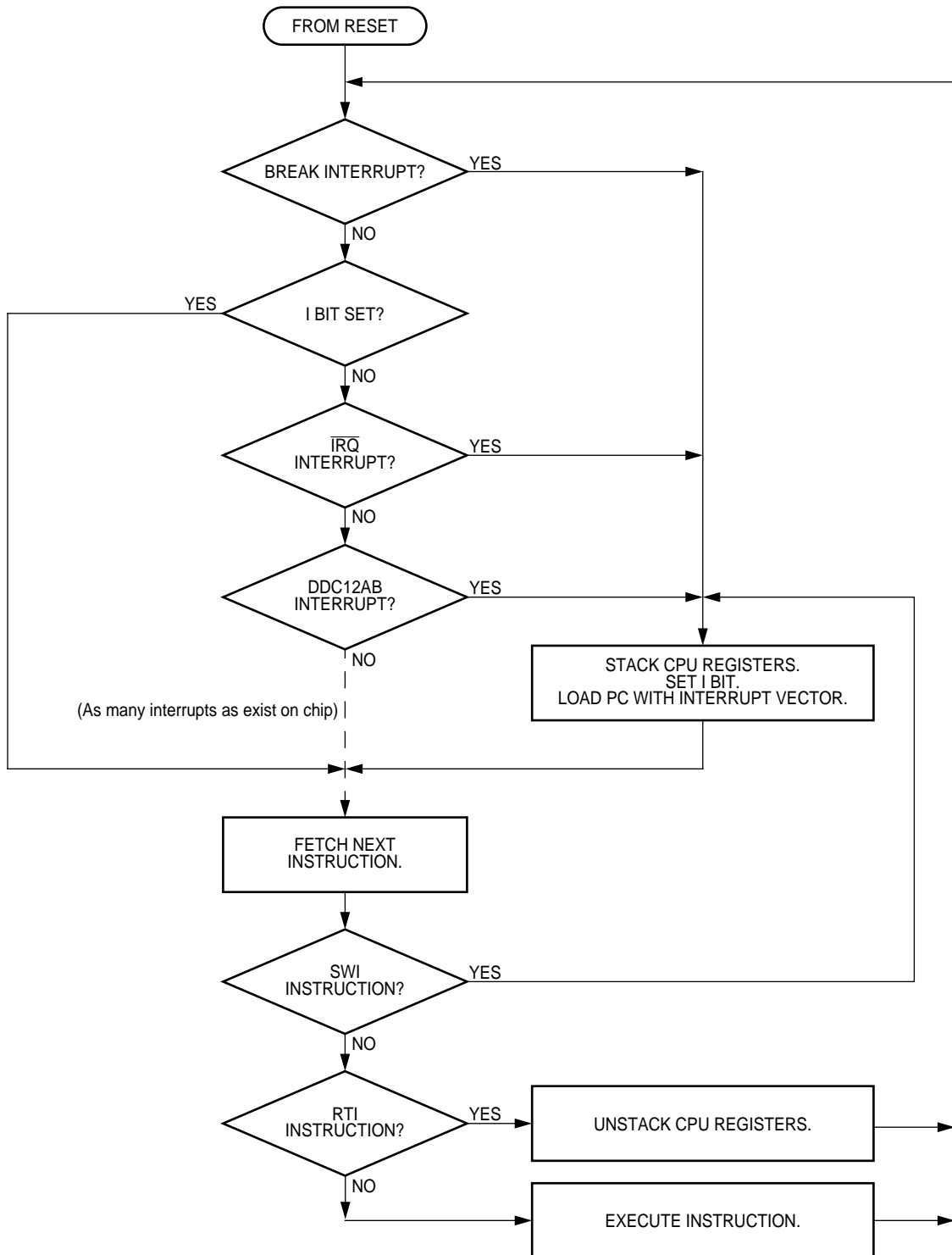

Figure 7-9. Interrupt Processing

Interrupts are latched, and arbitration is performed in the SIM at the start of interrupt processing. The arbitration result is a constant that the CPU uses to determine which vector to fetch. Once an interrupt is latched by the SIM, no other interrupt may take precedence, regardless of priority, until the latched interrupt is serviced (or the I bit is cleared). (See [Figure 7-9. Interrupt Processing.](#))

7.6.1.1 Hardware Interrupts

A hardware interrupt does not stop the current instruction. Processing of a hardware interrupt begins after completion of the current instruction. When the current instruction is complete, the SIM checks all pending hardware interrupts. If interrupts are not masked (I bit clear in the condition code register), and if the corresponding interrupt enable bit is set, the SIM proceeds with interrupt processing; otherwise, the next instruction is fetched and executed.

If more than one interrupt is pending at the end of an instruction execution, the highest priority interrupt is serviced first. [Figure 7-10](#) demonstrates what happens when two interrupts are pending. If an interrupt is pending upon exit from the original interrupt service routine, the pending interrupt is serviced before the LDA instruction is executed.

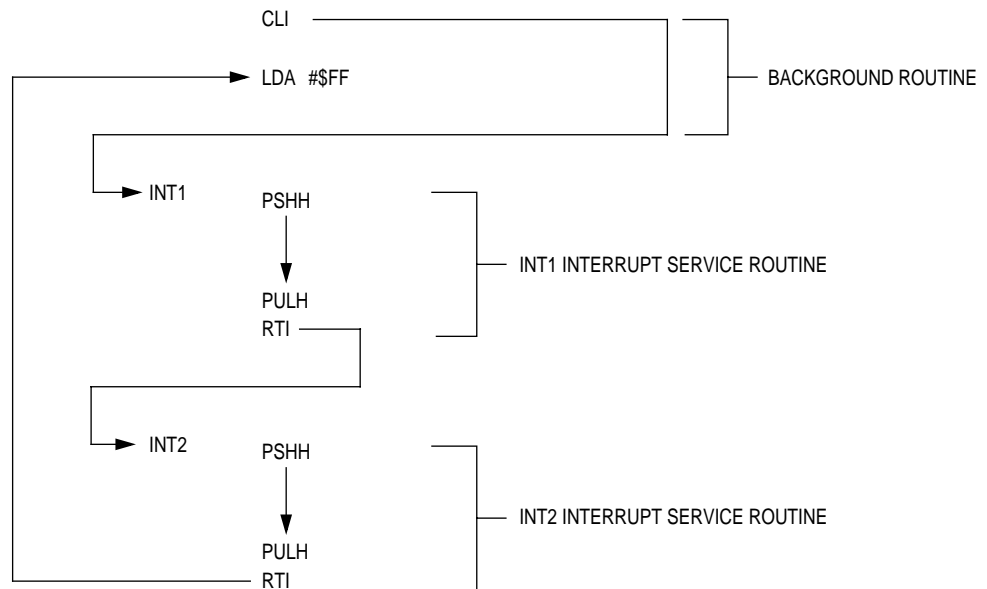

Figure 7-10 . Interrupt Recognition Example

The LDA opcode is pre-fetched by both the INT1 and INT2 RTI instructions. However, in the case of the INT1 RTI pre-fetch, this is a redundant operation.

**NOTE:** *To maintain compatibility with the M6805 Family, the H register is not pushed on the stack during interrupt entry. If the interrupt service routine modifies the H register or uses the indexed addressing mode, software should save the H register and then restore it prior to exiting the routine.*

### 7.6.1.2 SWI Instruction

The SWI instruction is a non-maskable instruction that causes an interrupt regardless of the state of the interrupt mask (I bit) in the condition code register.

**NOTE:** *A software interrupt pushes PC onto the stack. A software interrupt does not push PC – 1, as a hardware interrupt does.*

### 7.6.2 Interrupt Status Registers

The flags in the interrupt status registers identify maskable interrupt sources. **Table 7-4** summarizes the interrupt sources and the interrupt status register flags that they set. The interrupt status registers can be useful for debugging.

Table 7-4. Interrupt Sources

Source	Flag	Mask <sup>1</sup>	INT Register Flag	Priority <sup>2</sup>	Vector Address
Reset	None	None	None	0	\$FFFE-\$FFFF
SWI Instruction	None	None	None	0	\$FFFC-\$FFFD
IRQ pin	IRQF	IMASK	IF1	1	\$FFFA-\$FFFB
Reserved	—	—	—	2	\$FFF8-\$FFF9
DDC12AB	ALIF	DIEN	IF3	3	\$FFF6-\$FFF7
	NAKIF				
	RXIF				
	TXIF				
	SCLIF	SCLIEN			
Reserved	—	—	—	4	\$FFF4-\$FFF5
TIM channel 0	CH0F	CH0IE	IF5	5	\$FFF2-\$FFF3
TIM channel 1	CH1F	CH1IE	IF6	6	\$FFF0-\$FFF1
TIM overflow	TOF	TOIE	IF7	7	\$FFEE-\$FFEF
Sync processor	VSIF	VSIE	IF8	8	\$FFEC-\$FFED
	LVSIF	LVSIE			
Reserved	—	—	—	9	\$FFEA-\$FFEB
ADC conversion complete	COCO	AIEN	IF10	10	\$FFE8-\$FFE9
Reserved	—	—	—	—	\$FFE6-\$FFE7

1. The I bit in the condition code register is a global mask for all interrupts sources except the SWI instruction.

2. 0 = highest priority

7.6.2.1 Interrupt Status Register 1

Address: \$FE04

	Bit 7	6	5	4	3	2	1	Bit 0
Read:	IF6	IF5	IF4	IF3	IF2	IF1	0	0
Write:	R	R	R	R	R	R	R	R
Reset:	0	0	0	0	0	0	0	0

R = Reserved

Figure 7-11. Interrupt Status Register 1 (INT1)

IF6–IF1 — Interrupt Flags 6–1

These flags indicate the presence of interrupt requests from the sources shown in [Table 7-4](#).

- 1 = Interrupt request present
- 0 = No interrupt request present

Bit 1 and Bit 0 — Always read 0

7.6.2.2 Interrupt Status Register 2

Address: \$FE05

	Bit 7	6	5	4	3	2	1	Bit 0
Read:	0	0	0	0	IF10	IF9	IF8	IF7
Write:	R	R	R	R	R	R	R	R
Reset:	0	0	0	0	0	0	0	0

R = Reserved

Figure 7-12. Interrupt Status Register 2 (INT2)

IF10–IF7 — Interrupt Flags 6–1

These flags indicate the presence of interrupt requests from the sources shown in [Table 7-4](#).

- 1 = Interrupt request present
- 0 = No interrupt request present

Bit 7 and Bit 4 — Always read 0

### 7.6.3 Reset

All reset sources always have equal and highest priority and cannot be arbitrated.

### 7.6.4 Break Interrupts

The break module can stop normal program flow at a software-programmable break point by asserting its break interrupt output (see [Section 18. Break Module \(BRK\)](#)). The SIM puts the CPU into the break state by forcing it to the SWI vector location. Refer to the break interrupt subsection of each module to see how each module is affected by the break state.

### 7.6.5 Status Flag Protection in Break Mode

The SIM controls whether status flags contained in other modules can be cleared during break mode. The user can select whether flags are protected from being cleared by properly initializing the break clear flag enable bit (BCFE) in the SIM break flag control register (SBFCR).

Protecting flags in break mode ensures that set flags will not be cleared while in break mode. This protection allows registers to be freely read and written during break mode without losing status flag information.

Setting the BCFE bit enables the clearing mechanisms. Once cleared in break mode, a flag remains cleared even when break mode is exited. Status flags with a two-step clearing mechanism — for example, a read of one register followed by the read or write of another — are protected, even when the first step is accomplished prior to entering break mode. Upon leaving break mode, execution of the second step will clear the flag as normal.

## 7.7 Low-Power Modes

Executing the WAIT or STOP instruction puts the MCU in a low-power-consumption mode for standby situations. The SIM holds the CPU in a non-clocked state. The operation of each of these modes is described below. Both STOP and WAIT clear the interrupt mask (I) in the condition code register, allowing interrupts to occur.

### 7.7.1 Wait Mode

In wait mode, the CPU clocks are inactive while the peripheral clocks continue to run. **Figure 7-13** shows the timing for wait mode entry.

A module that is active during wait mode can wake up the CPU with an interrupt if the interrupt is enabled. Stacking for the interrupt begins one cycle after the WAIT instruction during which the interrupt occurred. In wait mode, the CPU clocks are inactive. Refer to the wait mode subsection of each module to see if the module is active or inactive in wait mode. Some modules can be programmed to be active in wait mode.

Wait mode can also be exited by a reset or break. A break interrupt during wait mode sets the SIM break stop/wait bit, SBSW, in the SIM break status register (SBSR). If the COP disable bit, COPD, in configuration register 1 (CONFIG1) is logic zero, then the computer operating properly module (COP) is enabled and remains active in wait mode.

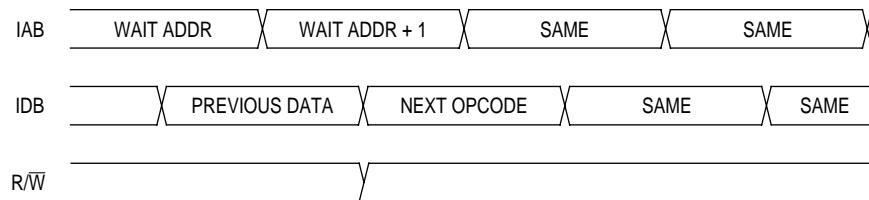

NOTE: Previous data can be operand data or the WAIT opcode, depending on the last instruction.

**Figure 7-13. Wait Mode Entry Timing**

**Figure 7-14** and **Figure 7-15** show the timing for WAIT recovery.

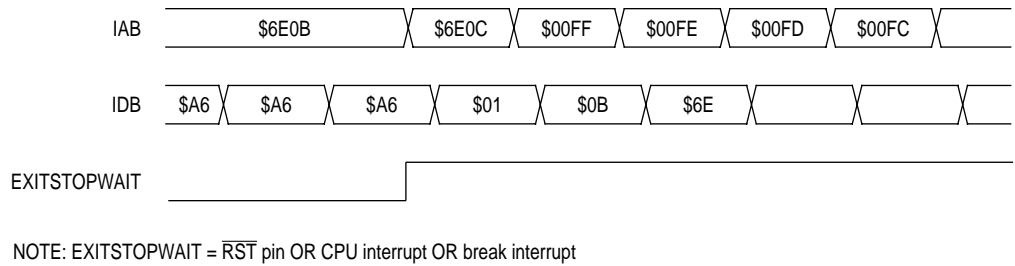

Figure 7-14. Wait Recovery from Interrupt or Break

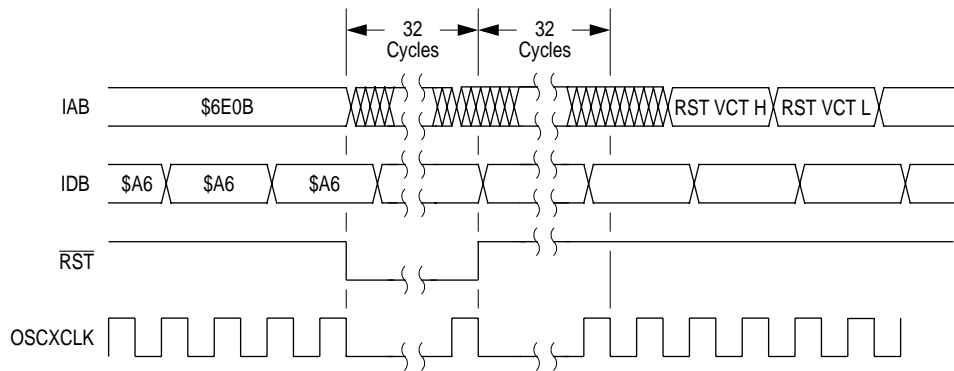

Figure 7-15. Wait Recovery from Internal Reset

### 7.7.2 Stop Mode

In stop mode, the SIM counter is reset and the system clocks are disabled. An interrupt request from a module can cause an exit from stop mode. Stacking for interrupts begins after the selected stop recovery time has elapsed. Reset or break also causes an exit from stop mode.

The SIM disables the oscillator signals (OSCOOUT and OSCXCLK) in stop mode, stopping the CPU and peripherals. Stop recovery time is selectable using the SSREC bit in configuration register 1 (CONFIG1). If SSREC is set, stop recovery is reduced from the normal delay of 4096 OSCXCLK cycles down to 32. This is ideal for applications using canned oscillators that do not require long start-up times from stop mode.

**NOTE:** External crystal applications should use the full stop recovery time by clearing the SSREC bit.



A break interrupt during stop mode sets the SIM break stop/wait bit (SBSW) in the SIM break status register (SBSR).

The SIM counter is held in reset from the execution of the STOP instruction until the beginning of stop recovery. It is then used to time the recovery period. **Figure 7-16** shows stop mode entry timing.

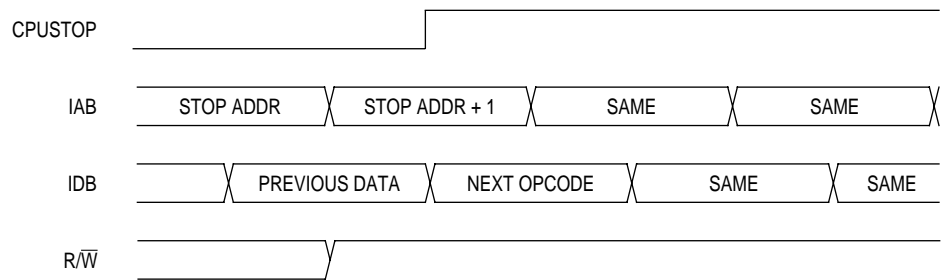

NOTE: Previous data can be operand data or the STOP opcode, depending on the last instruction.

**Figure 7-16. Stop Mode Entry Timing**

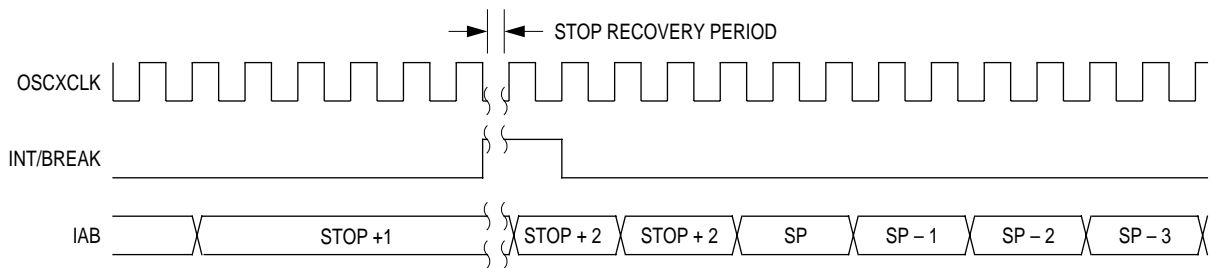

**Figure 7-17. Stop Mode Recovery from Interrupt or Break**

## 7.8 SIM Registers

The SIM has three memory mapped registers. [Table 7-5](#) shows the mapping of these registers.

**Table 7-5. SIM Registers Summary**

Address	Register	Access Mode
\$FE00	SBSR	User
\$FE01	SRSR	User
\$FE03	SBFCR	User

### 7.8.1 SIM Break Status Register (SBSR)

The SIM break status register contains a flag to indicate that a break caused an exit from stop or wait mode.

Address: \$FE00

	Bit 7	6	5	4	3	2	1	Bit 0
Read:	R	R	R	R	R	R	SBSW	R
Write:	R	R	R	R	R	R	Note	R
Reset:	0	0	0	0	0	0	0	0

Note: Writing a logic 0 clears SBSW. R = Reserved

**Figure 7-18. SIM Break Status Register (SBSR)**

#### SBSW — SIM Break Stop/Wait Bit

This status bit is useful in applications requiring a return to wait or stop mode after exiting from a break interrupt. Clear SBSW by writing a logic 0 to it. Reset clears SBSW.

1 = Stop mode or wait mode was exited by break interrupt

0 = Stop mode or wait mode was not exited by break interrupt

SBSW can be read within the break interrupt routine. The user can modify the return address on the stack by subtracting one from it. The following code is an example.

```

;This code works if the H register has been pushed onto the stack in the break
;service routine software. This code should be executed at the end of the break
;service routine software.

HIBYTE EQU 5

LOBYTE EQU 6

; If not SBSW, do RTI

BRCLR SBSW,SBSR, RETURN ;See if wait mode or stop mode was exited by
;break.

TST LOBYTE,SP ;If RETURNLO is not zero,
BNE DOLO ;then just decrement low byte.
DEC HIBYTE,SP ;Else deal with high byte, too.

DOLO DEC LOBYTE,SP ;Point to WAIT/STOP opcode.

RETURN PULH ;Restore H register.
RTI
    
```

### 7.8.2 SIM Reset Status Register (SRSR)

This register contains six flags that show the source of the last reset. Clear the SIM reset status register by reading it. A power-on reset sets the POR bit and clears all other bits in the register.

Address: \$FE01

	Bit 7	6	5	4	3	2	1	Bit 0
Read:	POR	PIN	COP	ILOP	ILAD	0	0	0
Write:								
POR:	1	0	0	0	0	0	0	0

 = Unimplemented

**Figure 7-19. SIM Reset Status Register (SRSR)**

POR — Power-On Reset Bit  
 1 = Last reset caused by POR circuit  
 0 = Read of SRSR

PIN — External Reset Bit

1 = Last reset caused by external reset pin ( $\overline{RST}$ )

0 = POR or read of SRSR

COP — Computer Operating Properly Reset Bit

1 = Last reset caused by COP counter

0 = POR or read of SRSR

ILOP — Illegal Opcode Reset Bit

1 = Last reset caused by an illegal opcode

0 = POR or read of SRSR

ILAD — Illegal Address Reset Bit (opcode fetches only)

1 = Last reset caused by an opcode fetch from an illegal address

0 = POR or read of SRSR

### 7.8.3 SIM Break Flag Control Register (SBFCR)

The SIM break flag control register contains a bit that enables software to clear status bits while the MCU is in a break state.

Address: \$FE03

	Bit 7	6	5	4	3	2	1	Bit 0
Read:	BCFE	R	R	R	R	R	R	R
Write:								
Reset:	0							
	<div style="border: 1px solid black; display: inline-block; padding: 2px;">R</div> = Reserved							

**Figure 7-20. SIM Break Flag Control Register (SBFCR)**

BCFE — Break Clear Flag Enable Bit

This read/write bit enables software to clear status bits by accessing status registers while the MCU is in a break state. To clear status bits during the break state, the BCFE bit must be set.

1 = Status bits clearable during break

0 = Status bits not clearable during break

## Section 8. Oscillator (OSC)

### 8.1 Contents

8.2	Introduction . . . . .	101
8.3	Oscillator External Connections . . . . .	102
8.4	I/O Signals . . . . .	103
8.4.1	Crystal Amplifier Input Pin (OSC1) . . . . .	103
8.4.2	Crystal Amplifier Output Pin (OSC2) . . . . .	103
8.4.3	Oscillator Enable Signal (SIMOSCEN) . . . . .	103
8.4.4	External Clock Source (OSCXCLK) . . . . .	103
8.4.5	Oscillator Out (OSCOUT) . . . . .	103
8.5	Low Power Modes . . . . .	104
8.5.1	Wait Mode . . . . .	104
8.5.2	Stop Mode . . . . .	104
8.6	Oscillator During Break Mode . . . . .	104

### 8.2 Introduction

The oscillator circuit is designed for use with crystals or ceramic resonators. The oscillator circuit generates the crystal clock signal, OSCXCLK, at the frequency of the crystal. This signal is divided by two before being passed on to the SIM for bus clock generation. **Figure 8-1** shows the structure of the oscillator. The oscillator requires various external components.

### 8.3 Oscillator External Connections

In its typical configuration, the oscillator requires five external components. The crystal oscillator is normally connected in a Pierce oscillator configuration, as shown in **Figure 8-1**. This figure shows only the logical representation of the internal components and may not represent actual circuitry. The oscillator configuration uses five components:

- Crystal,  $X_1$
- Fixed capacitor,  $C_1$
- Tuning capacitor,  $C_2$  (can also be a fixed capacitor)
- Feedback resistor,  $R_B$
- Series resistor,  $R_S$  (optional)

The series resistor ( $R_S$ ) is included in the diagram to follow strict Pierce oscillator guidelines and may not be required for all ranges of operation, especially with high frequency crystals. Refer to the crystal manufacturer's data for more information.

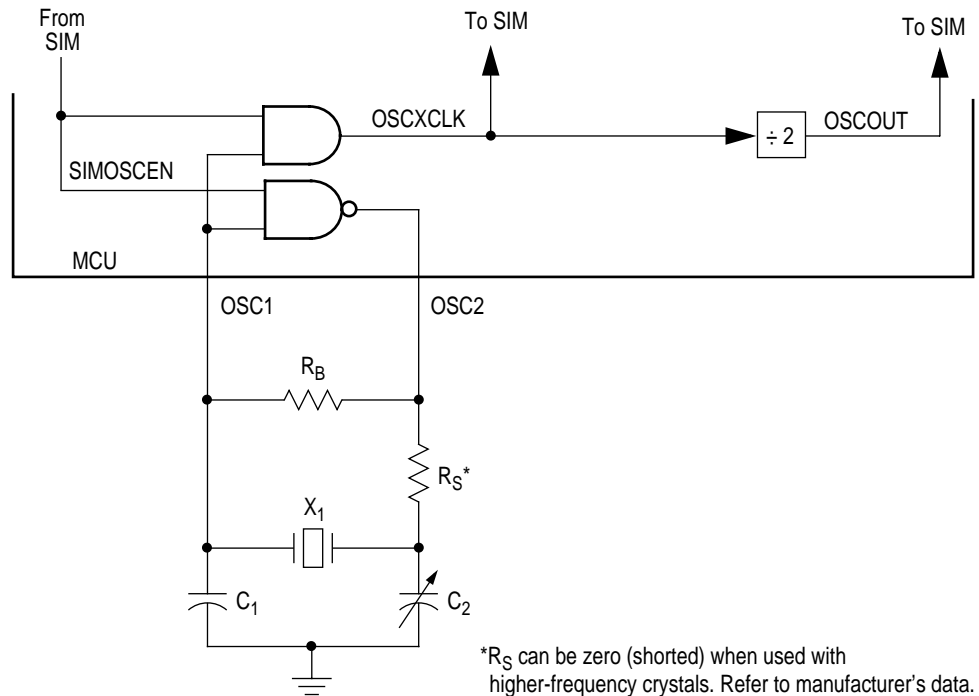

**Figure 8-1. Oscillator External Connections**

## 8.4 I/O Signals

The following paragraphs describe the oscillator I/O signals.

### 8.4.1 Crystal Amplifier Input Pin (OSC1)

The OSC1 pin is an input to the crystal oscillator amplifier.

An externally generated clock can also feed the OSC1 pin of the crystal oscillator circuit. Connect the external clock to the OSC1 pin and let the OSC2 pin float. The OSC1 pin is rated at 3.3V.

### 8.4.2 Crystal Amplifier Output Pin (OSC2)

The OSC2 pin is the output of the crystal oscillator inverting amplifier. The OSC2 is rated at 3.3V.

### 8.4.3 Oscillator Enable Signal (SIMOSCEN)

The SIMOSCEN signal comes from the SIM and enables the oscillator.

### 8.4.4 External Clock Source (OSCXCLK)

OSCXCLK is the crystal oscillator output signal. It runs at the full speed of the crystal ( $f_{XCLK}$ ) and comes directly from the crystal oscillator circuit. **Figure 8-1** shows only the logical relation of OSCXCLK to OSC1 and OSC2 and may not represent the actual circuitry. The duty cycle of OSCXCLK is unknown and may depend on the crystal and other external factors. Also, the frequency and amplitude of OSCXCLK can be unstable at start-up.

### 8.4.5 Oscillator Out (OSCOUT)

The clock driven to the SIM is the crystal frequency divided by two. This signal is driven to the SIM for generation of the bus clocks used by the CPU and other modules on the MCU. OSCOUT will be divided again in the SIM and results in the internal bus frequency being one fourth of the OSCXCLK frequency.

## 8.5 Low Power Modes

The WAIT and STOP instructions put the MCU in low-power-consumption standby modes.

### 8.5.1 Wait Mode

The WAIT instruction has no effect on the oscillator logic. OSCXCLK continues to drive to the SIM module.

### 8.5.2 Stop Mode

The STOP instruction disables the OSCXCLK output.

## 8.6 Oscillator During Break Mode

The oscillator continues drive OSCXCLK when the chip enters the break state.



## Section 9. Monitor ROM (MON)

### 9.1 Contents

9.2	Introduction . . . . .	105
9.3	Features . . . . .	106
9.4	Functional Description . . . . .	106
9.4.1	Entering Monitor Mode . . . . .	108
9.4.2	Data Format . . . . .	109
9.4.3	Echoing . . . . .	110
9.4.4	Break Signal . . . . .	110
9.4.5	Commands . . . . .	111
9.4.6	Baud Rate . . . . .	114

### 9.2 Introduction

This section describes the monitor ROM. The monitor ROM allows complete testing of the MCU through a single-wire interface with a host computer.

### 9.3 Features

Features of the monitor ROM include:

- Normal user-mode pin functionality
- One pin dedicated to serial communication between monitor ROM and host computer
- Standard mark/space non-return-to-zero (NRZ) communication with host computer
- 9600 Baud communication with host computer
- Execution of code in RAM

### 9.4 Functional Description

The monitor ROM receives and executes commands from a host computer. **Figure 9-1** shows a sample circuit used to enter monitor mode and communicate with a host computer via a standard RS-232 interface.

Simple monitor commands can access any memory address. In monitor mode, the MCU can execute host-computer code in RAM while all MCU pins retain normal operating mode functions. All communication between the host computer and the MCU is through the PTA0 pin. A level-shifting and multiplexing interface is required between PTA0 and the host computer. PTA0 is used in a wired-OR configuration and requires a pull-up resistor.

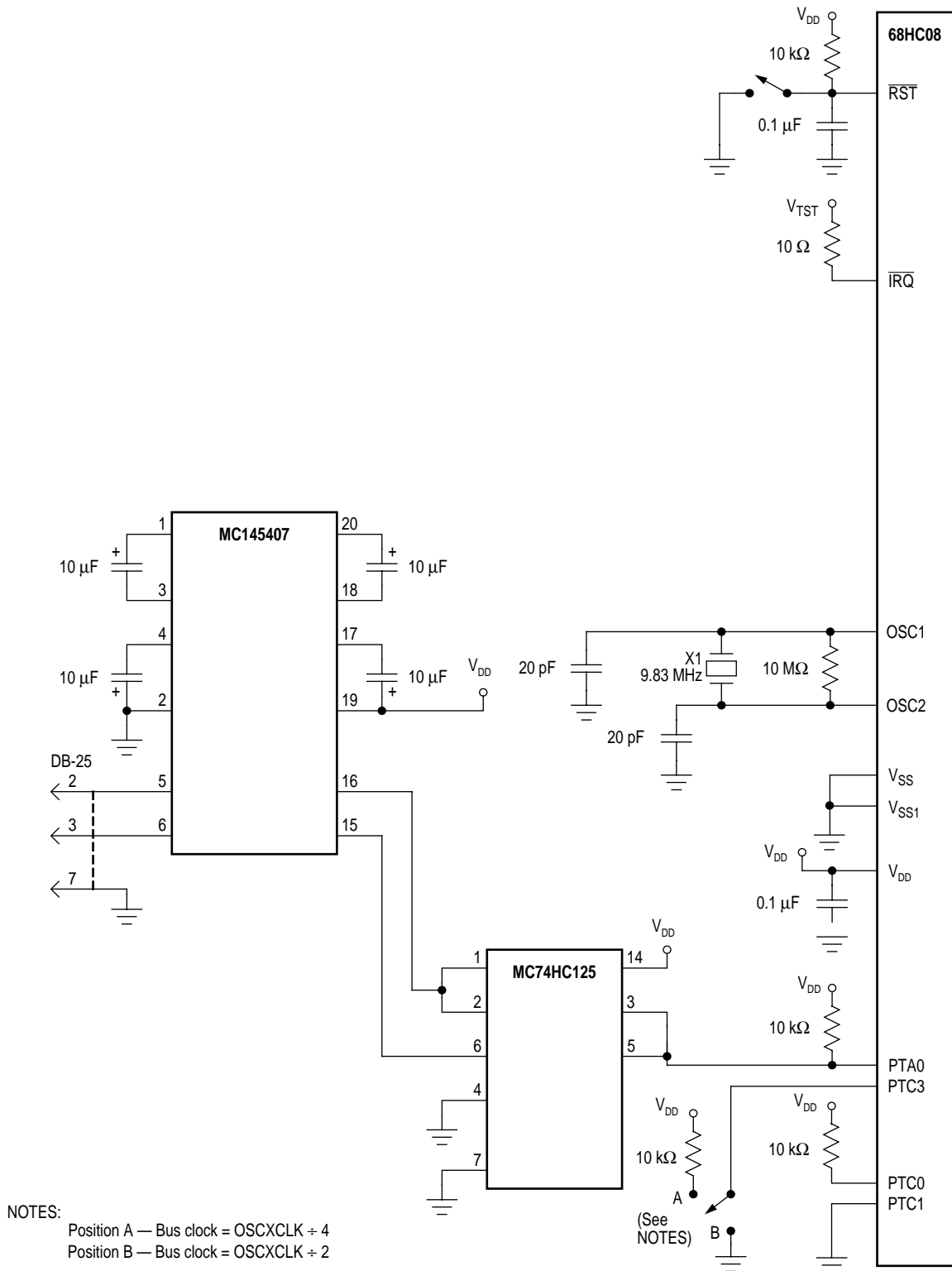

Figure 9-1. Monitor Mode Circuit

9.4.1 Entering Monitor Mode

Table 9-1 shows the pin conditions for entering monitor mode.

Table 9-1. Mode Selection

IRQ Pin	PTC0 Pin	PTC1 Pin	PTA0 Pin	PTC3 Pin	Mode	OSCOUT	Bus Frequency
V <sub>TST</sub>	1	0	1	1	Monitor	$\frac{OSCXCLK}{2}$	$\frac{OSCXCLK}{4}$
V <sub>TST</sub>	1	0	1	0	Monitor	OSCXCLK	$\frac{OSCXCLK}{2}$

**NOTE:** Holding the PTC3 pin low when entering monitor mode causes a bypass of a divide-by-two stage at the oscillator. The OSCOUT frequency is equal to the OSCXCLK frequency, and the OSC1 input directly generates internal bus clocks. In this case, the OSC1 signal must have a 50% duty cycle at maximum bus frequency.

Enter monitor mode with the pin configuration shown above by pulling  $\overline{RST}$  low and then high. The rising edge of  $\overline{RST}$  latches monitor mode. Once monitor mode is latched, the values on the specified pins can change.

Once out of reset, the MCU monitor mode firmware then sends a break signal (10 consecutive logic zeros) to the host computer, indicating that it is ready to receive a command. The break signal also provides a timing reference to allow the host to determine the necessary baud rate.

Monitor mode uses different vectors for reset and SWI. The alternate vectors are in the \$FE page instead of the \$FF page and allow code execution from the internal monitor firmware instead of user code.

When the host computer has completed downloading code into the MCU RAM, This code can be executed by driving PTA0 low while asserting  $\overline{RST}$  low and then high. The internal monitor ROM firmware will interpret the low on PTA0 as an indication to jump to RAM, and execution control will then continue from RAM. Execution of an SWI from the downloaded code will return program control to the internal monitor ROM firmware.

Alternatively, the host can send a RUN command, which executes an RTI, and this can be used to send control to the address on the stack pointer.

The COP module is disabled in monitor mode as long as  $V_{TST}$  is applied to the  $\overline{IRQ}$  or the  $\overline{RST}$  pin. (See [Section 7. System Integration Module \(SIM\)](#) for more information on modes of operation.)

**Table 9-2** is a summary of the differences between user mode and monitor mode.

**Table 9-2. Mode Differences**

Modes	Functions				
	COP	Reset Vector High	Reset Vector Low	SWI Vector High	SWI Vector Low
User	Enabled	\$FFFE	\$FFFF	\$FFFC	\$FFFD
Monitor	Disabled <sup>(1)</sup>	\$FEFE	\$FEFF	\$FEFC	\$FEFD

**Notes:**

1. If the high voltage ( $V_{TST}$ ) is removed from the  $\overline{IRQ}$  pin, the SIM asserts its COP enable output. The COP is a mask option enabled or disabled by the COPD bit in the configuration register.

9.4.2 Data Format

Communication with the monitor ROM is in standard non-return-to-zero (NRZ) mark/space data format. (See [Figure 9-2](#) and [Figure 9-3](#).)

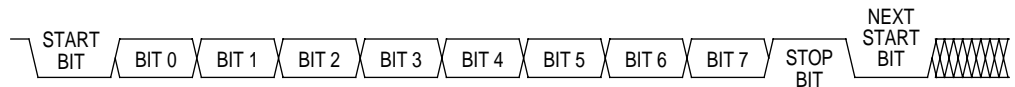

**Figure 9-2. Monitor Data Format**

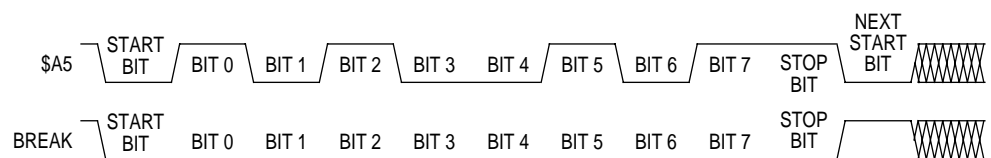
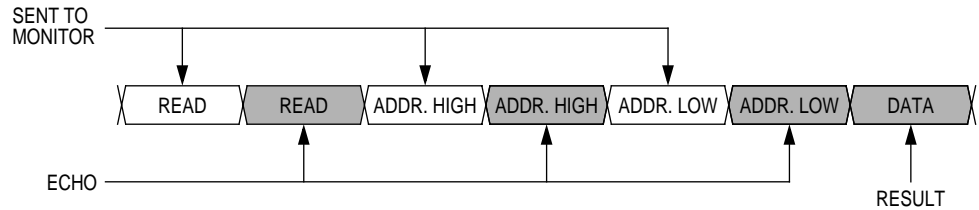

**Figure 9-3. Sample Monitor Waveforms**

The data transmit and receive rate can be anywhere from 4800 baud to 28.8 kbaud. Transmit and receive baud rates must be identical.

### 9.4.3 Echoing

As shown in **Figure 9-4**, the monitor ROM immediately echoes each received byte back to the PTA0 pin for error checking.

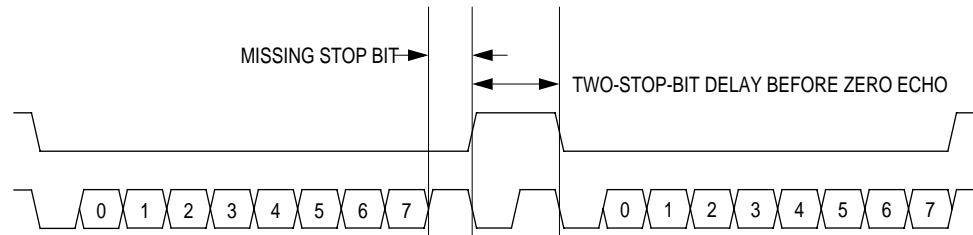

**Figure 9-4. Read Transaction**

Any result of a command appears after the echo of the last byte of the command.

### 9.4.4 Break Signal

A start bit followed by nine low bits is a break signal (see **Figure 9-5**). When the monitor receives a break signal, it drives the PTA0 pin high for the duration of two bits before echoing the break signal.



**Figure 9-5. Break Transaction**

9.4.5 Commands

The monitor ROM uses the following commands:

- READ (read memory)
- WRITE (write memory)
- IREAD (indexed read)
- IWRITE (indexed write)
- READSP (read stack pointer)
- RUN (run user program)

**Table 9-3. READ (Read Memory) Command**

<b>Description</b>	Read byte from memory
<b>Operand</b>	Specifies 2-byte address in high byte:low byte order
<b>Data Returned</b>	Returns contents of specified address
<b>Opcode</b>	\$4A
<b>Command Sequence</b>	
<p>The diagram illustrates the timing of the READ command sequence. It starts with a signal labeled 'SENT TO MONITOR' which points to the first 'READ' signal. This is followed by a second 'READ' signal. Below these two 'READ' signals is an 'ECHO' signal. After the second 'READ' signal, there are two 'ADDRESS HIGH' signals, followed by two 'ADDRESS LOW' signals. Below these address signals is a 'RETURN' signal. The sequence ends with a 'DATA' signal.</p>	

**Table 9-4. WRITE (Write Memory) Command**

<b>Description</b>	Write byte to memory
<b>Operand</b>	Specifies 2-byte address in high byte:low byte order; low byte followed by data byte
<b>Data Returned</b>	None
<b>Opcode</b>	\$49
<b>Command Sequence</b>	

**Table 9-5. IREAD (Indexed Read) Command**

<b>Description</b>	Read Next 2 Bytes in Memory from Last Address Accessed
<b>Operand</b>	Specifies 2-byte address in high byte:low byte order
<b>Data Returned</b>	Returns contents of next two addresses
<b>Opcode</b>	\$1A
<b>Command Sequence</b>	



**Table 9-6. IWRITE (Indexed Write) Command**

<b>Description</b>	Write to last address accessed + 1
<b>Operand</b>	Specifies single data byte
<b>Data Returned</b>	None
<b>Opcode</b>	\$19
<b>Command Sequence</b>	
<p>The diagram shows a sequence of four trapezoidal pulses representing commands and data. The first pulse is labeled 'IWRITE'. An arrow labeled 'SENT TO MONITOR' points to it. The second pulse is also labeled 'IWRITE'. An arrow labeled 'ECHO' points to it. The third pulse is labeled 'DATA'. The fourth pulse is also labeled 'DATA'. An arrow labeled 'ECHO' points to this pulse as well. The sequence is enclosed in a larger trapezoidal shape representing the data stream.</p>	

A sequence of IREAD or IWRITE commands can sequentially access a block of memory over the full 64-kbyte memory map.

**Table 9-7. READSP (Read Stack Pointer) Command**

<b>Description</b>	Reads stack pointer
<b>Operand</b>	None
<b>Data Returned</b>	Returns stack pointer in high byte:low byte order
<b>Opcode</b>	\$0C
<b>Command Sequence</b>	
<p>The diagram shows a sequence of four trapezoidal pulses. The first pulse is labeled 'READSP'. An arrow labeled 'SENT TO MONITOR' points to it. The second pulse is also labeled 'READSP'. An arrow labeled 'ECHO' points to it. The third pulse is labeled 'SP HIGH'. The fourth pulse is labeled 'SP LOW'. An arrow labeled 'RETURN' points to both the 'SP HIGH' and 'SP LOW' pulses. The sequence is enclosed in a larger trapezoidal shape representing the data stream.</p>	

**Table 9-8. RUN (Run User Program) Command**

<b>Description</b>	Executes RTI instruction
<b>Operand</b>	None
<b>Data Returned</b>	None
<b>Opcode</b>	\$28
<p><b>Command Sequence</b></p>	

**9.4.6 Baud Rate**

The communication baud rate is controlled by crystal frequency and the state of the PTC3 pin upon entry into monitor mode. When PTC3 is high, the divide by ratio is 1024. If the PTC3 pin is at logic zero upon entry into monitor mode, the divide by ratio is 512.

**Table 9-9. Monitor Baud Rate Selection**

Crystal Frequency	PTC3 Pin	Baud Rate
19.66 MHz	0	19200 bps
9.83 MHz	0	9600 bps
9.83 MHz	1	4800 bps

## Section 10. Timer Interface Module (TIM)

### 10.1 Contents

10.2	Introduction	116
10.3	Features	116
10.4	Pin Name Conventions	116
10.5	Functional Description	117
10.5.1	TIM Counter Prescaler	119
10.5.2	Input Capture	119
10.5.3	Output Compare	119
10.5.3.1	Unbuffered Output Compare	120
10.5.3.2	Buffered Output Compare	121
10.5.4	Pulse Width Modulation (PWM)	121
10.5.4.1	Unbuffered PWM Signal Generation	122
10.5.4.2	Buffered PWM Signal Generation	123
10.5.4.3	PWM Initialization	124
10.6	Interrupts	125
10.7	Wait Mode	125
10.8	TIM During Break Interrupts	126
10.9	I/O Signals	126
10.10	I/O Registers	127
10.10.1	TIM Status and Control Register (TSC)	127
10.10.2	TIM Counter Registers (TCNTH:TCNTL)	129
10.10.3	TIM Counter Modulo Registers (TMODH:TMODL)	130
10.10.4	TIM Channel Status and Control Registers (TSC0:TSC1)	131
10.10.5	TIM Channel Registers (TCH0H/L:TCH1H/L)	135

## 10.2 Introduction

This section describes the timer interface module (TIM2, Version B). The TIM is a two-channel timer that provides a timing reference with input capture, output compare, and pulse-width-modulation functions. [Figure 10-1](#) is a block diagram of the TIM.

## 10.3 Features

Features of the TIM include the following:

- Two Input Capture/Output Compare Channels
  - Rising-Edge, Falling-Edge, or Any-Edge Input Capture Trigger
  - Set, Clear, or Toggle Output Compare Action
- Buffered and Unbuffered Pulse Width Modulation (PWM) Signal Generation
- Programmable TIM Clock Input
  - Seven-Frequency Internal Bus Clock Prescaler Selection
- Free-Running or Modulo Up-Count Operation
- Toggle Any Channel Pin on Overflow
- TIM Counter Stop and Reset Bits
- Modular Architecture Expandable to Eight Channels

**NOTE:** *TCH1 (timer channel 1) is not bonded to an external pin on this MCU. Therefore, any references to the timer TCH1 pin in the following text should be interpreted as not available — but the internal status and control registers are still available.*

## 10.4 Pin Name Conventions

The TIM share one I/O pin with one port E I/O pin. The full name of the TIM I/O pin is listed in [Table 10-1](#). The generic pin name appear in the text that follows.

**Table 10-1. Pin Name Conventions**

TIM Generic Pin Names:	TCH0	TCH1
Full TIM Pin Names:	PTE0/SOG/TCH0	Not Available

## 10.5 Functional Description

**Figure 10-1** shows the structure of the TIM. The central component of the TIM is the 16-bit TIM counter that can operate as a free-running counter or a modulo up-counter. The TIM counter provides the timing reference for the input capture and output compare functions. The TIM counter modulo registers, TMODH:TMODL, control the modulo value of the TIM counter. Software can read the TIM counter value at any time without affecting the counting sequence.

The two TIM channels are programmable independently as input capture or output compare channels.

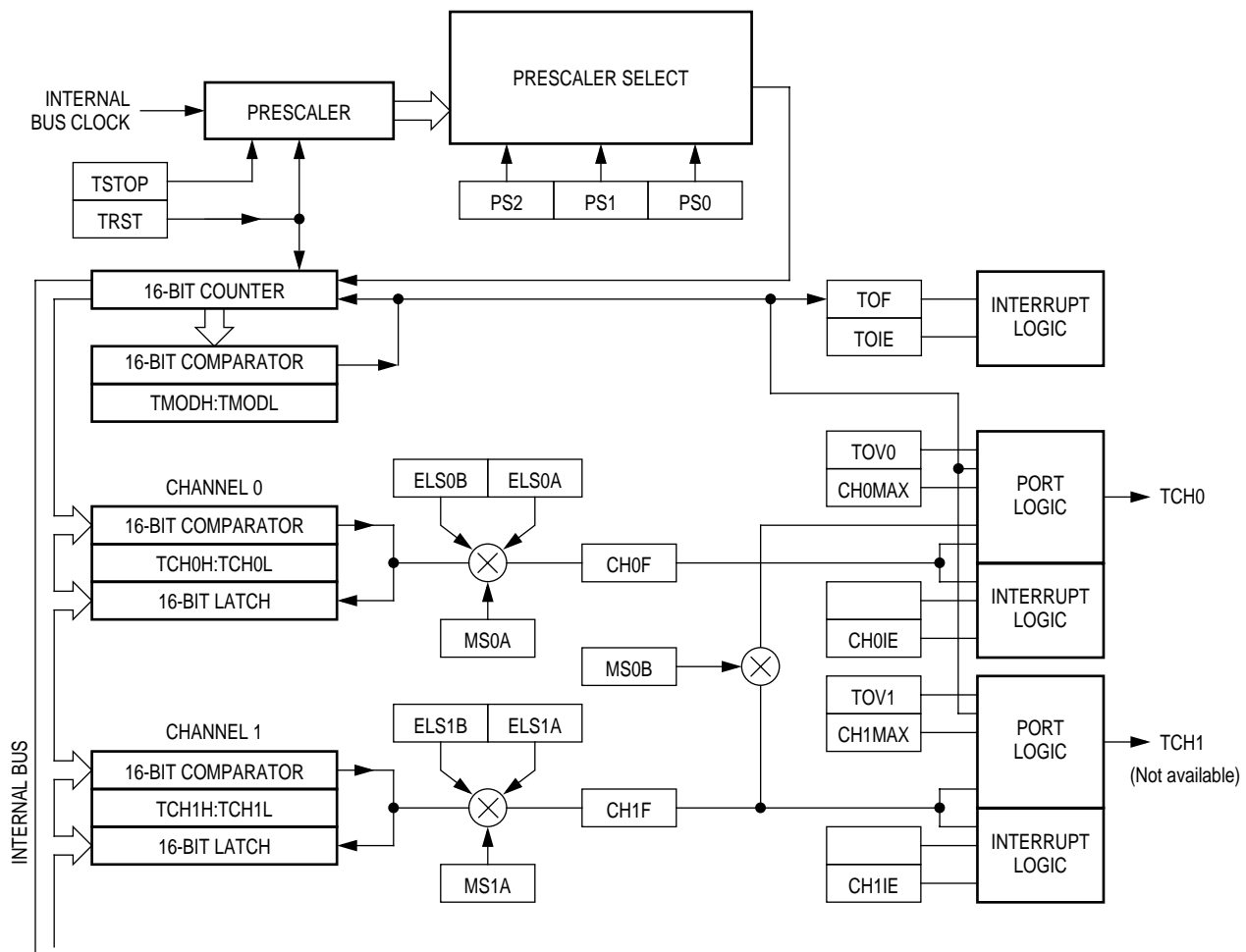

**Figure 10-1. TIM Block Diagram**

Table 10-2. TIM I/O Register Summary

Addr.	Register Name	Bit 7	6	5	4	3	2	1	Bit 0	
\$000A	TIM Status and Control Register (TSC)	Read:	TOF	TOIE	TSTOP	0	0	PS2	PS1	PS0
		Write:	0			TRST				
		Reset:	0	0	1	0	0	0	0	0
\$000C	TIM Counter Register High (TCNTH)	Read:	Bit15	Bit14	Bit13	Bit12	Bit11	Bit10	Bit9	Bit8
		Write:								
		Reset:	0	0	0	0	0	0	0	0
\$000D	TIM Counter Register Low (TCNTL)	Read:	Bit7	Bit6	Bit5	Bit4	Bit3	Bit2	Bit1	Bit0
		Write:								
		Reset:	0	0	0	0	0	0	0	0
\$000E	TIM Counter Modulo Register High (TMODH)	Read:	Bit15	Bit14	Bit13	Bit12	Bit11	Bit10	Bit9	Bit8
		Write:								
		Reset:	1	1	1	1	1	1	1	1
\$000F	TIM Counter Modulo Register Low (TMODL)	Read:	Bit7	Bit6	Bit5	Bit4	Bit3	Bit2	Bit1	Bit0
		Write:								
		Reset:	1	1	1	1	1	1	1	1
\$0010	TIM Channel 0 Status/Control Register (TSC0)	Read:	CH0F	CH0IE	MS0B	MS0A	ELS0B	ELS0A	TOV0	CH0MAX
		Write:	0							
		Reset:	0	0	0	0	0	0	0	0
\$0011	TIM Channel 0 Register High (TCH0H)	Read:	Bit15	Bit14	Bit13	Bit12	Bit11	Bit10	Bit9	Bit8
		Write:								
		Reset:	Indeterminate after reset							
\$0012	TIM Channel 0 Register Low (TCH0L)	Read:	Bit7	Bit6	Bit5	Bit4	Bit3	Bit2	Bit1	Bit0
		Write:								
		Reset:	Indeterminate after reset							
\$0013	TIM Channel 1 Status/Control Register (TSC1)	Read:	CH1F	CH1IE	0	MS1A	ELS1B	ELS1A	TOV1	CH1MAX
		Write:	0							
		Reset:	0	0	0	0	0	0	0	0

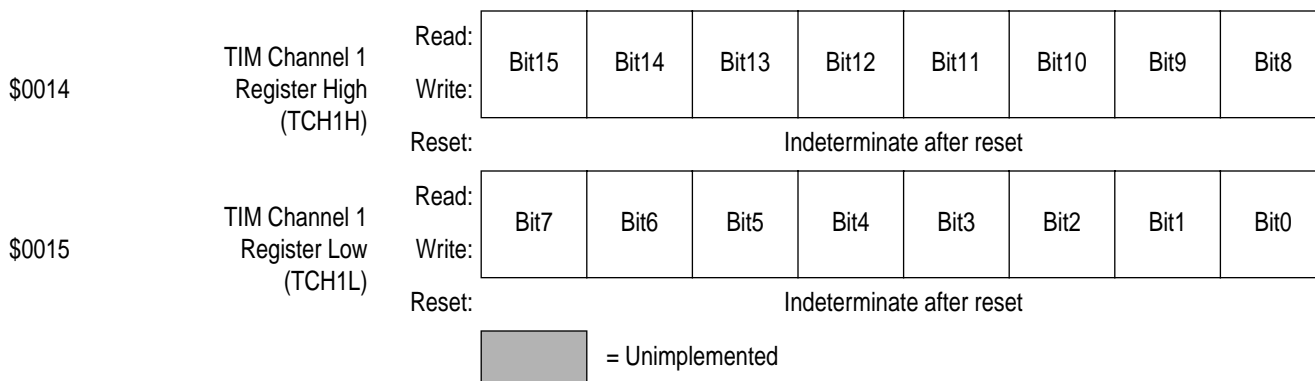

### 10.5.1 TIM Counter Prescaler

The TIM clock source can be one of the seven prescaler outputs. The prescaler generates seven clock rates from the internal bus clock. The prescaler select bits, PS[2:0], in the TIM status and control register (TSC) select the TIM clock source.

### 10.5.2 Input Capture

With the input capture function, the TIM can capture the time at which an external event occurs. When an active edge occurs on the pin of an input capture channel, the TIM latches the contents of the TIM counter into the TIM channel registers, TCHxH:TCHxL. The polarity of the active edge is programmable. Input captures can generate TIM CPU interrupt requests.

### 10.5.3 Output Compare

With the output compare function, the TIM can generate a periodic pulse with a programmable polarity, duration, and frequency. When the counter reaches the value in the registers of an output compare channel, the TIM can set, clear, or toggle the channel pin. Output compares can generate TIM CPU interrupt requests.

### 10.5.3.1 Unbuffered Output Compare

Any output compare channel can generate unbuffered output compare pulses as described in [10.5.3 Output Compare](#). The pulses are unbuffered because changing the output compare value requires writing the new value over the old value currently in the TIM channel registers.

An unsynchronized write to the TIM channel registers to change an output compare value could cause incorrect operation for up to two counter overflow periods. For example, writing a new value before the counter reaches the old value but after the counter reaches the new value prevents any compare during that counter overflow period. Also, using a TIM overflow interrupt routine to write a new, smaller output compare value may cause the compare to be missed. The TIM may pass the new value before it is written.

Use the following methods to synchronize unbuffered changes in the output compare value on channel x:

- When changing to a smaller value, enable channel x output compare interrupts and write the new value in the output compare interrupt routine. The output compare interrupt occurs at the end of the current output compare pulse. The interrupt routine has until the end of the counter overflow period to write the new value.
- When changing to a larger output compare value, enable channel x TIM overflow interrupts and write the new value in the TIM overflow interrupt routine. The TIM overflow interrupt occurs at the end of the current counter overflow period. Writing a larger value in an output compare interrupt routine (at the end of the current pulse) could cause two output compares to occur in the same counter overflow period.



### 10.5.3.2 Buffered Output Compare

Channels 0 and 1 can be linked to form a buffered output compare channel whose output appears on the TCH0 pin. The TIM channel registers of the linked pair alternately control the output.

Setting the MS0B bit in TIM channel 0 status and control register (TSC0) links channel 0 and channel 1. The output compare value in the TIM channel 0 registers initially controls the output on the TCH0 pin. Writing to the TIM channel 1 registers enables the TIM channel 1 registers to synchronously control the output after the TIM overflows. At each subsequent overflow, the TIM channel registers (0 or 1) that control the output are the ones written to last. TSC0 controls and monitors the buffered output compare function, and TIM channel 1 status and control register (TSC1) is unused. While the MS0B bit is set, the channel 1 pin, TCH1, is available as a general-purpose I/O pin.

**NOTE:** *In buffered output compare operation, do not write new output compare values to the currently active channel registers. Writing to the active channel registers is the same as generating unbuffered output compares.*

### 10.5.4 Pulse Width Modulation (PWM)

By using the toggle-on-overflow feature with an output compare channel, the TIM can generate a PWM signal. The value in the TIM counter modulo registers determines the period of the PWM signal. The channel pin toggles when the counter reaches the value in the TIM counter modulo registers. The time between overflows is the period of the PWM signal.

As [Figure 10-2](#) shows, the output compare value in the TIM channel registers determines the pulse width of the PWM signal. The time between overflow and output compare is the pulse width. Program the TIM to clear the channel pin on output compare if the state of the PWM pulse is logic one. Program the TIM to set the pin if the state of the PWM pulse is logic zero.

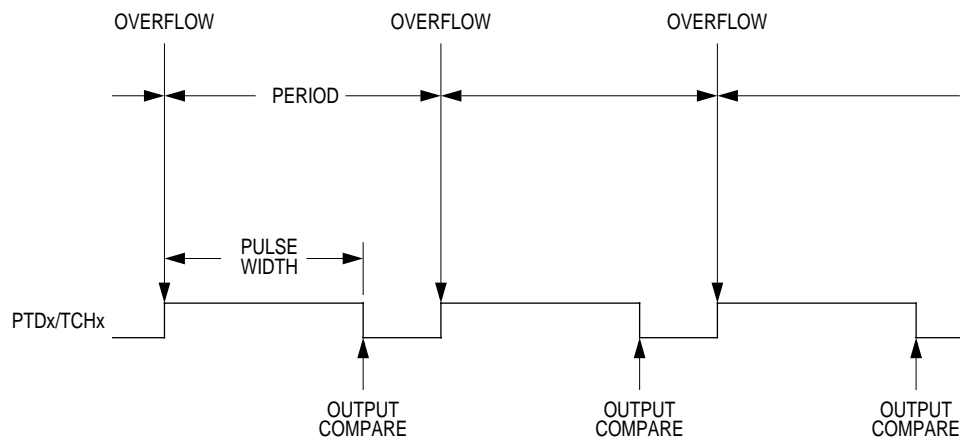

**Figure 10-2. PWM Period and Pulse Width**

The value in the TIM counter modulo registers and the selected prescaler output determines the frequency of the PWM output. The frequency of an 8-bit PWM signal is variable in 256 increments. Writing \$00FF (255) to the TIM counter modulo registers produces a PWM period of 256 times the internal bus clock period if the prescaler select value is 000 (see [10.10.1 TIM Status and Control Register \(TSC\)](#)).

The value in the TIM channel registers determines the pulse width of the PWM output. The pulse width of an 8-bit PWM signal is variable in 256 increments. Writing \$0080 (128) to the TIM channel registers produces a duty cycle of 128/256 or 50%.

#### 10.5.4.1 Unbuffered PWM Signal Generation

Any output compare channel can generate unbuffered PWM pulses as described in [10.5.4 Pulse Width Modulation \(PWM\)](#). The pulses are unbuffered because changing the pulse width requires writing the new pulse width value over the old value currently in the TIM channel registers.

An unsynchronized write to the TIM channel registers to change a pulse width value could cause incorrect operation for up to two PWM periods. For example, writing a new value before the counter reaches the old value but after the counter reaches the new value prevents any compare during that PWM period. Also, using a TIM overflow interrupt routine to

write a new, smaller pulse width value may cause the compare to be missed. The TIM may pass the new value before it is written.

Use the following methods to synchronize unbuffered changes in the PWM pulse width on channel x:

- When changing to a shorter pulse width, enable channel x output compare interrupts and write the new value in the output compare interrupt routine. The output compare interrupt occurs at the end of the current pulse. The interrupt routine has until the end of the PWM period to write the new value.
- When changing to a longer pulse width, enable channel x TIM overflow interrupts and write the new value in the TIM overflow interrupt routine. The TIM overflow interrupt occurs at the end of the current PWM period. Writing a larger value in an output compare interrupt routine (at the end of the current pulse) could cause two output compares to occur in the same PWM period.

**NOTE:** *In PWM signal generation, do not program the PWM channel to toggle on output compare. Toggling on output compare prevents reliable 0% duty cycle generation and removes the ability of the channel to self-correct in the event of software error or noise. Toggling on output compare also can cause incorrect PWM signal generation when changing the PWM pulse width to a new, much larger value.*

#### 10.5.4.2 Buffered PWM Signal Generation

Channels 0 and 1 can be linked to form a buffered PWM channel whose output appears on the TCH0 pin. The TIM channel registers of the linked pair alternately control the pulse width of the output.

Setting the MS0B bit in TIM channel 0 status and control register (TSC0) links channel 0 and channel 1. The TIM channel 0 registers initially control the pulse width on the TCH0 pin. Writing to the TIM channel 1 registers enables the TIM channel 1 registers to synchronously control the pulse width at the beginning of the next PWM period. At each subsequent overflow, the TIM channel registers (0 or 1) that control the pulse width are the ones written to last. TSC0 controls and monitors the buffered PWM function, and TIM channel 1 status and control register

(TSC1) is unused. While the MS0B bit is set, the channel 1 pin, TCH1, is available as a general-purpose I/O pin.

**NOTE:** *In buffered PWM signal generation, do not write new pulse width values to the currently active channel registers. Writing to the active channel registers is the same as generating unbuffered PWM signals.*

#### 10.5.4.3 PWM Initialization

To ensure correct operation when generating unbuffered or buffered PWM signals, use the following initialization procedure:

1. In the TIM status and control register (TSC):
  - a. Stop the TIM counter by setting the TIM stop bit, TSTOP.
  - b. Reset the TIM counter by setting the TIM reset bit, TRST.
2. In the TIM counter modulo registers (TMODH:TMODL), write the value for the required PWM period.
3. In the TIM channel x registers (TCHxH:TCHxL), write the value for the required pulse width.
4. In TIM channel x status and control register (TSCx):
  - a. Write 0:1 (for unbuffered output compare or PWM signals) or 1:0 (for buffered output compare or PWM signals) to the mode select bits, MSxB:MSxA. (See [Table 10-4](#).)
  - b. Write 1 to the toggle-on-overflow bit, TOVx.
  - c. Write 1:0 (to clear output on compare) or 1:1 (to set output on compare) to the edge/level select bits, ELSxB:ELSxA. The output action on compare must force the output to the complement of the pulse width level. (See [Table 10-4](#).)

**NOTE:** *In PWM signal generation, do not program the PWM channel to toggle on output compare. Toggling on output compare prevents reliable 0% duty cycle generation and removes the ability of the channel to self-correct in the event of software error or noise. Toggling on output compare can also cause incorrect PWM signal generation when changing the PWM pulse width to a new, much larger value.*

5. In the TIM status control register (TSC), clear the TIM stop bit, TSTOP.

Setting MS0B links channels 0 and 1 and configures them for buffered PWM operation. The TIM channel 0 registers (TCH0H:TCH0L) initially control the buffered PWM output. TIM status control register 0 (TSCR0) controls and monitors the PWM signal from the linked channels. MS0B takes priority over MS0A.

Clearing the toggle-on-overflow bit, TOVx, inhibits output toggles on TIM overflows. Subsequent output compares try to force the output to a state it is already in and have no effect. The result is a 0% duty cycle output.

Setting the channel x maximum duty cycle bit (CHxMAX) and clearing the TOVx bit generates a 100% duty cycle output. See [10.10.4 TIM Channel Status and Control Registers \(TSC0:TSC1\)](#).

## 10.6 Interrupts

The following TIM sources can generate interrupt requests:

- TIM overflow flag (TOF) — The TOF bit is set when the TIM counter value rolls over to \$0000 after matching the value in the TIM counter modulo registers. The TIM overflow interrupt enable bit, TOIE, enables TIM overflow CPU interrupt requests. TOF and TOIE are in the TIM status and control register.
- TIM channel flags (CH1F:CH0F) — The CHxF bit is set when an input capture or output compare occurs on channel x. Channel x TIM CPU interrupt requests are controlled by the channel x interrupt enable bit, CHxIE. Channel x TIM CPU interrupt requests are enabled when CHxIE=1. CHxF and CHxIE are in the TIM channel x status and control register.

## 10.7 Wait Mode

The WAIT instruction puts the MCU in low-power-consumption standby mode.

The TIM remains active after the execution of a WAIT instruction. In wait mode the TIM registers are not accessible by the CPU. Any enabled CPU interrupt request from the TIM can bring the MCU out of wait mode.

If TIM functions are not required during wait mode, reduce power consumption by stopping the TIM before executing the WAIT instruction.

## 10.8 TIM During Break Interrupts

A break interrupt stops the TIM counter.

The system integration module (SIM) controls whether status bits in other modules can be cleared during the break state. The BCFE bit in the break flag control register (BFCR) enables software to clear status bits during the break state. (See [18.6.4 SIM Break Flag Control Register](#).)

To allow software to clear status bits during a break interrupt, write a logic one to the BCFE bit. If a status bit is cleared during the break state, it remains cleared when the MCU exits the break state.

To protect status bits during the break state, write a logic zero to the BCFE bit. With BCFE at logic zero (its default state), software can read and write I/O registers during the break state without affecting status bits. Some status bits have a two-step read/write clearing procedure. If software does the first step on such a bit before the break, the bit cannot change during the break state as long as BCFE is at logic zero. After the break, doing the second step clears the status bit.

## 10.9 I/O Signals

Port E shares one of its pins with the TIM. The TIM channel I/O pin is PTE0/SOG/TCH0.

TCH0 pin is programmable independently as an input capture pin or an output compare pin. It also can be configured as a buffered output compare or buffered PWM pin.

## 10.10 I/O Registers

The following I/O registers control and monitor operation of the TIM:

- TIM status and control register (TSC)
- TIM control registers (TCNTH:TCNTL)
- TIM counter modulo registers (TMODH:TMODL)
- TIM channel status and control registers (TSC0 and TSC1)
- TIM channel registers (TCH0H:TCH0L and TCH1H:TCH1L)

### 10.10.1 TIM Status and Control Register (TSC)

The TIM status and control register does the following:

- Enables TIM overflow interrupts
- Flags TIM overflows
- Stops the TIM counter
- Resets the TIM counter
- Prescales the TIM counter clock

Address: \$000A

	Bit 7	6	5	4	3	2	1	Bit 0
Read:	TOF	TOIE	TSTOP	0	0	PS2	PS1	PS0
Write:	0			TRST				
Reset:	0	0	1	0	0	0	0	0

 = Unimplemented

**Figure 10-3. TIM Status and Control Register (TSC)**

#### TOF — TIM Overflow Flag Bit

This read/write flag is set when the TIM counter resets to \$0000 after reaching the modulo value programmed in the TIM counter modulo registers. Clear TOF by reading the TIM status and control register when TOF is set and then writing a logic zero to TOF. If another TIM

overflow occurs before the clearing sequence is complete, then writing logic zero to TOF has no effect. Therefore, a TOF interrupt request cannot be lost due to inadvertent clearing of TOF. Reset clears the TOF bit. Writing a logic one to TOF has no effect.

1 = TIM counter has reached modulo value

0 = TIM counter has not reached modulo value

#### TOIE — TIM Overflow Interrupt Enable Bit

This read/write bit enables TIM overflow interrupts when the TOF bit becomes set. Reset clears the TOIE bit.

1 = TIM overflow interrupts enabled

0 = TIM overflow interrupts disabled

#### TSTOP — TIM Stop Bit

This read/write bit stops the TIM counter. Counting resumes when TSTOP is cleared. Reset sets the TSTOP bit, stopping the TIM counter until software clears the TSTOP bit.

1 = TIM counter stopped

0 = TIM counter active

**NOTE:** *Do not set the TSTOP bit before entering wait mode if the TIM is required to exit wait mode.*

#### TRST — TIM Reset Bit

Setting this write-only bit resets the TIM counter and the TIM prescaler. Setting TRST has no effect on any other registers. Counting resumes from \$0000. TRST is cleared automatically after the TIM counter is reset and always reads as logic zero. Reset clears the TRST bit.

1 = Prescaler and TIM counter cleared

0 = No effect

**NOTE:** *Setting the TSTOP and TRST bits simultaneously stops the TIM counter at a value of \$0000.*

#### PS[2:0] — Prescaler Select Bits

These read/write bits select either the TCLK pin or one of the seven prescaler outputs as the input to the TIM counter as [Table 10-3](#) shows. Reset clears the PS[2:0] bits.



Table 10-3. Prescaler Selection

PS2	PS1	PS0	TIM Clock Source
0	0	0	Internal Bus Clock ÷ 1
0	0	1	Internal Bus Clock ÷ 2
0	1	0	Internal Bus Clock ÷ 4
0	1	1	Internal Bus Clock ÷ 8
1	0	0	Internal Bus Clock ÷ 16
1	0	1	Internal Bus Clock ÷ 32
1	1	0	Internal Bus Clock ÷ 64
1	1	1	Not available

### 10.10.2 TIM Counter Registers (TCNTH:TCNTL)

The two read-only TIM counter registers contain the high and low bytes of the value in the TIM counter. Reading the high byte (TCNTH) latches the contents of the low byte (TCNTL) into a buffer. Subsequent reads of TCNTH do not affect the latched TCNTL value until TCNTL is read. Reset clears the TIM counter registers. Setting the TIM reset bit (TRST) also clears the TIM counter registers.

**NOTE:** *If you read TCNTH during a break interrupt, be sure to unlatch TCNTL by reading TCNTL before exiting the break interrupt. Otherwise, TCNTL retains the value latched during the break.*

Timer Interface Module (TIM)

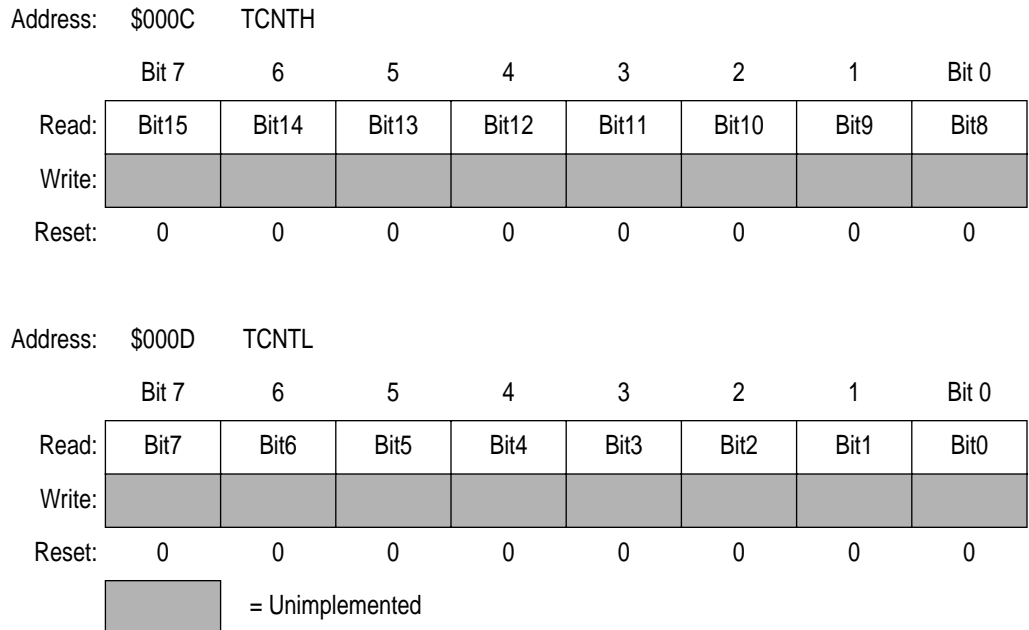

Figure 10-4. TIM Counter Registers (TCNTH:TCNTL)

10.10.3 TIM Counter Modulo Registers (TMODH:TMODL)

The read/write TIM modulo registers contain the modulo value for the TIM counter. When the TIM counter reaches the modulo value, the overflow flag (TOF) becomes set, and the TIM counter resumes counting from \$0000 at the next clock. Writing to the high byte (TMODH) inhibits the TOF bit and overflow interrupts until the low byte (TMODL) is written. Reset sets the TIM counter modulo registers.

Address: \$000E TMODH

	Bit 7	6	5	4	3	2	1	Bit 0
Read:	Bit15	Bit14	Bit13	Bit12	Bit11	Bit10	Bit9	Bit8
Write:								
Reset:	1	1	1	1	1	1	1	1

Address: \$000F TMODL

	Bit 7	6	5	4	3	2	1	Bit 0
Read:	Bit7	Bit6	Bit5	Bit4	Bit3	Bit2	Bit1	Bit0
Write:								
Reset:	1	1	1	1	1	1	1	1

**Figure 10-5. TIM Counter Modulo Registers (TMODH:TMODL)**

**NOTE:** Reset the TIM counter before writing to the TIM counter modulo registers.

#### 10.10.4 TIM Channel Status and Control Registers (TSC0:TSC1)

Each of the TIM channel status and control registers does the following:

- Flags input captures and output compares
- Enables input capture and output compare interrupts
- Selects input capture, output compare, or PWM operation
- Selects high, low, or toggling output on output compare
- Selects rising edge, falling edge, or any edge as the active input capture trigger
- Selects output toggling on TIM overflow
- Selects 100% PWM duty cycle
- Selects buffered or unbuffered output compare/PWM operation

Address:	\$0010	TSC0						
	Bit 7	6	5	4	3	2	1	Bit 0
Read:	CH0F	CH0IE	MS0B	MS0A	ELS0B	ELS0A	TOV0	CH0MAX
Write:	0							
Reset:	0	0	0	0	0	0	0	0

Address:	\$0013	TSC1						
	Bit 7	6	5	4	3	2	1	Bit 0
Read:	CH1F	CH1IE	0	MS1A	ELS1B	ELS1A	TOV1	CH1MAX
Write:	0							
Reset:	0	0	0	0	0	0	0	0

= Unimplemented

**Figure 10-6. TIM Channel Status and Control Registers (TSC0:TSC1)**

**CHxF — Channel x Flag Bit**

When channel x is an input capture channel, this read/write bit is set when an active edge occurs on the channel x pin. When channel x is an output compare channel, CHxF is set when the value in the TIM counter registers matches the value in the TIM channel x registers.

When TIM CPU interrupt requests are enabled (CHxIE=1), clear CHxF by reading the TIM channel x status and control register with CHxF set and then writing a logic zero to CHxF. If another interrupt request occurs before the clearing sequence is complete, then writing logic zero to CHxF has no effect. Therefore, an interrupt request cannot be lost due to inadvertent clearing of CHxF.

Reset clears the CHxF bit. Writing a logic one to CHxF has no effect.

- 1 = Input capture or output compare on channel x
- 0 = No input capture or output compare on channel x

**CHxIE — Channel x Interrupt Enable Bit**

This read/write bit enables TIM CPU interrupt service requests on channel x. Reset clears the CHxIE bit.

- 1 = Channel x CPU interrupt requests enabled
- 0 = Channel x CPU interrupt requests disabled

## MSxB — Mode Select Bit B

This read/write bit selects buffered output compare/PWM operation. MSxB exists only in the TIM channel 0 status and control register.

Setting MS0B disables the channel 1 status and control register and reverts TCH1 to general-purpose I/O.

Reset clears the MSxB bit.

1 = Buffered output compare/PWM operation enabled

0 = Buffered output compare/PWM operation disabled

## MSxA — Mode Select Bit A

When ELSxB:A  $\neq$  00, this read/write bit selects either input capture operation or unbuffered output compare/PWM operation.

See [Table 10-4](#).

1 = Unbuffered output compare/PWM operation

0 = Input capture operation

When ELSxB:A = 00, this read/write bit selects the initial output level of the TCHx pin. (See [Table 10-4](#).) Reset clears the MSxA bit.

1 = Initial output level low

0 = Initial output level high

**NOTE:** *Before changing a channel function by writing to the MSxB or MSxA bit, set the TSTOP and TRST bits in the TIM status and control register (TSC).*

## ELSxB and ELSxA — Edge/Level Select Bits

When channel x is an input capture channel, these read/write bits control the active edge-sensing logic on channel x.

When channel x is an output compare channel, ELSxB and ELSxA control the channel x output behavior when an output compare occurs.

When ELSxB and ELSxA are both clear, channel x is not connected to an I/O port, and pin TCHx is available as a general-purpose port I/O pin. [Table 10-4](#) shows how ELSxB and ELSxA work. Reset clears the ELSxB and ELSxA bits.

Table 10-4. Mode, Edge, and Level Selection

MSxB	MSxA	ELSxB	ELSxA	Mode	Configuration
X	0	0	0	Output Preset	Pin under Port Control; Initial Output Level High
X	1	0	0		Pin under Port Control; Initial Output Level Low
0	0	0	1	Input Capture	Capture on Rising Edge Only
0	0	1	0		Capture on Falling Edge Only
0	0	1	1		Capture on Rising or Falling Edge
0	1	0	1	Output Compare or PWM	Toggle Output on Compare
0	1	1	0		Clear Output on Compare
0	1	1	1		Set Output on Compare
1	X	0	1	Buffered Output Compare or Buffered PWM	Toggle Output on Compare
1	X	1	0		Clear Output on Compare
1	X	1	1		Set Output on Compare

**NOTE:** Before enabling a TIM channel register for input capture operation, make sure that the PTDx/TCHx pin is stable for at least two bus clocks.

TOVx — Toggle-On-Overflow Bit

When channel x is an output compare channel, this read/write bit controls the behavior of the channel x output when the TIM counter overflows. When channel x is an input capture channel, TOVx has no effect. Reset clears the TOVx bit.

1 = Channel x pin toggles on TIM counter overflow.

0 = Channel x pin does not toggle on TIM counter overflow.

**NOTE:** When TOVx is set, a TIM counter overflow takes precedence over a channel x output compare if both occur at the same time.

CHxMAX — Channel x Maximum Duty Cycle Bit

When the TOVx bit is at logic zero, setting the CHxMAX bit forces the duty cycle of buffered and unbuffered PWM signals to 100%. As **Figure 10-7** shows, the CHxMAX bit takes effect in the cycle after it is set or cleared. The output stays at the 100% duty cycle level until the cycle after CHxMAX is cleared.

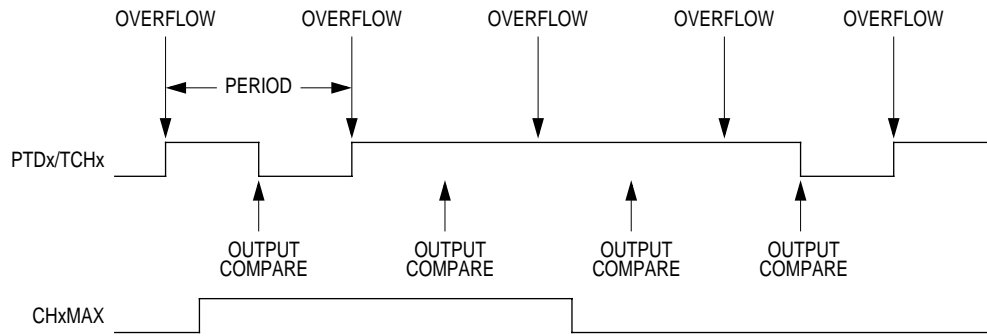

**Figure 10-7. CHxMAX Latency**

### 10.10.5 TIM Channel Registers (TCH0H/L:TCH1H/L)

These read/write registers contain the captured TIM counter value of the input capture function or the output compare value of the output compare function. The state of the TIM channel registers after reset is unknown.

In input capture mode ( $MSxB:MSxA = 0:0$ ), reading the high byte of the TIM channel x registers (TCHxH) inhibits input captures until the low byte (TCHxL) is read.

In output compare mode ( $MSxB:MSxA \neq 0:0$ ), writing to the high byte of the TIM channel x registers (TCHxH) inhibits output compares until the low byte (TCHxL) is written.

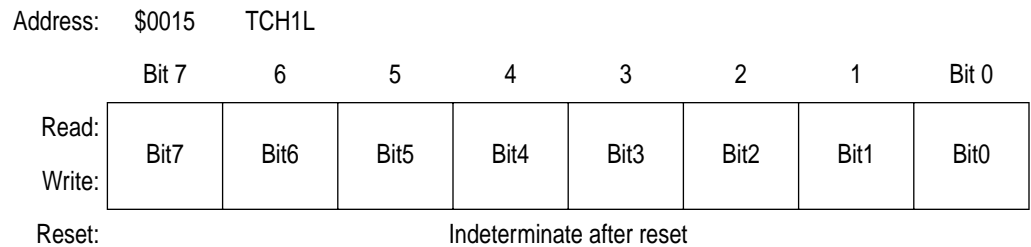
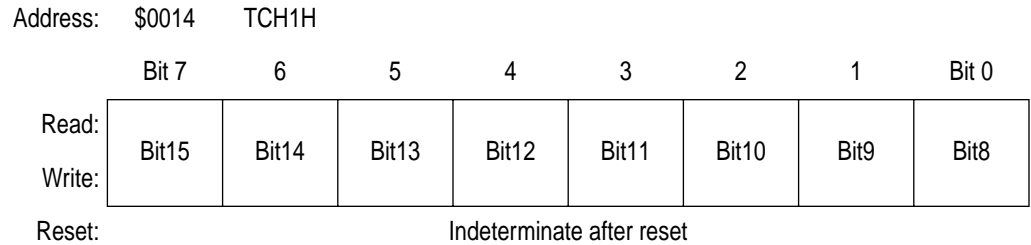
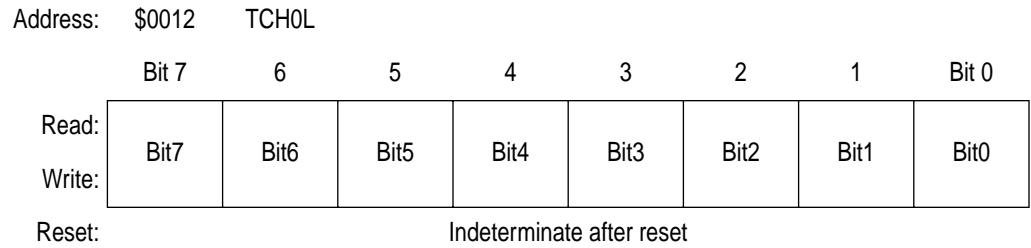
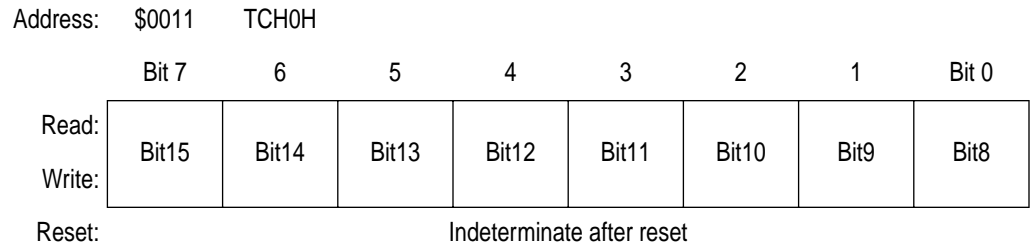

Figure 10-8. TIM Channel Registers (TCH0H/L:TCH1H/L)



## Section 11. Pulse Width Modulator (PWM)

### 11.1 Contents

11.2	Introduction . . . . .	137
11.3	Functional Description . . . . .	137
11.4	PWM Registers . . . . .	139
11.4.1	PWM Data Registers 0 to 15 (0PWM–15PWM) . . . . .	140
11.4.2	PWM Control Registers 1 and 2 (PWMCR1:PWMCR2) . .	141

### 11.2 Introduction

Sixteen 8-bit PWM channels are available on the MC68HC08BD24. Channels 0 to 7 are shared with port-B I/O pins under the control of the PWM control register 1. Channels 8 to 15 are shared with port-A I/O pins under the control of the PWM control register 2.

### 11.3 Functional Description

Each 8-bit PWM channel is composed of an 8-bit register which contains a 5-bit PWM in MSB portion and a 3-bit binary rate multiplier (BRM) in LSB portion. There are 16 PWM data registers as shown in [Table 11-1](#). The value programmed in the 5-bit PWM portion will determine the pulse length of the output. The clock to the 5-bit PWM portion is the system clock, the repetition rate of the output is hence 187.5KHz at 6MHz clock.

The 3-bit BRM will generate a number of narrow pulses which are equally distributed among an 8-PWM-cycle frame. The number of pulses generated is equal to the number programmed in the 3-bit BRM portion. Examples of the waveforms are shown in [Figure 11-3](#).

Pulse Width Modulator (PWM)

Combining the 5-bit PWM together with the 3-bit BRM, the average duty cycle at the output will be  $(M+N/8)/32$ , where M is the content of the 5-bit PWM portion, and N is the content of the 3-bit BRM portion. Using this mechanism, a true 8-bit resolution PWM type DAC with reasonably high repetition rate can be obtained.

The value of each PWM Data Register is continuously compared with the content of an internal counter to determine the state of each PWM channel output pin. Double buffering is not used in this PWM design.

Table 11-1. PWM I/O Register Summary

Addr.	Register Name		Bit 7	6	5	4	3	2	1	Bit 0
\$0020	PWM0 Data Register (0PWM)	Read:	0PWM4	0PWM3	0PWM2	0PWM1	0PWM0	0BRM2	0BRM1	0BRM0
		Write:								
\$0021	PWM1 Data Register (1PWM)	Read:	1PWM4	1PWM3	1PWM2	1PWM1	1PWM0	1BRM2	1BRM1	1BRM0
		Write:								
\$0022	PWM2 Data Register (2PWM)	Read:	2PWM4	2PWM3	2PWM2	2PWM1	2PWM0	2BRM2	2BRM1	2BRM0
		Write:								
\$0023	PWM3 Data Register (3PWM)	Read:	3PWM4	3PWM3	3PWM2	3PWM1	3PWM0	3BRM2	3BRM1	3BRM0
		Write:								
\$0024	PWM4 Data Register (4PWM)	Read:	4PWM4	4PWM3	4PWM2	4PWM1	4PWM0	4BRM2	4BRM1	4BRM0
		Write:								
\$0025	PWM5 Data Register (5PWM)	Read:	5PWM4	5PWM3	5PWM2	5PWM1	5PWM0	5BRM2	5BRM1	5BRM0
		Write:								
\$0026	PWM6 Data Register (6PWM)	Read:	6PWM4	6PWM3	6PWM2	6PWM1	6PWM0	6BRM2	6BRM1	6BRM0
		Write:								
\$0027	PWM7 Data Register (7PWM)	Read:	7PWM4	7PWM3	7PWM2	7PWM1	7PWM0	7BRM2	7BRM1	7BRM0
		Write:								
\$0028	PWM Control Register 1 (PWMCR1)	Read:	PWM7E	PWM6E	PWM5E	PWM4E	PWM3E	PWM2E	PWM1E	PWM0E
		Write:								
Reset:			0	0	0	0	0	0	0	0

**Table 11-1. PWM I/O Register Summary**

\$0051	PWM8 Data Register (8PWM)	Read:	8PWM4	8PWM3	8PWM2	8PWM1	8PWM0	8BRM2	8BRM1	8BRM0
		Write:								
\$0052	PWM9 Data Register (9PWM)	Read:	9PWM4	9PWM3	9PWM2	9PWM1	9PWM0	9BRM2	9BRM1	9BRM0
		Write:								
\$0053	PWM10 Data Register (10PWM)	Read:	10PWM4	10PWM3	10PWM2	10PWM1	10PWM0	10BRM2	10BRM1	10BRM0
		Write:								
\$0054	PWM11 Data Register (11PWM)	Read:	11PWM4	11PWM3	11PWM2	11PWM1	11PWM0	11BRM2	11BRM1	11BRM0
		Write:								
\$0055	PWM12 Data Register (12PWM)	Read:	12PWM4	12PWM3	12PWM2	12PWM1	12PWM0	12BRM2	12BRM1	12BRM0
		Write:								
\$0056	PWM13 Data Register (13PWM)	Read:	13PWM4	13PWM3	13PWM2	13PWM1	13PWM0	13BRM2	13BRM1	13BRM0
		Write:								
\$0057	PWM14 Data Register (14PWM)	Read:	14PWM4	PWM3	14PWM2	14PWM1	14PWM0	14BRM2	14BRM1	14BRM0
		Write:								
\$0058	PWM15 Data Register (15PWM)	Read:	15PWM4	15PWM3	15PWM2	15PWM1	15PWM0	15BRM2	15BRM1	15BRM0
		Write:								
\$0059	PWM Control Register 2 (PWMCR2)	Read:	PWM15E	PWM14E	PWM13E	PWM12E	PWM11E	PWM10E	PWM9E	PWM8E
		Write:								
Reset:			0	0	0	0	0	0	0	0

## 11.4 PWM Registers

The PWM module uses of 18 registers for data and control functions.

- 16 PWM data registers (\$0020–\$0027 and \$0051–\$0058)
- 2 PWM control registers (\$0028 and \$0059)

11.4.1 PWM Data Registers 0 to 15 (0PWM–15PWM)

Address: \$0020–\$0027 and \$0051–\$0058

	Bit 7	6	5	4	3	2	1	Bit 0
Read:	xPWM4	xPWM3	xPWM2	xPWM1	xPWM0	xBRM2	xBRM1	xBRM0
Write:								
Reset:	0	0	0	0	0	0	0	0

**Figure 11-1. PWM Data Registers 0 to 15 (0PWM–15PWM)**

The output waveform of the 16 PWM channels are each configured by an 8-bit register, which contains a 5-bit PWM in MSB portion and a 3-bit binary rate multiplier (BRM) in LSB portion

xPWM4–xPWM0 — PWM Bits

The value programmed in the 5-bit PWM portion will determine the pulse length of the output. The clock to the 5-bit PWM portion is the system clock (CPU clock), the repetition rate of the output is hence  $f_{OP} \div 32$ . Examples of PWM output waveforms are shown in [Figure 11-3](#).

xBRM2–xBRM0 — Binary Rate Multiplier Bits

The 3-bit BRM will generate a number of narrow pulses which are equally distributed among an 8-PWM-cycle frame. The number of pulses generated is equal to the number programmed in the 3-bit BRM portion. Examples of PWM output waveforms are shown in [Figure 11-3](#).

11.4.2 PWM Control Registers 1 and 2 (PWMCR1:PWMCR2)

\$0028	PWM Control Register 1 (PWMCR1)	Read:	PWM7E	PWM6E	PWM5E	PWM4E	PWM3E	PWM2E	PWM1E	PWM0E
		Write:								
\$0059	PWM Control Register 2 (PWMCR2)	Read:	PWM15E	PWM14E	PWM13E	PWM12E	PWM11E	PWM10E	PWM9E	PWM8E
		Write:								
Reset:			0	0	0	0	0	0	0	0

Figure 11-2. PWM Control Register 1 and 2 (PWMCR1:PWMCR2)

PWM15E–PWM0E — PWM Output Enable

Setting a bit to 1 will enable the corresponding PWM channel to use as PWM output. A zero configures the corresponding PWM pin as a standard I/O port pin. Reset clears these bits.

- 1 = Port pin configured as PWM output
- 0 = Port pin configured as standard I/O port pin.

Table 11-2. PWM Channels and Port I/O pins

Port Pin	PWM Channel	Control Bit	Port Pin	PWM Channel	Control Bit
PTB0	PWM0	PWM0E	PTA0	PWM8	PWM8E
PTB1	PWM1	PWM1E	PTA1	PWM9	PWM9E
PTB2	PWM2	PWM2E	PTA2	PWM10	PWM10E
PTB3	PWM3	PWM3E	PTA3	PWM11	PWM11E
PTB4	PWM4	PWM4E	PTA4	PWM12	PWM12E
PTB5	PWM5	PWM5E	PTA5	PWM13	PWM13E
PTB6	PWM6	PWM6E	PTA6	PWM14	PWM14E
PTB7	PWM7	PWM7E	PTA7	PWM15	PWM15E

Pulse Width Modulator (PWM)

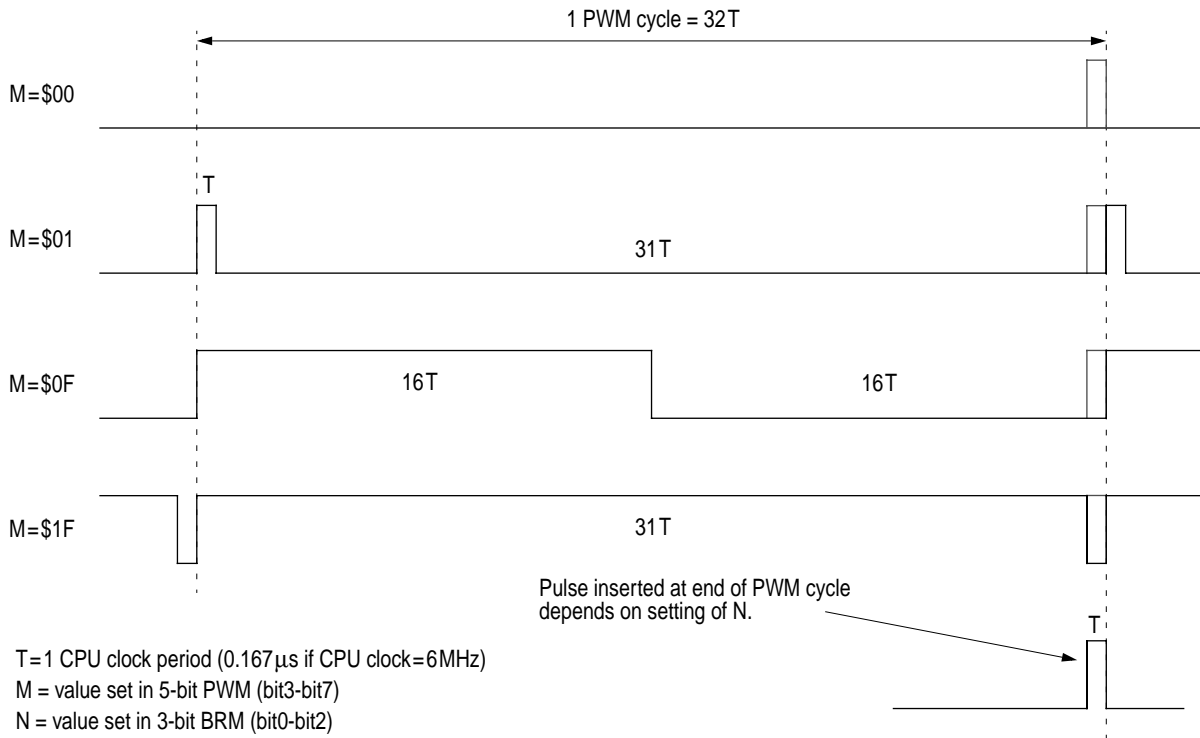

N	PWM cycles where pulses are inserted in a 8-cycle frame	Number of inserted pulses in a 8-cycle frame
xx1	4	1
x1x	2, 6	2
1xx	1, 3, 5, 7	4

Figure 11-3. 8-Bit PWM Output Waveforms

## Section 12. Analog-to-Digital Converter (ADC)

### 12.1 Contents

12.2	Introduction .....	143
12.3	Features .....	144
12.4	Functional Description .....	144
12.4.1	ADC Port I/O Pins .....	145
12.4.2	Voltage Conversion .....	146
12.4.3	Conversion Time .....	146
12.4.4	Continuous Conversion .....	146
12.4.5	Accuracy and Precision .....	147
12.5	Interrupts .....	147
12.6	Low-Power Modes .....	147
12.6.1	Wait Mode .....	147
12.6.2	Stop Mode .....	147
12.7	I/O Signals .....	147
12.7.1	ADC Voltage In (ADCVIN) .....	148
12.8	I/O Registers .....	148
12.8.1	ADC Status and Control Register .....	148
12.8.2	ADC Data Register .....	150
12.8.3	ADC Input Clock Register .....	151

### 12.2 Introduction

This section describes the analog-to-digital converter (ADC). The ADC is an 8-bit 6-channels analog-to-digital converter.

### 12.3 Features

Features of the ADC module include:

- 6 Channels ADC with Multiplexed Input
- Linear Successive Approximation
- 8-Bit Resolution
- Single or Continuous Conversion
- Conversion Complete Flag or Conversion Complete Interrupt
- Selectable ADC Clock

**Table 12-1. ADC Register Summary**

Addr.	Register Name		Bit 7	6	5	4	3	2	1	Bit 0
\$005D	ADC Status and Control Register (ADSCR)	Read:	COCO	AIEN	ADCO	ADCH4	ADCH3	ADCH2	ADCH1	ADCH0
		Write:								
		Reset:	0	0	0	1	1	1	1	1
\$005E	ADC Data Register (ADR)	Read:	AD7	AD6	AD5	AD4	AD3	AD2	AD1	AD0
		Write:								
		Reset:	Indeterminate after Reset							
\$005F	ADC Input Clock Register (ADICLK)	Read:	ADIV2	ADIV1	ADIV0	0	0	0	0	0
		Write:								
		Reset:	0	0	0	0	0	0	0	0

 = Unimplemented

### 12.4 Functional Description

Four ADC channels are available for sampling external sources at pins PTC5–PTC0. An analog multiplexer allows the single ADC converter to select one of the 6 ADC channels as ADC voltage input (ADCVIN). ADCVIN is converted by the successive approximation register-based counters. The ADC resolution is 8 bits. When the conversion is completed, ADC puts the result in the ADC data register and sets a flag or generates an interrupt. **Figure 12-1** shows a block diagram of the ADC.



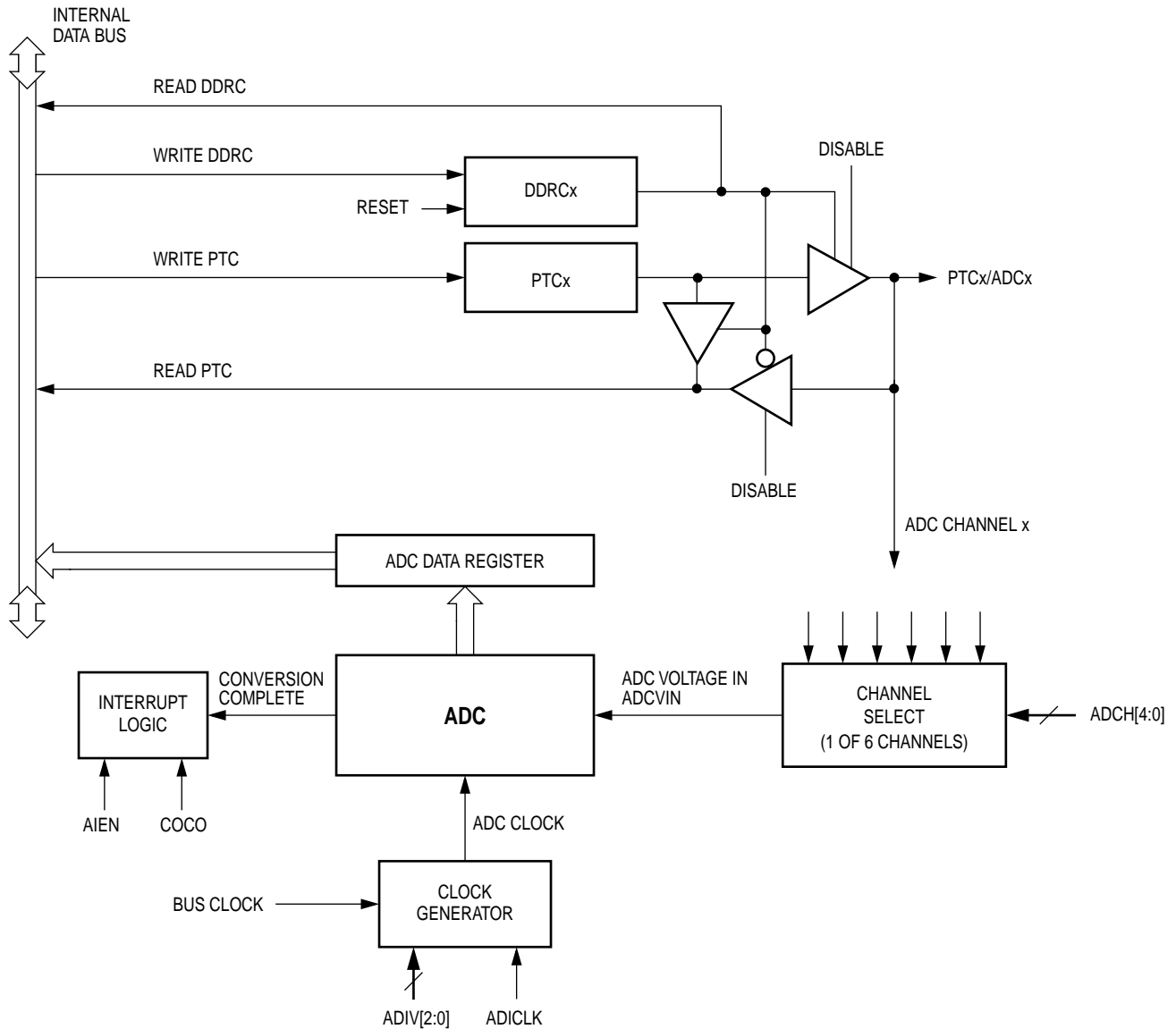

Figure 12-1. ADC Block Diagram

### 12.4.1 ADC Port I/O Pins

PTC5–PTC0 are general-purpose I/O pins that are shared with the ADC channels. The channel select bits (ADC status control register, \$005D), define which ADC channel/port pin will be used as the input signal. The ADC overrides the port I/O logic by forcing that pin as input to the ADC. The remaining ADC channels/port pins are controlled by the port I/O logic and can be used as general-purpose I/O. Writes to the port register

or DDR will not have any affect on the port pin that is selected by the ADC. Read of a port pin which is in use by the ADC will return an unknown state if the corresponding DDR bit is at logic 0. If the DDR bit is at logic 1, the value in the port data latch is read.

#### 12.4.2 Voltage Conversion

When the input voltage to the ADC equals  $\frac{2}{3} V_{DD}$ , the ADC converts the signal to \$FF (full scale). If the input voltage equals  $V_{SS}$ , the ADC converts it to \$00. Input voltage between  $\frac{2}{3} V_{DD}$  and  $V_{SS}$  are a straight-line linear conversion. All other input voltages will result in \$FF if greater than  $\frac{2}{3} V_{DD}$  and \$00 if less than  $V_{SS}$ .

**NOTE:** *Input voltage should not exceed the analog supply voltages.*

#### 12.4.3 Conversion Time

Twelve ADC internal clocks are required to perform one conversion. The ADC starts a conversion on the first rising edge of the ADC internal clock immediately following a write to the ADSCR. If the ADC internal clock is selected to run at 1 MHz, then one conversion will take 12 $\mu$ s to complete. With a 1 MHz ADC internal clock the maximum sample rate is 83.3 kHz.

$$\text{Conversion Time} = \frac{12 \text{ ADC Clock Cycles}}{\text{ADC Clock Frequency}}$$

$$\text{Number of Bus Cycles} = \text{Conversion Time} \times \text{Bus Frequency}$$

#### 12.4.4 Continuous Conversion

In the continuous conversion mode, the ADC continuously converts the selected channel filling the ADC data register with new data after each conversion. Data from the previous conversion will be overwritten whether that data has been read or not. Conversions will continue until the ADCO bit is cleared. The COCO bit (ADC status control register, \$005D) is set after each conversion and can be cleared by writing the ADC status and control register or reading of the ADC data register.

### 12.4.5 Accuracy and Precision

The conversion process is monotonic and has no missing codes.

## 12.5 Interrupts

When the AIEN bit is set, the ADC module is capable of generating a CPU interrupt after each ADC conversion. A CPU interrupt is generated if the COCO bit is at logic 0. The COCO bit is not used as a conversion complete flag when interrupts are enabled.

## 12.6 Low-Power Modes

The following subsections describe the low-power modes.

### 12.6.1 Wait Mode

The ADC continues normal operation during wait mode. Any enabled CPU interrupt request from the ADC can bring the MCU out of wait mode. If the ADC is not required to bring the MCU out of wait mode, power down the ADC by setting the ADCH[4:0] bits in the ADC status and control register to logic 1's before executing the WAIT instruction.

### 12.6.2 Stop Mode

The ADC module is inactive after the execution of a STOP instruction. Any pending conversion is aborted. ADC conversions resume when the MCU exits stop mode. Allow one conversion cycle to stabilize the analog circuitry before attempting a new ADC conversion after exiting stop mode.

## 12.7 I/O Signals

The ADC module has 6 channels that are shared with I/O port C.

12.7.1 ADC Voltage In (ADCVIN)

ADCVIN is the input voltage signal from one of the 6 ADC channels to the ADC module.

12.8 I/O Registers

Three I/O registers control and monitor ADC operation:

- ADC status and control register (ADSCR, \$005D)
- ADC data register (ADR, \$005E)
- ADC clock register (ADICLK, \$005F)

12.8.1 ADC Status and Control Register

The following paragraphs describe the function of the ADC status and control register.

Address: \$005D

	Bit 7	6	5	4	3	2	1	Bit 0
Read:	COCO	AIEN	ADCO	ADCH4	ADCH3	ADCH2	ADCH1	ADCH0
Write:								
Reset:	0	0	0	1	1	1	1	1

 = Unimplemented

**Figure 12-2. ADC Status and Control Register (ADSCR)**

COCO — Conversions Complete Bit

When the AIEN bit is a logic 0, the COCO is a read-only bit which is set each time a conversion is completed. This bit is cleared whenever the ADC status and control register is written or whenever the ADC data register is read. Reset clears this bit.

- 1 = conversion completed (AIEN = 0)
- 0 = conversion not completed (AIEN = 0)

When the AIEN bit is a logic 1 (CPU interrupt enabled), the COCO is a read-only bit, and will always be logic 0 when read.

## AIEN — ADC Interrupt Enable Bit

When this bit is set, an interrupt is generated at the end of an ADC conversion. The interrupt signal is cleared when the data register is read or the status/control register is written. Reset clears the AIEN bit.

- 1 = ADC interrupt enabled
- 0 = ADC interrupt disabled

## ADCO — ADC Continuous Conversion Bit

When set, the ADC will convert samples continuously and update the ADR register at the end of each conversion. Only one conversion is allowed when this bit is cleared. Reset clears the ADCO bit.

- 1 = Continuous ADC conversion
- 0 = One ADC conversion

## ADCH[4:0] — ADC Channel Select Bits

ADCH[4:0] form a 5-bit field which is used to select one of the ADC channels. The five channel select bits are detailed in the following table. Care should be taken when using a port pin as both an analog and a digital input simultaneously to prevent switching noise from corrupting the analog signal. (See [Table 12-2](#).)

The ADC subsystem is turned off when the channel select bits are all set to one. This feature allows for reduced power consumption for the MCU when the ADC is not used. Reset sets all of these bits to a logic 1.

**NOTE:** *Recovery from the disabled state requires one conversion cycle to stabilize.*

Table 12-2. MUX Channel Select

ADCH4	ADCH3	ADCH2	ADCH1	ADCH0	ADC Channel	Input Select
0	0	0	0	0	ADC0	PTC0
0	0	0	0	1	ADC1	PTC1
0	0	0	1	0	ADC2	PTC2
0	0	0	1	1	ADC3	PTC3
0	0	1	0	0	ADC4	PTC4
0	0	1	0	1	ADC5	PTC5
0	0	1	1	0	—	Unused (see Note 1)
:	:	:	:	:	—	
1	1	0	1	0	—	Reserved
1	1	0	1	1	—	Reserved
1	1	1	0	0	—	Unused
1	1	1	0	1		V <sub>DDA</sub> (see Note 2)
1	1	1	1	0		V <sub>SSA</sub> (see Note 2)
1	1	1	1	1		ADC power off

NOTES:

1. If any unused channels are selected, the resulting ADC conversion will be unknown.
2. The voltage levels supplied from internal reference nodes as specified in the table are used to verify the operation of the ADC converter both in production test and for user applications.

12.8.2 ADC Data Register

One 8-bit result register is provided. This register is updated each time an ADC conversion completes.

Address: \$005E

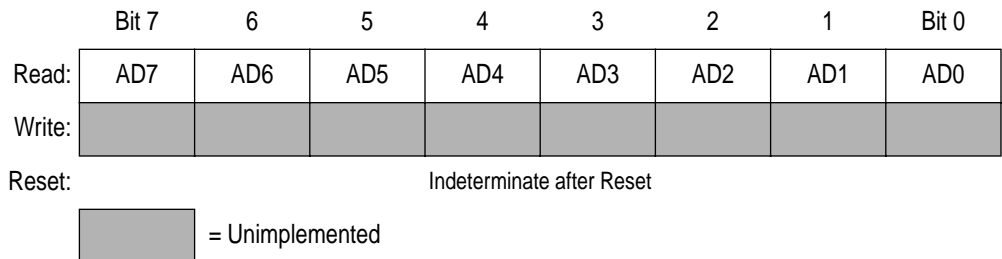
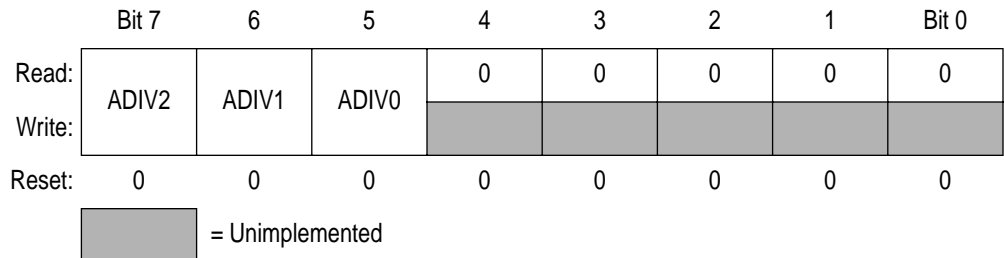

Figure 12-3. ADC Data Register (ADR)

12.8.3 ADC Input Clock Register

This register selects the clock frequency for the ADC.

Address: \$005F



**Figure 12-4. ADC Input Clock Register (ADICLK)**

ADIV2:ADIV0 — ADC Clock Prescaler Bits

ADIV2, ADIV1, and ADIV0 form a 3-bit field which selects the divide ratio used by the ADC to generate the internal ADC clock. [Table 12-3](#) shows the available clock configurations. The ADC clock should be set to approximately 1 MHz. With an internal bus frequency of 6MHz, set ADIV[2:0] = 010, for a divide by four ADC clock rate.

**Table 12-3. ADC Clock Divide Ratio**

ADIV2	ADIV1	ADIV0	ADC Clock Rate
0	0	0	Internal bus clock ÷ 1
0	0	1	Internal bus clock ÷ 2
0	1	0	Internal bus clock ÷ 4
0	1	1	Internal bus clock ÷ 8
1	X	X	Internal bus clock ÷ 16

X = don't care





## Section 13. DDC12AB Interface

### 13.1 Contents

13.2	Introduction .....	153
13.3	Features .....	154
13.4	I/O Pins .....	154
13.5	DDC Protocols .....	156
13.6	Registers .....	156
13.6.1	DDC Address Register (DADR) .....	156
13.6.2	DDC2 Address Register (D2ADR) .....	157
13.6.3	DDC Control Register (DCR) .....	158
13.6.4	DDC Master Control Register (DMCR) .....	159
13.6.5	DDC Status Register (DSR) .....	162
13.6.6	DDC Data Transmit Register (DDTR) .....	164
13.6.7	DDC Data Receive Register (DDRR) .....	165
13.7	Programming Considerations .....	166

### 13.2 Introduction

This DDC12AB Interface module is used by the digital monitor to show its identification information to the video controller. It contains DDC1 hardware and a two-wire, bidirectional serial bus which is fully compatible with multi-master IIC bus protocol to support DDC2AB interface.

This module not only can be applied in internal communications, but can also be used as a typical command reception serial bus for factory setup and alignment purposes. It also provides the flexibility of hooking additional devices to an existing system for future expansion without adding extra hardware.

This DDC12AB module uses the DDCSCL clock line and the DDCSDA data line to communicate with external DDC host or IIC interface. These two pins are shared with port pins PTD3 and PTD2 respectively. The outputs of DDCSDA and DDCSCL pins are open-drain type — no clamping diode is connected between the pin and internal  $V_{DD}$ . The maximum data rate typically is 100k-bps. The maximum communication length and the number of devices that can be connected are limited by a maximum bus capacitance of 400pF.

### 13.3 Features

- DDC1 hardware
- Compatibility with multi-master IIC bus standard
- Software controllable acknowledge bit generation
- Interrupt driven byte by byte data transfer
- Calling address identification interrupt
- Auto detection of R/W bit and switching of transmit or receive mode
- Detection of START, repeated START, and STOP signals
- Auto generation of START and STOP condition in master mode
- Arbitration loss detection and No-ACK awareness in master mode
- 8 selectable baud rate master clocks
- Automatic recognition of the received acknowledge bit

### 13.4 I/O Pins

The DDC12AB module uses two I/O pins, shared with standard port I/O pins. The full name of the DDC12AB I/O pins are listed in [Table 13-1](#). The generic pin name appear in the text that follows.

**Table 13-1. Pin Name Conventions**

DDC12AB Generic Pin Names:	Full MCU Pin Names:	Pin Selected for DDC Function By:
SDA	PTD2/DDCSDA	DDCDATE bit in PDCR (\$0049)
SCL	PTD3/DDCSCL	DDCSCLE bit in PDCR (\$0049)

Table 13-2. DDC I/O Register Summary

Addr.	Register Name	Bit 7	6	5	4	3	2	1	Bit 0	
\$0016	DDC Master Control Register (DMCR)	Read:	ALIF	NAKIF	BB	MAST	MRW	BR2	BR1	BR0
		Write:								
		Reset:	0	0	0	0	0	0	0	0
\$0017	DDC Address Register (DADR)	Read:	DAD7	DAD6	DAD5	DAD4	DAD3	DAD2	DAD1	EXTAD
		Write:								
		Reset:	1	0	1	0	0	0	0	0
\$0018	DDC Control Register (DCR)	Read:	DEN	DIEN	0	0	TXAK	SCLIEN	DDC1EN	0
		Write:								
		Reset:	0	0	0	0	0	0	0	0
\$0019	DDC Status Register (DSR)	Read:	RXIF	TXIF	MATCH	SRW	RXAK	SCLIF	TXBE	RXBF
		Write:	0	0				0		
		Reset:	0	0	0	0	1	0	1	0
\$001A	DDC Data Transmit Register (DDTR)	Read:	DTD7	DTD6	DTD5	DTD4	DTD3	DTD2	DTD1	DTD0
		Write:								
		Reset:	1	1	1	1	1	1	1	1
\$001B	DDC Data Receive Register (DDRR)	Read:	DRD7	DRD6	DRD5	DRD4	DRD3	DRD2	DRD1	DRD0
		Write:								
		Reset:	0	0	0	0	0	0	0	0
\$001C	DDC2 Address Register (D2ADR)	Read:	D2AD7	D2AD6	D2AD5	D2AD4	D2AD3	D2AD2	D2AD1	0
		Write:								
		Reset:	0	0	0	0	0	0	0	0

 = Unimplemented

### 13.5 DDC Protocols

In DDC1 protocol communication, the module is in transmit mode. The data written to the transmit register is continuously clocked out to the SDA line by the rising edge of the Vsync input signal. During DDC1 communication, a falling transition on the SCL line can be detected to generate an interrupt to the CPU for mode switching.

In DDC2AB protocol communication, the module can be either in transmit mode or in receive mode, controlled by the calling master.

In DDC2 protocol communication, the module will act as a standard IIC module, able to act as a master or a slave device.

### 13.6 Registers

Seven registers are associated with the DDC module, they outlined in the following sections.

#### 13.6.1 DDC Address Register (DADR)

Address: \$0017

	Bit 7	6	5	4	3	2	1	Bit 0
Read:	DAD7	DAD6	DAD5	DAD4	DAD3	DAD2	DAD1	EXTAD
Write:								
Reset:	1	0	1	0	0	0	0	0

**Figure 13-1. DDC Address Register (DADR)**

#### DAD[7:1] — DDC Address

These 7 bits can be the DDC2 interface's own specific slave address in slave mode or the calling address when in master mode. Reset sets a default value of \$A0.

EXTAD — DDC Expanded Address

This bit is set to expand the calling address of the DDC in slave mode. When set, the DDC will acknowledge the general call address \$00 and the matched 4-bit MSB address, DAD[7:4].

For example, when DAD[7:1] = \$A1 and EXTAD = 1, the DDC calling address is \$A0, and it will acknowledge calling addresses \$00 and \$A0 to \$AF.

Reset clears this bit.

1 = DDC calling address is \$DAD[7:4]0

DDC respond address is \$00, and \$DAD[7:4]0 to \$DAD[7:4]F

0 = DDC address id \$DAD[7:1]

13.6.2 DDC2 Address Register (D2ADR)

Address: \$001C

	Bit 7	6	5	4	3	2	1	Bit 0
Read:	D2AD7	D2AD6	D2AD5	D2AD4	D2AD3	D2AD2	D2AD1	0
Write:								
Reset:	0	0	0	0	0	0	0	0

Figure 13-2. DDC2 Address Register (D2ADR)

D2AD[7:1] — DDC2 Address

These 7 bits represent the second slave address for the DDC2BI protocol. D2AD[7:1] should be set to the same value as DAD[7:1] in DADR if user application do not use DDC2BI. Reset clears all bits this register.

13.6.3 DDC Control Register (DCR)

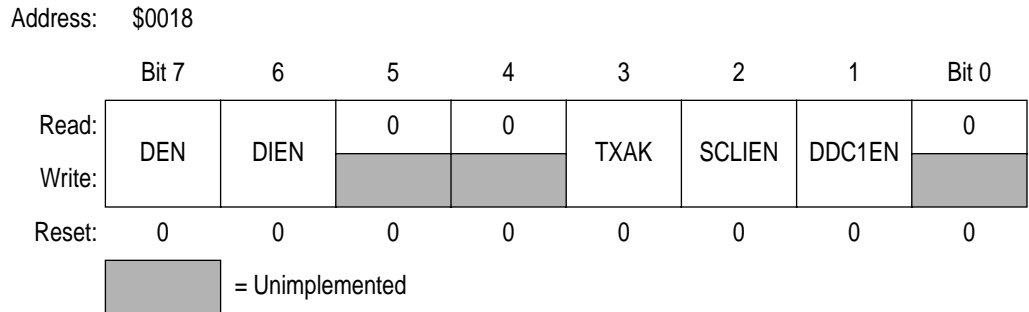

Figure 13-3. DDC Control Register (DCR)

DEN — DDC Enable

This bit is set to enable the DDC module. When DEN = 0, module is disabled and all flags will restore to its power-on default states. Reset clears this bit.

- 1 = DDC module enabled
- 0 = DDC module disabled

DIEN — DDC Interrupt Enable

When this bit is set, the TXIF, RXIF, ALIF, and NAKIF flags are enabled to generate an interrupt request to the CPU. When DIEN is cleared, the these flags are prevented from generating an interrupt request. Reset clears this bit.

- 1 = TXIF, RXIF, ALIF, and/or NAKIF bit set will generate interrupt request to CPU
- 0 = TXIF, RXIF, ALIF, and/or NAKIF bit set will not generate interrupt request to CPU

TXAK — Transmit Acknowledge Enable

This bit is set to disable the DDC from sending out an acknowledge signal to the bus at the 9th clock bit after receiving 8 data bits. When TXAK is cleared, an acknowledge signal will be sent at the 9th clock bit. Reset clears this bit.

- 1 = DDC does not send acknowledge signals at 9th clock bit
- 0 = DDC sends acknowledge signal at 9th clock bit

SCLIEN — SCL Interrupt Enable

When this bit is set, the SCLIF flag is enabled to generate an interrupt request to the CPU. When SCLIEN is cleared, SCLIF is prevented from generating an interrupt request. Reset clears this bit.

- 1 = SCLIF bit set will generate interrupt request to CPU
- 0 = SCLIF bit set will not generate interrupt request to CPU

DDC1EN — DDC1 Protocol Enable

This bit is set to enable DDC1 protocol. The DDC1 protocol will use the Vsync input (from sync processor) as the master clock input to the DDC module. Vsync rising-edge will continuously clock out the data to the output circuit. No calling address comparison is performed. The SRW bit in DDC status register (DSR) will always read as "1". Reset clears this bit.

- 1 = DDC1 protocol enabled
- 0 = DDC1 protocol disabled

13.6.4 DDC Master Control Register (DMCR)

Address: \$0016

	Bit 7	6	5	4	3	2	1	Bit 0
Read:	ALIF	NAKIF	BB	MAST	MRW	BR2	BR1	BR0
Write:								
Reset:	0	0	0	0	0	0	0	0

Figure 13-4. DDC Master Control Register (DMCR)

ALIF — DDC Arbitration Lost Interrupt Flag

The flag is set when software attempt to set MAST but the BB has been set by detecting the start condition on the lines or when the DDC is transmitting a "1" to SDA line but detected a "0" from SDA line in master mode – an arbitration loss. This bit generates an interrupt request to the CPU if the DIEN bit in DCR is also set. This bit is cleared by writing "0" to it or by reset.

- 1 = Lost arbitration in master mode
- 0 = No arbitration lost

**NAKIF** — No Acknowledge Interrupt Flag

The flag is only set in master mode (MAST = 1) when there is no acknowledge bit detected after one data byte or calling address is transferred. This flag also clears MAST. NAKIF generates an interrupt request to CPU if the DIEN bit in DCR is also set. This bit is cleared by writing "0" to it or by reset.

- 1 = No acknowledge bit detected
- 0 = Acknowledge bit detected

**BB** — Bus Busy Flag

This flag is set after a start condition is detected (bus busy), and is cleared when a stop condition (bus idle) is detected or the DDC is disabled. Reset clears this bit.

- 1 = Start condition detected
- 0 = Stop condition detected or DDC is disabled

**MAST** — Master Control Bit

This bit is set to initiate a master mode transfer. In master mode, the module generates a start condition to the SDA and SCL lines, followed by sending the calling address stored in DADR.

When the MAST bit is cleared by NAKIF set (no acknowledge) or by software, the module generates the stop condition to the lines after the current byte is transmitted.

If an arbitration loss occurs (ALIF = 1), the module reverts to slave mode by clearing MAST, and releasing SDA and SCL lines immediately.

This bit is cleared by writing "0" to it or by reset.

- 1 = Master mode operation
- 0 = Slave mode operation

**MRW** — Master Read/Write

This bit will be transmitted out as bit 0 of the calling address when the module sets the MAST bit to enter master mode. The MRW bit determines the transfer direction of the data bytes that follows. When it is "1", the module is in master receive mode. When it is "0", the module is in master transmit mode. Reset clears this bit.

- 1 = Master mode receive
- 0 = Master mode transmit



**BR2–BR0 — Baud Rate Select**

These three bits select one of eight clock rates as the master clock when the module is in master mode.

Since this master clock is derived the CPU bus clock, the user program should not execute the WAIT instruction when the DDC module in master mode. This will cause the SDA and SCL lines to hang, as the WAIT instruction places the MCU in WAIT mode, with CPU clock is halted. These bits are cleared upon reset. (See [Table 13-3 . Baud Rate Select.](#))

**Table 13-3. Baud Rate Select**

BR2	BR1	BR0	Baud Rate
0	0	0	100k
0	0	1	50k
0	1	0	25k
0	1	1	12.5k
1	0	0	6.25k
1	0	1	3.125k
1	1	0	1.56k
1	1	1	0.78k
NOTE: CPU bus clock is external clock ÷ 4 = 6MHz			

13.6.5 DDC Status Register (DSR)

Address: \$0019

	Bit 7	6	5	4	3	2	1	Bit 0
Read:	RXIF	TXIF	MATCH	SRW	RXAK	SCLIF	TXBE	RXBF
Write:	0	0				0		
Reset:	0	0	0	0	1	0	1	0

= Unimplemented

Figure 13-5. DDC Status Register (DSR)

**RXIF — DDC Receive Interrupt Flag**

This flag is set after the data receive register (DDRR) is loaded with a new received data. Once the DDRR is loaded with received data, no more received data can be loaded to the DDRR register until the CPU reads the data from the DDRR to clear RXBF flag. RXIF generates an interrupt request to CPU if the DIEN bit in DCR is also set. This bit is cleared by writing "0" to it or by reset; or when the DEN = 0.

- 1 = New data in data receive register (DDRR)
- 0 = No data received

**TXIF — DDC Transmit Interrupt Flag**

This flag is set when data in the data transmit register (DDTR) is downloaded to the output circuit, and that new data can be written to the DDTR. TXIF generates an interrupt request to CPU if the DIEN bit in DCR is also set. This bit is cleared by writing "0" to it or when the DEN = 0.

- 1 = Data transfer completed
- 0 = Data transfer in progress

**MATCH — DDC Address Match**

This flag is set when the received data in the data receive register (DDRR) is an calling address which matches with the address or its extended addresses (EXTAD=1) specified in the DADR register.

- 1 = Received address matches DADR
- 0 = Received address does not match

**SRW — DDC Slave Read/Write**

This bit indicates the data direction when the module is in slave mode. It is updated after the calling address is received from a master device. SRW = 1 when the calling master is reading data from the module (slave transmit mode). SRW = 0 when the master is writing data to the module (receive mode).

- 1 = Slave mode transmit
- 0 = Slave mode receive

**RXAK — DDC Receive Acknowledge**

When this bit is cleared, it indicates an acknowledge signal has been received after the completion of 8 data bits transmission on the bus. When RXAK is set, it indicates no acknowledge signal has been detected at the 9th clock; the module will release the SDA line for the master to generate "stop" or "repeated start" condition. Reset sets this bit.

- 1 = No acknowledge signal received at 9th clock bit
- 0 = Acknowledge signal received at 9th clock bit

**SCLIF — SCL Interrupt Flag**

This flag is set when a falling edge is detected on the SCL line, only if DDC1EN bit is set. SCLIF generates an interrupt request to CPU if the SCLIFEN bit in DCR is also set. SCLIF is cleared by writing "0" to it or when the DDC1EN = 0, or DEN = 0. Reset clears this bit.

- 1 = Falling edge detected on SCL line
- 0 = No falling edge detected on SCL line

**TXBE — DDC Transmit Buffer Empty**

This flag indicates the status of the data transmit register (DDTR). When the CPU writes the data to the DDTR, the TXBE flag will be cleared. TXBE is set when DDTR is emptied by a transfer of its data to the output circuit. Reset sets this bit.

- 1 = Data transmit register empty
- 0 = Data transmit register full

RXBF — DDC Receive Buffer Full

This flag indicates the status of the data receive register (DDRR). When the CPU reads the data from the DDRR, the RXBF flag will be cleared. RXBF is set when DDRR is full by a transfer of data from the input circuit to the DDRR. Reset clears this bit.

- 1 = Data receive register full
- 0 = Data receive register empty

13.6.6 DDC Data Transmit Register (DDTR)

Address: \$001A

	Bit 7	6	5	4	3	2	1	Bit 0
Read:	DTD7	DTD6	DTD5	DTD4	DTD3	DTD2	DTD1	DTD0
Write:								
Reset:	1	1	1	1	1	1	1	1

Figure 13-6. DDC Data Transmit Register (DDTR)

When the DDC module is enabled, DEN = 1, data written into this register depends on whether module is in master or slave mode.

In slave mode, the data in DDTR will be transferred to the output circuit when:

- the module detects a matched calling address (MATCH = 1), with the calling master requesting data (SRW = 1); or
- the previous data in the output circuit has been transmitted and the receiving master returns an acknowledge bit, indicated by a received acknowledge bit (RXAK = 0).

If the calling master does not return an acknowledge bit (RXAK = 1), the module will release the SDA line for master to generate a "stop" or "repeated start" condition. The data in the DDTR will not be transferred to the output circuit until the next calling from a master. The transmit buffer empty flag remains cleared (TXBE = 0).

In master mode, the data in DDTR will be transferred to the output circuit when:

- the module receives an acknowledge bit (RXAK = 0), after setting master transmit mode (MRW = 0), and the calling address has been transmitted; or
- the previous data in the output circuit has been transmitted and the receiving slave returns an acknowledge bit, indicated by a received acknowledge bit (RXAK = 0).

If the slave does not return an acknowledge bit (RXAK = 1), the master will generate a "stop" or "repeated start" condition. The data in the DDTR will not be transferred to the output circuit. The transmit buffer empty flag remains cleared (TXBE = 0).

The sequence of events for slave transmit and master transmit are illustrated in **Figure 13-8**.

### 13.6.7 DDC Data Receive Register (DDRR)

Address: \$001B

	Bit 7	6	5	4	3	2	1	Bit 0
Read:	DRD7	DRD6	DRD5	DRD4	DRD3	DRD2	DRD1	DRD0
Write:								
Reset:	0	0	0	0	0	0	0	0

 = Unimplemented

**Figure 13-7. DDC Data Receive Register (DDRR)**

When the DDC module is enabled, DEN = 1, data in this read-only register depends on whether module is in master or slave mode.

In slave mode, the data in DDRR is:

- the calling address from the master when the address match flag is set (MATCH = 1); or
- the last data received when MATCH = 0.

In master mode, the data in the DDRR is:

- the last data received.

When the DDDR is read by the CPU, the receive buffer full flag is cleared (RXBF = 0), and the next received data is loaded to the DDDR. Each time when new data is loaded to the DDDR, the RXIF interrupt flag is set, indicating that new data is available in DDDR.

The sequence of events for slave receive and master receive are illustrated in [Figure 13-8](#).

## 13.7 Programming Considerations

When the DDC module detects an arbitration loss in master mode, it will release both SDA and SCL lines immediately. But if there are no further STOP conditions detected, the module will hang up. Therefore, it is recommended to have time-out software to recover from such ill condition. The software can start the time-out counter by looking at the BB (Bus Busy) flag in the DMCR and reset the counter on the completion of one byte transmission. If a time-out occur, software can clear the DEN bit (disable DDC module) to release the bus, and hence clearing the BB flag. This is the only way to clear the BB flag by software if the module hangs up due to a no STOP condition received. The DDC can resume operation again by setting the DEN bit.

(a) Master Transmit Mode

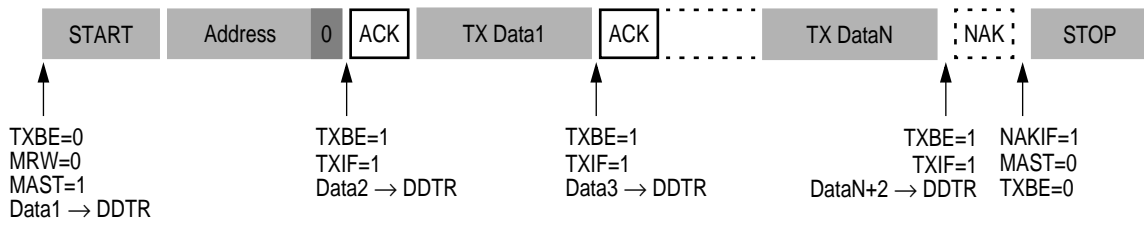

(b) Master Receive Mode

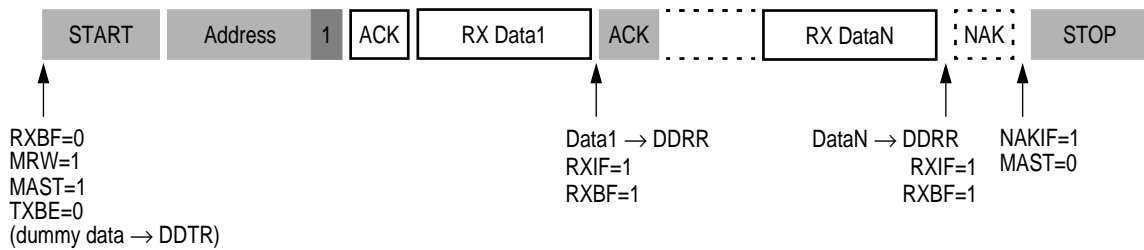

(c) Slave Transmit Mode

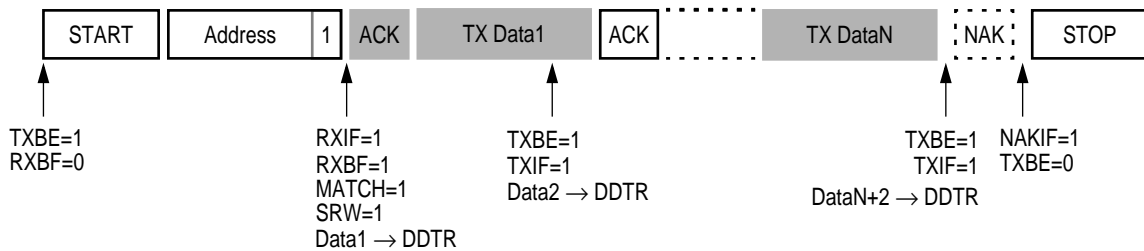

(d) Slave Receive Mode

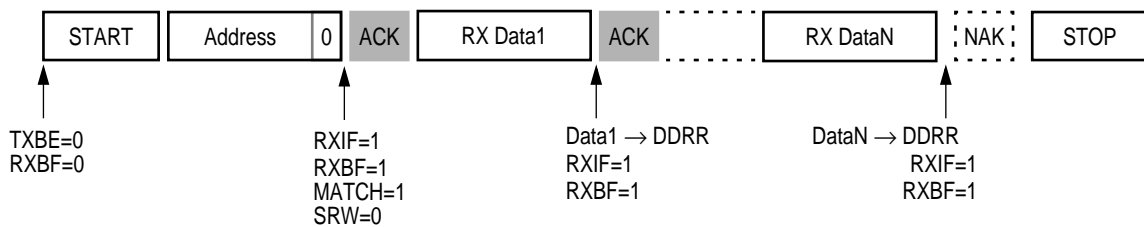

KEY: shaded data packets indicate a transmit by the MCU's DDC module

Figure 13-8. Data Transfer Sequences for Master/Slave Transmit/Receive Modes





## Section 14. Sync Processor

### 14.1 Contents

14.2	Introduction	170
14.3	Features	170
14.4	I/O Pins	171
14.5	Functional Blocks	173
14.5.1	Polarity Detection	174
14.5.1.1	Hsync Polarity Detection	174
14.5.1.2	Vsync Polarity Detection	174
14.5.1.3	Composite Sync Polarity Detection	174
14.5.2	Sync Signal Counters	175
14.5.3	Polarity Controlled HSYNCO and VSYNCO Outputs	175
14.5.4	Clamp Pulse Output	176
14.5.5	Low Vertical Frequency Detect	177
14.6	Registers	177
14.6.1	Sync Processor Control & Status Register (SPCSR)	177
14.6.2	Sync Processor Input/Output Control Register (SPIOCR)	179
14.6.3	Vertical Frequency Registers (VFRs)	181
14.6.4	Hsync Frequency Registers (HFRs)	183
14.6.5	Sync Processor Control Register 1 (SPCR1)	185
14.6.6	H&V Sync Output Control Register (HVOCR)	186
14.7	System Operation	187

## 14.2 Introduction

The Sync Processor is designed to detect and process sync signals inside a digital monitor system — from separated Hsync and Vsync inputs, or from composite sync inputs such as Sync-On-Green (SOG). After detection and the necessary polarity correction and/or sync separation, the corrected sync signals are sent out. The MCU can also send commands to other monitor circuitry, such as for the geometry correction and OSD, using the DDC12AB and/or the IIC communication channels.

The block diagram of the Sync Processor is shown in [Figure 14-1](#).

**NOTE:** *All quoted timings in this section assume an internal bus frequency of 6MHz.*

## 14.3 Features

Features of the Sync Processor include the following:

- Polarity detector
- Horizontal frequency counter
- Vertical frequency counter
- Low vertical frequency indicator (40.7Hz)
- Polarity controlled HSYNCO and VSYNCO outputs:
  - From separate Hsync and Vsync
  - From composite sync on HSYNC or SOG input pin
  - From internal selectable free running Hsync and Vsync pulses
- CLAMP pulse output to the external pre-amp chip
- Internal schmitt trigger on HSYNCO, VSYNCO, and SOG input pins to improve noise immunity

## 14.4 I/O Pins

The Sync Processor uses six I/O pins, with four pins shared with standard port I/O pins. The full name of the Sync Processor I/O pins are listed in [Table 14-1](#). The generic pin name appear in the text that follows.

**Table 14-1. Pin Name Conventions**

Sync Processor Generic Pin Names:	Full MCU Pin Names:	Pin Selected for Sync Processor Function By:
HSYNC	HSYNC	—
VSYNC	VSYNC	—
SOG	PTE0/SOG/TCH0	SOGE bit in CONFIG1 (\$001D)
HSYNCO	PTE1/HSYNCO	HSYNCOE bit in CONFIG 1 (\$001D)
VSYNCO	PTE2/VSYNCO	VSYNCOE bit in CONFIG 1 (\$001D)
CLAMP	PTD4/CLAMP	CLAMPE bit in PDCR (\$0049)

Table 14-2. Sync Processor I/O Register Summary

Addr.	Register Name		Bit 7	6	5	4	3	2	1	Bit 0
\$0040	Sync Processor Control and Status Register (SPCSR)	Read:	VSIE	VEDGE	VSIF	COMP	VINVO	HINVO	VPOL	HPOL
		Write:			0					
		Reset:	0	0	0	0	0	0	0	0
\$0041	Vertical Frequency High Register (VFHR)	Read:	VOF	0	0	VF12	VF11	VF10	VF9	VF8
		Write:		CPW1	CPW0					
		Reset:	0	0	0	0	0	0	0	0
\$0042	Vertical Frequency Low Register (VFLR)	Read:	VF7	VF6	VF5	VF4	VF3	VF2	VF1	VF0
		Write:								
		Reset:	0	0	0	0	0	0	0	0
\$0043	Hsync Frequency High Register (HFHR)	Read:	HFH7	HFH6	HFH5	HFH4	HFH3	HFH2	HFH1	HFH0
		Write:								
		Reset:	0	0	0	0	0	0	0	0
\$0044	Hsync Frequency Low Register (HFLR)	Read:	HOVER	0	0	HFL4	HFL3	HFL2	HFL1	HFL0
		Write:								
		Reset:	0	0	0	0	0	0	0	0
\$0045	Sync Processor I/O Control Register (SPIOCR)	Read:	VSYNCS	HSYNCS	COINV	R	SOGSEL	CLAMPOE	BPOR	SOUT
		Write:								
		Reset:	0	0	0	0	0	0	0	0
\$0046	Sync Processor Control Register 1 (SPCR1)	Read:	LVSIE	LVSIF	HPS1	HPS0	R	R	ATPOL	FSHF
		Write:		0						
		Reset:	0	0	0	0	0	0	0	0
\$0047	H&V Sync Output Control Register (HVOCR)	Read:	R	0	0	0	0	HVOCR2	HVOCR1	HVOCR0
		Write:								
		Reset:	0	0	0	0	0	0	0	0

= Unimplemented
  = Reserved

14.5 Functional Blocks

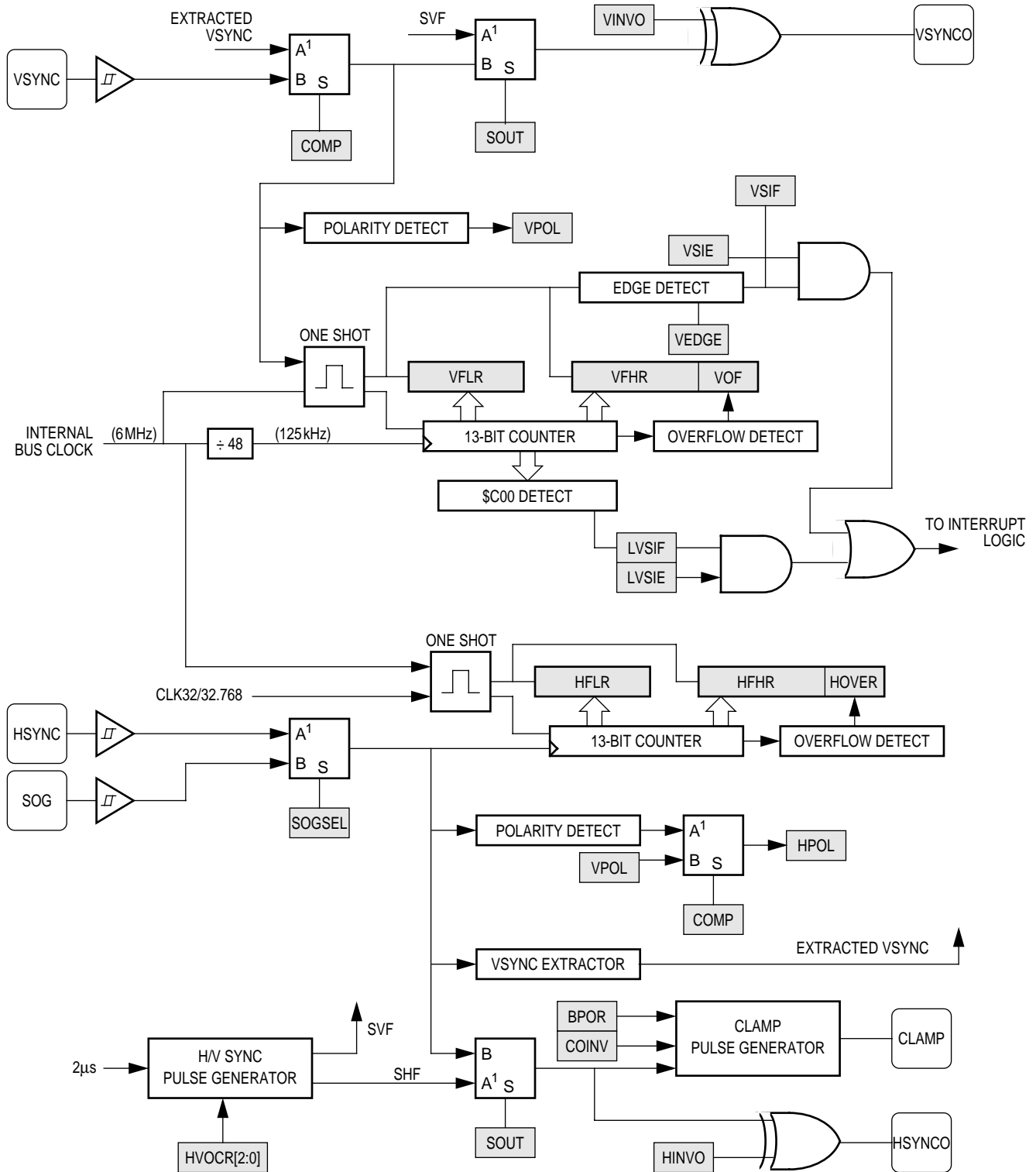

Figure 14-1. Sync Processor Block Diagram

## 14.5.1 Polarity Detection

### 14.5.1.1 Hsync Polarity Detection

The Hsync polarity detection circuit measures the length of high and low period of the HSYNC input. If the length of high is longer than  $L$  and the length of low is shorter than  $S$ , the HPOL bit will be "0", indicating a negative polarity HSYNC input. If the length of low is longer than  $L$  and the length of high is shorter than  $S$ , the HPOL bit will be "1", indicating a positive polarity HSYNC input. The table below shows three possible cases for HSYNC polarity detection — the conditions are selected by the HPS[1:0] bits in the Sync Processor Control Register 1 (SPCR1).

Polarity Detection Pulse Width		SPCR1 (\$0046)	
Long is greater than ( $L$ )	Short is less than ( $S$ )	HPS1	HPS0
7 $\mu$ s	6 $\mu$ s	0	0
3.5 $\mu$ s	3 $\mu$ s	1	X
14 $\mu$ s	12 $\mu$ s	0	1

### 14.5.1.2 Vsync Polarity Detection

The Vsync polarity detection circuit performs a similar function as for Hsync. If the length of high is longer than 4ms and the length of low is shorter than 2ms, the VPOL bit will be "0", indicating a negative polarity VSYNC input. If the length of low is longer than 4ms and the length of high is shorter than 2ms, the VPOL bit will be "1", indicating a positive polarity VSYNC input.

### 14.5.1.3 Composite Sync Polarity Detection

When a composite sync signal is the input (COMP = 1 for composite sync processing), the HPOL bit = VPOL bit, and the polarity is detected using the VSYNC polarity detection criteria described in section [14.5.1.2](#).

### 14.5.2 Sync Signal Counters

There are two counters: a 13-bit horizontal frequency counter to count the number of horizontal sync pulses within a 32ms or 8ms period; and a 13-bit vertical frequency counter to count the number of system clock cycles between two vertical sync pulses. These two data can be read by the CPU to check the signal frequencies and to determine the video mode.

The 13-bit vertical frequency register encompasses vertical frequency range from approximately 15Hz to 128kHz. Due to the asynchronous timing between the incoming VSYNC signal and internal system clock, there will be  $\pm 1$  count error on reading the **Vertical Frequency Registers (VFRs)** for the same vertical frequency.

The horizontal counter counts the pulses on HSYNC pin input, and is uploaded to the **Hsync Frequency Registers (HFRs)** every 32.768ms or 8.192ms.

### 14.5.3 Polarity Controlled HSYNCO and VSYNCO Outputs

The processed sync signals are output on HSYNCO and VSYNCO when the corresponding bits in Configuration Register 0 (\$001D) are set. The signal to these output pins depend on SOUT and COMP bits (see **Table 14-3**), with polarity controlled by ATPOL, HINVO, and VINVO bits as shown in **Table 14-4**.

**Table 14-3. Sync Output Control**

SOUT	COMP	Sync Outputs: VSYNCO and HSYNCO
1	X	Free-running pulse with negative polarity
0	0	Sync outputs follow sync inputs VSYNC and HSYNC respectively, with polarity correction shown in <b>Table 14-4</b> .
0	1	HSYNCO follows the composite sync input and VSYNCO is the extracted Vsync (3 to 14 $\mu$ s delay to composite input), with polarity correction shown in <b>Table 14-4</b> .

Table 14-4. Sync Output Polarity

ATPOL	SOUT	VINVO or HINVO	Sync Outputs: VSYNCO/HSYNCO
X	1	X	Free-running pulse with negative polarity
0	0	0	Same polarity as sync input
0	0	1	Inverted polarity of sync input
1	0	0	Negative polarity sync output
1	0	1	Positive polarity sync output

When the SOUT bit is set, the HSYNCO output is a free-running pulse with 2µs width. Both HSYNCO and VSYNCO outputs are negative polarity, with frequencies selected by the H & V Sync Output Control Register (HVOCR).

#### 14.5.4 Clamp Pulse Output

When the CLAMPOE bit in SPIOCR is set to "1", a clamp signal is output on the CLAMP pin. This clamp pulse is triggered either on the leading edge or the trailing edge of HSYNC, controlled by BPOR bit, with the polarity controlled by the COINV bit. See [Figure 14-2 . Clamp Pulse Output Timing](#).

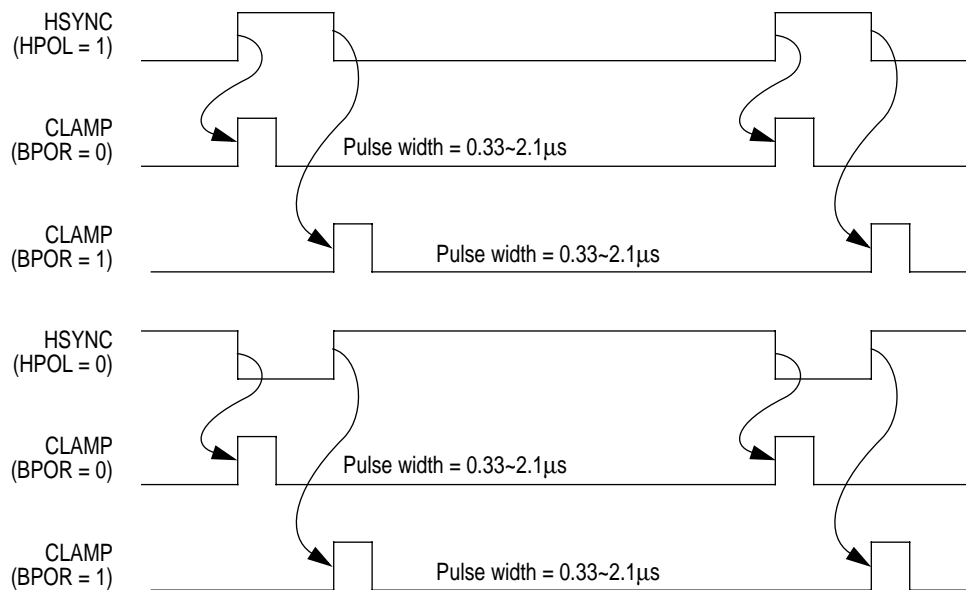

Figure 14-2. Clamp Pulse Output Timing



### 14.5.5 Low Vertical Frequency Detect

Logic monitors the value of the Vsync Frequency Register (VFR), and sets the low vertical frequency flag (LVSIF) when the value of VFR is higher than \$C00 (frequency below 40.7Hz). LVSIF bit can generate an interrupt request to the CPU when the LVSIE bit is set and I-bit in the Condition Code Register is "0". The LVSIF bit can help the system to detect video off mode fast.

## 14.6 Registers

Eight registers are associated with the Sync Processor, they outlined in the following sections.

### 14.6.1 Sync Processor Control & Status Register (SPCSR)

Address: \$0040

	Bit 7	6	5	4	3	2	1	Bit 0
Read:	VSIE	VEDGE	VSIF	COMP	VINVO	HINVO	VPOL	HPOL
Write:			0					
Reset:	0	0	0	0	0	0	0	0

= Unimplemented

**Figure 14-3. Sync Processor Control & Status Register (SPCSR)**

#### VSIE — VSync Interrupt Enable

When this bit is set, the VSIF flag is enabled to generate an interrupt request to the CPU. When VSIE is cleared, the VSIF flag is prevented from generating an interrupt request to the CPU. Reset clears this bit.

1 = VSIF bit set will generate interrupt request to CPU

0 = VSIF bit set does not generate interrupt request to CPU

## VEDGE — VSync Interrupt Edge Select

This bit specifies the triggering edge of Vsync interrupt. When it is "0", the rising edge of internal Vsync signal which is either from the VSYNC pin or extracted from the composite input signal will set VSIF flag. When it is "1", the falling edge of internal Vsync signal will set VSIF flag. Reset clears this bit.

1 = VSIF bit will be set by rising edge of Vsync

0 = VSIF bit will be set by falling edge of Vsync

## VSIF — VSync Interrupt Flag

This flag is only set by the specified edge of the internal Vsync signal, which is either from the VSYNC input pin or extracted from the composite sync input signal. The triggering edge is specified by the VEDGE bit. VSIF generates an interrupt request to the CPU if the VSIE bit is also set. This bit is cleared by writing a "0" to it or by a reset.

1 = A valid edge is detected on the Vsync

0 = No valid Vsync is detected

## COMP — Composite Sync Input Enable

This bit is set to enable the separator circuit which extracts the Vsync pulse from the composite sync input on HSYNC or SOG pin (select by SOGSEL bit). The extracted Vsync signal is used as it were from the VSYNC input. Reset clears this bit.

1 = Composite Sync Input Enabled

0 = Composite Sync Input Disabled

## VINVO — VSYNCO Signal Polarity

This bit, together with the ATPOL bit in SPCR1 controls the output polarity of the VSYNCO signal (see [Table 14-5](#)).

## HINVO — HSYNCO Signal Polarity

This bit, together with the ATPOL bit in SPCR1 controls the output polarity of the HSYNCO signal (see [Table 14-5](#)).

Table 14-5. ATPOL, VINVO, and HINVO setting

ATPOL	VINVO / HINVO	Sync Outputs: VSYNCO/HSYNCO
0	0	Same polarity as sync input
0	1	Inverted polarity of sync input
1	0	Negative polarity sync output
1	1	Positive polarity sync output

VPOL — Vsync Input Polarity

This bit indicates the polarity of the VSYNC input, or the extracted Vsync from a composite sync input (COMP=1). Reset clears this bit.

- 1 = Vsync is positive polarity
- 0 = Vsync is negative polarity

HPOL — Hsync Input Polarity

This bit indicates the polarity of the HSYNC input. This bit equals the VPOL bit when the COMP bit is set. Reset clears this bit.

- 1 = Hsync is positive polarity
- 0 = Hsync is negative polarity

14.6.2 Sync Processor Input/Output Control Register (SPIOCR)

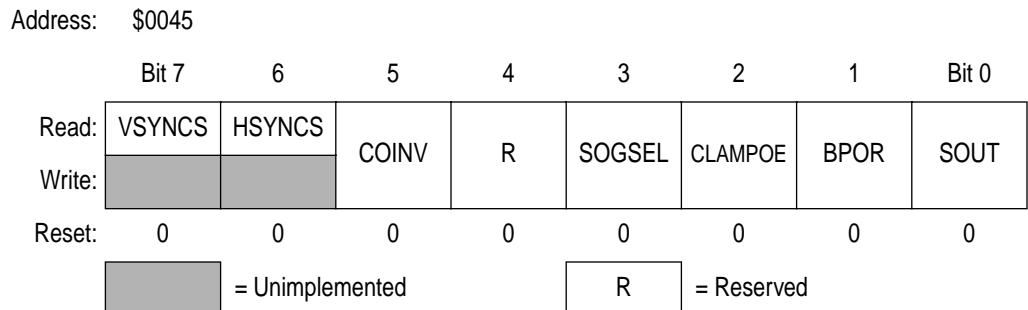

Figure 14-4. Sync Processor Input/Output Control Register (SPIOCR)

VSYNCS — VSYNC Input State

This read-only bit reflects the logical state of the VSYNC input.

HSYNCS — HSYNC Input State

This read-only bit reflects the logical state of the HSYNC input.

**COINV — Clamp Output Invert**

This bit is set to invert the clamp pulse output to negative. Reset clears this bit.

1 = clamp output is set for negative pulses

0 = clamp output is set for positive pulses

**SOGSEL — SOG Select**

This bit selects either the HSYNC pin or SOG pin as the composite sync signal input pin. Reset clears this bit.

1 = SOG pin is used as the composite sync input

0 = HSYNC pin is used as the composite sync input

**CLAMPOE — Clamp Output Enable**

This bit is set to enable the clamp pulse output circuitry. Reset clears this bit.

1 = Clamp pulse circuit enabled

0 = Clamp pulse circuit disabled

**BPOR — Back Porch**

This bit defines the triggering edge of the clamp pulse output relative to the HSYNC input. Reset clears this bit.

1 = Clamp pulse is generated on the trailing edge of HSYNC

0 = Clamp pulse is generated on the leading edge of HSYNC

**SOUT — Sync Output Enable**

This bit will select the output signals for the VSYNCO and HSYNCO pins. Reset clears this bit.

1 = VSYNCO and HSYNCO outputs are internally generated free-running sync pulses with frequencies determined by HVCOR[2:0] bits in HVCOR.

0 = VSYNCO and HSYNCO outputs are processed VSYNC and HSYNC inputs respectively

14.6.3 Vertical Frequency Registers (VFRs)

This register pair contains the 13-bit vertical frequency count value, an overflow bit, and the clamp pulse width selection bits.

Address: \$0041

	Bit 7	6	5	4	3	2	1	Bit 0
Read:	VOF	0	0	VF12	VF11	VF10	VF9	VF8
Write:		CPW1	CPW0					
Reset:	0	0	0	0	0	0	0	0

Figure 14-5. Vertical Frequency High Register

Address: \$0042

	Bit 7	6	5	4	3	2	1	Bit 0
Read:	VF7	VF6	VF5	VF4	VF3	VF2	VF1	VF0
Write:								
Reset:	0	0	0	0	0	0	0	0

 = Unimplemented

Figure 14-6. Vertical Frequency Low Register

VF[12:0] — Vertical Frame Frequency

This read-only 13-bit contains information of the vertical frame frequency. An internal 13-bit counter counts the number of 8μs periods between two Vsync pulses. The most significant 5 bits of the counted value is transferred to the high byte register, and the least significant 8 bits is transferred to an intermediate buffer. When the high byte register is read, the 8-bit counted value stored in the intermediate buffer will be uploaded to the low byte register. Therefore, user program must read the high byte register first, then low byte register in order to get the complete counted value of one vertical frame. If the counter overflows, the overflow flag, VOF, will be set, indicating the counter value stored in the VFRs is meaningless. The data corresponds to the period of one vertical frame. This register can be read to determine if the frame frequency is valid, and to determine the video mode.

The frame frequency is calculated by:

$$\text{Vertical Frame Frequency} = \frac{1}{\text{VFR} \pm 1 \times 48 \times t_{\text{CYC}}}$$

$$= \frac{1}{\text{VFR} \pm 1 \times 8\mu\text{s}}$$

for internal bus clock of 6 MHz

Table 14-6 shows examples for the Vertical Frequency Register, all VFR numbers are in hexadecimal.

Table 14-6. Sample Vertical Frame Frequencies

VFR	Max Freq.	Min Freq.	VFR	Max Freq.	Min Freq.
\$02A0	186.20 Hz	185.70 Hz	\$0780	65.10 Hz	65.00 Hz
\$03C0	130.34 Hz	130.07 Hz	\$0823	60.04 Hz	59.98 Hz
\$03C1	130.21 Hz	129.94 Hz	\$0824	60.01 Hz	59.95 Hz
\$03C2	130.07 Hz	129.80 Hz	\$0825	59.98 Hz	59.92 Hz
\$04E2	100.08 Hz	99.92 Hz	\$09C4	50.02 Hz	49.98 Hz
\$04E3	100.00 Hz	99.84 Hz	\$09C5	50.00 Hz	49.96 Hz
\$04E4	99.92 Hz	99.76 Hz	\$09C6	49.98 Hz	49.94 Hz
\$06F9	70.07 Hz	69.99 Hz	\$1FFD	15.266 Hz	15.262 Hz
\$06FA	70.03 Hz	69.95 Hz	\$1FFE	15.264 Hz	15.260 Hz
\$06FB	69.99 Hz	69.91 Hz	\$1FFF	15.262 Hz	15.258 Hz

VOF — Vertical Frequency Counter Overflow

This read-only bit is set when an overflow has occurred on the 13-bit vertical frequency counter. Reset clears this bit, and will be updated every vertical frame.

An overflow occurs when the period of Vsync frame exceeds 64.768ms (a vertical frame frequency lower than 15.258Hz).

1 = A vertical frequency counter overflow has occurred

0 = No vertical frequency counter overflow has occurred

CPW[1:0] — Clamp Pulse Width

The CPW1 and CPW0 bits are used to select the output clamp pulse width. Reset clears these bits, selecting a default clamp pulse width between 0.33μs and 0.375μs. These bits always read as Zeros.

Table 14-7. Clamp Pulse Width

CPW1	CPW0	Clamp Pulse Width
0	0	0.33μs to 0.375μs
0	1	0.5μs to 0.542μs
1	0	0.75μs to 0.792μs
1	1	2μs to 2.042μs

14.6.4 Hsync Frequency Registers (HFRs)

This register pair contains the 13-bit Hsync frequency count value and an overflow bit.

Address: \$0043

	Bit 7	6	5	4	3	2	1	Bit 0
Read:	HFH7	HFH6	HFH5	HFH4	HFH3	HFH2	HFH1	HFH0
Write:								
Reset:	0	0	0	0	0	0	0	0

Figure 14-7. Hsync Frequency High Register

Address: \$0044

	Bit 7	6	5	4	3	2	1	Bit 0
Read:	HOVER	0	0	HFL4	HFL3	HFL2	HFL1	HFL0
Write:								
Reset:	0	0	0	0	0	0	0	0

 = Unimplemented

Figure 14-8. Hsync Frequency Low Register

## HFH[7:0], HFL[4:0] — Horizontal Line Frequency

This read-only 13-bit contains the number of horizontal lines in a 32ms window. An internal 13-bit counter counts the Hsync pulses within a 32ms window in every 32.768ms period. If the FSHF bit in SPCR1 is set, only the most 11-bits (HFH[7:0] & HFL[4:2]) will be updated by the counter. Thus, providing a Hsync pulse count in a 8ms window in every 8.192ms.

The most significant 8 bits of counted value is transferred to the high byte register, and the least significant 5 bits is transferred to an intermediate buffer. When the high byte register is read, the 5-bit counted value stored in the intermediate buffer will be uploaded to the low byte register. Therefore, user the program must read the high byte register first then low byte register in order to get the complete counted value of Hsync pulses. If the counter overflows, the overflow flag, HOVER, will be set, indicating the number of Hsync pulses in 32ms are more than 8191 ( $2^{13}-1$ ), i.e. a Hsync frequency greater than 256kHz.

For the 32ms window, the HFHR and HFLR are such that the frequency step unit in the 5-bit of HFLR is 0.03125kHz, and the step unit in the 8-bit HFHR is 1kHz. Therefore, the Hsync frequency can be easily calculated by:

$$\text{Hsync Frequency} = [\text{HFH} + (\text{HFL} \times 0.03125)]\text{kHz}$$

where: *HFH* is the value of HFH[7:0]

*HFL* is the value of HFL[4:0]

## HOVER — Hsync Frequency Counter Overflow

This read-only bit is set when an overflow has occurred on the 13-bit Hsync frequency counter. Reset clears this bit, and will be updated every count period.

An overflow occurs when the number Hsync pulses exceed 8191, a Hsync frequency greater than 256kHz.

1 = A Hsync frequency counter overflow has occurred

0 = No Hsync frequency counter overflow has occurred



14.6.5 Sync Processor Control Register 1 (SPCR1)

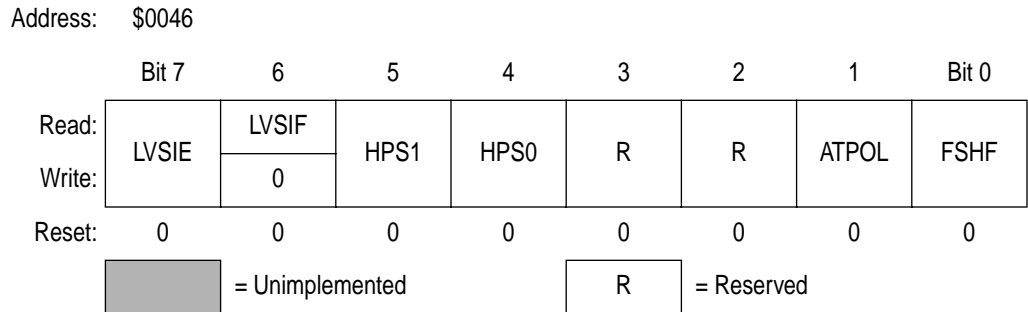

Figure 14-9. Sync Processor Control Register 1 (SPCR1)

LVSIE — Low VSync Interrupt Enable

When this bit is set, the LVSIF flag is enabled to generate an interrupt request to the CPU. When LVSIE is cleared, the LVSIF flag is prevented from generating an interrupt request to the CPU. Reset clears this bit.

- 1 = Low Vsync interrupt enabled
- 0 = Low Vsync interrupt disabled

LVSIF — Low VSync Interrupt Flag

This read-only bit is set when the value of VFR is higher than \$C00 (vertical frame frequency below 40.7Hz). LVSIF generates an interrupt request to the CPU if the LVSIE is also set. This bit is cleared by writing a "0" to it or reset.

- 1 = Vertical frequency is below 40.7Hz
- 0 = Vertical frequency is higher than 40.7Hz

HPS[1:0] — HSYNC input Detection Pulse Width

These two bits control the detection pulse width of HSYNC input. Reset clears these two bits, setting a default middle frequency of HSYNC input.

Table 14-8. HSYNC Polarity Detection Pulse Width

HPS1	HPS0	Polarity Detection Pulse Width
0	0	Long > 7µs and Short < 6µs
1	X	Long > 3.5µs and Short < 3µs
0	1	Long > 14µs and Short < 12µs

ATPOL — Auto Polarity

This bit, together with the VINVO or HINVO bits in SPCSR controls the output polarity of the VSYNCO or HSYNCO signals respectively. Reset clears this bit (see [Table 14-9](#)).

**Table 14-9. ATPOL, VINVO, and HINVO setting**

ATPOL	VINVO / HINVO	Sync Outputs: VSYNCO/HSYNCO
0	0	Same polarity as sync input
0	1	Inverted polarity of sync input
1	0	Negative polarity sync output
1	1	Positive polarity sync output

FSHF — Fast Horizontal Frequency Count

This bit is set to shorten the measurement cycle of the horizontal frequency. If it is set, only HFH[7:0] and HFL[4:2] will be updated by the Hsync counter, providing a count in a 8ms window in every 8.192ms, with HFL[1:0] reading as zeros. Therefore, user can determine the horizontal frequency change within 8.192ms to protect critical circuitry. Reset clears this bit.

- 1 = Number of Hsync pulses is counted in an 8ms window
- 0 = Number of Hsync pulses is counted in a 32ms window

14.6.6 H&V Sync Output Control Register (HVOCR)

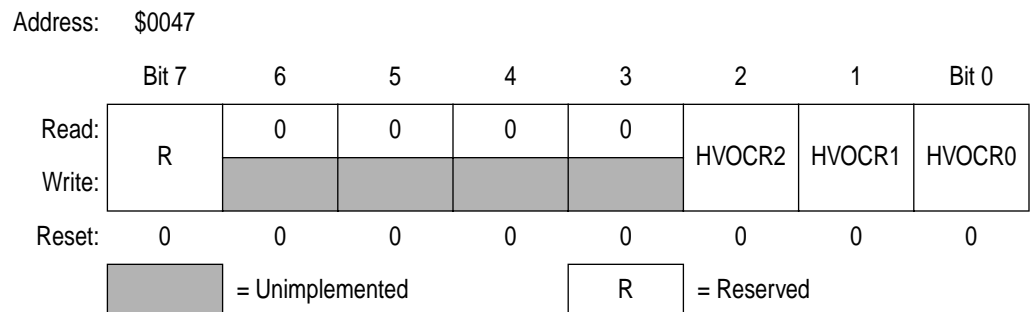

**Figure 14-10. H&V Sync Output Control Register (HVOCR)**

**HVOCR[2:0] — H&V Output Select Bits**

These three bits select the frequencies of the internal generated free-running sync pulses for output to HSYNCO and VSYNCO pins, when the SOUT bit is set in the SPIOCR. Reset clears these bits, setting a default horizontal frequency of 31.25kHz and a vertical frequency of 60Hz, a video mode of 640×480.

**Table 14-10. Free-Running HSYNC and VSYNC Options**

HVOCR	HSYNCO		VSYNCO		Video Mode
	Pulse width	Frequency	Pulse width	Frequency	
000	Negative 2μs	31.25kHz	Negative 192μs	59.98 Hz	640 × 480
001	Negative 2μs	43.48kHz	Negative 138μs	84.92 Hz	640 × 480
010	Negative 2μs	48.78kHz	Negative 123μs	60.00 Hz	1024 × 768
011	Negative 2μs	54.05kHz	Negative 111μs	84.98 Hz	800 × 600
100	Negative 2μs	60.61 kHz	Negative 99μs	75.01 Hz	1024 × 768
101	Negative 2μs	80.00kHz	Negative 75μs	74.98 Hz	1280 × 1024
110	Negative 2μs	90.91 kHz	Negative 66μs	84.96 Hz	1280 × 1024
111	Negative 2μs	105.26 kHz	Negative 57μs	85.02 Hz	1600 × 1200

**14.7 System Operation**

This Sync Processor is designed to assist in determining the video mode of incoming HSYNC and VSYNC of various frequencies and polarities, and DPMS modes. In the DPMS standard, a no sync pulses definition can be detected when the value of the Hsync Frequency Register (the number of Hsync pulses) is less than one or when the VOF bit is set. Since the Hsync Frequency Register is updated repeatedly in every 32.768ms, and a valid Vsync must have a frequency greater than 40.7Hz, a valid Vsync pulse will arrive within the 32.768ms window. Therefore, the user should read the Hsync Frequency Register every 32.768ms to determine the presence of Hsync and/or Vsync pulses.



## Section 15. Input/Output (I/O) Ports

### 15.1 Contents

15.2	Introduction	190
15.3	Port A	193
15.3.1	Port A Data Register	193
15.3.2	Data Direction Register A	194
15.3.3	Port A Options	195
15.4	Port B	196
15.4.1	Port B Data Register	196
15.4.2	Data Direction Register B	197
15.4.3	Port B Options	198
15.5	Port C	199
15.5.1	Port C Data Register	199
15.5.2	Data Direction Register C	200
15.5.3	Port C Options	201
15.6	Port D	202
15.6.1	Port D Data Register	202
15.6.2	Data Direction Register D	203
15.6.3	Port D Options	205
15.7	Port E	206
15.7.1	Port E Data Register	206
15.7.2	Data Direction Register E	207
15.7.3	Port E Options	209

Input/Output (I/O) Ports

15.2 Introduction

Thirty-two (32) bidirectional input-output (I/O) pins form four parallel ports. All I/O pins are programmable as inputs or outputs.

**NOTE:** Connect any unused I/O pins to an appropriate logic level, either  $V_{DD}$  or  $V_{SS}$ . Although the I/O ports do not require termination for proper operation, termination reduces excess current consumption and the possibility of electrostatic damage.

Table 15-1. I/O Port Register Summary

Addr.	Register Name	Bit 7	6	5	4	3	2	1	Bit 0	
\$0000	Port A Data Register (PTA)	Read:	PTA7	PTA6	PTA5	PTA4	PTA3	PTA2	PTA1	PTA0
		Write:								
		Reset:	Unaffected by reset							
\$0001	Port B Data Register (PTB)	Read:	PTB7	PTB6	PTB5	PTB4	PTB3	PTB2	PTB1	PTB0
		Write:								
		Reset:	Unaffected by reset							
\$0002	Port C Data Register (PTC)	Read:	0	0	PTC5	PTC4	PTC3	PTC2	PTC1	PTC0
		Write:								
		Reset:	Unaffected by reset							
\$0003	Port D Data Register (PTD)	Read:	0	PTD6	PTD5	PTD4	PTD3	PTD2	PTD1	PTD0
		Write:								
		Reset:	Unaffected by reset							
\$0004	Data Direction Register A (DDRA)	Read:	DDRA7	DDRA6	DDRA5	DDRA4	DDRA3	DDRA2	DDRA1	DDRA0
		Write:								
		Reset:	0	0	0	0	0	0	0	0
\$0005	Data Direction Register B (DDRB)	Read:	DDRB7	DDRB6	DDRB5	DDRB4	DDRB3	DDRB2	DDRB1	DDRB0
		Write:								
		Reset:	0	0	0	0	0	0	0	0

 = Unimplemented

Table 15-1. I/O Port Register Summary (Continued)

Addr.	Register Name	Bit 7	6	5	4	3	2	1	Bit 0	
\$0006	Data Direction Register C (DDRC)	Read:	0	0	DDRC5	DDRC4	DDRC3	DDRC2	DDRC1	DDRC0
		Write:								
		Reset:	0	0	0	0	0	0	0	0
\$0007	Data Direction Register D (DDRD)	Read:	0	DDRD6	DDRD5	DDRD4	DDRD3	DDRD2	DDRD1	DDRD0
		Write:								
		Reset:	0	0	0	0	0	0	0	0
\$0008	Port E Data Register (PTE)	Read:	0	0	0	0	0	PTE2	PTE1	PTE0
		Write:								
		Reset:	Unaffected by reset							
\$0009	Data Direction Register E (DDRE)	Read:	0	0	0	0	0	DDRE2	DDRE1	DDRE0
		Write:								
		Reset:	0	0	0	0	0	0	0	0
\$001D	Configuration Register 0 (CONFIG0)	Read:	HSYNCOE	VSYNCOE	SOGE	0	0	0	0	0
		Write:								
		Reset:	0	0	0	0	0	0	0	0
\$0028	PWM Control Register 1 (PWMCR1)	Read:	PWM7E	PWM6E	PWM5E	PWM4E	PWM3E	PWM2E	PWM1E	PWM0E
		Write:								
		Reset:	0	0	0	0	0	0	0	0
\$0049	Port D Configuration Register (PDCR)	Read:	0	0	0	CLAMPE	DDCSCLE	DDCDATE	0	0
		Write:								
		Reset:	0	0	0	0	0	0	0	0
\$0059	PWM Control Register 2 (PWMCR2)	Read:	PWM15E	PWM14E	PWM13E	PWM12E	PWM11E	PWM10E	PWM9E	PWM8E
		Write:								
		Reset:	0	0	0	0	0	0	0	0

= Unimplemented

Table 15-2. Port Control Register Bits Summary

Port	Bit	DDR	Module Control			Pin
			Module	Register	Control Bit	
A	0	DDRA0	PWM	PWMCR2 \$0059	PWM8E	PTA0/PWM8
	1	DDRA1			PWM9E	PTA1/PWM9
	2	DDRA2			PWM10E	PTA2/PWM10
	3	DDRA3			PWM11E	PTA3/PWM11
	4	DDRA4			PWM12E	PTA4/PWM12
	5	DDRA5			PWM13E	PTA5/PWM13
	6	DDRA6			PWM14E	PTA6/PWM14
	7	DDRA7			PWM15E	PTA7/PWM15
B	0	DDRB0	PWM	PWMCR1 \$0028	PWM0E	PTB0/PWM0
	1	DDRB1			PWM1E	PTB1/PWM1
	2	DDRB2			PWM2E	PTB2/PWM2
	3	DDRB3			PWM3E	PTB3/PWM3
	4	DDRB4			PWM4E	PTB4/PWM4
	5	DDRB5			PWM5E	PTB5/PWM5
	6	DDRB6			PWM6E	PTB6/PWM6
	7	DDRB7			PWM7E	PTB7/PWM7
C	0	DDRC0	ADC	ADSCR \$005D	ADCH[4:0]	PTC0/ADC0
	1	DDRC1				PTC1/ADC1
	2	DDRC2				PTC2/ADC2
	3	DDRC3				PTC3/ADC3/
	4	DDRC4				PTC4/ADC4
	5	DDRC5				PTC5/ADC5
D	0	DDRD0	—	—	—	PTD0
	1	DDRD1	—	—	—	PTD1
	2	DDRD2	DDC12AB	PDCR \$0049	DDCDATE	PTD2/DDCSDA
	3	DDRD3			DDCSCLE	PTD3/DDCSCL
	4	DDRD4	SYNC		CLAMPE	PTD4/CLAMP
	5	DDRD5	—	—	—	PTD5
	6	DDRD6	—	—	—	PTD6
E	0	DDRE0	SYNC/TIM	CONFIG0 \$001D	SOGE	PTE0/SOG/TCH0
	1	DDRE1	SYNC		HSYNCOE	PTE1/HSYNCO
	2	DDRE2			VSYNCOE	PTE2/VSYNCO



## 15.3 Port A

Port A is an 8-bit special-function port that shares all eight of its pins with the pulse width modulator (PWM).

### 15.3.1 Port A Data Register

The port A data register (PTA) contains a data latch for each of the eight port A pins.

Address:	\$0000							
	Bit 7	6	5	4	3	2	1	Bit 0
Read:	PTA7	PTA6	PTA5	PTA4	PTA3	PTA2	PTA1	PTA0
Write:	PTA7	PTA6	PTA5	PTA4	PTA3	PTA2	PTA1	PTA0
Reset:	Unaffected by reset							
Alternate Function:	PWM15	PWM14	PWM13	PWM12	PWM11	PWM10	PWM9	PWM8

**Figure 15-1. Port A Data Register (PTA)**

#### PTA7–PTA0 — Port A Data Bits

These read/write bits are software programmable. Data direction of each port A pin is under the control of the corresponding bit in data direction register A. Reset has no effect on port A data.

#### PWM15–PWM8 — PWM Outputs 15–8

The PWM output enable bits PWM15E–PWM8E, in PWM control register 2 (PWMCR2) enable port A pins as PWM output pins. (See [15.3.3 Port A Options](#).)

15.3.2 Data Direction Register A

Data direction register A (DDRA) determines whether each port A pin is an input or an output. Writing a logic 1 to a DDRA bit enables the output buffer for the corresponding port A pin; a logic 0 disables the output buffer.

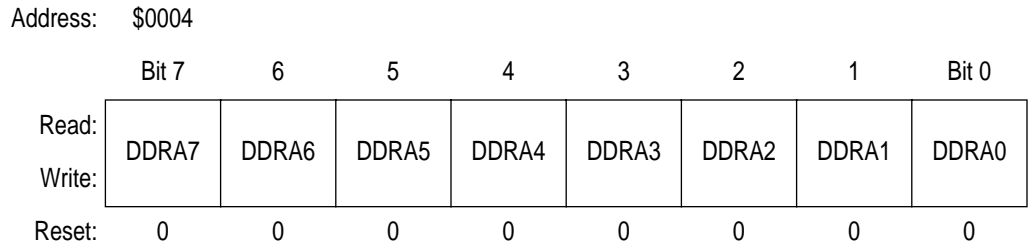

Figure 15-2. Data Direction Register A (DDRA)

DDRA7–DDRA0 — Data Direction Register A Bits

These read/write bits control port A data direction. Reset clears DDRA7–DDRA0, configuring all port A pins as inputs.

- 1 = Corresponding port A pin configured as output
- 0 = Corresponding port A pin configured as input

**NOTE:** Avoid glitches on port A pins by writing to the port A data register before changing data direction register A bits from 0 to 1.

Figure 15-3 shows the port A I/O logic.

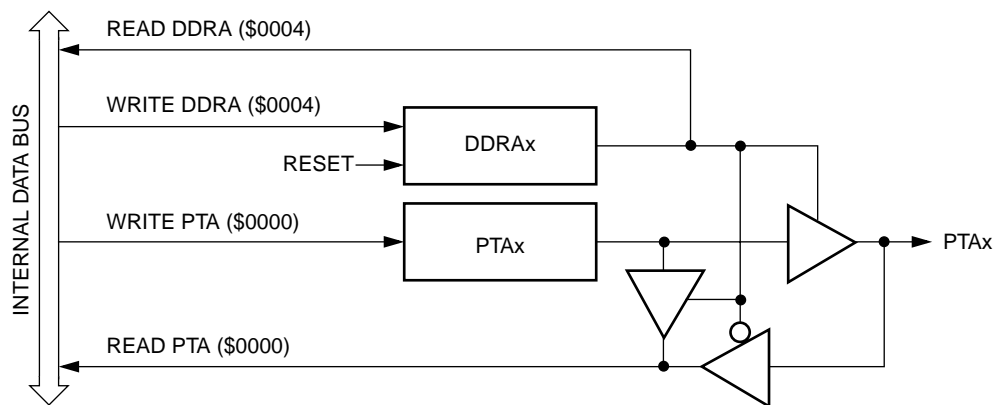

Figure 15-3. Port A I/O Circuit

When bit DDRAx is a logic 1, reading address \$0000 reads the PTAx data latch. When bit DDRAx is a logic 0, reading address \$0000 reads the voltage level on the pin. The data latch can always be written, regardless of the state of its data direction bit. [Table 15-3](#) summarizes the operation of the port A pins.

**Table 15-3. Port A Pin Functions**

PTAPUE Bit	DDRA Bit	PTA Bit	I/O Pin Mode	Accesses to DDRA	Accesses to PTA	
				Read/Write	Read	Write
0	0	X <sup>(1)</sup>	Input, Hi-Z <sup>(2)</sup>	DDRA7–DDRA0	Pin	PTA7–PTA0 <sup>(3)</sup>
X	1	X	Output	DDRA7–DDRA0	PTA7–PTA0	PTA7–PTA0

NOTES:

1. X = Don't care
2. Hi-Z = High impedance
3. Writing affects data register, but does not affect input.

15.3.3 Port A Options

The PWM control register 2 (PWMCR2) selects the port A pins for PWM function or as standard I/O function. See [11.4.2 PWM Control Registers 1 and 2 \(PWMCR1:PWMCR2\)](#).

Address: \$0059

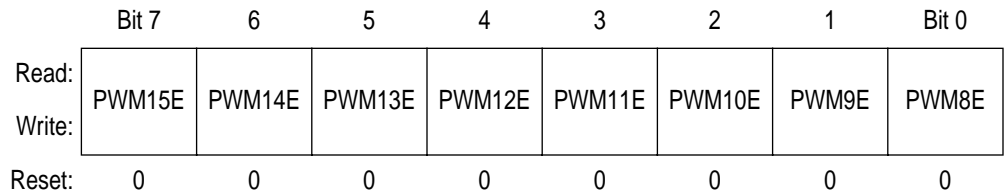

**Figure 15-4. PWM Control Register 1 (PWMCR1)**

PWM15E–PWM8E — PWM Output Enable 15–8

Setting a bit to "1" will configure the corresponding PTAx/PWMx pin for PWM output function. Reset clears these bits.

- 1 = PTAx/PWMx pin configured as PWMx output pin
- 0 = PTAx/PWMx pin configured as standard I/O pin

## 15.4 Port B

Port B is an 8-bit special-function port that shares all eight of its pins with the pulse width modulator (PWM).

### 15.4.1 Port B Data Register

The port B data register (PTB) contains a data latch for each of the eight port pins.

Address: \$0001

	Bit 7	6	5	4	3	2	1	Bit 0
Read:	PTB7	PTB6	PTB5	PTB4	PTB3	PTB2	PTB1	PTB0
Write:								
Reset:	Unaffected by reset							
Alternate Function:	PWM7	PWM6	PWM5	PWM4	PWM3	PWM2	PWM1	PWM0

**Figure 15-5. Port B Data Register (PTB)**

#### PTB7–PTB0 — Port B Data Bits

These read/write bits are software-programmable. Data direction of each port B pin is under the control of the corresponding bit in data direction register B. Reset has no effect on port B data.

#### PWM7–PWM0 — PWM Outputs 7–0

The PWM output enable bits PWM7E–PWM0E, in PWM control register 1 (PWMCR1) enable port B pins as PWM output pins. (See [15.4.3 Port B Options](#).)

15.4.2 Data Direction Register B

Data direction register B (DDRB) determines whether each port B pin is an input or an output. Writing a logic 1 to a DDRB bit enables the output buffer for the corresponding port B pin; a logic 0 disables the output buffer.

Address: \$0005

	Bit 7	6	5	4	3	2	1	Bit 0
Read:	DDRB7	DDRB6	DDRB5	DDRB4	DDRB3	DDRB2	DDRB1	DDRB0
Write:								
Reset:	0	0	0	0	0	0	0	0

Figure 15-6. Data Direction Register B (DDRB)

DDRB7–DDRB0 — Data Direction Register B Bits

These read/write bits control port B data direction. Reset clears [DDRB7–DDRB0], configuring all port B pins as inputs.

- 1 = Corresponding port B pin configured as output
- 0 = Corresponding port B pin configured as input

**NOTE:** Avoid glitches on port B pins by writing to the port B data register before changing data direction register B bits from 0 to 1.

Figure 15-7 shows the port B I/O logic.

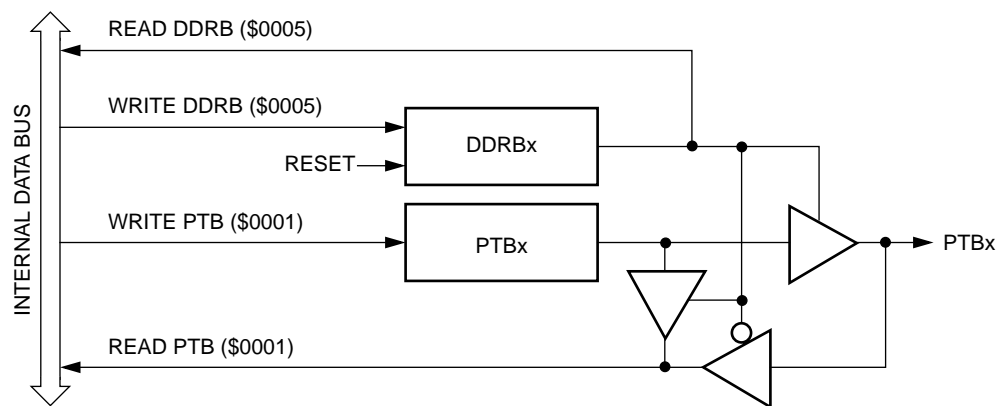

Figure 15-7. Port B I/O Circuit

When bit DDRBx is a logic 1, reading address \$0001 reads the PTBx data latch. When bit DDRBx is a logic 0, reading address \$0001 reads the voltage level on the pin. The data latch can always be written, regardless of the state of its data direction bit. [Table 15-4](#) summarizes the operation of the port B pins.

**Table 15-4. Port B Pin Functions**

DDRB Bit	PTB Bit	I/O Pin Mode	Accesses to DDRB	Accesses to PTB	
			Read/Write	Read	Write
0	X <sup>(1)</sup>	Input, Hi-Z <sup>(2)</sup>	DDRB7–DDRB0	Pin	PTB7–PTB0 <sup>(3)</sup>
1	X	Output	DDRB7–DDRB0	PTB7–PTB0	PTB7–PTB0

Notes:

1. X = Don't care
2. Hi-Z = High impedance
3. Writing affects data register, but does not affect input.

### 15.4.3 Port B Options

The PWM control register 1 (PWMCR1) selects the port B pins for PWM function or as standard I/O function. See [11.4.2 PWM Control Registers 1 and 2 \(PWMCR1:PWMCR2\)](#).

Address: \$0028

	Bit 7	6	5	4	3	2	1	Bit 0
Read:	PWM7E	PWM6E	PWM5E	PWM4E	PWM3E	PWM2E	PWM1E	PWM0E
Write:								
Reset:	0	0	0	0	0	0	0	0

**Figure 15-8. PWM Control Register 1 (PWMCR1)**

PWM7E–PWM0E — PWM Output Enable 7–0

Setting a bit to "1" will configure the corresponding PTBx/PWMx pin for PWM output function. Reset clears these bits.

- 1 = PTBx/PWMx pin configured as PWMx output pin
- 0 = PTBx/PWMx pin configured as standard I/O pin

## 15.5 Port C

Port C is an 6-bit special-function port that shares all six of its pins with the analog-to-digital converter (ADC) module.

### 15.5.1 Port C Data Register

The port C data register (PTC) contains a data latch for each of the seven port C pins.

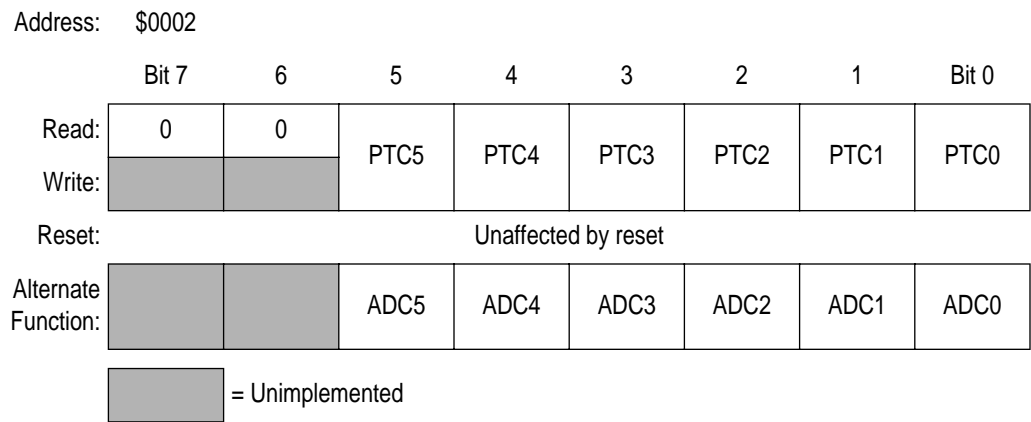

**Figure 15-9. Port C Data Register (PTC)**

#### PTC5–PTC0 — Port C Data Bits

These read/write bits are software-programmable. Data direction of each port C pin is under the control of the corresponding bit in data direction register C. Reset has no effect on port C data.

#### ADC5–ADC0 — Analog-to-Digital Input Bits

ADC5–ADC0 are pins used for the input channels to the analog-to-digital converter module. The channel select bits in the **ADC Status and Control Register** define which port C pin will be used as an ADC input and overrides any control from the port I/O logic by forcing that pin as the input to the analog circuitry.

**NOTE:** *Care must be taken when reading port C while applying analog voltages to ADC5–ADC0 pins. If the appropriate ADC channel is not enabled, excessive current drain may occur if analog voltages are applied to the PTCx/ADCx pin, while PTC is read as a digital input. Those ports not selected as analog input channels are considered digital I/O ports.*

15.5.2 Data Direction Register C

Data direction register C (DDRC) determines whether each port C pin is an input or an output. Writing a logic 1 to a DDRC bit enables the output buffer for the corresponding port C pin; a logic 0 disables the output buffer.

Address: \$0006

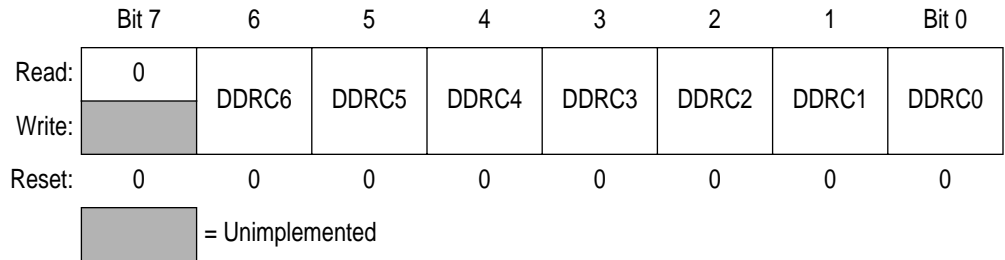

Figure 15-10. Data Direction Register C (DDRC)

DDRC6–DDRC0 — Data Direction Register C Bits

These read/write bits control port C data direction. Reset clears DDRC6–DDRC0, configuring all port C pins as inputs.

- 1 = Corresponding port C pin configured as output
- 0 = Corresponding port C pin configured as input

**NOTE:** Avoid glitches on port C pins by writing to the port C data register before changing data direction register C bits from 0 to 1.

Figure 15-11 shows the port C I/O logic.

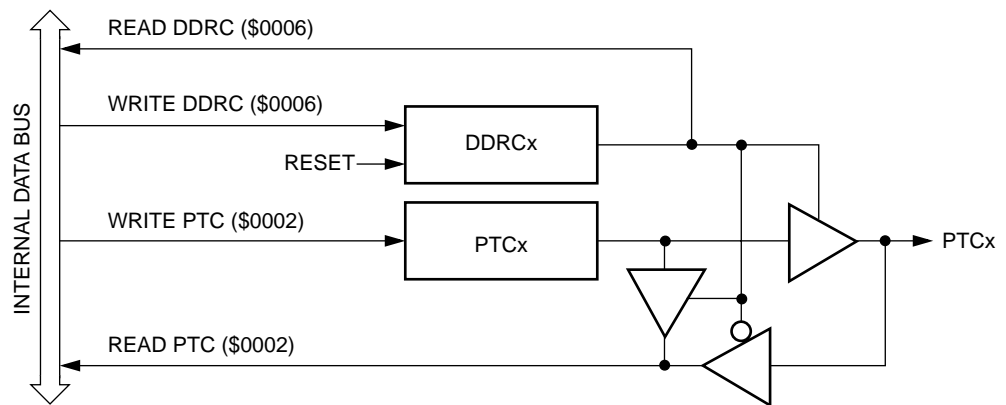

Figure 15-11. Port C I/O Circuit



When bit DDRCx is a logic 1, reading address \$0002 reads the PTCx data latch. When bit DDRCx is a logic 0, reading address \$0002 reads the voltage level on the pin. The data latch can always be written, regardless of the state of its data direction bit. [Table 15-5](#) summarizes the operation of the port C pins.

**Table 15-5. Port C Pin Functions**

PTCPUE Bit	DDRC Bit	PTC Bit	I/O Pin Mode	Accesses to DDRC	Accesses to PTC	
				Read/Write	Read	Write
0	0	X	Input, Hi-Z <sup>(2)</sup>	DDRC6–DDRC0	Pin	PTC6–PTC0 <sup>(3)</sup>
X	1	X	Output	DDRC6–DDRC0	PTC6–PTC0	PTC6–PTC0

Notes:

1. X = Don't care
2. Hi-Z = High impedance
3. Writing affects data register, but does not affect input.

### 15.5.3 Port C Options

The ADCH4–ADCH0 bits in the [ADC Status and Control Register](#) (ADSCR) defines which PTCx/ADCx pin is used as an ADC input and overrides any control from the port I/O logic by forcing that pin as the input to the analog circuitry. See [12.8.1 ADC Status and Control Register](#).

## 15.6 Port D

Port D is an 7-bit special-function port that shares one of its pins with the sync processor and two of its pins with the DDC12AB module.

**NOTE:** *PTD1 and PTD0 are 3.3V pins.*

### 15.6.1 Port D Data Register

The port D data register (PTD) contains a data latch for each of the eight port D pins.

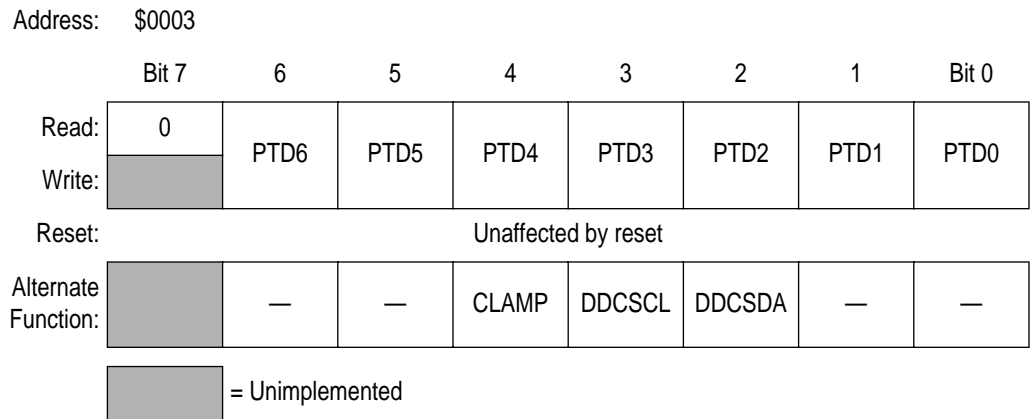

**Figure 15-12. Port D Data Register (PTD)**

#### PTD6–PTD0 — Port D Data Bits

These read/write bits are software-programmable. Data direction of each port D pin is under the control of the corresponding bit in data direction register D. Reset has no effect on port D data.

#### CLAMP — Sync Processor Clamp pulse output pin

The PTD4/CLAMP pin is the sync processor clamp pulse output pin. When the CLAMPE bit in the port D configuration register (PDCR) is clear, the PTD4/CLAMP pin is available for general-purpose I/O. See [15.6.3 Port D Options](#).

DDCSCL, DDCSDA — DDC12AB Data and Clock pins

The PTD3/DDCSCL and PTD2/DDCSDA pins are DDC12AB clock and data pins respectively. When the DDCSCLE and DDCDATE bits in the port D configuration register (PDCR) is clear, the PTD3/DDCSCL and PTD2/DDCSDA pins are available for general-purpose I/O. See [15.6.3 Port D Options](#).

15.6.2 Data Direction Register D

Data direction register D (DDRD) determines whether each port D pin is an input or an output. Writing a logic 1 to a DDRD bit enables the output buffer for the corresponding port D pin; a logic 0 disables the output buffer.

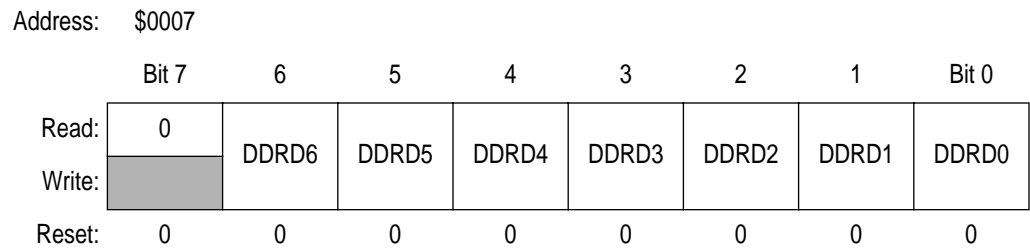

**Figure 15-13. Data Direction Register D (DDRD)**

DDRD6–DDRD0 — Data Direction Register D Bits

These read/write bits control port D data direction. Reset clears DDRD6–DDRD0, configuring all port D pins as inputs.

- 1 = Corresponding port D pin configured as output
- 0 = Corresponding port D pin configured as input

**NOTE:** *Avoid glitches on port D pins by writing to the port D data register before changing data direction register D bits from 0 to 1.*

[Figure 15-14](#) shows the port D I/O logic.

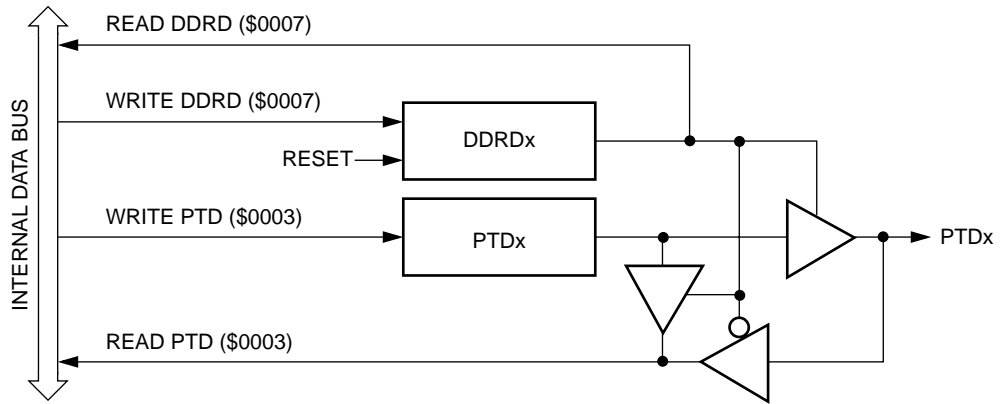

Figure 15-14. Port D I/O Circuit

When bit DDRDx is a logic 1, reading address \$0003 reads the PTDx data latch. When bit DDRDx is a logic 0, reading address \$0003 reads the voltage level on the pin. The data latch can always be written, regardless of the state of its data direction bit. Table 15-6 summarizes the operation of the port D pins.

Table 15-6. Port D Pin Functions

PTDPUE Bit	DDRD Bit	PTD Bit	I/O Pin Mode	Accesses to DDRD			Accesses to PTD	
				Read/Write		Read	Write	
0	0	X	Input, Hi-Z <sup>(2)</sup>	DDRD7–DDRD0		Pin	PTD7–PTD0 <sup>(3)</sup>	
X	1	X	Output	DDRD7–DDRD0		PTD7–PTD0	PTD7–PTD0	

Notes:

1. X = Don't care
2. Hi-Z = High impedance
3. Writing affects data register, but does not affect input.

15.6.3 Port D Options

The port D configuration register (PDCR) selects the port D pins for module function or as standard I/O function.

Address: \$0049

	Bit 7	6	5	4	3	2	1	Bit 0
Read:	0	0	0	CLAMPE	DDCSCLE	DDCDATE	0	0
Write:								
Reset:	0	0	0	0	0	0	0	0

= Unimplemented

**Figure 15-15. Port D Configuration Register (PDCR)**

**CLAMP — CLAMP Pin Enable**

This bit is set to configure the PTD4/CLAMP pin for sync processor clamp pulse output. Reset clears this bit.

- 1 = PTD4/CLAMP pin configured as CLAMP pin
- 0 = PTD4/CLAMP pin configured as standard I/O pin

**DDCSCLE — DDC Clock Pin Enable**

This bit is set to configure the PTD3/DDCSCL pin for DDCSCL function. Reset clears this bit.

- 1 = PTD3/DDCSCL pin configured as DDCSCL pin
- 0 = PTD3/DDCSCL pin configured as standard I/O port

**DDCDATE — DDC Data Pin Enable**

This bit is set to configure the PTD2/DDCSDA pin for DDCSDA function. Reset clears this bit.

- 1 = PTD2/DDCSDA pin configured as DDCSDA pin
- 0 = PTD2/DDCSDA pin configured as standard I/O port

## 15.7 Port E

Port E is a 3-bit special-function port that shares all of its pins with the sync processor.

### 15.7.1 Port E Data Register

The port E data register contains a data latch for each of the two port E pins.

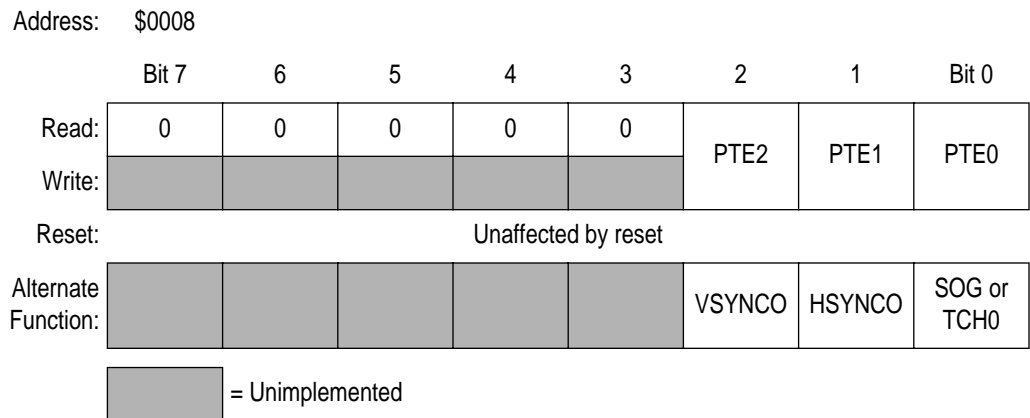

**Figure 15-16. Port E Data Register (PTE)**

#### PTE2 and PTE0 — Port E Data Bits

PTE2–PTE0 are read/write, software programmable bits. Data direction of each port E pin is under the control of the corresponding bit in data direction register E.

#### VSYNCO — Vsync Output

The PTE2/VSYNCO pin is the Vsync output from the sync processor. When the VSYNCOE is clear, the PTE2/VSYNCO pin is available for general-purpose I/O. See [15.7.3 Port E Options](#).

#### HSYNC — Hsync Output

The PTE1/HSYNCO pin is the Hsync output from the sync processor. When the HSYNCOE is clear, the PTE1/HSYNCO pin is available for general-purpose I/O. See [15.7.3 Port E Options](#).

SOG/TCH0 — SOG Output or TCH0 Input

The PTE0/SOG/TCH0 pin is the SOG input for the sync processor or the input capture of the TIM channel 0. See [15.7.3 Port E Options](#).

15.7.2 Data Direction Register E

Data direction register E (DDRE) determines whether each port E pin is an input or an output. Writing a logic 1 to a DDRE bit enables the output buffer for the corresponding port E pin; a logic 0 disables the output buffer.

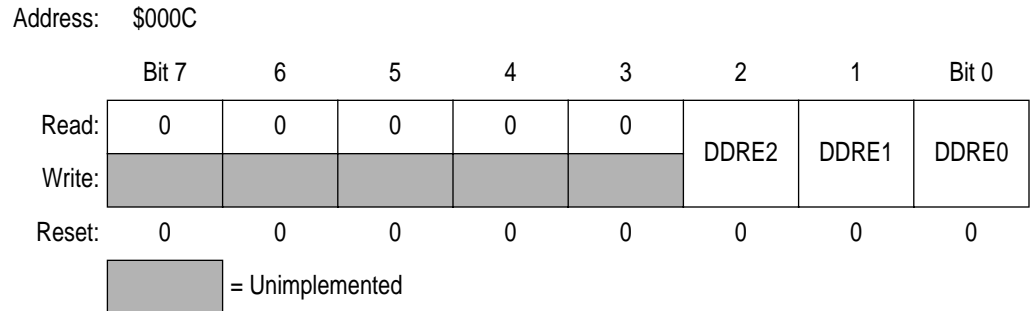

**Figure 15-17. Data Direction Register E (DDRE)**

DDRE2–DDRE0 — Data Direction Register E Bits

These read/write bits control port E data direction. Reset clears DDRE2–DDRE0, configuring all port E pins as inputs.

- 1 = Corresponding port E pin configured as output
- 0 = Corresponding port E pin configured as input

**NOTE:** *Avoid glitches on port E pins by writing to the port E data register before changing data direction register E bits from 0 to 1.*

[Figure 15-18](#) shows the port E I/O logic.

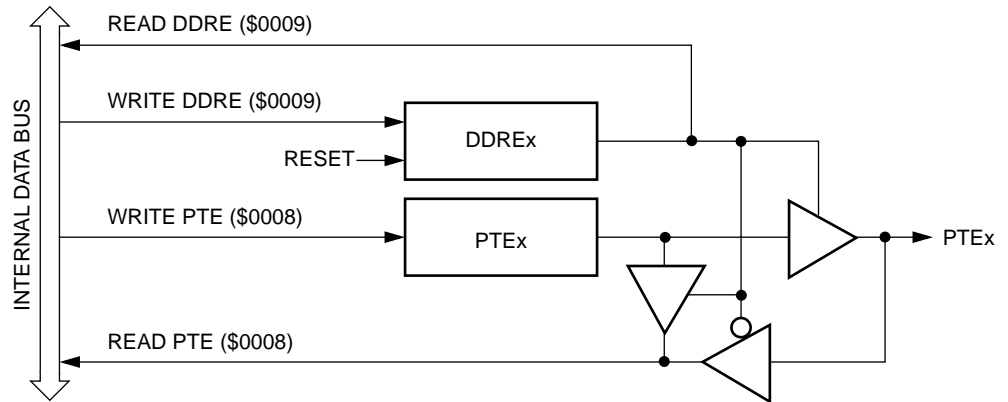

Figure 15-18. Port E I/O Circuit

When bit DDREx is a logic 1, reading address \$0008 reads the PTEx data latch. When bit DDREx is a logic 0, reading address \$0008 reads the voltage level on the pin. The data latch can always be written, regardless of the state of its data direction bit. Table 15-7 summarizes the operation of the port E pins.

Table 15-7. Port E Pin Functions

DDRE Bit	PTE Bit	I/O Pin Mode	Accesses to DDRE	Accesses to PTE	
			Read/Write	Read	Write
0	X <sup>(1)</sup>	Input, Hi-Z <sup>(2)</sup>	DDRE1–DDRE0	Pin	PTE1–PTE0 <sup>(3)</sup>
1	X	Output	DDRE1–DDRE0]	PTE1–PTE0	PTE1–PTE0

Notes:

1. X = Don't care
2. Hi-Z = High impedance
3. Writing affects data register, but does not affect input.



### 15.7.3 Port E Options

The configuration register 0 (CONFIG0) selects the port E pins for module function or as standard I/O function.

Address: \$001D

	Bit 7	6	5	4	3	2	1	Bit 0
Read:	HSYNCOE	VSYNCOE	SOGE	0	0	0	0	0
Write:								
Reset:	0	0	0	0	0	0	0	0

= Unimplemented

**Figure 15-19. Configuration Register 0 (CONFIG0)**

#### HSYNCOE — VSYNCO Enable

This bit is set to configure the PTE1/HSYNCO pin for HSYNCO output function. Reset clears this bit.

- 1 = PTE1/HSYNCO pin configured as HSYNCO pin
- 0 = PTE1/HSYNCO pin configured as standard I/O pin

#### VSYNCOE — VSYNCO Enable

This bit is set to configure the PTE2/VSYNCO pin for VSYNCO output function. Reset clears this bit.

- 1 = PTE2/VSYNCO pin configured as VSYNCO pin
- 0 = PTE2/VSYNCO pin configured as standard I/O pin

#### SOGE — SOG Enable

This bit is set to configure the PTE0/SOG/TCH0 pin for SOG output function. Reset clears this bit.

- 1 = PTE0/SOG/TCH0 pin configured as SOG pin
- 0 = PTE0/SOG/TCH0 pin configured as standard I/O or TCH0 pin.  
TCH0 function is configured by ELS0B and ELS0A bits in TSC0 (bits 3 and 2 in \$0010).



## Section 16. External Interrupt (IRQ)

### 16.1 Contents

16.2	Introduction . . . . .	211
16.3	Features . . . . .	211
16.4	Functional Description . . . . .	212
16.5	$\overline{\text{IRQ}}$ Pin . . . . .	214
16.6	IRQ Module During Break Interrupts . . . . .	215
16.7	IRQ Status and Control Register . . . . .	215

### 16.2 Introduction

The IRQ (external interrupt) module provides a maskable interrupt input.

### 16.3 Features

Features of the IRQ module include:

- A dedicated external interrupt pin ( $\overline{\text{IRQ}}$ )
- IRQ interrupt control bits
- Hysteresis buffer
- Programmable edge-only or edge and level interrupt sensitivity
- Automatic interrupt acknowledge
- Internal pullup resistor

## 16.4 Functional Description

A logic 0 applied to the external interrupt pin can latch a CPU interrupt request. **Figure 16-1** shows the structure of the IRQ module.

Interrupt signals on the  $\overline{\text{IRQ}}$  pin are latched into the IRQ latch. An interrupt latch remains set until one of the following actions occurs:

- Vector fetch — A vector fetch automatically generates an interrupt acknowledge signal that clears the latch that caused the vector fetch.
- Software clear — Software can clear an interrupt latch by writing to the appropriate acknowledge bit in the interrupt status and control register (INTSCR). Writing a logic 1 to the ACK bit clears the IRQ latch.
- Reset — A reset automatically clears the interrupt latch.

The external interrupt pin is falling-edge-triggered and is software-configurable to be either falling-edge or falling-edge and low-level-triggered. The MODE bit in the INTSCR controls the triggering sensitivity of the  $\overline{\text{IRQ}}$  pin.

When an interrupt pin is edge-triggered only, the interrupt remains set until a vector fetch, software clear, or reset occurs.

When an interrupt pin is both falling-edge and low-level-triggered, the interrupt remains set until both of the following occur:

- Vector fetch or software clear
- Return of the interrupt pin to logic 1

The vector fetch or software clear may occur before or after the interrupt pin returns to logic 1. As long as the pin is low, the interrupt request remains pending. A reset will clear the latch and the MODE control bit, thereby clearing the interrupt even if the pin stays low.

When set, the IMASK bit in the INTSCR mask all external interrupt requests. A latched interrupt request is not presented to the interrupt priority logic unless the IMASK bit is clear.

**NOTE:** The interrupt mask (I) in the condition code register (CCR) masks all interrupt requests, including external interrupt requests.

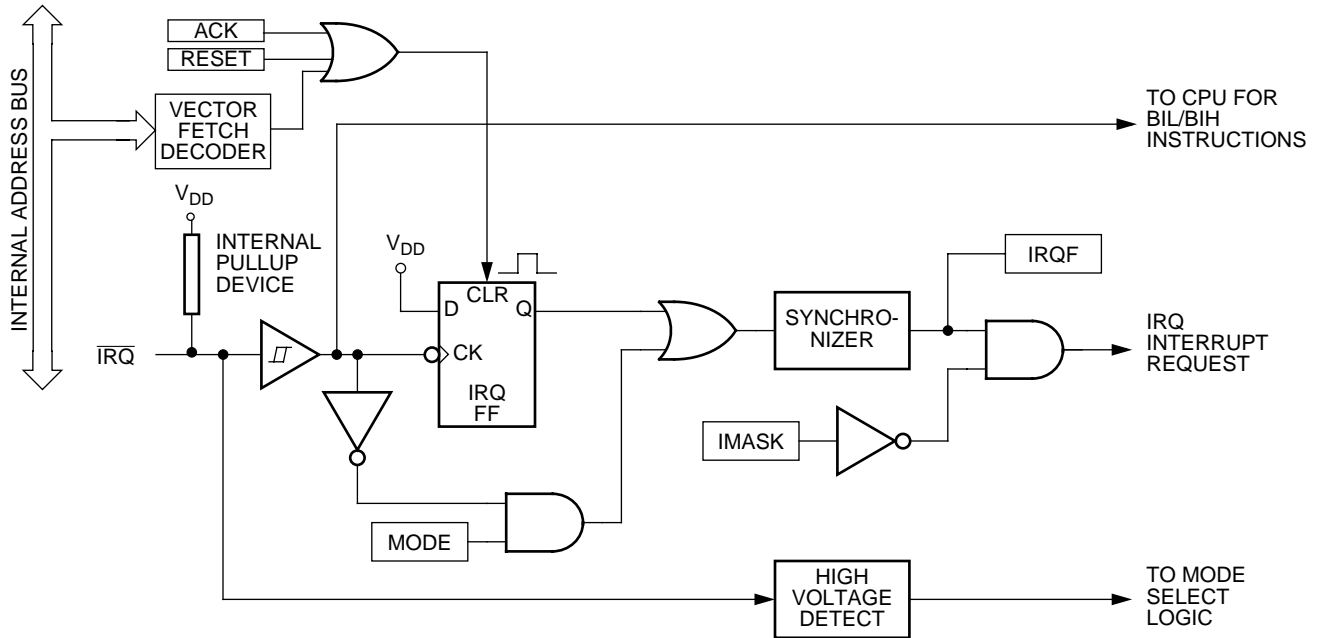

Figure 16-1. IRQ Module Block Diagram

Table 16-1. IRQ I/O Register Summary

Addr	Register Name	Bit 7	6	5	4	3	2	1	Bit 0	
\$001E	IRQ Status and Control Register (INTSCR)	Read:	0	0	0	0	IRQF	0	IMASK	MODE
		Write:						ACK		
		Reset:	0	0	0	0	0	0	0	0

= Unimplemented

16.5  $\overline{\text{IRQ}}$  Pin

A logic 0 on the  $\overline{\text{IRQ}}$  pin can latch an interrupt request into the IRQ latch. A vector fetch, software clear, or reset clears the IRQ latch.

If the MODE bit is set, the  $\overline{\text{IRQ}}$  pin is both falling-edge-sensitive and low-level-sensitive. With MODE set, both of the following actions must occur to clear IRQ:

- Vector fetch or software clear — A vector fetch generates an interrupt acknowledge signal to clear the latch. Software may generate the interrupt acknowledge signal by writing a logic 1 to the ACK bit in the interrupt status and control register (INTSCR). The ACK bit is useful in applications that poll the  $\overline{\text{IRQ}}$  pin and require software to clear the IRQ latch. Writing to the ACK bit prior to leaving an interrupt service routine can also prevent spurious interrupts due to noise. Setting ACK does not affect subsequent transitions on the  $\overline{\text{IRQ}}$  pin. A falling edge that occurs after writing to the ACK bit another interrupt request. If the IRQ mask bit, IMASK, is clear, the CPU loads the program counter with the vector address at locations \$FFFA and \$FFFB.
- Return of the  $\overline{\text{IRQ}}$  pin to logic 1 — As long as the  $\overline{\text{IRQ}}$  pin is at logic 0, IRQ remains active.

The vector fetch or software clear and the return of the  $\overline{\text{IRQ}}$  pin to logic 1 may occur in any order. The interrupt request remains pending as long as the  $\overline{\text{IRQ}}$  pin is at logic 0. A reset will clear the latch and the MODE control bit, thereby clearing the interrupt even if the pin stays low.

If the MODE bit is clear, the  $\overline{\text{IRQ}}$  pin is falling-edge-sensitive only. With MODE clear, a vector fetch or software clear immediately clears the IRQ latch.

The IRQF bit in the INTSCR register can be used to check for pending interrupts. The IRQF bit is not affected by the IMASK bit, which makes it useful in applications where polling is preferred.

Use the BIH or BIL instruction to read the logic level on the  $\overline{\text{IRQ}}$  pin.

**NOTE:** *When using the level-sensitive interrupt trigger, avoid false interrupts by masking interrupt requests in the interrupt routine.*

## 16.6 IRQ Module During Break Interrupts

The BCFE bit in the SIM break flag control register (SBFCR) enables software to clear the latch during the break state. See [Section 18. Break Module \(BRK\)](#).

To allow software to clear the IRQ latch during a break interrupt, write a logic 1 to the BCFE bit. If a latch is cleared during the break state, it remains cleared when the MCU exits the break state.

To protect CPU interrupt flags during the break state, write a logic 0 to the BCFE bit. With BCFE at logic 0 (its default state), writing to the ACK bit in the IRQ status and control register during the break state has no effect on the IRQ interrupt flags.

## 16.7 IRQ Status and Control Register

The IRQ status and control register (INTSCR) controls and monitors operation of the IRQ module. The INTSCR:

- Shows the state of the IRQ flag
- Clears the IRQ latch
- Masks IRQ interrupt request
- Controls triggering sensitivity of the  $\overline{\text{IRQ}}$  interrupt pin

External Interrupt (IRQ)

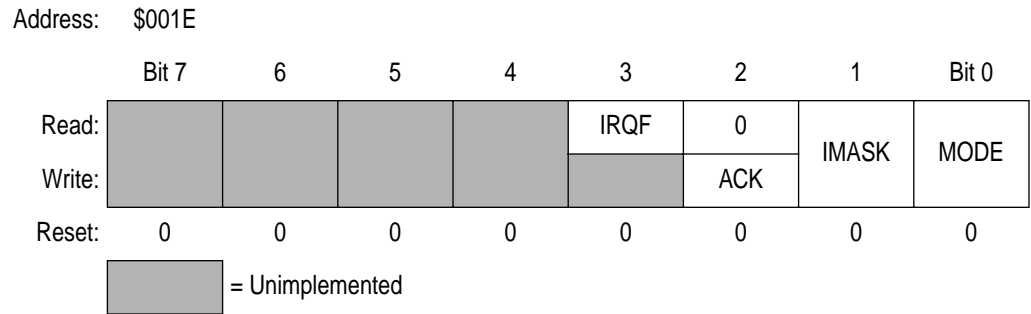

Figure 16-2. IRQ Status and Control Register (INTSCR)

IRQF — IRQ Flag Bit

This read-only status bit is high when the IRQ interrupt is pending.

- 1 =  $\overline{\text{IRQ}}$  interrupt pending
- 0 =  $\overline{\text{IRQ}}$  interrupt not pending

ACK — IRQ Interrupt Request Acknowledge Bit

Writing a logic 1 to this write-only bit clears the IRQ latch. ACK always reads as logic 0. Reset clears ACK.

IMASK — IRQ Interrupt Mask Bit

Writing a logic 1 to this read/write bit disables IRQ interrupt requests. Reset clears IMASK.

- 1 = IRQ interrupt requests disabled
- 0 = IRQ interrupt requests enabled

MODE — IRQ Edge/Level Select Bit

This read/write bit controls the triggering sensitivity of the  $\overline{\text{IRQ}}$  pin. Reset clears MODE.

- 1 =  $\overline{\text{IRQ}}$  interrupt requests on falling edges and low levels
- 0 =  $\overline{\text{IRQ}}$  interrupt requests on falling edges only



## Section 17. Computer Operating Properly (COP)

### 17.1 Contents

17.2	Introduction	217
17.3	Functional Description	218
17.4	I/O Signals	219
17.4.1	OSCCLK	219
17.4.2	STOP Instruction	219
17.4.3	COPCTL Write	219
17.4.4	Power-On Reset	219
17.4.5	Internal Reset	220
17.4.6	Reset Vector Fetch	220
17.4.7	COPD (COP Disable)	220
17.4.8	COPRS (COP Rate Select)	220
17.5	COP Control Register	221
17.6	Interrupts	221
17.7	Monitor Mode	221
17.8	Low-Power Modes	221
17.8.1	Wait Mode	222
17.8.2	Stop Mode	222
17.9	COP Module During Break Mode	222

### 17.2 Introduction

The computer operating properly (COP) module contains a free-running counter that generates a reset if allowed to overflow. The COP module helps software recover from runaway code. Prevent a COP reset by clearing the COP counter periodically. The COP module can be disabled through the COPD bit in the CONFIG register.

17.3 Functional Description

Figure 17-1 shows the structure of the COP module.

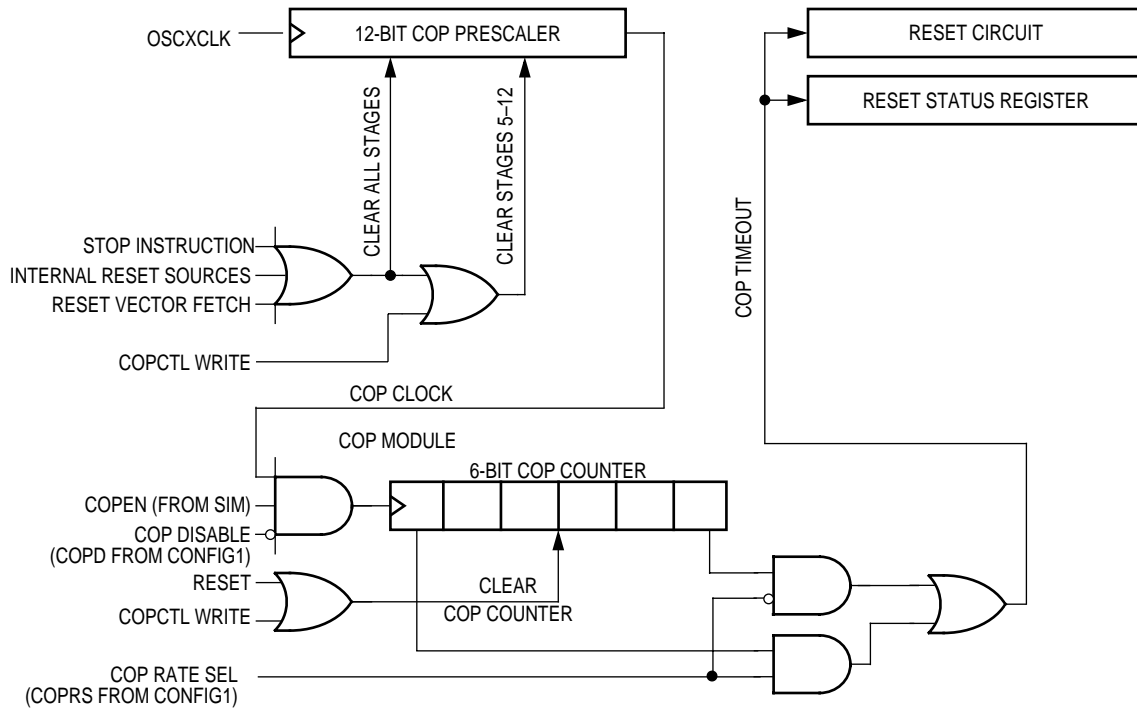

Figure 17-1. COP Block Diagram

The COP counter is a free-running 6-bit counter preceded by a 12-bit prescaler counter. If not cleared by software, the COP counter overflows and generates an asynchronous reset after  $2^{18} - 2^4$  or  $2^{13} - 2^4$  OSCXCLK cycles, depending on the state of the COP rate select bit, COPRS, in configuration register 1. With a  $2^{18} - 2^4$  OSCXCLK cycle overflow option, a 24MHz crystal gives a COP timeout period of 10.922ms. Writing any value to location \$FFFF before an overflow occurs prevents a COP reset by clearing the COP counter and stages 12 through 5 of the prescaler.

**NOTE:** Service the COP immediately after reset and before entering or after exiting stop mode to guarantee the maximum time before the first COP counter overflow.

A COP reset pulls the  $\overline{\text{RST}}$  pin low for 32 OSCXCLK cycles and sets the COP bit in the SIM reset status register (SRSR).

In monitor mode, the COP is disabled if the  $\overline{\text{RST}}$  pin or the  $\overline{\text{IRQ1}}$  is held at  $V_{\text{TST}}$ . During the break state,  $V_{\text{TST}}$  on the  $\overline{\text{RST}}$  pin disables the COP.

**NOTE:** *Place COP clearing instructions in the main program and not in an interrupt subroutine. Such an interrupt subroutine could keep the COP from generating a reset even while the main program is not working properly.*

## 17.4 I/O Signals

The following paragraphs describe the signals shown in [Figure 17-1](#).

### 17.4.1 OSCXCLK

OSCXCLK is the crystal oscillator output signal. OSCXCLK frequency is equal to the crystal frequency.

### 17.4.2 STOP Instruction

The STOP instruction clears the COP prescaler.

### 17.4.3 COPCTL Write

Writing any value to the COP control register (COPCTL) ([see 17.5 COP Control Register](#)) clears the COP counter and clears bits 12 through 5 of the prescaler. Reading the COP control register returns the low byte of the reset vector.

### 17.4.4 Power-On Reset

The power-on reset (POR) circuit clears the COP prescaler 4096 OSCXCLK cycles after power-up.

17.4.5 Internal Reset

An internal reset clears the COP prescaler and the COP counter.

17.4.6 Reset Vector Fetch

A reset vector fetch occurs when the vector address appears on the data bus. A reset vector fetch clears the COP prescaler.

17.4.7 COPD (COP Disable)

The COPD signal reflects the state of the COP disable bit (COPD) in the configuration register 1 (see Figure 17-2).

17.4.8 COPRS (COP Rate Select)

The COPRS signal reflects the state of the COP rate select bit (COPRS) in the configuration register 1 (see Figure 17-2).

Address: \$001F

	Bit 7	6	5	4	3	2	1	Bit 0
Read:	0	0	0	0	SSREC	COPRS	STOP	COPD
Write:								
Reset:	0	0	0	0	0	0	0	0

= Unimplemented

Figure 17-2. Configuration Register 1 (CONFIG1)

COPRS — COP Rate Select Bit

COPRS selects the COP timeout period. Reset clears COPRS.

1 = COP timeout period =  $2^{13} - 2^4$  OSCXCLK cycles

0 = COP timeout period =  $2^{18} - 2^4$  OSCXCLK cycles

COPD — COP Disable Bit

COPD disables the COP module.

1 = COP module disabled

0 = COP module enabled

## 17.5 COP Control Register

The COP control register is located at address \$FFFF and overlaps the reset vector. Writing any value to \$FFFF clears the COP counter and starts a new timeout period. Reading location \$FFFF returns the low byte of the reset vector.

Address:	\$FFFF
	Bit 7      6      5      4      3      2      1      Bit 0
Read:	Low byte of reset vector
Write:	Clear COP counter
Reset:	Unaffected by reset

**Figure 17-3. COP Control Register (COPCTL)**

## 17.6 Interrupts

The COP does not generate CPU interrupt requests.

## 17.7 Monitor Mode

When monitor mode is entered with  $V_{TST}$  on the  $\overline{IRQ}$  pin, the COP is disabled as long as  $V_{TST}$  remains on the  $\overline{IRQ}$  pin or the  $\overline{RST}$  pin. When monitor mode is entered by having blank reset vectors and not having  $V_{TST}$  on the  $\overline{IRQ}$  pin, the COP is automatically disabled until a POR occurs.

## 17.8 Low-Power Modes

The WAIT and STOP instructions put the MCU in low power-consumption standby modes.

### 17.8.1 Wait Mode

The COP remains active during wait mode. To prevent a COP reset during wait mode, periodically clear the COP counter in a CPU interrupt routine.

### 17.8.2 Stop Mode

Stop mode turns off the OSCXCLK input to the COP and clears the COP prescaler. Service the COP immediately before entering or after exiting stop mode to ensure a full COP timeout period after entering or exiting stop mode.

To prevent inadvertently turning off the COP with a STOP instruction, a configuration option is available that disables the STOP instruction. When the STOP bit in the configuration register has the STOP instruction is disabled, execution of a STOP instruction results in an illegal opcode reset.

## 17.9 COP Module During Break Mode

The COP is disabled during a break interrupt when  $V_{TST}$  is present on the  $\overline{RST}$  pin.

## Section 18. Break Module (BRK)

### 18.1 Contents

18.2	Introduction . . . . .	223
18.3	Features . . . . .	224
18.4	Functional Description . . . . .	224
18.4.1	Flag Protection During Break Interrupts . . . . .	226
18.4.2	CPU During Break Interrupts . . . . .	226
18.4.3	TIM During Break Interrupts . . . . .	226
18.4.4	COP During Break Interrupts . . . . .	226
18.5	Low-Power Modes . . . . .	226
18.5.1	Wait Mode . . . . .	226
18.5.2	Stop Mode . . . . .	227
18.6	Break Module Registers . . . . .	227
18.6.1	Break Status and Control Register . . . . .	227
18.6.2	Break Address Registers . . . . .	228
18.6.3	SIM Break Status Register . . . . .	228
18.6.4	SIM Break Flag Control Register . . . . .	230

### 18.2 Introduction

This section describes the break module. The break module can generate a break interrupt that stops normal program flow at a defined address to enter a background program.

## 18.3 Features

Features of the break module include:

- Accessible input/output (I/O) registers during the break interrupt
- CPU-generated break interrupts
- Software-generated break interrupts
- COP disabling during break interrupts

## 18.4 Functional Description

When the internal address bus matches the value written in the break address registers, the break module issues a breakpoint signal to the CPU. The CPU then loads the instruction register with a software interrupt instruction (SWI) after completion of the current CPU instruction. The program counter vectors to \$FFFC and \$FFFD (\$FEFC and \$FEFD in monitor mode).

The following events can cause a break interrupt to occur:

- A CPU-generated address (the address in the program counter) matches the contents of the break address registers.
- Software writes a logic 1 to the BRKA bit in the break status and control register.

When a CPU-generated address matches the contents of the break address registers, the break interrupt begins after the CPU completes its current instruction. A return-from-interrupt instruction (RTI) in the break routine ends the break interrupt and returns the MCU to normal operation. [Figure 18-1](#) shows the structure of the break module.



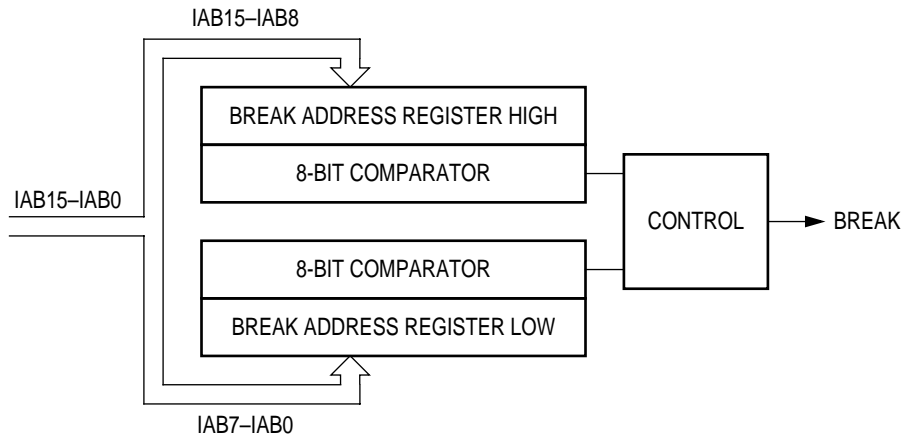

Figure 18-1. Break Module Block Diagram

Table 18-1. Break Module I/O Register Summary

Addr.	Register Name	Bit 7	6	5	4	3	2	1	Bit 0	
\$FE00	SIM Break Status Register (SBSR)	Read:	R	R	R	R	R	SBSW	R	
		Write:						Note		
		Reset:	0	0	0	0	0	0	0	
\$FE03	SIM Break Flag Control Register (SBFCR)	Read:	BCFE	R	R	R	R	R	R	
		Write:								
		Reset:	0							
\$FE0C	Break Address Register High (BRKH)	Read:	Bit 15	14	13	12	11	10	9	Bit 8
		Write:								
		Reset:	0	0	0	0	0	0	0	0
\$FE0D	Break Address Register Low (BRKL)	Read:	Bit 7	6	5	4	3	2	1	Bit 0
		Write:								
		Reset:	0	0	0	0	0	0	0	0
\$FE0E	Break Status and Control Register (BRKSCR)	Read:	BRKE	BRKA	0	0	0	0	0	0
		Write:								
		Reset:	0	0	0	0	0	0	0	0

Note: Writing a logic 0 clears SBSW.  = Unimplemented R = Reserved

### 18.4.1 Flag Protection During Break Interrupts

The BCFE bit in the SIM break flag control register (SBFCR) enables software to clear status bits during the break state.

### 18.4.2 CPU During Break Interrupts

The CPU starts a break interrupt by:

- Loading the instruction register with the SWI instruction
- Loading the program counter with \$FFFC and \$FFFD (\$FEFC and \$FEFD in monitor mode)

The break interrupt begins after completion of the CPU instruction in progress. If the break address register match occurs on the last cycle of a CPU instruction, the break interrupt begins immediately.

### 18.4.3 TIM During Break Interrupts

A break interrupt stops the timer counters.

### 18.4.4 COP During Break Interrupts

The COP is disabled during a break interrupt when  $V_{TST}$  is present on the  $\overline{RST}$  pin.

## 18.5 Low-Power Modes

The WAIT and STOP instructions put the MCU in low power-consumption standby modes.

### 18.5.1 Wait Mode

If enabled, the break module is active in wait mode. In the break routine, the user can subtract one from the return address on the stack if SBSW is set (see [Section 7. System Integration Module \(SIM\)](#)). Clear the SBSW bit by writing logic 0 to it.

18.5.2 Stop Mode

A break interrupt causes exit from stop mode and sets the SBSW bit in the break status register.

18.6 Break Module Registers

These registers control and monitor operation of the break module:

- Break status and control register (BRKSCR)
- Break address register high (BRKH)
- Break address register low (BRKL)
- SIM Break status register (SBSR)
- SIM Break flag control register (SBFCR)

18.6.1 Break Status and Control Register

The break status and control register (BRKSCR) contains break module enable and status bits.

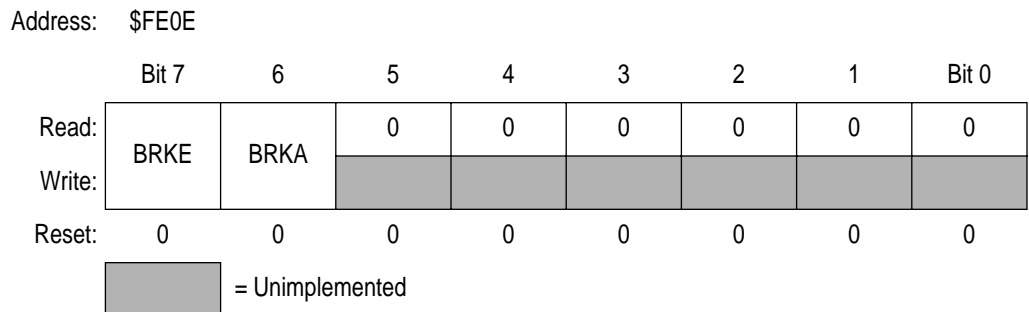

Figure 18-2. Break Status and Control Register (BRKSCR)

BRKE — Break Enable Bit

This read/write bit enables breaks on break address register matches. Clear BRKE by writing a logic 0 to bit 7. Reset clears the BRKE bit.

- 1 = Breaks enabled on 16-bit address match
- 0 = Breaks disabled on 16-bit address match

BRKA — Break Active Bit

This read/write status and control bit is set when a break address match occurs. Writing a logic 1 to BRKA generates a break interrupt. Clear BRKA by writing a logic 0 to it before exiting the break routine. Reset clears the BRKA bit.

- 1 = (When read) Break address match
- 0 = (When read) No break address match

18.6.2 Break Address Registers

The break address registers (BRKH and BRKL) contain the high and low bytes of the desired breakpoint address. Reset clears the break address registers.

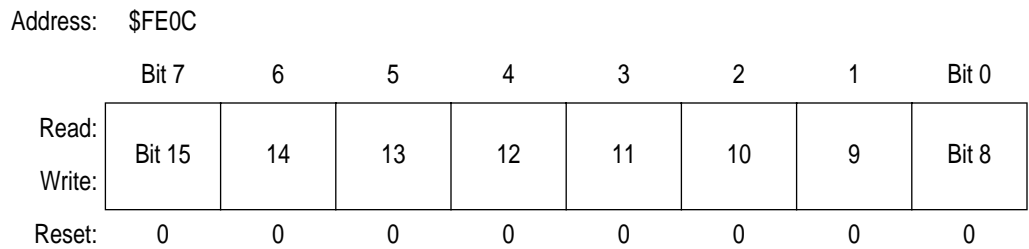

Figure 18-3. Break Address Register High (BRKH)

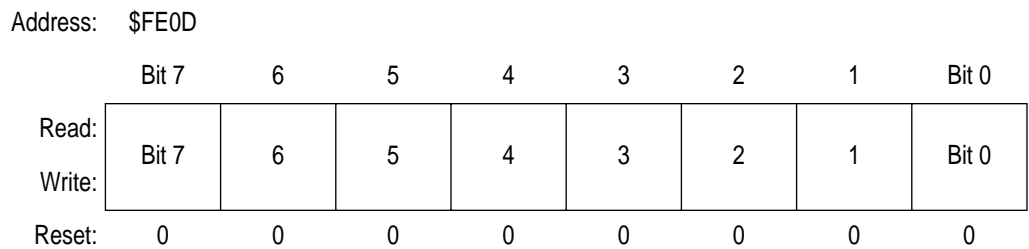
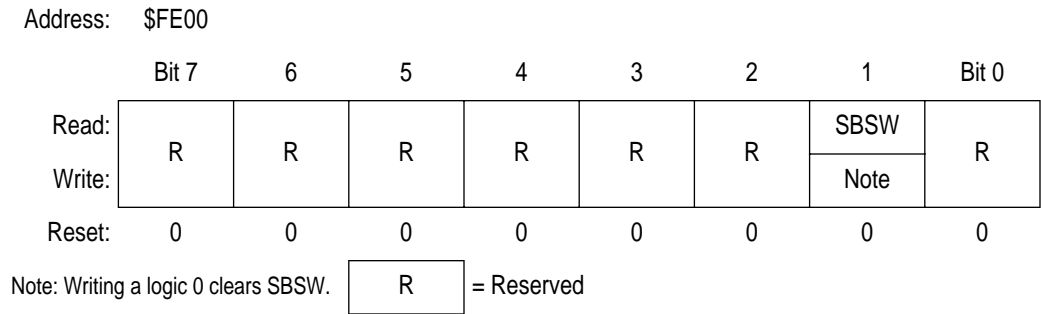

Figure 18-4. Break Address Register Low (BRKL)

18.6.3 SIM Break Status Register

The SIM break status register (SBSR) contains a flag to indicate that a break caused an exit from wait mode. The flag is useful in applications requiring a return to wait mode after exiting from a break interrupt.



**Figure 18-5. SIM Break Status Register (SBSR)**

**SBSW — SIM Break Stop/Wait Bit**

This status bit is useful in applications requiring a return to wait or stop mode after exiting from a break interrupt. Clear SBSW by writing a logic 0 to it. Reset clears SBSW.

- 1 = Stop mode or wait mode was exited by break interrupt
- 0 = Stop mode or wait mode was not exited by break interrupt

SBSW can be read within the break interrupt routine. The user can modify the return address on the stack by subtracting one from it. The following code is an example.

```

;This code works if the H register has been pushed onto the stack in the break
;service routine software. This code should be executed at the end of the break
;service routine software.

HIBYTE EQU 5
LOBYTE EQU 6
; If not SBSW, do RTI
BRCLR SBSW,SBSR, RETURN ;See if wait mode or stop mode was exited by
;break.
TST LOBYTE,SP ;If RETURNLO is not zero,
BNE DOLO ;then just decrement low byte.
DEC HIBYTE,SP ;Else deal with high byte, too.
DOLO DEC LOBYTE,SP ;Point to WAIT/STOP opcode.
RETURN PULH ;Restore H register.
RTI
    
```

18.6.4 SIM Break Flag Control Register

The SIM break flag control register (SBFCR) contains a bit that enables software to clear status bits while the MCU is in a break state.

Address: \$FE03

	Bit 7	6	5	4	3	2	1	Bit 0
Read:	BCFE	R	R	R	R	R	R	R
Write:	BCFE	R	R	R	R	R	R	R
Reset:	0							

R = Reserved

**Figure 18-6. SIM Break Flag Control Register (SBFCR)**

**BCFE — Break Clear Flag Enable Bit**

This read/write bit enables software to clear status bits by accessing status registers while the MCU is in a break state. To clear status bits during the break state, the BCFE bit must be set.

1 = Status bits clearable during break

0 = Status bits not clearable during break

## Section 19. Electrical Specifications

### 19.1 Contents

19.2	Introduction . . . . .	231
19.3	Absolute Maximum Ratings . . . . .	232
19.4	Functional Operating Range. . . . .	233
19.5	Thermal Characteristics . . . . .	233
19.6	DC Electrical Characteristics . . . . .	234
19.7	Control Timing . . . . .	235
19.8	Oscillator Characteristics . . . . .	235
19.9	ADC Characteristics . . . . .	236
19.10	Timer Interface Module Characteristics . . . . .	237
19.11	Sync Processor Timing. . . . .	237
19.12	DDC12AB Timing . . . . .	238
19.12.1	DDC12AB Interface Input Signal Timing . . . . .	238
19.12.2	DDC12AB Interface Output Signal Timing . . . . .	238

### 19.2 Introduction

This section contains electrical and timing specifications.

### 19.3 Absolute Maximum Ratings

Maximum ratings are the extreme limits to which the MCU can be exposed without permanently damaging it.

**NOTE:** *This device is not guaranteed to operate properly at the maximum ratings. Refer to **19.6 DC Electrical Characteristics** for guaranteed operating conditions.*

Characteristic	Symbol	Value	Unit
Supply Voltage	$V_{DD}$	-0.3 to +5.5	V
Input Voltage	$V_{IN}$	$V_{SS}-0.3$ to $V_{DD}+0.3$	V
Maximum Current Per Pin Excluding $V_{DD}$ and $V_{SS}$	I	±25	mA
Storage Temperature	$T_{STG}$	-55 to +150	°C
Maximum Current Out of $V_{SS}$	$I_{MVSS}$	100	mA
Maximum Current Into $V_{DD}$	$I_{MVDD}$	100	mA

NOTE:

1. Voltages referenced to  $V_{SS}$ .

**NOTE:** *This device contains circuitry to protect the inputs against damage due to high static voltages or electric fields; however, it is advised that normal precautions be taken to avoid application of any voltage higher than maximum-rated voltages to this high-impedance circuit. For proper operation, it is recommended that  $V_{IN}$  and  $V_{OUT}$  be constrained to the range  $V_{SS} \leq (V_{IN} \text{ or } V_{OUT}) \leq V_{DD}$ . Reliability of operation is enhanced if unused inputs are connected to an appropriate logic voltage level (for example, either  $V_{SS}$  or  $V_{DD}$ .)*



## 19.4 Functional Operating Range

Characteristic	Symbol	Value	Unit
Operating Temperature Range	$T_A$	0 to 85	°C
Operating Voltage Range	$V_{DD}$	4.5 to 5.5	V

## 19.5 Thermal Characteristics

Characteristic	Symbol	Value	Unit
Thermal Resistance QFP (44 Pins) SDIP (42 Pins)	$\theta_{JA}$	95 60	°C/W
I/O Pin Power Dissipation	$P_{I/O}$	User Determined	W
Power Dissipation <sup>(1)</sup>	$P_D$	$P_D = (I_{DD} \times V_{DD}) + P_{I/O} =$ $K/(T_J + 273 \text{ °C})$	W
Constant <sup>(2)</sup>	K	$P_D \times (T_A + 273 \text{ °C})$ $+ P_D^2 \times \theta_{JA}$	W/°C
Average Junction Temperature	$T_J$	$T_A + (P_D \times \theta_{JA})$	°C
Maximum Junction Temperature	$T_{JM}$	100	°C

NOTES:

1. Power dissipation is a function of temperature.
2. K is a constant unique to the device. K can be determined for a known  $T_A$  and measured  $P_D$ . With this value of K,  $P_D$  and  $T_J$  can be determined for any value of  $T_A$ .

Electrical Specifications

19.6 DC Electrical Characteristics

Characteristic	Symbol	Min	Typ <sup>(2)</sup>	Max	Unit
Output High Voltage ( $I_{LOAD} = -2.0\text{mA}$ ) All I/O Pins (except PTD0, PTD1, OSC2)	$V_{OH}$	$V_{DD} - 0.8$	—	—	V
PTD0, PTD1, OSC2		$\frac{2}{3}V_{DD} - 0.8$	—	—	
Output Low Voltage ( $I_{LOAD} = 1.6\text{mA}$ ) All I/O Pins (except PTD0, PTD1, OSC2) PTD0, PTD1, OSC2	$V_{OL}$	— —	— —	0.4 0.4	V
Input High Voltage All ports (except PTD0, PTD1), $\overline{IRQ}$ , $\overline{RST}$ VSYNC, HSYNC	$V_{IH}$	$0.7 \times V_{DD}$ 2.0	— —	$V_{DD}$ $V_{DD}$	V
PTD0, PTD1, OSC1		$0.7 \times \frac{2}{3}V_{DD}$	—	$\frac{2}{3}V_{DD}$	
Input Low Voltage All ports (except PTD0, PTD1), $\overline{IRQ}$ , $\overline{RST}$ VSYNC, HSYNC	$V_{IL}$	$V_{SS}$	—	$0.2 \times V_{DD}$	V
PTD0, PTD1, OSC1		$V_{SS}$	—	0.8	
		$V_{SS}$	—	$0.2 \times \frac{2}{3}V_{DD}$	
$V_{DD}$ Supply Current Run <sup>(3)</sup> Wait <sup>(4)</sup> Stop <sup>(5)</sup> 0°C to 85°C	$I_{DD}$	—	8	12	mA
—		—	4	8	
—		—	2	5	
—		—	—	—	
I/O Ports Hi-Z Leakage Current	$I_{IL}$	—	—	±10	µA
Input Current	$I_{IN}$	—	—	±1	µA
Capacitance Ports (as Input or Output)	$C_{OUT}$ $C_{IN}$	— —	— —	12 8	pF
POR ReArm Voltage <sup>(6)</sup>	$V_{POR}$	0	—	100	mV
POR Rise Time Ramp Rate <sup>(7)</sup>	$R_{POR}$	0.035	—	—	V/ms
Monitor Mode Entry Voltage	$V_{TST}$	$V_{DD} + 2.5$	—	8	V
Pull-up Resistor $\overline{RST}$ , $\overline{IRQ}$	$R_{PU}$	20	45	65	kΩ
Low-Voltage Inhibit, trip falling voltage	$V_{TRIPF}$	3.4	3.6	3.8	V
Low-Voltage Inhibit, trip rising voltage	$V_{TRIPR}$	3.6	3.8	4.0	V
Low-Voltage Inhibit Reset/Recover Hysteresis	$V_{HYS}$	—	200	—	mV
RAM data retention voltage	$V_{RDR}$	2	—	—	V

Characteristic	Symbol	Min	Typ <sup>(2)</sup>	Max	Unit
----------------	--------	-----	--------------------	-----	------

NOTES:

1.  $V_{DD} = 5.0 \text{ Vdc} \pm 10\%$ ,  $V_{SS} = 0 \text{ Vdc}$ ,  $T_A = T_L$  to  $T_H$ , unless otherwise noted.
2. Typical values reflect average measurements at midpoint of voltage range, 25 °C only.
3. Run (operating)  $I_{DD}$  measured using external square wave clock source. All inputs 0.2 V from rail. No dc loads. Less than 100 pF on all outputs.  $C_L = 15 \text{ pF}$  on OSC2. All ports configured as inputs. OSC2 capacitance linearly affects run  $I_{DD}$ . Measured with all modules enabled.
4. Wait  $I_{DD}$  measured using external square wave clock source ( $f_{OSCCLK} = 24\text{MHz}$ ); all inputs 0.2 V from rail; no dc loads; less than 100 pF on all outputs.  $C_L = 15\text{pF}$  on OSC2; all ports configured as inputs; OSC2 capacitance linearly affects wait  $I_{DD}$ .
5. STOP  $I_{DD}$  measured with OSC1 grounded; no port pins sourcing current.
6. Maximum is highest voltage that POR is guaranteed.
7. If minimum  $V_{DD}$  is not reached before the internal POR reset is released,  $\overline{RST}$  must be driven low externally until minimum  $V_{DD}$  is reached.

### 19.7 Control Timing

Characteristic	Symbol	Min	Max	Unit
Internal Operating Frequency <sup>(2)</sup>	$f_{OP}$	—	6	MHz
$\overline{RST}$ Input Pulse Width Low <sup>(3)</sup>	$t_{IRL}$	50	—	ns

NOTES:

1.  $V_{DD} = 5.0 \text{ Vdc} \pm 10\%$ ,  $V_{SS} = 0 \text{ Vdc}$ ; timing shown with respect to 20%  $V_{DD}$  and 70%  $V_{DD}$ , unless otherwise noted.
2. Some modules may require a minimum frequency greater than dc for proper operation; see appropriate table for this information.
3. Minimum pulse width reset is guaranteed to be recognized. It is possible for a smaller pulse width to cause a reset.

### 19.8 Oscillator Characteristics

Characteristic	Symbol	Min	Typ	Max	Unit
Crystal Frequency <sup>(1)</sup>	$f_{OSCCLK}$	—	24	—	MHz
External Clock Reference Frequency <sup>(1), (2)</sup>	$f_{OSCCLK}$	dc	—	24	MHz
Crystal Load Capacitance <sup>(3)</sup>	$C_L$	—	15	—	pF
Crystal Fixed Capacitance <sup>(3)</sup>	$C_1$	—	$2 \times C_L$	—	
Crystal Tuning Capacitance <sup>(3)</sup>	$C_2$	—	$2 \times C_L$	—	
Feedback Bias Resistor	$R_B$	—	10	—	$M\Omega$
Series Resistor <sup>(3), (4)</sup>	$R_S$	—	—	—	

NOTES:

1. The sync processor module is designed to function at  $f_{OSCCLK} = 24\text{MHz}$ . The values given here are oscillator specifications.
2. No more than 10% duty cycle deviation from 50%
3. Consult crystal vendor data sheet
4. Not Required for high frequency crystals

19.9 ADC Characteristics

Characteristic <sup>(1)</sup>	Symbol	Min	Max	Unit	Comments
Supply voltage	V <sub>DDAD</sub>	4.5 (V <sub>DD</sub> min)	5.5 (V <sub>DD</sub> max)	V	
Input voltages	V <sub>ADIN</sub>	0	$\frac{2}{3} V_{DD}$	V	
Resolution	B <sub>AD</sub>	8	8	Bits	
Absolute accuracy (V <sub>SS</sub> = 0 V, V <sub>DD</sub> = 5 V ± 10%)	A <sub>AD</sub>	—	± 2	LSB	Includes quantization
ADC internal clock	f <sub>ADIC</sub>	0.375	6	MHz	t <sub>AIC</sub> = 1/f <sub>ADIC</sub> , tested only at 1.5 MHz
Conversion range	R <sub>AD</sub>	V <sub>SS</sub>	$\frac{2}{3} V_{DD}$	V	
Power-up time	t <sub>ADPU</sub>	16		t <sub>AIC</sub> cycles	
Conversion time	t <sub>ADC</sub>	12	13	t <sub>AIC</sub> cycles	
Sample time <sup>(2)</sup>	t <sub>ADS</sub>	4	—	t <sub>AIC</sub> cycles	
Zero input reading <sup>(3)</sup>	Z <sub>ADI</sub>	00	02	Hex	
Full-scale reading <sup>(3)</sup>	F <sub>ADI</sub>	FD	FF	Hex	
Input capacitance	C <sub>ADI</sub>	—	8	pF	Not tested
Input leakage <sup>(4)</sup> Port C	—	—	± 1	µA	

NOTES:

- V<sub>DD</sub> = 5.0 Vdc ± 10%, V<sub>SS</sub> = 0 Vdc, T<sub>A</sub> = T<sub>L</sub> to T<sub>H</sub>, unless otherwise noted.
- Source impedances greater than 10 kΩ adversely affect internal RC charging time during input sampling.
- Zero-input/full-scale reading requires sufficient decoupling measures for accurate conversions.
- The external system error caused by input leakage current is approximately equal to the product of R source and input current.

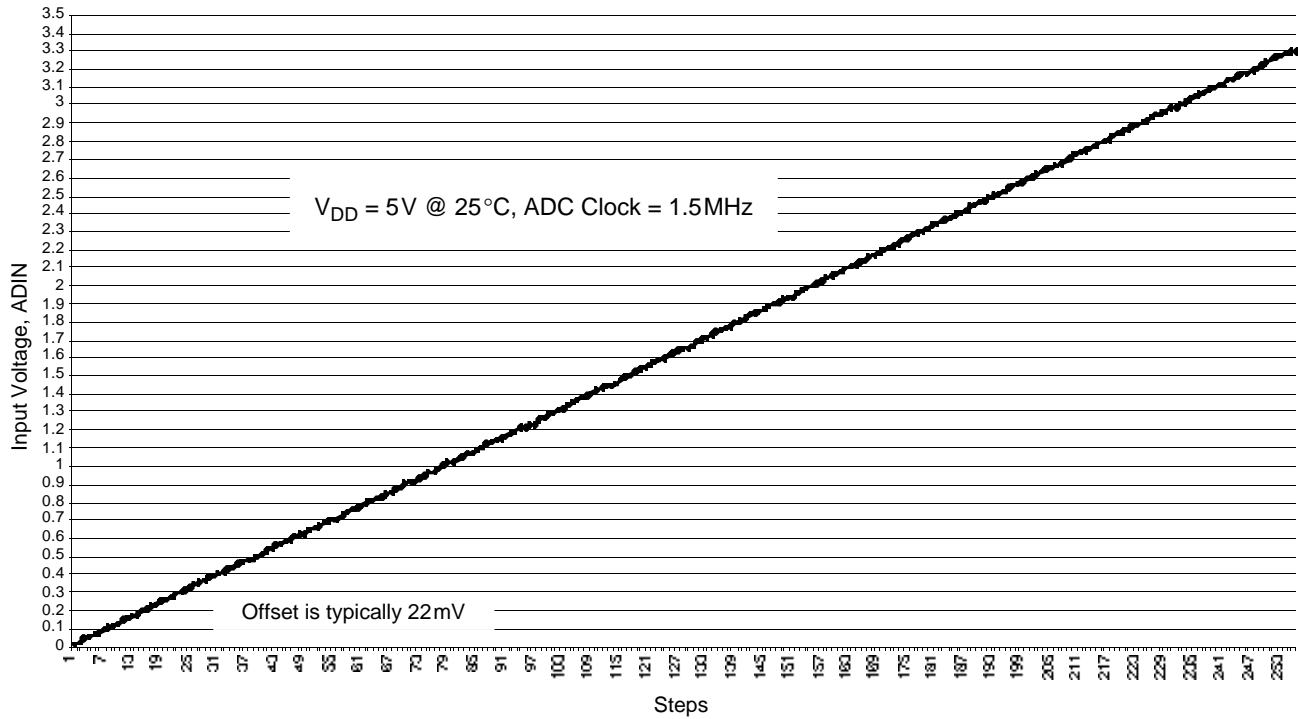

Figure 19-1. ADC Input Voltage vs. Step Readings

### 19.10 Timer Interface Module Characteristics

Characteristic	Symbol	Min	Max	Unit
Input Capture Pulse Width	$t_{TIH}, t_{TIL}$	125	—	ns
Input Clock Pulse Width	$t_{TCH}, t_{TCL}$	$(1/f_{OP}) + 5$	—	ns

### 19.11 Sync Processor Timing

Characteristic	Symbol	Min	Max	Unit
VSYNC input sync pulse	$t_{VI.SP}$	8	2048	$\mu s$
HSYNC input sync pulse	$t_{HI.SP}$	0.1	6	$\mu s$
VSYNC to VSYNCO delay (8pF loading)	$t_{Vd}$	30	40	$\mu s$
HSYNC to HSYNCO delay (8pF loading)	$t_{Hd}$	30	40	$\mu s$

NOTES:

1.  $V_{DD} = 5.0 Vdc \pm 10\%$ ,  $V_{SS} = 0 Vdc$ ; timing shown with respect to 20%  $V_{DD}$  and 70%  $V_{DD}$ , unless otherwise noted.

19.12 DDC12AB Timing

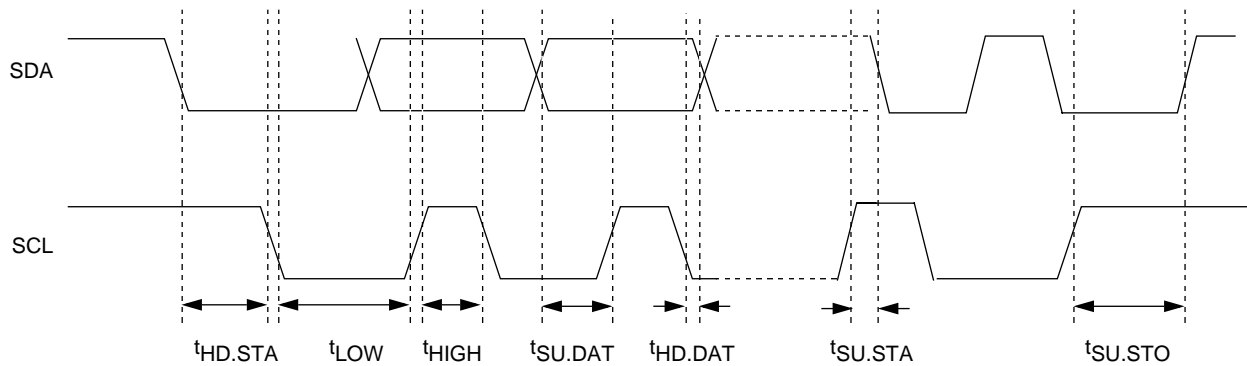

19.12.1 DDC12AB Interface Input Signal Timing

Characteristic	Symbol	Min	Max	Unit
START condition hold time	$t_{HD.STA}$	2	—	$t_{CYC}$
Clock low period	$t_{LOW}$	4	—	$t_{CYC}$
Clock high period	$t_{HIGH}$	4	—	$t_{CYC}$
Data set-up time	$t_{SU.DAT}$	250	—	ns
Data hold time	$t_{HD.DAT}$	0	—	ns
START condition set-up time (for repeated START condition only)	$t_{SU.STA}$	2	—	$t_{CYC}$
STOP condition set-up time	$t_{SU.STO}$	2	—	$t_{CYC}$

NOTES:

1.  $V_{DD} = 5.0 \text{ Vdc} \pm 10\%$ ,  $V_{SS} = 0 \text{ Vdc}$ ; timing shown with respect to 20%  $V_{DD}$  and 70%  $V_{DD}$ , unless otherwise noted.

19.12.2 DDC12AB Interface Output Signal Timing

Characteristic	Symbol	Min	Max	Unit
SDA/SCL rise time <sup>(2)</sup>	$t_R$	—	1	$\mu\text{s}$
SDA/SCL fall time	$t_F$	—	300	ns
Data set-up time	$t_{SU.DAT}$	$t_{LOW}$	—	ns
Data hold time	$t_{HD.DAT}$	0	—	ns

NOTES:

1.  $V_{DD} = 5.0 \text{ Vdc} \pm 10\%$ ,  $V_{SS} = 0 \text{ Vdc}$ ; timing shown with respect to 20%  $V_{DD}$  and 70%  $V_{DD}$ , unless otherwise noted.

2. With 200pF loading on the SDA/SCL pins.

## Section 20. Mechanical Specifications

### 20.1 Contents

20.2	Introduction . . . . .	239
20.3	44-Pin Plastic Quad Flat Pack (QFP) . . . . .	240
20.4	42-Pin Shrink Dual in-Line Package (SDIP) . . . . .	241

### 20.2 Introduction

This section gives the dimensions for:

- 44-pin plastic quad flat pack (case 824E-02)
- 42-pin shrink dual in-line package (case 858-01)

The following figures show the latest package drawings at the time of this publication. To make sure that you have the latest package specifications, contact one of the following:

- Local Motorola Sales Office
- World Wide Web at <http://www.motorola.com/semiconductors/>

Follow the World Wide Web on-line instructions to retrieve the current mechanical specifications.

Mechanical Specifications

20.3 44-Pin Plastic Quad Flat Pack (QFP)

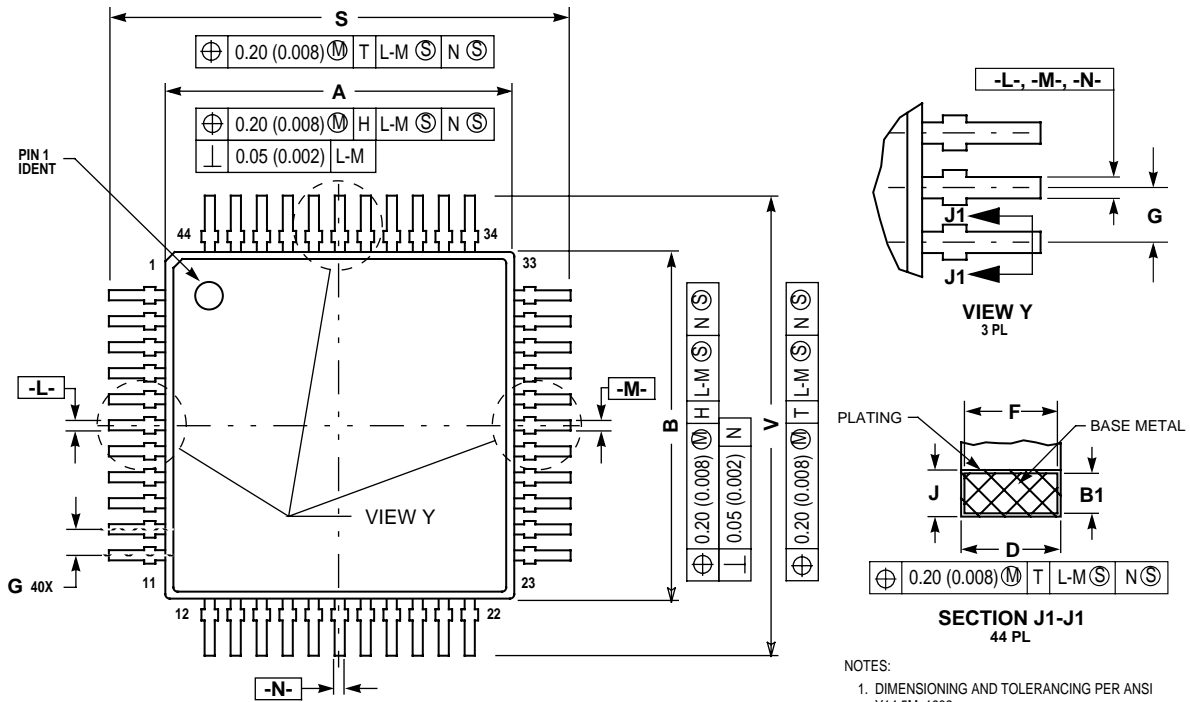

- NOTES:
- DIMENSIONING AND TOLERANCING PER ANSI Y14.5M, 1982.
  - CONTROLLING DIMENSION: MILLIMETER.
  - DATUM PLANE -H- IS LOCATED AT BOTTOM OF LEAD AND IS COINCIDENT WITH THE LEAD WHERE THE LEAD EXITS THE PLASTIC BODY AT THE BOTTOM OF THE PARTING LINE.
  - DATUMS -L-, -M- AND -N- TO BE DETERMINED AT DATUM PLANE -H-.
  - DIMENSIONS S AND V TO BE DETERMINED AT SEATING PLANE -T-.
  - DIMENSIONS A AND B DO NOT INCLUDE MOLD PROTRUSION. ALLOWABLE PROTRUSION IS 0.25 (0.010) PER SIDE. DIMENSIONS A AND B DO INCLUDE MOLD MISMATCH AND ARE DETERMINED AT DATUM PLANE -H-.
  - DIMENSION D DOES NOT INCLUDE DAMBAR PROTRUSION. DAMBAR PROTRUSION SHALL NOT CAUSE THE D DIMENSION TO EXCEED 0.530 (0.021).

DIM	MILLIMETERS		INCHES	
	MIN	MAX	MIN	MAX
A	9.90	10.10	0.390	0.398
B	9.90	10.10	0.390	0.398
C	2.00	2.21	0.079	0.087
D	0.30	0.45	0.0118	0.0177
E	2.00	2.10	0.079	0.083
F	0.30	0.40	0.012	0.016
G	0.80 BSC		0.031 BSC	
J	0.13	0.23	0.005	0.009
K	0.65	0.95	0.026	0.037
M	5°	10°	5°	10°
S	12.95	13.45	0.510	0.530
V	12.95	13.45	0.510	0.530
W	0.000	0.210	0.000	0.008
Y	5°	10°	5°	10°
A1	0.450 REF		0.018 REF	
B1	0.130	0.170	0.005	0.007
C1	1.600 REF		0.063 REF	
R1	0.130	0.300	0.005	0.012
R2	0.130	0.300	0.005	0.012
q1	5°	10°	5°	10°
q2	0°	7°	0°	7°

Figure 20-1. 44-Pin QFP (Case 824E)



20.4 42-Pin Shrink Dual in-Line Package (SDIP)

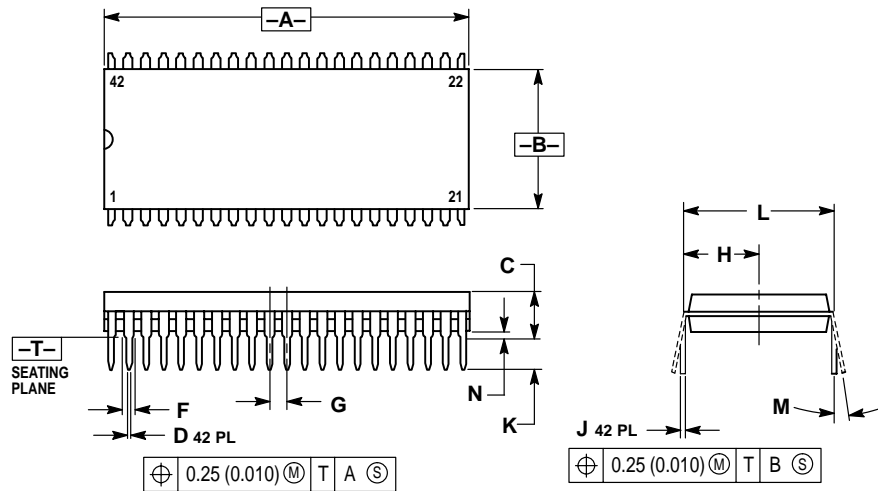

- NOTES:
1. DIMENSIONING AND TOLERANCING PER ANSI Y14.5M, 1982.
  2. CONTROLLING DIMENSION: INCH.
  3. DIMENSION L TO CENTER OF LEAD WHEN FORMED PARALLEL.
  4. DIMENSIONS A AND B DO NOT INCLUDE MOLD FLASH. MAXIMUM MOLD FLASH 0.25 (0.010).

DIM	INCHES		MILLIMETERS	
	MIN	MAX	MIN	MAX
A	1.435	1.465	36.45	37.21
B	0.540	0.560	13.72	14.22
C	0.155	0.200	3.94	5.08
D	0.014	0.022	0.36	0.56
F	0.032	0.046	0.81	1.17
G	0.070 BSC		1.778 BSC	
H	0.300 BSC		7.62 BSC	
J	0.008	0.015	0.20	0.38
K	0.115	0.135	2.92	3.43
L	0.600 BSC		15.24 BSC	
M	0° - 15°		0° - 15°	
N	0.020	0.040	0.51	1.02

Figure 20-2. 42-Pin SDIP (Case 858)





# Freescale Semiconductor, Inc.

Freescale Semiconductor, Inc.

Motorola reserves the right to make changes without further notice to any products herein. Motorola makes no warranty, representation or guarantee regarding the suitability of its products for any particular purpose, nor does Motorola assume any liability arising out of the application or use of any product or circuit, and specifically disclaims any and all liability, including without limitation consequential or incidental damages. "Typical" parameters which may be provided in Motorola data sheets and/or specifications can and do vary in different applications and actual performance may vary over time. All operating parameters, including "Typicals" must be validated for each customer application by customer's technical experts. Motorola does not convey any license under its patent rights nor the rights of others. Motorola products are not designed, intended, or authorized for use as components in systems intended for surgical implant into the body, or other applications intended to support or sustain life, or for any other application in which the failure of the Motorola product could create a situation where personal injury or death may occur. Should Buyer purchase or use Motorola products for any such unintended or unauthorized application, Buyer shall indemnify and hold Motorola and its officers, employees, subsidiaries, affiliates, and distributors harmless against all claims, costs, damages, and expenses, and reasonable attorney fees arising out of, directly or indirectly, any claim of personal injury or death associated with such unintended or unauthorized use, even if such claim alleges that Motorola was negligent regarding the design or manufacture of the part. Motorola and  are registered trademarks of Motorola, Inc. Motorola, Inc. is an Equal Opportunity/Affirmative Action Employer.

#### How to reach us:

**USA/EUROPE/Locations Not Listed:** Motorola Literature Distribution; P.O. Box 5405, Denver, Colorado 80217. 1-303-675-2140 or 1-800-441-2447

**JAPAN:** Motorola Japan Ltd.; SPS, Technical Information Center, 3-20-1, Minami-Azabu, Minato-ku, Tokyo 106-8573 Japan. 81-3-3440-3569

**ASIA/PACIFIC:** Motorola Semiconductors H.K. Ltd.; Silicon Harbour Center, 2 Dai King Street, Tai Po Industrial Estate, Tai Po, N.T., Hong Kong. 852-26668334

**Technical Information Center: 1-800-521-6274**

**HOME PAGE:** <http://www.motorola.com/semiconductors/>

© Motorola, Inc., 2000



**MOTOROLA**

**For More Information On This Product,  
Go to: [www.freescale.com](http://www.freescale.com)**