

# M/A-COM Surface Mount Monolithic PIN Diode Chip

## Features

- Surface Mount Diode
- No Wirebonds Required
- Rugged Silicon-Glass Construction
- Silicon Nitride Passivation
- Polymer Scratch Protection
- Low Parasitic Capacitance and Inductance
- High Power Handling (Efficient Heatsinking)

## Description

M/A-COM's MA4SPS402 is a silicon-glass PIN diode fabricated with M/A-COM's patented HMIC™ process. This device features two silicon pedestals embedded in a low loss glass. The diode is formed on the top of one pedestal and connections to the backside of the device are facilitated by making the pedestal side walls conductive. Selective backside metalization is applied producing a surface mount device. The topside is fully encapsulated with silicon nitride and has an additional polymer layer for scratch protection. These protective coatings prevent damage to the junction and the anode air-bridge during handling and assembly.

## Applications

These devices can be used in series and shunt switches up to 20 GHz where smaller area and profile are required. Low parasitic values of L and C make additional circuit tuning unnecessary. These diodes can also be used for switched pad attenuator circuits.

## Absolute Maximum Ratings<sup>1</sup>

@ T<sub>A</sub> = +25°C (unless otherwise specified)

Parameter	Absolute Maximum
Reverse Voltage	-70 V
Forward Current	100 mA
Operating Temperature	-65°C to +150°C
Storage Temperature	-65°C to +150°C
Mounting Temperature	+235°C for 10 seconds

1. Exceeding these limits may cause permanent damage.

## Case Style

ODS-1253<sup>1, 2</sup>

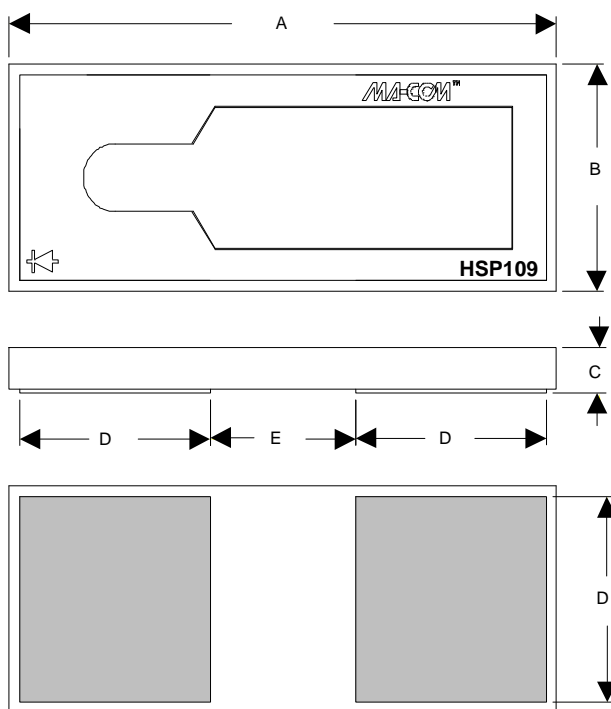

1. Backside metal: 0.1 micron thk. gold.
2. Hatched areas indicate bond pads.

DIM.	INCHES		MILLIMETERS	
	MIN.	MAX.	MIN.	MAX.
A	0.0465	0.0528	1.180	1.340
B	0.0173	0.0236	0.440	0.600
C	0.0040	0.0080	0.102	0.203
D	0.0150	0.0170	0.381	0.432
E	0.0140	0.0160	0.355	0.406

Specifications subject to change without notice.

- North America: Tel. (800) 366-2266, Fax (800) 618-8883
- Asia/Pacific: Tel.+81-44-844-8296, Fax +81-44-844-8298
- Europe: Tel. +44 (1344) 869 595, Fax+44 (1344) 300 020

Visit [www.macom.com](http://www.macom.com) for additional data sheets and product information.

**Electrical Specifications @ +25°C**

Symbol	Test Conditions	Units	Min.	Typ.	Max.
C <sub>T</sub>	-40 Volts, 1 MHz <sup>1</sup>	pF		0.034	0.045
C <sub>T</sub>	-40 Volts, 1 GHz <sup>1,3</sup>	pF		0.041	
R <sub>S</sub>	10 mA, 2 MHz <sup>2</sup>	Ω		5.0	
R <sub>S</sub>	10 mA, 100 MHz <sup>2</sup>	Ω		4.6	
R <sub>S</sub>	10 mA, 1 GHz <sup>2,3</sup>	Ω		5.0	
V <sub>F</sub>	1.0 mA	V		0.84	1.00
V <sub>R</sub>	10 μA	V	-70	-120	
I <sub>R</sub>	-70V	μA			10
T <sub>L</sub>	10 mA / 6 mA	ns		200	

1. Total capacitance is equivalent to the sum of junction capacitance C<sub>j</sub> and parasitic capacitance.
2. Series resistance R<sub>S</sub> is equivalent to the total diode series resistance including the junction resistance R<sub>j</sub>.
3. R<sub>S</sub> and C<sub>p</sub> is measured on an HP4291A with die mounted in an ODS-186 package with conductive silver epoxy.

**Handling Procedures**

All semiconductor chips should be handled with care to avoid damage or contamination from perspiration and skin oils. The use of plastic tipped tweezers or vacuum pickups is strongly recommended for individual components. Bulk handling should insure that abrasion and mechanical shock are minimized.

**ESD**

These devices very susceptible to ESD and are rated Class 0 (0-199V) per HBM MIL-STD-883, method 3015.7 [C = 100pF ±10%, R = 1.5kΩ ±1%]. Even though tested die pass 100V ESD, they must be handled in a static-free environment.

**Bonding Techniques**

Attachment to a circuit board is made simple through the use of surface mount technology. Mounting pads are conveniently located on the bottom surface of these diodes and are removed from the active junction locations. These diodes are well suited for solder attachment onto hard and soft substrates. The use of 80/20 Au/Sn and 60/40 Sn/Pb solder is recommended. Conductive epoxy paste for attachment may also be used, this can be silk-screened, or used with a conductive sheet apoxy.

When soldering these diodes to a hard substrate, hot gas die bonding is preferred. We recommend utilizing a vacuum tip and a force of 60 to 100 grams applied normal to the top surface of the part. When soldering to soft substrates, it is recommended to use a lead-tin interface at the circuit board mounting pads. Position the die so that its mounting pads are aligned with the circuit board's mounting pads Reflow the solder by heating the circuit trace near the mounting pad while applying 60 to 100 grams of force perpendicular to the top surface of the die.

Since the HMIC<sup>™</sup> glass is transparent, the edges of the mounting pads closest to each other can be visually inspected through the die after attach is completed.

**Functional Schematic<sup>1</sup>**

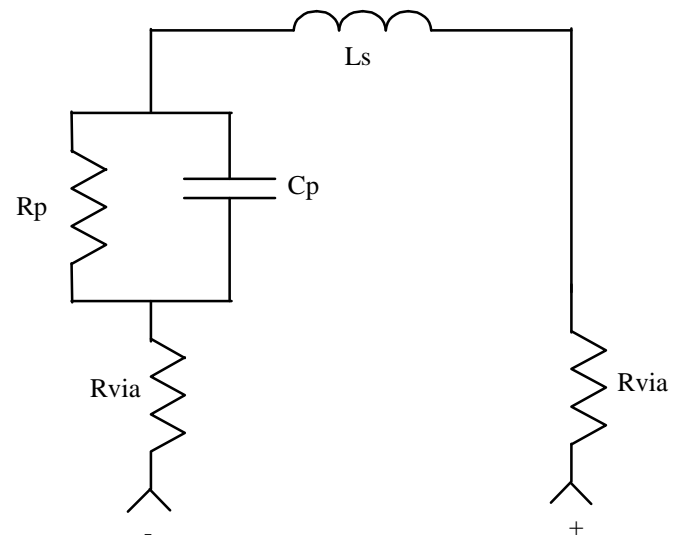

1.  $R_s = 2 * R_{via} + R_p$

Specifications subject to change without notice.

Typical Performance Curves @ +25°C

Typical Total Resistance  $R_S$  vs. Forward Current and Frequency

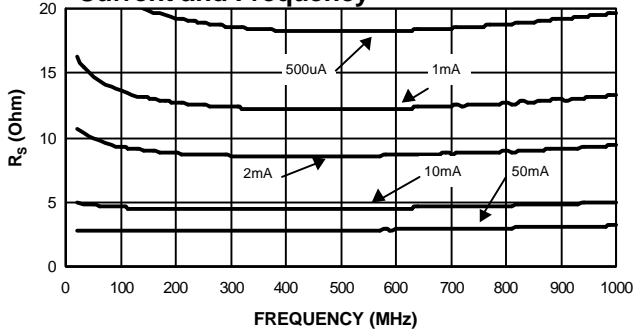

Typical Total Capacitance  $C_P$  vs. Reverse Voltage and Frequency

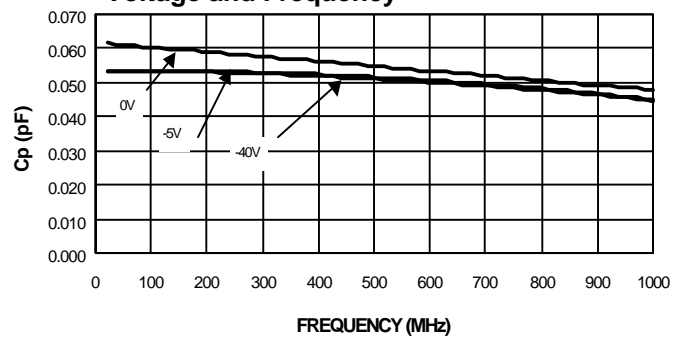

$C_p$  vs.  $V$  @ 100 MHz and 1 GHz

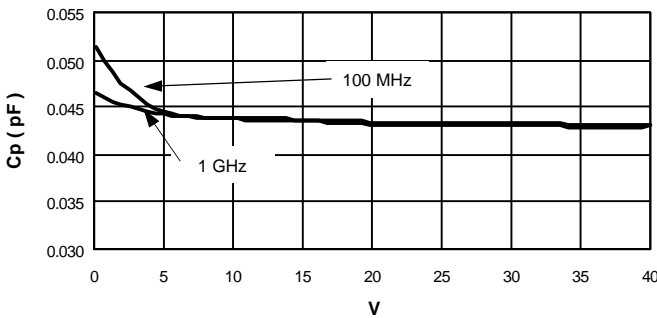

$R_p$  vs.  $V$  @ 100 MHz and 1 GHz

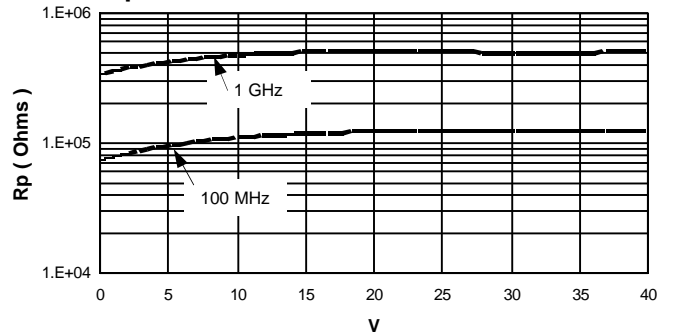

$R_s$  vs.  $I$  @ 100 MHz and 1 GHz

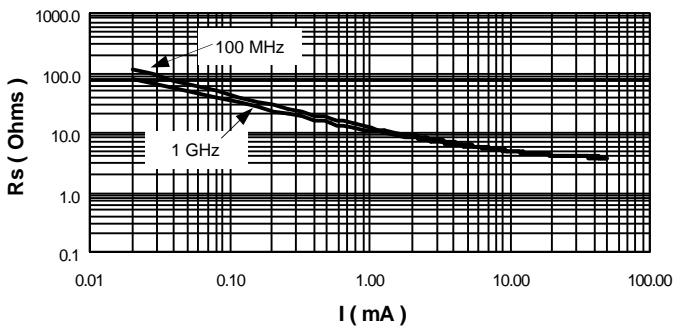

$L_s$  vs. Frequency @ 10 mA

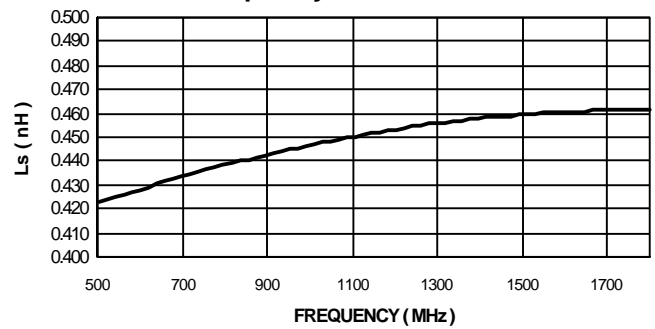

Specifications subject to change without notice.

V 2.0

■ North America: Tel. (800) 366-2266, Fax (800) 618-8883  
 ■ Asia/Pacific: Tel.+81-44-844-8296, Fax +81-44-844-8298  
 ■ Europe: Tel. +44 (1344) 869 595, Fax+44 (1344) 300 020

Visit [www.macom.com](http://www.macom.com) for additional data sheets and product information.