

4-BIT SINGLE CHIP MICROCOMPUTERS

# **GMS36/37XXX(T)**

## **SERIES USER`S MANUAL**

- **GMS36/37004(T)**
- **GMS36/37112(T)**
- **GMS36/37140(T)**

---

**Revision 1.0**

**Published by**  
**MCU Application Team in HYUNDAI ELECTRONICS INDUSTRIES Co., Ltd.**

**© HYUNDAI ELECTRONICS INDUSTRIES Co., Ltd. 2000 All Right Reserved.**

**Editor's E-Mail :**   **lbkd@hei.co.kr**  
                          **kanghan@hei.co.kr**  
                          **rhja@hei.co.kr**

---

Additional information of this manual may be served by Hyundai Electronics Industries Offices in Korea or Distributors and Representative listed at address directory.

Hyundai Electronics Industries reserves the right to make changes to any Information here at any time without notice.

The information, diagrams, and other data in this manual are correct and reliable; however, Hyundai Electronics Industries Co., Ltd. is in no way responsible for any violations of patents or other rights of the third party generated by the use of this manual.

## Table of Contents

### Chapter 1 GMS36XXX

Description	1-1
Features	1-1
Block diagram	1-2
Pin assignment	1-3
Pin description	1-4
Pin circuit	1-5
Port operation	1-7
Optional features	1-7
Electrical characteristics	1-8

### Chapter 2 GMS37XXX

Description	2-1
Features	2-1
Block diagram	2-2
Pin assignment	2-3
Pin description	2-4
Pin circuit	2-5
Port operation	2-7
Optional features	2-7
Electrical characteristics	2-8

### Chapter 3 PACKAGE DIMENSIONS

### Chapter 4 FUNCTIONAL DESCRIPTION

Program memory (ROM)	4-1
ROM address register	4-2
Data memory (RAM)	4-3
X-register (X)	4-3
Y-register (Y)	4-4
Accumulator (Acc)	4-4
Arithmetic and Logic Unit (ALU)	4-4
State Counter (SC)	4-5
Clock generator	4-6
Pulse generator	4-7
Reset operation	4-8
Watch Dog Timer (WDT)	4-10
Stop operation	4-11

---

## Table of Contents

---

### Chapter 5 INSTRUCTION

Instruction format	.....5-1
Instruction table	.....5-2
Details of instruction system	.....5-4

### Chapter 6 APPLICATION

Guideline for S/W	.....6-1
GMS36112 Circuit diagram	.....6-2
GMS37112 Circuit diagram	.....6-3
Truth Table for example program	.....6-4
Output waveform of uPD6121G	.....6-5
Example program-uPD6121G	.....6-6
Reference to GMS36XXXT B/D	.....6-12
Reference to GMS37XXXT B/D	.....6-13

### Chapter 7 GMS36XXXT

Description	.....7-1
Features	.....7-1
Pin description	.....7-2
Stop operation	.....7-3
Electrical characteristics	.....7-4

### Chapter 8 GMS37XXXT

Description	.....8-1
Features	.....8-1
Pin description	.....8-2
Stop operation	.....8-3
Electrical characteristics	.....8-4

### Chapter 9 EPROM

Mode define	.....9-1
Port define for GMS36XXXT	.....9-1
Port define for GMS37XXXT	.....9-2
AC/DC timing requirements for program / read mode	.....9-3
Program / verify timing diagrams in kHz version	.....9-4
Program / verify timing diagrams in MHz version	.....9-8
Caution when programming	.....9-14

---

---

<b>GMS36XXX</b>	<b>1</b>	
<b>GMS37XXX</b>	<b>2</b>	
<b>PACKAGE DIMENSIONS</b>	<b>3</b>	
<b>FUNCTIONAL DESCRIPTION</b>	<b>4</b>	
<b>INSTRUCTION</b>	<b>5</b>	
<b>APPLICATION</b>	<b>6</b>	
<b>GMS36XXXT</b>	<b>7</b>	
<b>GMS37XXXT</b>	<b>8</b>	
<b>EPROM</b>	<b>9</b>	

---

## 1. GMS36XXX

### Description

The GMS36XXX series are remote control transmitter which uses CMOS technology. This enables transmission code outputs of different configurations, multiple custom code output, and double push key output for easy fabrication. The GMS36XXX series are suitable for remote control of TV, VCR, FANS, Air-conditioners, Audio Equipment, Toys, Games etc.

### Features

- Program memory : 1,024 bytes for GMS36004/112/140
- Data memory :  $32 \times 4$  bits
- 43 types of instruction set
- 3 levels of subroutine nesting
- Operating frequency : 300kHz ~ 1MHz at kHz version  
2.4MHz ~ 4MHz at MHz version
- Instruction cycle :  $f_{OSC}/6$  at kHz version  
 $f_{OSC}/48$  at MHz version
- CMOS process (Single 3.0V power supply)
- Stop mode (Through internal instruction)
- Released stop mode by key input (Masked option)
- Built in Power-on Reset circuit
- Built in Low Voltage Detection circuit
- Built in capacitor for ceramic oscillation circuit at kHz version
- Built in a watch dog timer (WDT)
- Built in transistor for I.R LED Drive :  $I_{OL} = 210\text{mA}$  at  $V_{DD} = 3\text{V}$  and  $V_O = 0.3\text{V}$
- Low operating voltage: 2.0 ~ 3.6V (at 300kHz ~ 4MHz)

Table 1-1 GMS36XXX series members

Series	GMS36004	GMS36112	GMS36140
Program memory	1,024	1,024	1,024
Data memory	$32 \times 4$	$32 \times 4$	$32 \times 4$
I/O ports	-	4	4
Input ports	4	4	4
Output ports	6 (D0~D5)	6 (D0~D5)	10 (D0~D9)
Package	16DIP/SOP	20DIP/SOP/SSOP	24Skinny DIP/SOP

Block Diagram

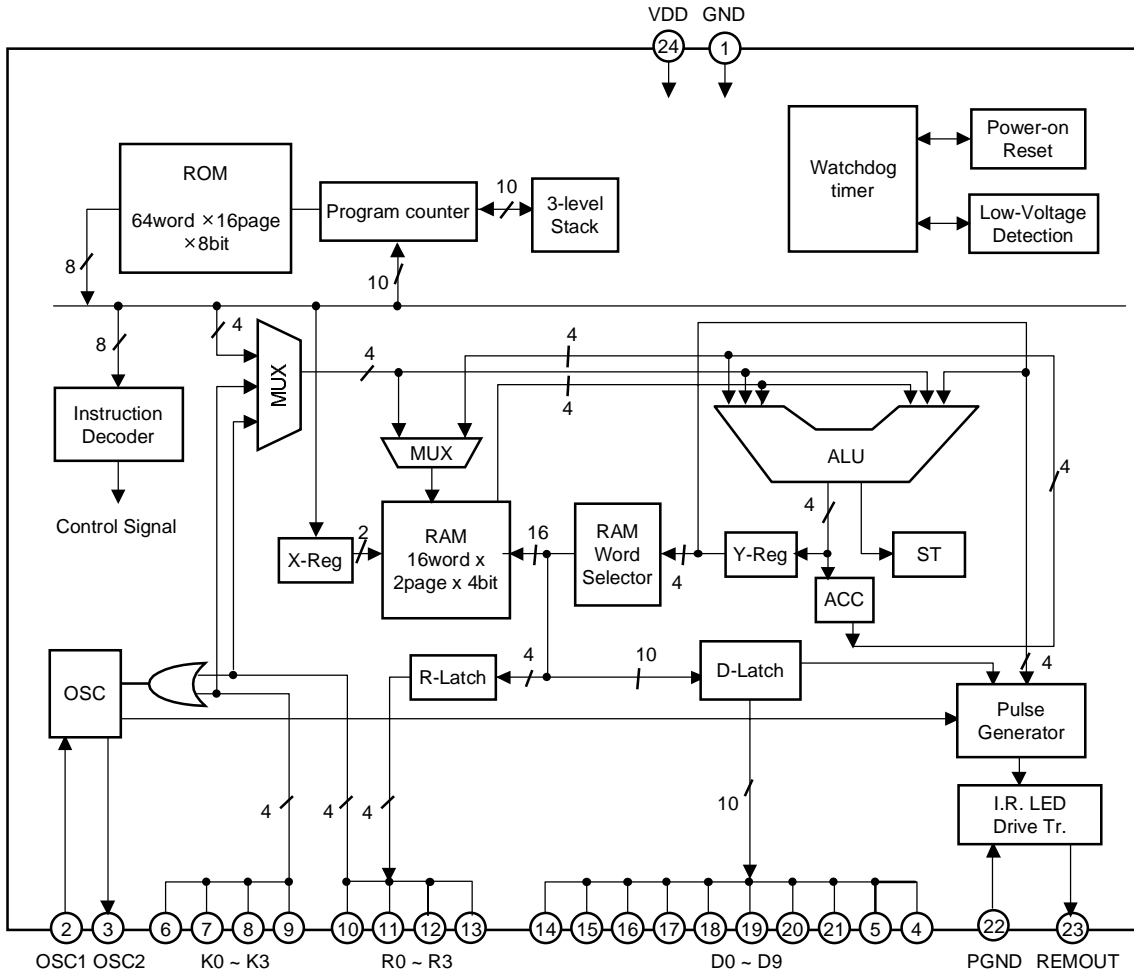

Fig 1-1 Block Diagram (In case of GMS36140)

Pin Assignment

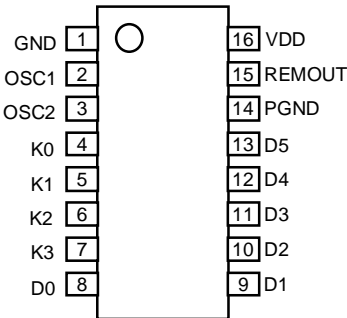

Fig 1-2 GMS36004 Pin Assignment (16DIP/SOP)

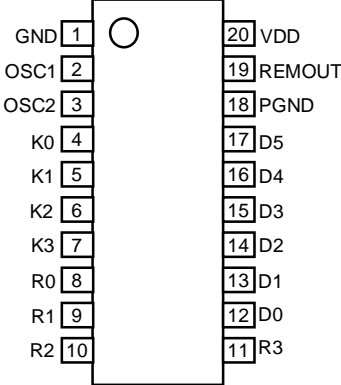

Fig 1-3 GMS36112 Pin Assignment (20DIP/SOP/SSOP)

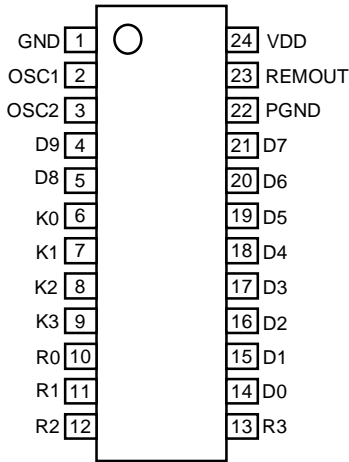

Fig 1-4 GMS36140 Pin Assignment (24Skinny-DIP/SOP)



## Pin Description

<b>Pin</b>	<b>I/O</b>	<b>Function</b>
VDD	-	Connected to 2.0~ 3.6V power supply
GND	-	Connected to 0V power supply.
K0 ~ K3	Input	4-bit input port with built in pull-up resistor. STOP mode is released by "L" input of each pin.(masked option)
D0 ~ D9	Output	Each can be set and reset independently. The output is the structure of N-channel-open-drain.
R0 ~ R3	I/O	4-bit I/O port. (Input mode is set only when each of them output "H".) In outputting, each can be set and reset independently(or at once.) The output is in the form of C-MOS. Pull-up resistor and STOP release mode can be respectively selected as masked option for each pin. (It is released by "L" input at STOP.)
OSC1	Input	Oscillator input. Input to the oscillator circuit and connection point for ceramic resonator. Internal capacitors available at kHz version. A feedback resistor is internally connected between this pin and OSC2.
OSC2	Output	Connect a resonator between this pin and OSC1.
REMOUT	Output	High current output port driving I.R. LED. The output is in the form of N-channel-open-drain.
PGND	-	High current Tr. ground pin. (connected to GND) High current output Tr. is connected between this pin and REMOUT.

Pin Circuit

Pin	I/O	I/O circuit	Note
R0 ~ R3	I/O		<ul style="list-style-type: none"> <li>- CMOS output.</li> <li>- "H" output at reset.</li> </ul> (Option) <ul style="list-style-type: none"> <li>- Built in MOS Tr for pull-up, about 140kΩ.</li> </ul>
K0 ~ K3	I		<ul style="list-style-type: none"> <li>- Built in MOS Tr for pull-up, about 140kΩ.</li> </ul>
D0 ~ D9	O		<ul style="list-style-type: none"> <li>- Open drain output.</li> <li>- "L" output at reset.</li> </ul>
REMOUT	O		<ul style="list-style-type: none"> <li>- Open drain output.</li> <li>- Output Tr. disable at reset.</li> </ul>
PGND	-		

Pin	I/O	I/O circuit	Note
OSC2	O		<ul style="list-style-type: none"> <li>- Built in feedback-resistor about <math>1\text{M}\Omega</math></li> <li>- Built in damping-resistor [No resistor in MHz operation]</li> </ul>
OSC1	I		<p>(Option)</p> <ul style="list-style-type: none"> <li>- Built in resonance capacitor at kHz version</li> <li>- <math>C1=C2 = 100\text{pF} \pm 15\%</math> [C1,C2 are not available for MHz version]</li> </ul>

## Port Operation

Value of X-reg	Value of Y-reg	Operation
0 or 1	0 ~ 7	SO : D(Y) ← 1 (High-Z) RO : D(Y) ← 0
0 or 1	8	REMOUT port repeats "L" and "H" in pulse frequency. (when PMR = 5, it is fixed at "L") SO : REMOUT (PMR) ← 0 RO : REMOUT (PMR) ← 1 (High-Z)
0 or 1	9	SO : D0 ~ D9 ← 1 (High-Z) RO : D0 ~ D9 ← 0
0 or 1	A ~ D	SO : R(Y-Ah) ← 1 RO : R(Y-Ah) ← 0
0 or 1	E	SO : R0 ~ R3 ← 1 RO : R0 ~ R3 ← 0
0 or 1	F	SO : D0 ~ D9 ← 1 (High-Z), R0 ~ R3 ← 1 RO : D0 ~ D9 ← 0, R0 ~ R3 ← 0
2 or 3	0	SO : D(8) ← 1 (High-Z) RO : D(8) ← 0
2 or 3	1	SO : D(9) ← 1 (High-Z) RO : D(9) ← 0

## Optional Features

The GMS36XXX series offer the following optional features.

These options are masked.

- I/O terminals having pull-up resistor : R0 ~ R3
- Input terminals having STOP release mode : K0 ~ K3, R0 ~ R3.
- Output form at STOP mode

D0 ~ D9 : "L" or keep before stop mode.

These options are offered default.

- Ceramic oscillation circuit contained (or not contained)  
[ This option is not available for MHz Ceramic oscillator. ]
- Instruction cycle selection :

$T = 48 / f_{OSC}$  or  $6 / f_{OSC}$

Electrical Characteristics

Absolute maximum ratings (Ta = 25 °C)

Parameter	Symbol	Max. rating	Unit
Supply Voltage	V <sub>DD</sub>	-0.3 ~ 5.0	V
Power dissipation	P <sub>D</sub>	700 *	mW
Storage temperature range	Tstg	-55 ~ 125	°C
Input voltage	V <sub>IN</sub>	-0.3 ~ V <sub>DD</sub> +0.3	V
Output voltage	V <sub>OUT</sub>	-0.3 ~ V <sub>DD</sub> +0.3	V

\* Thermal derating above 25 °C : 6mW per degree °C rise in temperature.

Recommended operating condition

Parameter	Symbol	Condition	Rating	Unit
Supply Voltage	V <sub>DD</sub>	300KHz ~ 4MHz	2.0 ~ 3.6	V
Operating temperature	Topr	-	-20 ~ +70	°C

Electrical characteristics (Ta=25 °C, V<sub>DD</sub>= 3V)

Parameter	Symbol	Limits			Unit	Condition	
		Min.	Typ.	Max.			
Input H current	I <sub>IH</sub>	-	-	1	uA	V <sub>i</sub> = V <sub>DD</sub> , R having no Pull-up	
Input L current	I <sub>IL</sub>	-1	-	-	uA	V <sub>i</sub> = GND, R having no Pull-up	
K Pull-up Resistance	R <sub>PU1</sub>	70	140	300	kΩ	V <sub>i</sub> = GND	
R Pull-up Resistance	R <sub>PU2</sub>	70	140	300	kΩ	V <sub>i</sub> = GND, Output off	
Feedback Resistance	R <sub>FD</sub>	0.3	1.0	3.0	MΩ	V <sub>OSC1</sub> = GND, V <sub>OSC2</sub> = GND	
K, R Input H voltage	V <sub>IH1</sub>	2.1	-	-	V	-	
K, R Input L voltage	V <sub>IL1</sub>	-	-	0.9	V	-	
D, R Output L voltage	V <sub>OL2</sub> <sup>*1</sup>	-	0.15	0.4	V	I <sub>OL2</sub> = 3mA	
OSC2 Output L voltage	V <sub>OL3</sub>	-	0.4	0.9	V	I <sub>OL3</sub> = 40uA (kHz) , 150uA(MHz)	
OSC2 Output H voltage	V <sub>OH3</sub>	2.1	2.5	-	V	I <sub>OH3</sub> = -40uA (kHz) , -150uA(MHz)	
REMOUT Output L current	I <sub>OL1</sub> <sup>*2</sup>	170	210	250	mA	V <sub>OL1</sub> = 0.3V	
REMOUT leakage current	I <sub>OLK1</sub>	-	-	1	uA	V <sub>OUT</sub> = V <sub>DD</sub> , Output off	
D, R Output leakage current	I <sub>OLK2</sub>	-	-	1	uA	V <sub>OUT</sub> = V <sub>DD</sub> , Output off	
Current on STOP mode	I <sub>STP</sub>	-	-	1	uA	At STOP mode	
Operating Supply current 1	I <sub>DD1</sub> <sup>*3</sup>	-	0.2	1.0	mA	f <sub>OSC</sub> = 455kHz	
Operating Supply current 2	I <sub>DD2</sub> <sup>*3</sup>	-	0.5	1.5	mA	f <sub>OSC</sub> = 4MHz	
System colck frequency	f <sub>OSC</sub> /6	f <sub>OSC</sub>	300	-	1000	kHz	kHz Version
	f <sub>OSC</sub> /48	f <sub>OSC</sub>	2.4	-	4	MHz	MHz Version.

\*1 Refer to < Fig.1-5 I<sub>OL2</sub> vs. V<sub>OL2</sub> Graph >

\*2 Refer to < Fig.1-6 I<sub>OL1</sub> vs. V<sub>OL1</sub> Graph >

\*3 I<sub>DD1</sub>, I<sub>DD2</sub>, is measured at RESET mode.

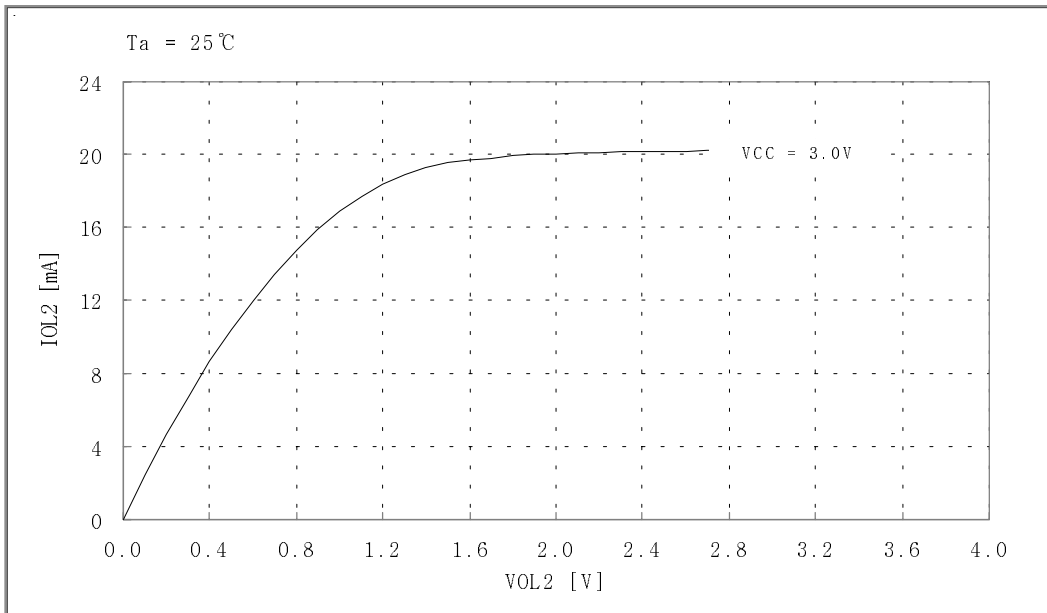

Fig 1-5.  $I_{OL2}$  vs.  $V_{OL2}$  Graph. ( D, R Port )

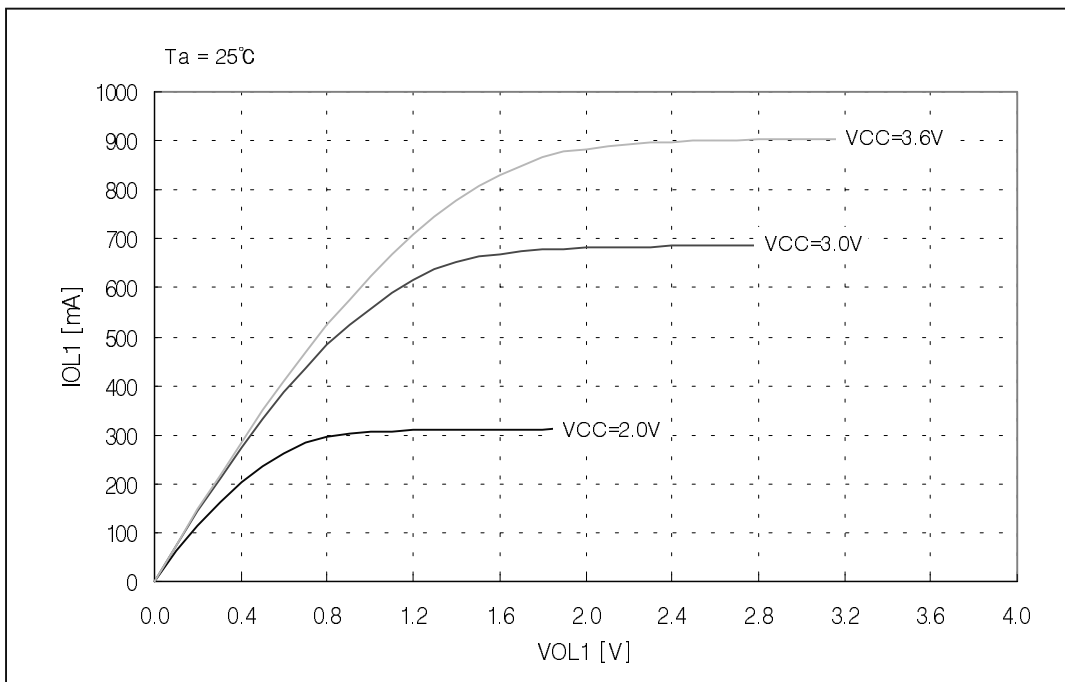

Fig 1-6.  $I_{OL1}$  vs.  $V_{OL1}$  Graph. ( REMOUT port )

---

<b>GMS36XXX</b>	<b>1</b>
<b>GMS37XXX</b>	<b>2</b>
<b>PACKAGE DIMENSIONS</b>	<b>3</b>
<b>FUNCTIONAL DESCRIPTION</b>	<b>4</b>
<b>INSTRUCTION</b>	<b>5</b>
<b>APPLICATION</b>	<b>6</b>
<b>GMS36XXXT</b>	<b>7</b>
<b>GMS37XXXT</b>	<b>8</b>
<b>EPROM</b>	<b>9</b>

---



## 2. GMS37XXX

### Description

The GMS37XXX series are remote control transmitter which uses CMOS technology. This enables transmission code outputs of different configurations, multiple custom code output, and double push key output for easy fabrication.

The GMS37XXX series are suitable for remote control of TV, VCR, FANS, Air-conditioners, Audio Equipment, Toys, Games etc.

It is possible to structure the 8 x 7 key matrix for GMS37112, and the 4 x 7 key matrix for GMS37004.

### Features

- Program memory : 1,024 bytes for GMS37004/112/140
- Data memory : 32 × 4 bits
- 43 types of instruction set
- 3 levels of subroutine nesting
- Operating frequency : 300kHz ~ 1MHz at kHz version  
2.4MHz ~ 4MHz at MHz version
- Instruction cycle :  $f_{OSC}/6$  at kHz version  
 $f_{OSC}/48$  at MHz version
- CMOS process (Single 3.0V power supply)
- Stop mode (Through internal instruction)
- Released stop mode by key input (Masked option)
- Built in Power-on Reset circuit
- Built in Low Voltage Detection circuit
- Built in capacitor for ceramic oscillation circuit at kHz version
- Built in a watch dog timer (WDT)
- Low operating voltage: 2.0 ~ 3.6V (at 300kHz ~ 4MHz)

Table 2-1 GMS37XXX series members

Series	GMS37004	GMS37112	GMS37140
Program memory	1,024	1,024	1,024
Data memory	32 × 4	32 × 4	32 × 4
I/O ports	-	4	4
Input ports	4	4	4
Output ports	7 (D0~D6)	7 (D0~D6)	10 (D0~D9)
Package	16DIP/SOP	20DIP/SOP/SSOP	24Skinny DIP/SOP

Block Diagram

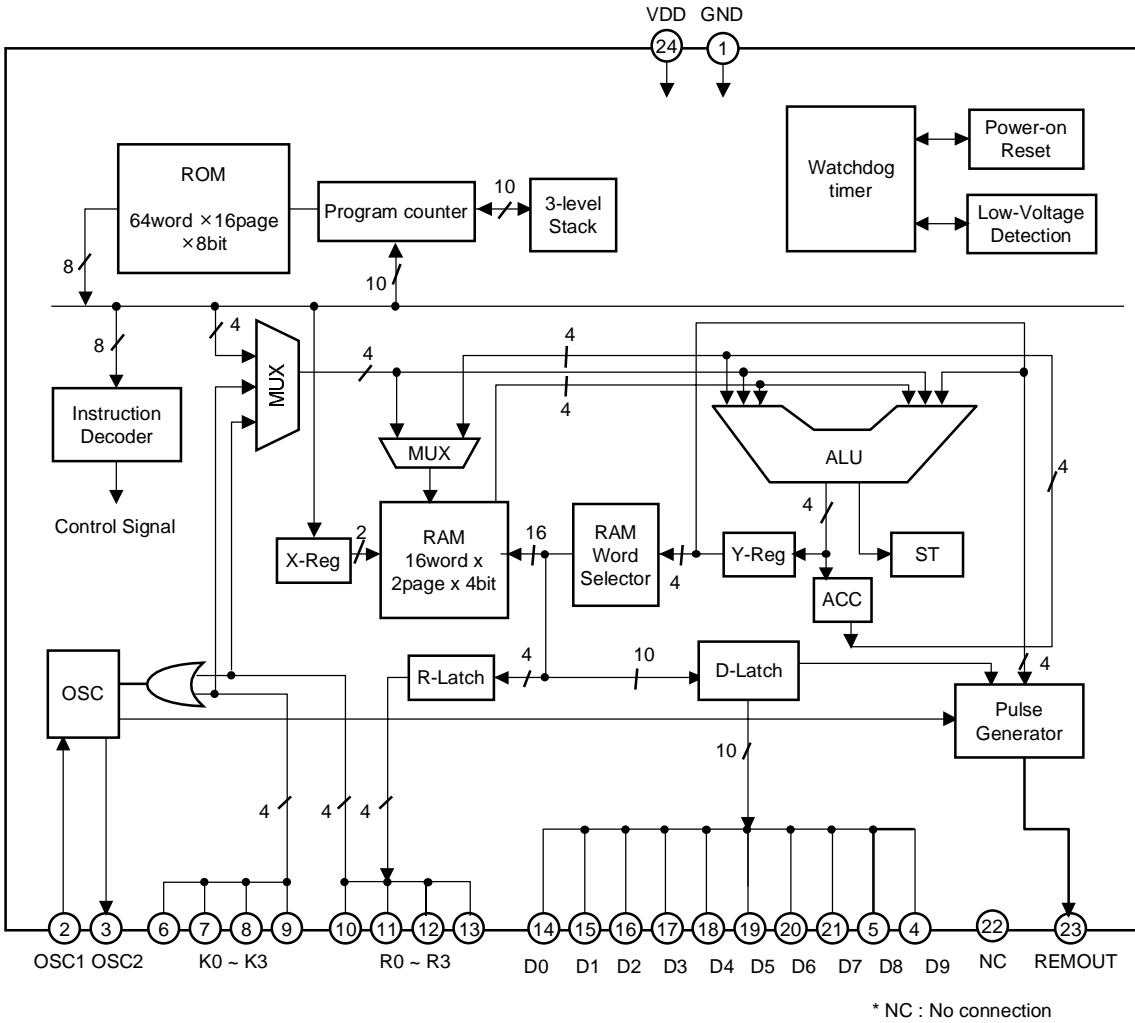

Fig 2-1 Block Diagram (In case of GMS37140)

Pin Assignment

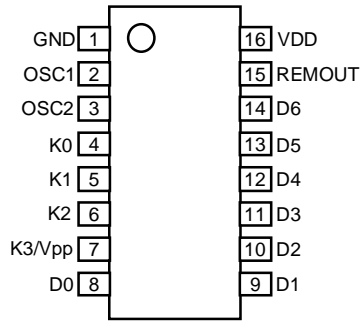

Fig 2-2 GMS37004 Pin Assignment (16DIP/SOP)

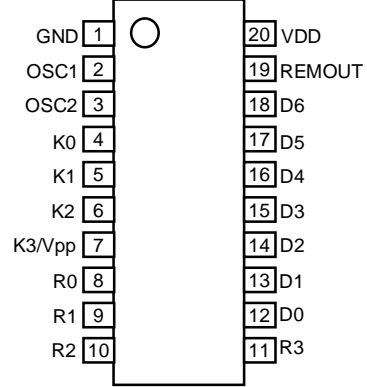

Fig 2-3 GMS37112 Pin Assignment (20DIP/SOP/SSOP)

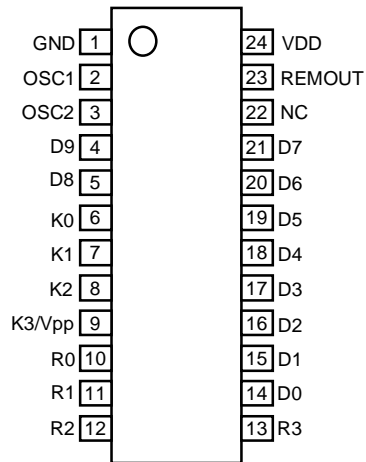

Fig 2-4 GMS37140 Pin Assignment (24Skinny-DIP/SOP)

## Pin Description

<b>Pin</b>	<b>I/O</b>	<b>Function</b>
VDD	-	Connected to 2.0~ 3.6V power supply
GND	-	Connected to 0V power supply.
K0 ~ K3	Input	4-bit input port with built in pull-up resistor. STOP mode is released by "L" input of each pin. ( masked option)
D0 ~ D9	Output	Each can be set and reset independently. The output is the structure of N-channel-open-drain.
R0 ~ R3	I/O	4-bit I/O port. (Input mode is set only when each of them output "H".) In outputting, each can be set and reset independently(or at once.) The output is in the form of C-MOS. Pull-up resistor and STOP release mode can be respectively selected as masked option for each pin. (It is released by "L" input at STOP)
OSC1	Input	Oscillator input. Input to the oscillator circuit and connection point for ceramic resonator. Internal capacitors available at kHz version. A feedback resistor is internally connected between this pin and OSC2.
OSC2	Output	Connect a resonator between this pin and OSC1.
REMOUT	Output	High current output port. The output is in the form of CMOS. The state of large current on is "H".

Pin Circuit

Pin	I/O	I/O circuit	Note
R0 ~ R3	I/O		<ul style="list-style-type: none"> <li>- CMOS output.</li> <li>- "H" output at reset.</li> </ul> (Option) - Built in MOS Tr for pull-up, about 140kΩ.
K0 ~ K3	I		<ul style="list-style-type: none"> <li>- Built in MOS Tr for pull-up, about 140kΩ.</li> </ul>
D0 ~ D9	O		<ul style="list-style-type: none"> <li>- Open drain output.</li> <li>- "L" output at reset.</li> </ul>
REMOUT	O		<ul style="list-style-type: none"> <li>- CMOS output.</li> <li>- "L" output at reset.</li> <li>- High current output source.</li> </ul>

Pin	I/O	I/O circuit	Note
OSC2	O		<ul style="list-style-type: none"> <li>- Built in feedback-resistor about <math>1\text{M}\Omega</math></li> <li>- Built in damping-resistor [No resistor in MHz operation]</li> </ul>
OSC1	I		<p>(Option)</p> <ul style="list-style-type: none"> <li>- Built in resonance capacitor at kHz version</li> <li>- <math>C1=C2 = 100\text{pF} \pm 15\%</math> [C1,C2 are not available for MHz version]</li> </ul>

## Port operation

Value of X-reg	Value of Y-reg	Operation
0 or 1	0 ~ 7	SO : D(Y) $\leftarrow$ 1 (High-Z) RO : D(Y) $\leftarrow$ 0
0 or 1	8	REMOUT port repeats "H" and "L" in pulse frequency. (when PMR = 5, it is fixed at "H" ) SO : REMOUT (PMR) $\leftarrow$ 1 RO : REMOUT (PMR) $\leftarrow$ 0
0 or 1	9	SO : D0 ~ D9 $\leftarrow$ 1 (High-Z) RO : D0 ~ D9 $\leftarrow$ 0
0 or 1	A ~ D	SO : R(Y-Ah) $\leftarrow$ 1 RO : R(Y-Ah) $\leftarrow$ 0
0 or 1	E	SO : R0 ~ R3 $\leftarrow$ 1 RO : R0 ~ R3 $\leftarrow$ 0
0 or 1	F	SO : D0 ~ D9 $\leftarrow$ 1 (High-Z), R0 ~ R3 $\leftarrow$ 1 RO : D0 ~ D9 $\leftarrow$ 0, R0 ~ R3 $\leftarrow$ 0
2 or 3	0	SO : D(8) $\leftarrow$ 1 (High-Z) RO : D(8) $\leftarrow$ 0
2 or 3	1	SO : D(9) $\leftarrow$ 1 (High-Z) RO : D(9) $\leftarrow$ 0

## Optional Features

The GMS37XXX series offer the following optional features.

Theses options are masked.

- I/O terminals having pull-up resistor : R0 ~ R3
- Input terminals having STOP release mode : K0 ~ K3, R0 ~ R3.
- Output form at STOP mode  
D0 ~ D9 : "L" or keep before stop mode.

Theses options are offered default.

- Ceramic oscillation circuit contained (or not contained)  
[ This option is not available for MHz Ceramic oscillator. ]
- Instruction cycle selection :  
T = 48 / f<sub>OSC</sub> or 6 / f<sub>OSC</sub>

Electrical Characteristics

Absolute maximum ratings (Ta = 25 °C)

Parameter	Symbol	Max. rating	Unit
Supply Voltage	V <sub>DD</sub>	-0.3 ~ 5.0	V
Power dissipation	P <sub>D</sub>	700 *	mW
Storage temperature range	Tstg	-55 ~ 125	°C
Input voltage	V <sub>IN</sub>	-0.3 ~ V <sub>DD</sub> +0.3	V
Output voltage	V <sub>OUT</sub>	-0.3 ~ V <sub>DD</sub> +0.3	V

\* Thermal derating above 25 °C : 6mW per degree °C rise in temperature.

Recommended operating condition

Parameter	Symbol	Condition	Rating	Unit
Supply Voltage	V <sub>DD</sub>	300KHz ~ 4MHz	2.0 ~ 3.6	V
Operating temperature	Topr	-	-20 ~ +70	°C



Electrical characteristics (Ta=25°C, V<sub>DD</sub>= 3V)

Parameter	Symbol	Limits			Unit	Condition	
		Min.	Typ.	Max.			
Input H current	I <sub>IH</sub>	-	-	1	uA	V <sub>i</sub> = V <sub>DD</sub> , R having no Pull-up	
Input L current	I <sub>IL</sub>	-1	-	-	uA	V <sub>i</sub> = GND, R having no Pull-up	
K Pull-up Resistance	R <sub>PU1</sub>	70	140	300	kΩ	V <sub>i</sub> = GND	
R Pull-up Resistance	R <sub>PU2</sub>	70	140	300	kΩ	V <sub>i</sub> = GND, Output off	
Feedback Resistance	R <sub>FD</sub>	0.3	1.0	3.0	MΩ	V <sub>OSC1</sub> = GND, V <sub>OSC2</sub> = GND	
K, R Input H voltage	V <sub>IH1</sub>	2.1	-	-	V	-	
K, R Input L voltage	V <sub>IL1</sub>	-	-	0.9	V	-	
D, R Output L voltage	V <sub>OL2</sub> <sup>*1</sup>	-	0.15	0.4	V	I <sub>OL2</sub> = 3mA	
OSC2 Output L voltage	V <sub>OL3</sub>	-	0.4	0.9	V	I <sub>OL3</sub> = 40uA (kHz), 150uA (MHz)	
OSC2 Output H voltage	V <sub>OH3</sub>	2.1	2.5	-	V	I <sub>OH3</sub> = -40uA (kHz), -150uA (MHz)	
REMOUT Output L current	I <sub>OL1</sub> <sup>*2</sup>	1	2.2	4	mA	V <sub>OL1</sub> = 0.4V	
REMOUT Output H current	I <sub>OH1</sub> <sup>*3</sup>	-5	-15	-30	mA	V <sub>OH1</sub> = 2V	
D, R Output leakage current	I <sub>OLK2</sub>	-	-	1	uA	V <sub>OUT</sub> = V <sub>DD</sub> , Output off	
Current on STOP mode	I <sub>STP</sub>	-	-	1	uA	At STOP mode	
Operating Supply current 1	I <sub>DD1</sub> <sup>*3</sup>	-	0.2	1.0	mA	f <sub>OSC</sub> = 455kHz	
Operating Supply current 2	I <sub>DD2</sub> <sup>*3</sup>	-	0.5	1.5	mA	f <sub>OSC</sub> = 4MHz	
System colck frequency	f <sub>OSC</sub> /6	f <sub>OSC</sub>	300	-	1000	kHz	kHz Version
	f <sub>OSC</sub> /48	f <sub>OSC</sub>	2.4	-	4	MHz	MHz Version.

\*1 Refer to < Fig.2-5 I<sub>OL2</sub> vs. V<sub>OL2</sub> Graph >

\*2 Refer to < Fig.2-6 I<sub>OL1</sub> vs. V<sub>OL1</sub> Graph >

\*3 Refer to < Fig.2-7 I<sub>OH1</sub> vs. V<sub>OH1</sub> Graph >

\*4 I<sub>DD1</sub>, I<sub>DD2</sub> is measured at RESET mode.

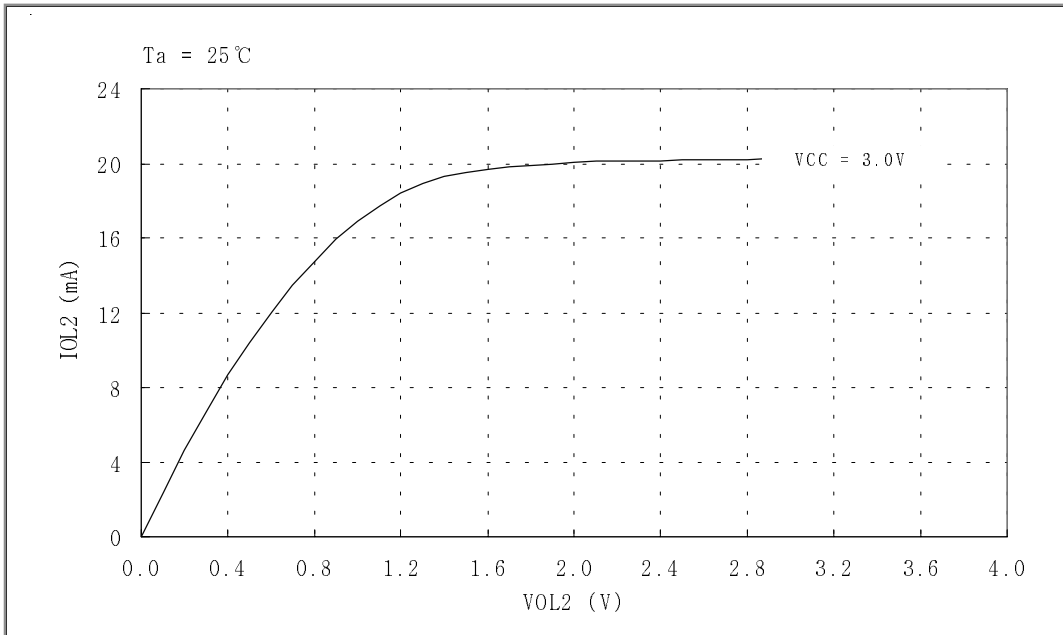

Fig 2-5.  $I_{OL2}$  vs.  $V_{OL2}$  Graph. (D, R Port)

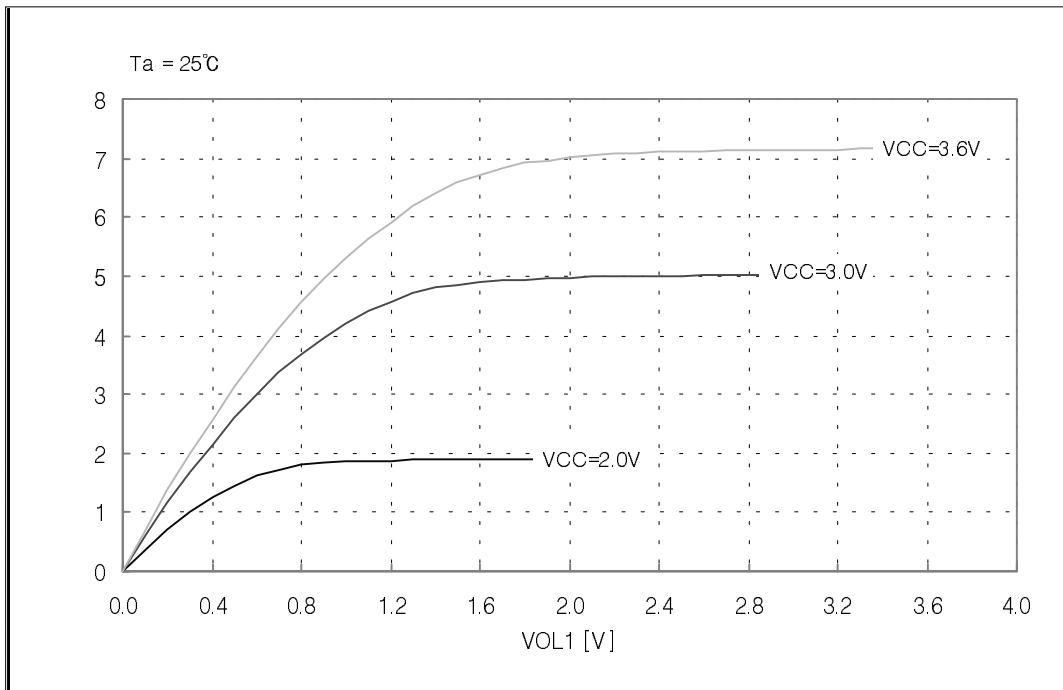

Fig 2-6.  $I_{OL1}$  vs  $V_{OL1}$  Graph (REMOUT Port)

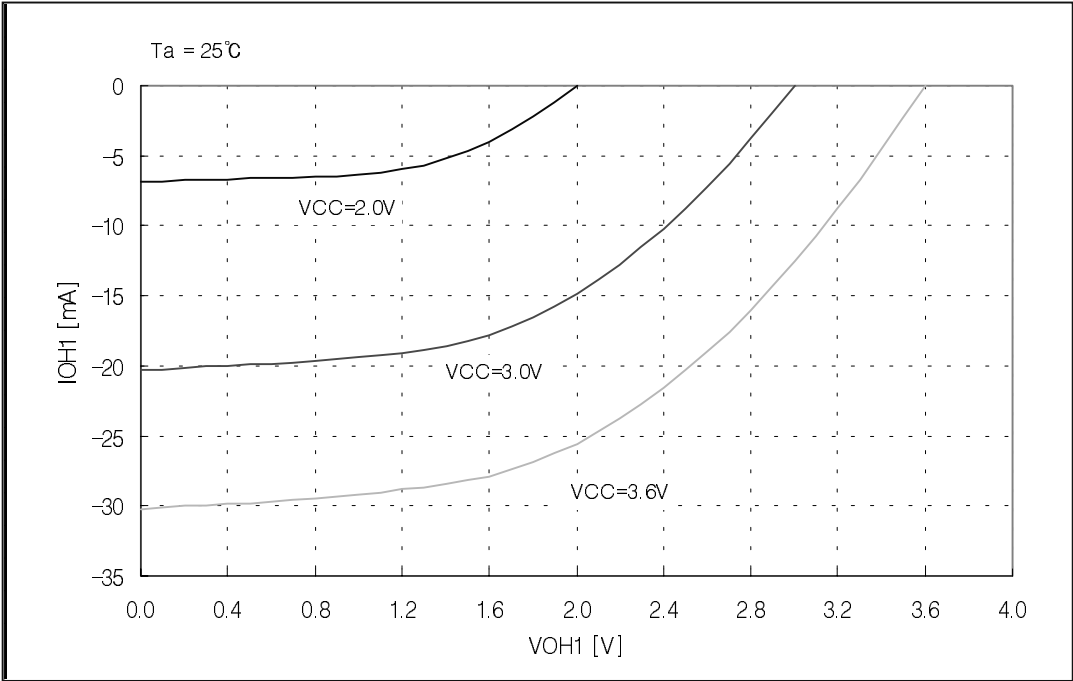

Fig 2-7.  $I_{OH1}$  vs  $V_{OH1}$  Graph (REMOUT Port)

---

<b>GMS36XXX</b>	<b>1</b>
<b>GMS37XXX</b>	<b>2</b>
<b>PACKAGE DIMENSIONS</b>	<b>3</b>
<b>FUNCTIONAL DESCRIPTION</b>	<b>4</b>
<b>INSTRUCTION</b>	<b>5</b>
<b>APPLICATION</b>	<b>6</b>
<b>GMS36XXXT</b>	<b>7</b>
<b>GMS37XXXT</b>	<b>8</b>
<b>EPROM</b>	<b>9</b>

---

### 3. PACKAGE DIMENSIONS

The GMS36/37XXX series can be used the following package dimesions.

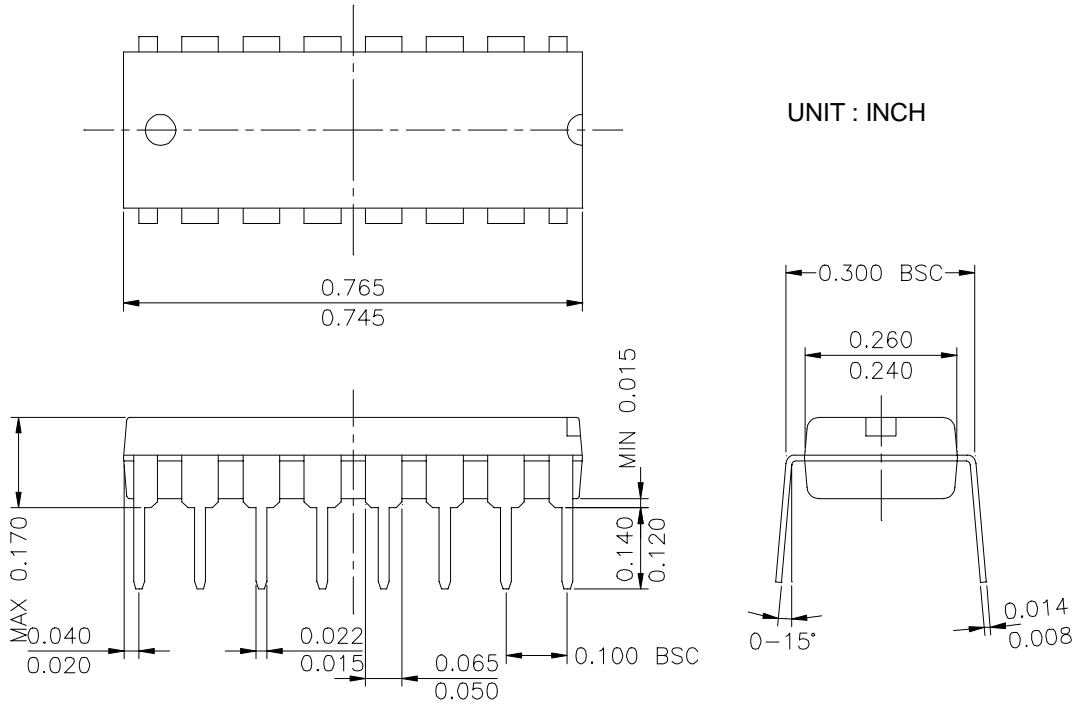

Fig 3-1. 16PDIP (300MIL)

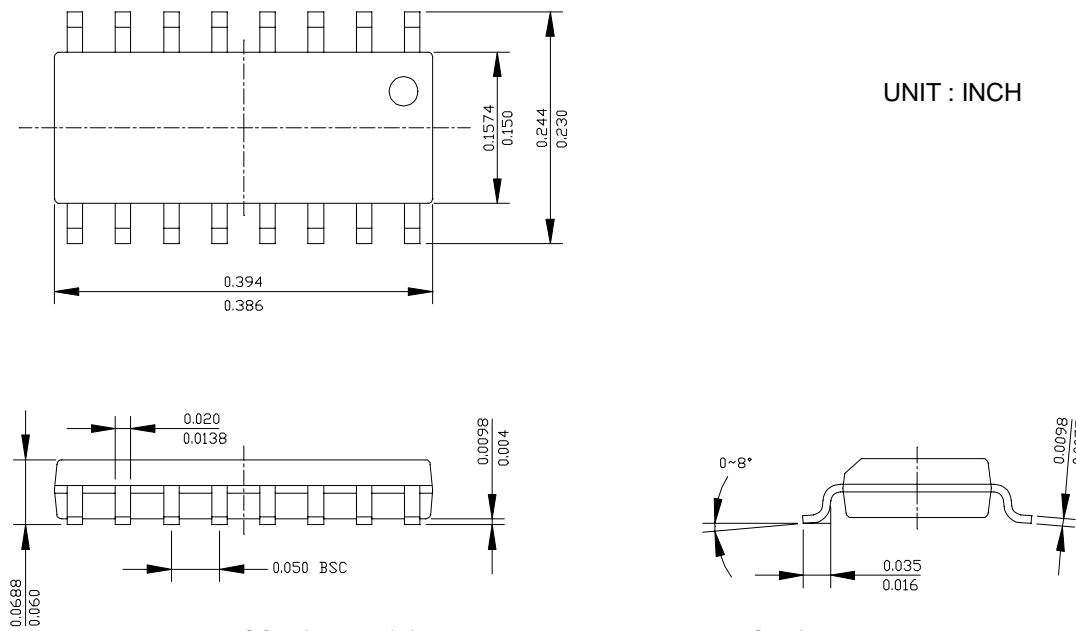
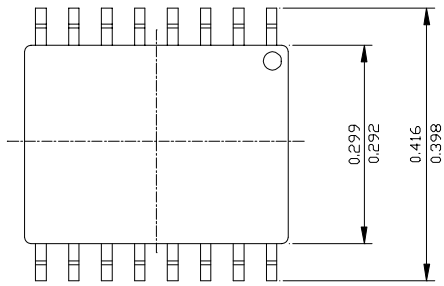

Fig 3-2. 16SOP (150MIL) (\* This type is not supported at OTP)

### Chapter 3. PACKAGE DIMENSIONS



UNIT : INCH

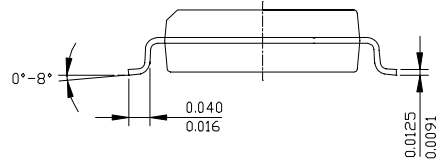
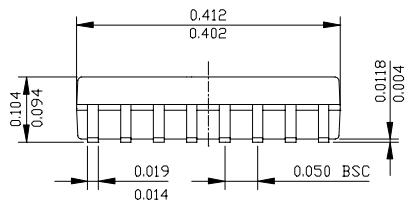
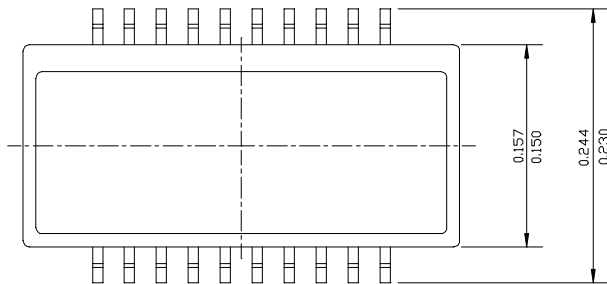

Fig 3-3. 16SOP (300MIL)



UNIT : INCH

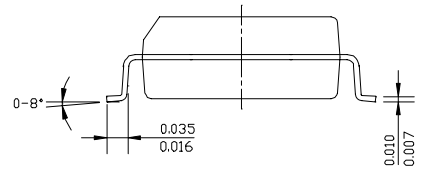
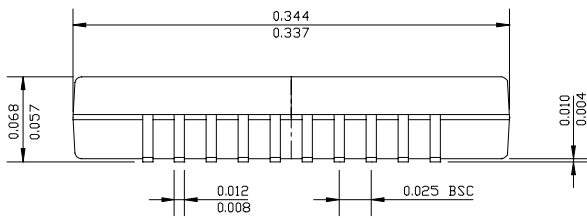

Fig 3-4. 20SSOP (150MIL)

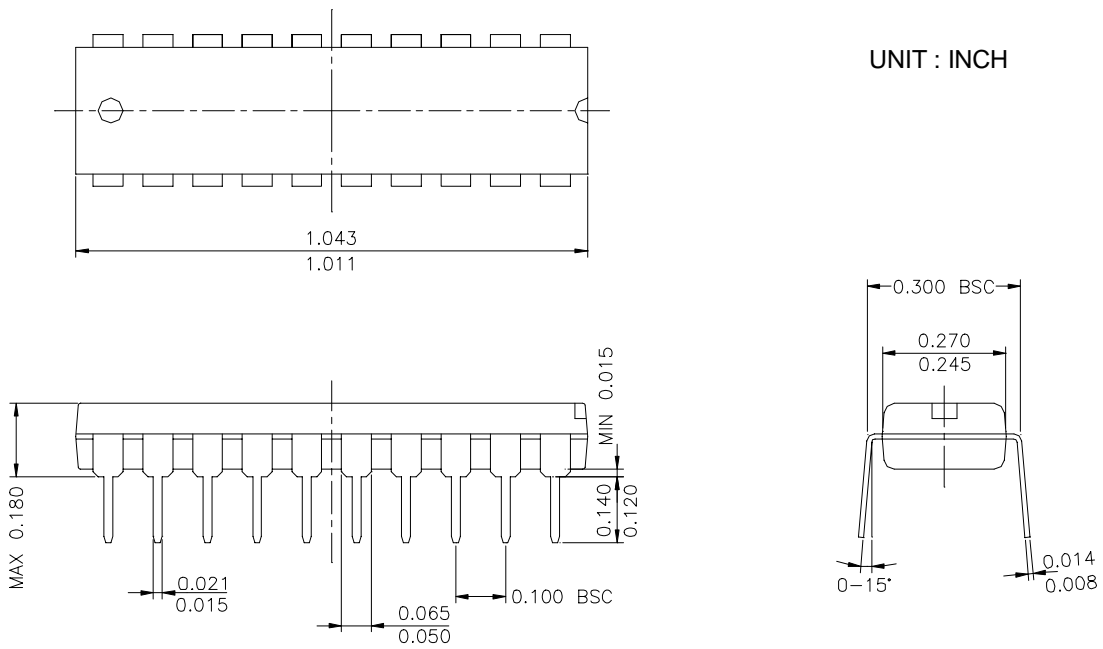

Fig 3-5. 20PDIP (300MIL)

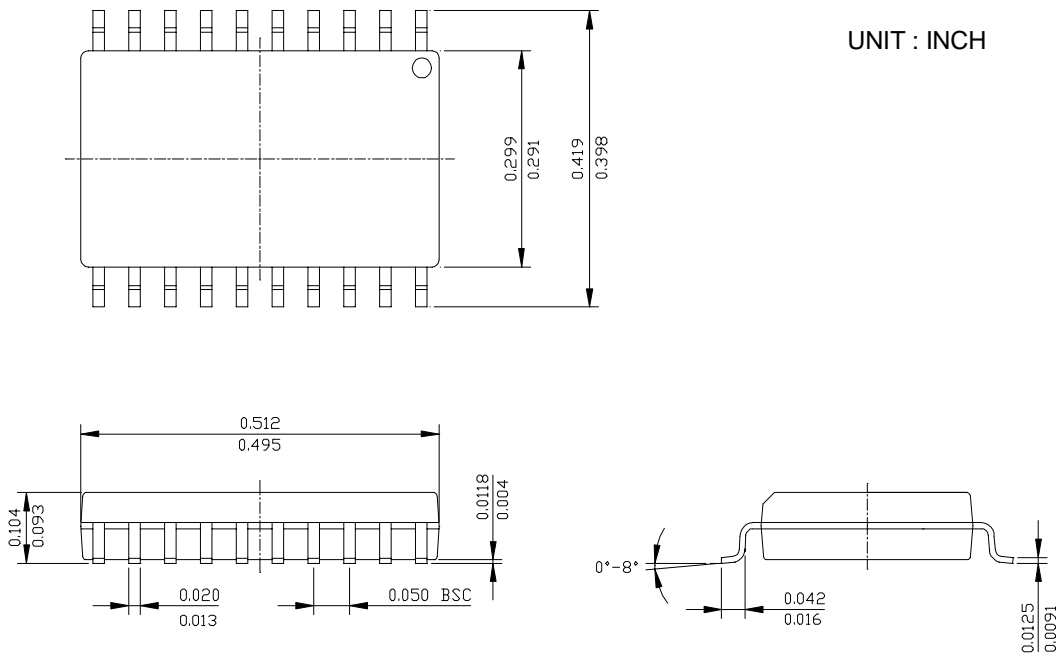

Fig 3-6. 20SOP (300MIL)

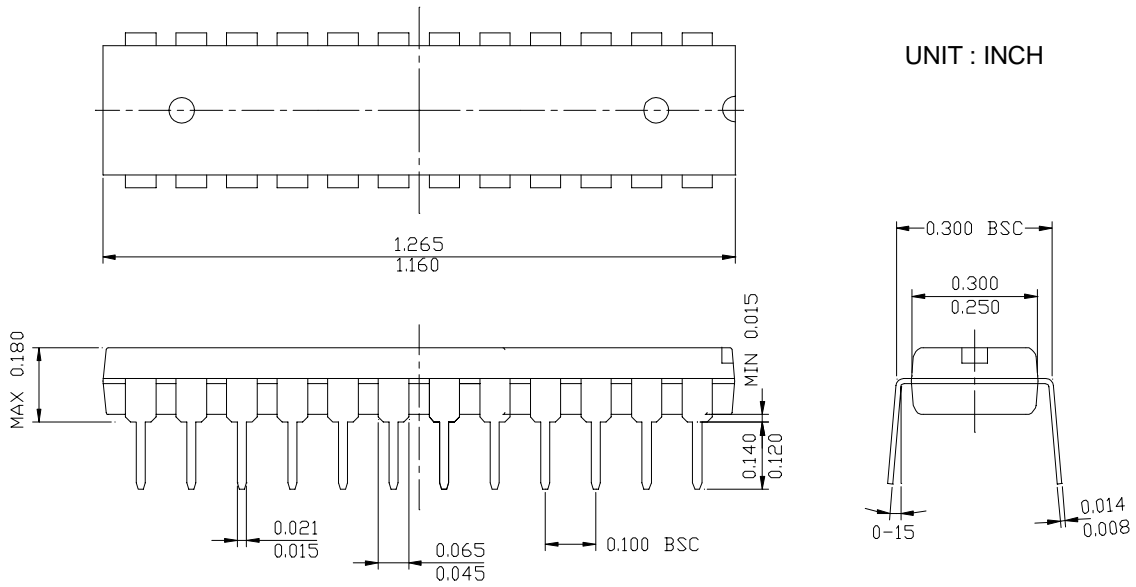

Fig 3-7. 24Skinny-DIP (300MIL)

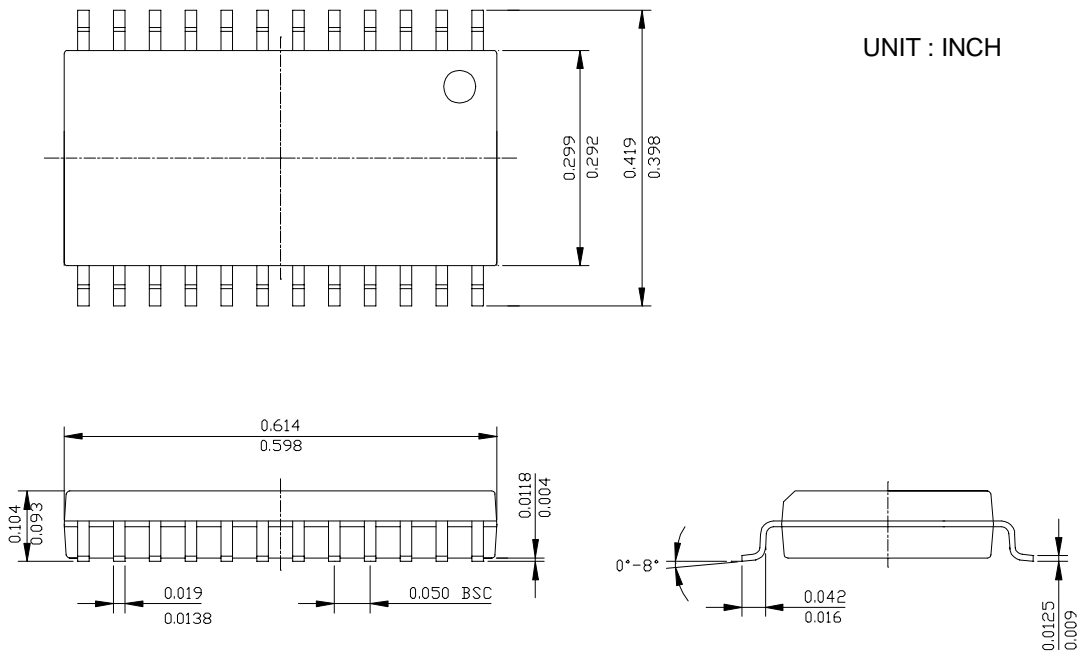

Fig 3-8. 24SOP (300MIL)



---

<b>GMS36XXX</b>	<b>1</b>
<b>GMS37XXX</b>	<b>2</b>
<b>PACKAGE DIMENSIONS</b>	<b>3</b>
<b>FUNCTIONAL DESCRIPTION</b>	<b>4</b>
<b>INSTRUCTION</b>	<b>5</b>
<b>APPLICATION</b>	<b>6</b>
<b>GMS36XXXT</b>	<b>7</b>
<b>GMS37XXXT</b>	<b>8</b>
<b>EPROM</b>	<b>9</b>

---

## 4. FUNCTIONAL DESCRIPTION

### Program Memory (ROM)

The GMS36/37XXX series can incorporate maximum 1,024 words (64 words × 16 pages × 8bits) for program memory. Program counter PC (A0~A5) and page address register (A6~A9) are used to address the whole area of program memory having an instruction (8bits) to be next executed.

The program memory consists of 64 words on each page, and thus each page can hold up to 64 steps of instructions.

The program memory is composed as shown below.

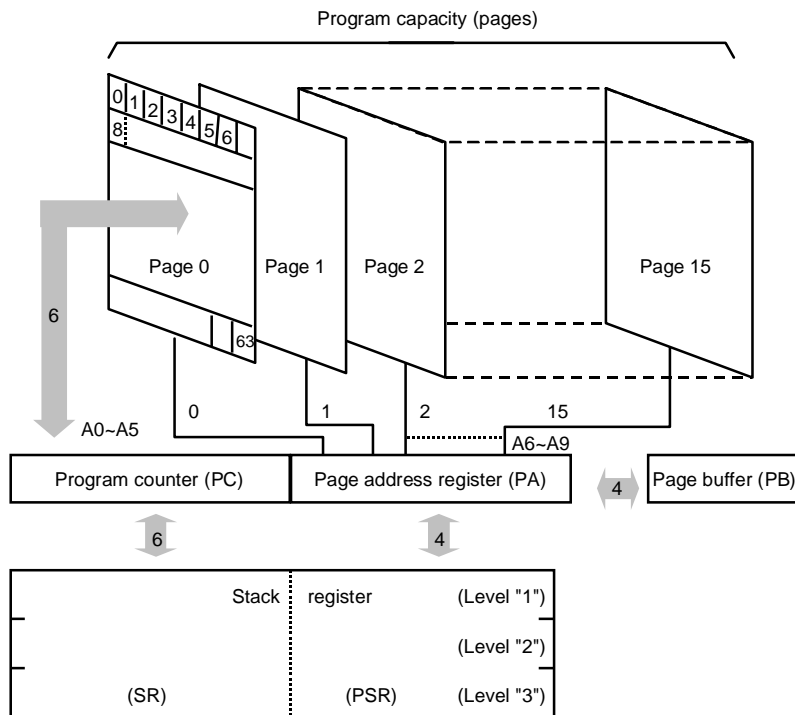

Fig 4-1 Configuration of Program Memory

### ROM Address Register

The following registers are used to address the ROM.

- Page address register (PA) :  
Holds ROM's page number (0 ~ Fh) to be addressed.
- Page buffer register (PB) :  
Value of PB is loaded by an LPBI command when newly addressing a page.  
Then it is shifted into the PA when rightly executing a branch instruction (BR) and a subroutine call (CAL).
- Program counter (PC) :  
Available for addressing word on each page.
- Stack register (SR) :  
Stores returned-word address in the subroutine call mode.

(1) Page address register and page buffer register :

Address one of pages #0 to #15 in the ROM by the 4-bit binary counter.

Unlike the program counter, the page address register is usually unchanged so that the program will repeat on the same page unless a page changing command is issued. To change the page address, take two steps such as (1) writing in the page buffer what page to jump (execution of LPBI) and (2) execution of BR or CAL, because instruction code is of eight bits so that page and word can not be specified at the same time.

In case a return instruction (RTN) is executed within the subroutine that has been called in the other page, the page address will be changed at the same time.

(2) Program counter :

This 6-bit binary counter increments for each fetch to address a word in the currently addressed page having an instruction to be next executed.

For easier programming, at turning on the power, the program counter is reset to the zero location. The PA is also set to "0". Then the program counter specifies the next ROM address in random sequence.

When BR, CAL or RTN instructions are decoded, the switches on each step are turned off not to update the address. Then, for BR or CAL, address data are taken in from the instruction operands ( $a_0$  to  $a_5$ ), or for RTN, and address is fetched from stack register No. 1.

(3) Stack register :

This stack register provides two stages each for the program counter (6bits) and the page address register (4bits) so that subroutine nesting can be made on two levels.

Data Memory (RAM)

Up to 32 nibbles (16 words × 2pages × 4bits) is incorporated for storing data. The whole data memory area is indirectly specified by a data pointer (X,Y). Page number is specified by zero bit of X register, and words in the page by 4 bits in Y-register. Data memory is composed in 16 nibbles/page. Figure 2-2 shows the configuration.

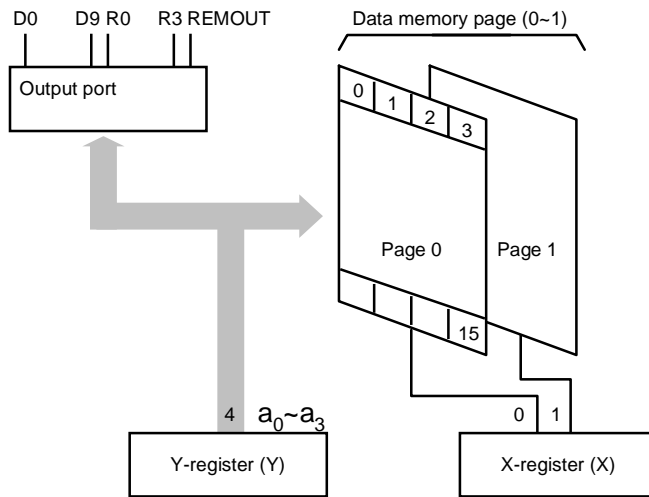

Fig 4-2 Composition of Data Memory

X-register (X)

X-register is consist of 2bit, X0 is a data pointer of page in the RAM, X1 is only used for selecting of D8 ~ D9 with value of Y-register

	X1=0	X1=1
Y=0	D0	D8
Y=1	D1	D9

Table 4-1 Mapping table between X and Y register

### Y-register (Y)

Y-register has 4 bits. It operates as a data pointer or a general-purpose register. Y-register specifies an address ( $a_0$ - $a_3$ ) in a page of data memory, as well as it is used to specify an output port. Further it is used to specify a mode of carrier signal outputted from the REMOUT port. It can also be treated as a general-purpose register on a program.

### Accumulator ( $A_{CC}$ )

The 4-bit register for holding data and calculation results.

### Arithmetic and Logic Unit (ALU)

In this unit, 4bits of adder/comparator are connected in parallel as it's main components and they are combined with status latch and status logic (flag.)

#### (1) Operation circuit (ALU) :

The adder/comparator serves fundamentally for full addition and data comparison. It executes subtraction by making a complement by processing an inversed output of  $A_{CC}$  ( $A_{CC}+1$ )

#### (2) Status logic :

This is to bring an ST, or flag to control the flow of a program. It occurs when a specified instruction is executed in three cases such as overflow or underflow in operation and two inputs unequal.

State Counter (SC)

A fundamental machine cycle timing chart is shown below. Every instruction is one byte length. Its execution time is the same. Execution of one instruction takes 6 clocks for fetch cycle and 6 clocks for execute cycle (12 clocks in total). Virtually these two cycles proceed simultaneously, and thus it is apparently completed in 6 clocks (one machine cycle). Exceptionally BR, CAL and RTN instructions is normal execution time since they change an addressing sequentially. Therefore, the next instruction is prefetched so that its execution is completed within the fetch cycle.

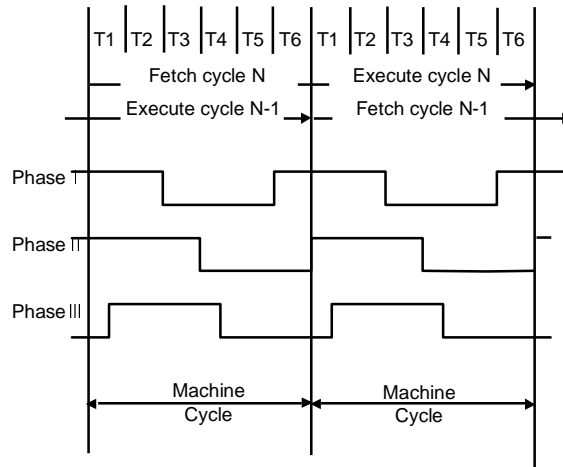
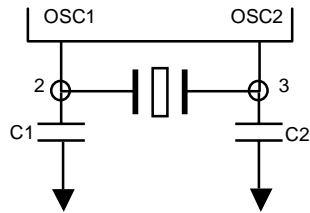

Fig. 4-3 Fundamental timing chart

**Clock Generator**

The GMS36/37XXX series has an internal clock oscillator. The oscillator circuit is designed to operate with an external ceramic resonator. Internal capacitors are available at kHz version. Oscillator circuit is able to organize by connecting ceramic resonator to outside.

\* It is necessary to connect capacitor to outside in order to change ceramic resonator, you must refer to a manufacturer's resonator matching guide.



GMS36/37112K	MURATA	CQ	Load cap.
429K	CSB429P	-	C1=C2=Open
432K	-	ZTB432	C1=C2=Open
455K	CSB455E	ZTB455	C1=C2=Open
480K	CSB480E	ZTB480	C1=C2=Open
500K	CSB500E	ZTB500	C1=C2=Open
640K	CSB640P	ZTB640	C1=C2=Open

GMS36/37112M	TDK	KYOCERA	Load cap.
3.64M	FCR3.64MSC5(15pF)	KBR-3.64MKE (33pF)	built in cap
	-	KBR-3.64MSE (33pF)	C1=C2=33pF
3.84M	FCR3.64MSC5(15pF)	KBR-3.84MKE (33pF)	built in cap
	-	KBR-3.84MSE (33pF)	C1=C2=33pF
4.00M	FCR4.0MSC5(15pF)	KBR-4.00MKE (33pF)	built in cap
	-	KBR-4.00MSE (33pF)	C1=C2=33pF

\* MURATA & CQ MHz type is under matching.

Pulse Generator

The following frequency and duty ratio are selected for carrier signal outputted from the REMOUT port depending on a PMR (Pulse Mode Register) value set in a program.

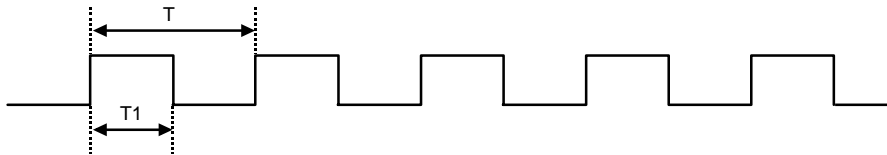

PMR	REMOUT signal
0	$T=1/f_{PUL} = 12/f_{OSC} [96/f_{OSC}]$ , $T1/T = 1/2$
1	$T=1/f_{PUL} = 12/f_{OSC} [96/f_{OSC}]$ , $T1/T = 1/3$
2	$T=1/f_{PUL} = 8/f_{OSC} [64/f_{OSC}]$ , $T1/T = 1/2$
3	$T=1/f_{PUL} = 8/f_{OSC} [64/f_{OSC}]$ , $T1/T = 1/4$
4	$T=1/f_{PUL} = 11/f_{OSC} [88/f_{OSC}]$ , $T1/T = 4/11$
5	No Pulse (same to D0 ~ D9)
6	$T=1/f_{PUL} = 12/f_{OSC} [96/f_{OSC}]$ , $T1/T = 1/4$
7	No pulse (same to D0 ~ D9)

\* Default value is "0"

\* [ ] means the value of "T", when Instruction cycle is  $f_{OSC}/48$  in MHz version

Table 4-2 PMR selection table



Reset Operation

GMS36/37XXX has three reset sources. One is a built-in Power-on reset circuit, another is a built-in Low VDD Detection circuit, the other is the overflow of Watch Dog Timer. (WDT) All reset operations are internal in the GMS36/37XXX.

Built-in Power On Reset Circuit

GMS36/37XXX has a built-in Power-on reset circuit consisting of an about  $1\text{M}\Omega$  Resistor and a  $3\text{pF}$  Capacitor. When the Power-on reset pulse occurs, system reset signal is latched and WDT is cleared. After the overflow time of WDT ( $2^{13}$  x System clock time) system reset signal is released.

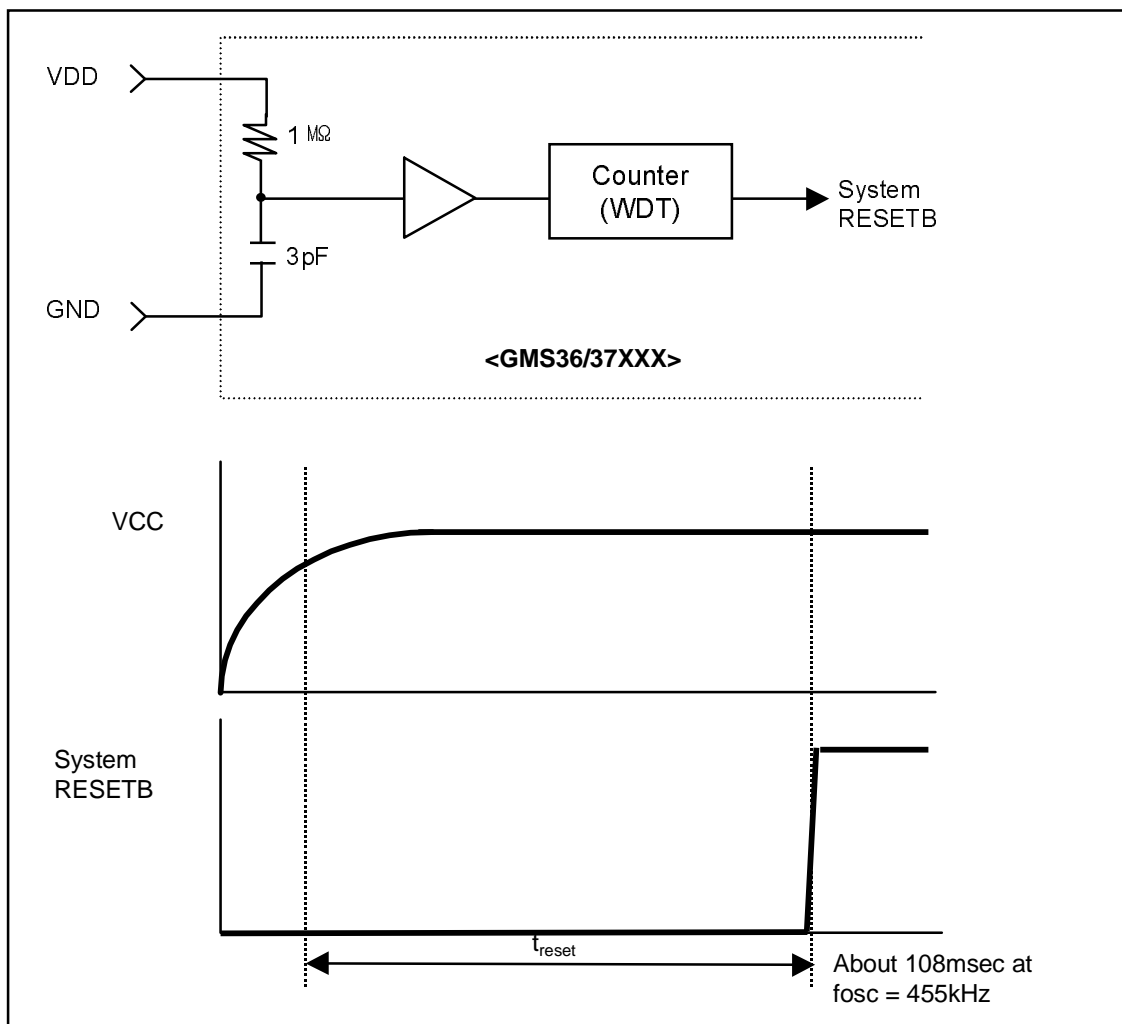

Fig. 4-4 Power-On Reset Circuit and Timing Chart

Built-in Low VDD Detection Circuit

GMS36/37XXX has a Low VDD detection circuit.

If VDD become Reset Voltage of Low VDD Detection circuit at active status, system reset occur and WDT is cleared. After VDD is increased upper Reset Voltage again, WDT is re-counted and if WDT is overflowed, system reset is released.

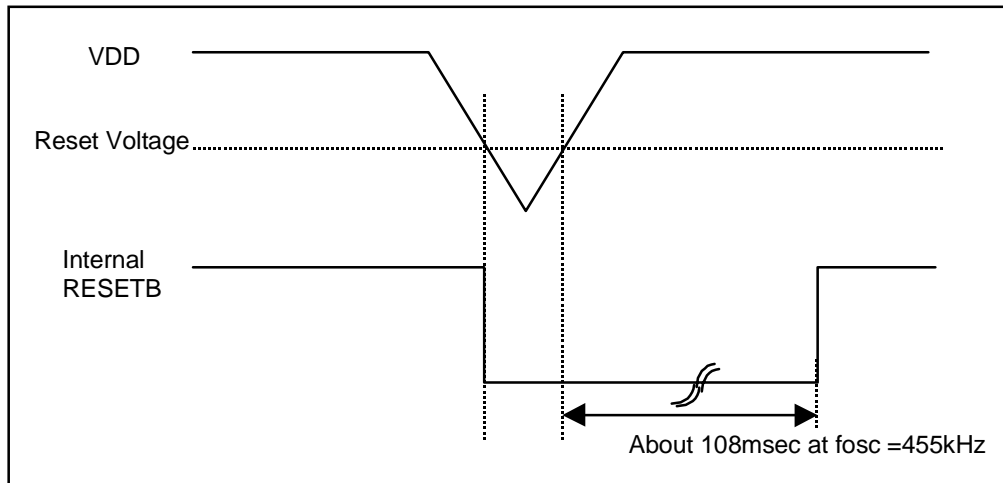

Fig. 4-5 Low Voltage Detection diagram

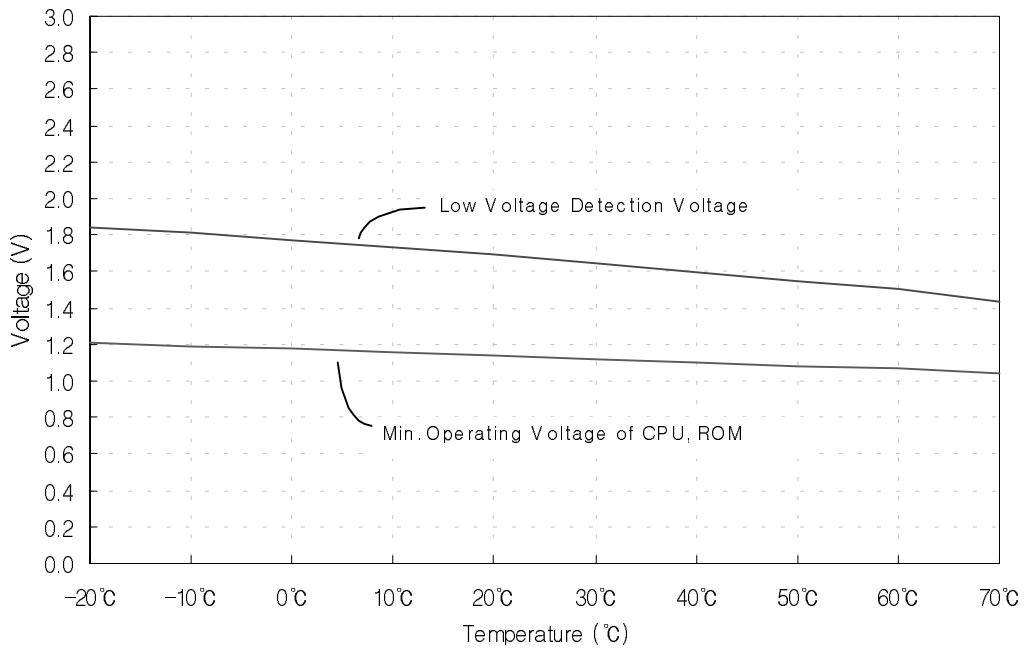

Fig. 4-6 Low Voltage vs Temperature

### Watch Dog Timer (WDT)

Watch dog timer is organized binary of 14 steps. The signal of  $f_{OSC}/6$  cycle comes in the first step of WDT after WDT reset. If this counter was overflowed, reset signal automatically come out so that internal circuit is initialized.

The overflow time is  $6 \times 2^{13}/f_{OSC}$  (108.026ms at  $f_{OSC}=455\text{KHz}$ .)

$8 \times 6 \times 2^{13}/f_{OSC}$  (108.026ms at  $f_{OSC} = 3.64\text{MHz}$ )

Normally, the binary counter must be reset before the overflow by using reset instruction (WDTR), Power-on reset pulse or Low VDD detection pulse.

\* It is constantly reset in STOP mode. When STOP is released, counting is restarted.

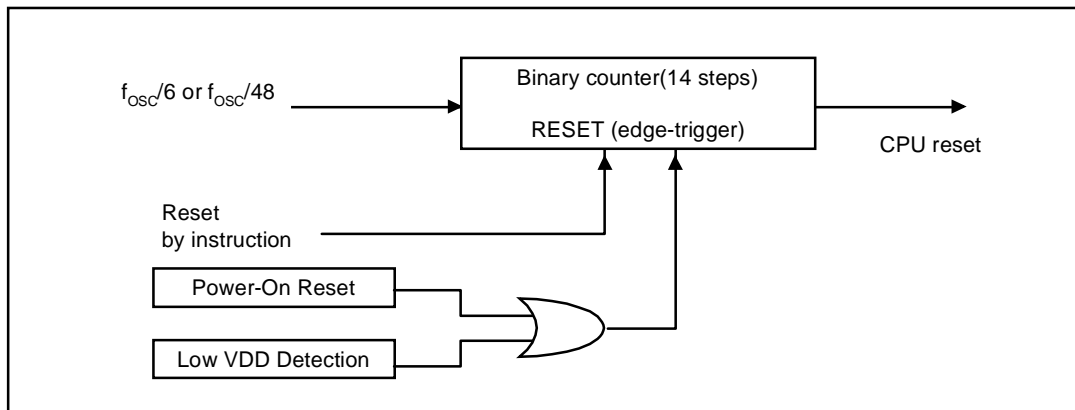

Fig. 4-7 Block Diagram of Watch-dog Timer

### STOP Operation

Stop mode can be achieved by STOP instructions.

In stop mode :

1. Oscillator is stopped, the operating current is low.
2. Watch dog timer is reset, REMOUT output is disable  
(High-Z at GMS36XXX(T) , "L" at GMS37XXX(T))
3. Part other than WDT and REMOUT output have a value before  
come into stop mode.

\* But the state of D0 ~ D9 output in stop mode is able to choose as masked option.

"L" output or same level before come into stop mode.

The Function to release stop mode is able to choose each bit of K or R input as masked option.

Stop mode is released when one of K or R input is going to "L".

1. State of D0 ~ D9 output and REMOUT output is return to state of before stop mode is  
achieved.
2. After  $2^{10} \times \{\text{System clock time}\}$  for stable oscillating, first instruction start to operate.
3. In return to normal operation, WDT is counted from zero again.

But, at executing stop instruction, if one of K or R input is chosen to "L", stop instruction  
is same to NOP instruction.

---

<b>GMS36XXX</b>	<b>1</b>
<b>GMS37XXX</b>	<b>2</b>
<b>PACKAGE DIMENSIONS</b>	<b>3</b>
<b>FUNCTIONAL DESCRIPTION</b>	<b>4</b>
<b>INSTRUCTION</b>	<b>5</b>
<b>APPLICATION</b>	<b>6</b>
<b>GMS36XXXT</b>	<b>7</b>
<b>GMS37XXXT</b>	<b>8</b>
<b>EPROM</b>	<b>9</b>

---

## CHAPTER 5. INSTRUCTION

### INSTRUCTION FORMAT

All of the 43 instruction in GMS36/37XXX(T) series is format in two fields of OP code and operand which consist of eight bits. The following formats are available with different types of operands.

\*Format I

All eight bits are for OP code without operand.

\*Format II

Two bits are for operand and six bits for OP code.

Two bits of operand are used for specifying bits of RAM and X-register (bit 1 and bit 7 are fixed at "0")

\*Format III

Four bits are for operand and the others are OP code.

Four bits of operand are used for specifying a constant loaded in RAM or Y-register, a comparison value of compare command, or page addressing in ROM.

\*Format IV

Six bits are for operand and the others are OP code.

Six bits of operand are used for word addressing in the ROM.

## Chapter 5. INSTRUCTION

---

### INSTRUCTION TABLE

The GMS36/37XXX(T) series provides the following 43 basic instructions.

	Category	Mnemonic	Function	ST <sup>1</sup>
1	Register to Register	LAY	$A \leftarrow Y$	S
2		LYA	$Y \leftarrow A$	S
3		LAZ	$A \leftarrow 0$	S
4	RAM to Register	LMA	$M(X,Y) \leftarrow A$	S
5		LMAIY	$M(X,Y) \leftarrow A, Y \leftarrow Y+1$	S
6		LYM	$Y \leftarrow M(X,Y)$	S
7		LAM	$A \leftarrow M(X,Y)$	S
8		XMA	$A \leftrightarrow M(X,Y)$	S
9	Immediate	LYI i	$Y \leftarrow i$	S
10		LMIIY i	$M(X,Y) \leftarrow i, Y \leftarrow Y+1$	S
11		LXI n	$X \leftarrow n$	S
12	RAM Bit Manipulation	SEM n	$M(n) \leftarrow 1$	S
13		REM n	$M(n) \leftarrow 0$	S
14		TM n	TEST $M(n) = 1$	E
15	ROM Address	BR a	if ST = 1 then Branch	S
16		CAL a	if ST = 1 then Subroutine call	S
17		RTN	Return from Subroutine	S
18		LPBI i	$PB \leftarrow i$	S
19	Arithmetic	AM	$A \leftarrow A + M(X,Y)$	C
20		SM	$A \leftarrow M(X,Y) - A$	B
21		IM	$A \leftarrow M(X,Y) + 1$	C
22		DM	$A \leftarrow M(X,Y) - 1$	B
23		IA	$A \leftarrow A + 1$	S
24		IY	$Y \leftarrow Y + 1$	C
25		DA	$A \leftarrow A - 1$	B

	Category	Mnemonic	Function	ST <sup>*1</sup>
26	Arithmetic	DY	$Y \leftarrow Y - 1$	B
27		EORM	$A \leftarrow A \oplus M(X,Y)$	S
28		NEGA	$A \leftarrow \bar{A} + 1$	Z
29	Comparison	ALEM	TEST $A \leq M(X,Y)$	E
30		ALEI i	TEST $A \leq i$	E
31		MNEZ	TEST $M(X,Y) \neq 0$	N
32		YNEA	TEST $Y \neq A$	N
33		YNEI i	TEST $Y \neq i$	N
34		KNEZ	TEST $K \neq 0$	N
35		RNEZ	TEST $R \neq 0$	N
36	Input / Output	LAK	$A \leftarrow K$	S
37		LAR	$A \leftarrow R$	S
38		SO	Output $\leftarrow$ 0 at GMS36XXX, 1 at GMS37XXX	S
39		RO	Output $\leftarrow$ 1 at GMS36XXX, 0 at GMS37XXX	S
40	Control	WDTR	Watch Dog Timer Reset	S
41		STOP	Stop operation	S
42		LPY	$PMR \leftarrow Y$	S
43		NOP	No operation	S

Note) i = 0~f, n = 0~3, a = 6bit PC Address

\*1 Column ST indicates conditions for changing status. Symbols have the following meanings

- S : On executing an instruction, status is unconditionally set.
- C : Status is only set when carry or borrow has occurred in operation.
- B : Status is only set when borrow has not occurred in operation.
- E : Status is only set when equality is found in comparison.
- N : Status is only set when equality is not found in comparison.
- Z : Status is only set when the result is zero.



### DETAILS OF INSTRUCTION SYSTEM

All 43 basic instructions of the GMS36/37XXX(T) Series are one by one described in detail below.

#### Description Form

Each instruction is headlined with its mnemonic symbol according to the instructions table given earlier.

Then, for quick reference, it is described with basic items as shown below. After that, detailed comment follows.

- Items :
  - Naming : Full spelling of mnemonic symbol
  - Status : Check of status function
  - Format : Categorized into I to IV
  - Operand : Omitted for Format I
  - Function

**(1) LAY**

Naming : Load Accumulator from Y-Register  
Status : Set  
Format : I  
Function :  $A \leftarrow Y$   
<Comment> Data of four bits in the Y-register is unconditionally transferred to the accumulator. Data in the Y-register is left unchanged.

**(2) LYA**

Naming : Load Y-register from Accumulator  
Status : Set  
Format : I  
Function :  $Y \leftarrow A$   
<Comment> Load Y-register from Accumulator

**(3) LAZ**

Naming : Clear Accumulator  
Status : Set  
Format : I  
Function :  $A \leftarrow 0$   
<Comment> Data in the accumulator is unconditionally reset to zero.

**(4) LMA**

Naming : Load Memory from Accumulator  
Status : Set  
Format : I  
Function :  $M(X,Y) \leftarrow A$   
<Comment> Data of four bits from the accumulator is stored in the RAM location addressed by the X-register and Y-register. Such data is left unchanged.

**(5) LMAIY**

Naming : Load Memory from Accumulator and Increment Y-Register  
Status : Set  
Format : I  
Function :  $M(X,Y) \leftarrow A, Y \leftarrow Y+1$   
<Comment> Data of four bits from the accumulator is stored in the RAM location addressed by the X-register and Y-register. Such data is left unchanged.

**(6) LYM**

Naming : Load Y-Register form Memory  
Status : Set  
Format : I  
Function :  $Y \leftarrow M(X,Y)$   
<Comment> Data from the RAM location addressed by the X-register and Y-register is loaded into the Y-register. Data in the memory is left unchanged.

**(7) LAM**

Naming : Load Accumulator from Memory  
Status : Set  
Format : I  
Function :  $A \leftarrow M(X,Y)$   
<Comment> Data from the RAM location addressed by the X-register and Y-register is loaded into the Y-register. Data in the memory is left unchanged.

**(8) XMA**

Naming : Exchanged Memory and Accumulator  
Status : Set  
Format : I  
Function :  $M(X,Y) \leftrightarrow A$   
<Comment> Data from the memory addressed by X-register and Y-register is exchanged with data from the accumulator. For example, this instruction is useful to fetch a memory word into the accumulator for operation and store current data from the accumulator into the RAM. The accumulator can be restored by another XMA instruction.

**(9) LYI i**

Naming : Load Y-Register from Immediate  
Status : Set  
Format : III  
Operand : Constant  $0 \leq i \leq 15$   
Function :  $Y \leftarrow i$   
<Purpose> To load a constant in Y-register. It is typically used to specify Y-register in a particular RAM word address, to specify the address of a selected output line, to set Y-register for specifying a carrier signal outputted from OUT port, and to initialize Y-register for loop control. The accumulator can be restored by another XMA instruction.  
<Comment> Data of four bits from operand of instruction is transferred to the Y-register.

**(10) LMIY i**

Naming : Load Memory from Immediate and Increment Y-Register  
Status : Set  
Format : III  
Operand : Constant  $0 \leq i \leq 15$   
Function :  $M(X,Y) \leftarrow i, Y \leftarrow Y + 1$   
<Comment> Data of four bits from operand of instruction is stored into the RAM location addressed by the X-register and Y-register. Then data in the Y-register is incremented by one.

**(11) LXI n**

Naming : Load X-Register from Immediate  
Status : Set  
Format : II  
Operand : X file address  $0 \leq n \leq 3$   
Function :  $X \leftarrow n$   
<Comment> A constant is loaded in X-register. It is used to set X-register in an index of desired RAM page. Operand of 1 bit of command is loaded in X-register.

**(12) SEM n**

Naming : Set Memory Bit  
Status : Set  
Format : II  
Operand : Bit address  $0 \leq n \leq 3$   
Function :  $M(X,Y,n) \leftarrow 1$   
<Comment> Depending on the selection in operand of operand, one of four bits is set as logic 1 in the RAM memory addressed in accordance with the data of the X-register and Y-register.

**(13) REM n**

Naming : Reset Memory Bit  
Status : Set  
Format : II  
Operand : Bit address  $0 \leq n \leq 3$   
Function :  $M(X,Y,n) \leftarrow 0$   
<Comment> Depending on the selection in operand of operand, one of four bits is set as logic 0 in the RAM memory addressed in accordance with the data of the X-register and Y-register.

**(14) TM n**

Naming : Test Memory Bit  
Status : Comparison results to status  
Format : II  
Operand : Bit address  $0 \leq n \leq 3$   
Function :  $M(X,Y,n) \leftarrow 1?$   
 $ST \leftarrow 1$  when  $M(X,Y,n)=1$ ,  $ST \leftarrow 0$  when  $M(X,Y,n)=0$   
<Purpose> A test is made to find if the selected memory bit is logic. 1  
Status is set depending on the result.

**(15) BR a**

Naming : Branch on status 1  
Status : Conditional depending on the status  
Format : IV  
Operand : Branch address a (Addr)  
Function : When  $ST = 1$ ,  $PA \leftarrow PB$ ,  $PC \leftarrow a(\text{Addr})$   
When  $ST = 0$ ,  $PC \leftarrow PC + 1$ ,  $ST \leftarrow 1$   
Note : PC indicates the next address in a fixed sequence that is actually pseudo-random count.  
<Purpose> For some programs, normal sequential program execution can be change.  
A branch is conditionally implemented depending on the status of results obtained by executing the previous instruction.  
<Comment> 

- Branch instruction is always conditional depending on the status.
  - a. If the status is reset (logic 0), a branch instruction is not rightly executed but the next instruction of the sequence is executed.
  - b. If the status is set (logic 1), a branch instruction is executed as follows.
- Branch is available in two types - short and long. The former is for addressing in the current page and the latter for addressing in the other page. Which type of branch to execute is decided according to the PB register. To execute a long branch, data of the PB register should in advance be modified to a desired page address through the LPBI instruction.

**(16) CAL a**

Naming : Subroutine Call on status 1  
Status : Conditional depending on the status  
Format : IV  
Operand : Subroutine code address a(Addr)  
Function :  
When ST = 1 , PC  $\leftarrow$  a(Addr)          PA  $\leftarrow$  PB  
                                 SR1  $\leftarrow$  PC + 1,          PSR1  $\leftarrow$  PA  
                                 SR2  $\leftarrow$  SR1                  PSR2  $\leftarrow$  PSR1  
                                 SR3  $\leftarrow$  SR2                  PSR3  $\leftarrow$  PSR2  
When ST = 0 PC  $\leftarrow$  PC + 1          PB  $\leftarrow$  PS    ST  $\leftarrow$  1

Note : PC actually has pseudo-random count against the next instruction.

<Comment>      • In a program, control is allowed to be transferred to a mutual subroutine. Since a call instruction preserves the return address, it is possible to call the subroutine from different locations in a program, and the subroutine can return control accurately to the address that is preserved by the use of the call return instruction (RTN).  
Such calling is always conditional depending on the status.

- a. If the status is reset, call is not executed.
- b. If the status is set, call is rightly executed.

The subroutine stack (SR) of three levels enables a subroutine to be manipulated on three levels. Besides, a long call (to call another page) can be executed on any level.

- For a long call, an LPBI instruction should be executed before the CAL. When LPBI is omitted (and when PA=PB), a short call (calling in the same page) is executed.

**(17) RTN**

Naming : Return from Subroutine  
Status : Set  
Format : |  
Function : PC ← SR1            PA, PB ← PSR1  
          SR1 ← SR2        PSR1 ← PSR2  
          SR2 ← SR3        PSR2 ← PSR3  
          SR3 ← SR3        PSR3 ← PSR2  
                          ST ← 1

<Purpose> Control is returned from the called subroutine to the calling program.

<Comment> Control is returned to its home routine by transferring to the PC the data of the return address that has been saved in the stack register (SR1).  
At the same time, data of the page stack register (PSR1) is transferred to the PA and PB.

**(18) LPBI i**

Naming : Load Page Buffer Register from Immediate  
Status : Set  
Format : III  
Operand : ROM page address  $0 \leq i \leq 15$   
Function : PB ← i

<Purpose> A new ROM page address is loaded into the page buffer register (PB).  
This loading is necessary for a long branch or call instruction.

<Comment> The PB register is loaded together with three bits from 4 bit operand.

**(19) AM**

Naming : Add Accumulator to Memory and Status 1 on Carry  
Status : Carry to status  
Format : |  
Function :  $A \leftarrow M(X,Y)+A, ST \leftarrow 1(\text{when total} > 15),$   
                           $ST \leftarrow 0 (\text{when total} \leq 15)$

<Comment> Data in the memory location addressed by the X and Y-register is added to data of the accumulator. Results are stored in the accumulator. Carry data as results is transferred to status. When the total is more than 15, a carry is caused to put "1" in the status. Data in the memory is not changed.

**(20) SM**

Naming : Subtract Accumulator to Memory and Status 1 Not Borrow  
 Status : Carry to status

Format : |  
 Function :  $A \leftarrow M(X,Y) - A$              $ST \leftarrow 1(\text{when } A \leq M(X,Y))$   
     $ST \leftarrow 0(\text{when } A > M(X,Y))$

<Comment> Data of the accumulator is, through a 2's complemental addition, subtracted from the memory word addressed by the Y-register. Results are stored in the accumulator. If data of the accumulator is less than or equal to the memory word, the status is set to indicate that a borrow is not caused. If more than the memory word, a borrow occurs to reset the status to "0".

**(21) IM**

Naming : Increment Memory and Status 1 on Carry  
 Status : Carry to status

Format : |  
 Function :  $A \leftarrow M(X,Y) + 1$              $ST \leftarrow 1(\text{when } M(X,Y) \geq 15)$   
     $ST \leftarrow 0(\text{when } M(X,Y) < 15)$

<Comment> Data of the memory addressed by the X and Y-register is fetched. Adding 1 to this word, results are stored in the accumulator. Carry data as results is transferred to the status. When the total is more than 15, the status is set. The memory is left unchanged.

**(22) DM**

Naming : Decrement Memory and Status 1 on Not Borrow  
 Status : Carry to status

Format : |  
 Function :  $A \leftarrow M(X,Y) - 1$              $ST \leftarrow 1(\text{when } M(X,Y) \geq 1)$   
     $ST \leftarrow 0(\text{when } M(X,Y) = 0)$

<Comment> Data of the memory addressed by the X and Y-register is fetched, and one is subtracted from this word (addition of Fh)> Results are stored in the accumulator. Carry data as results is transferred to the status. If the data is more than or equal to one, the status is set to indicate that no borrow is caused. The memory is left unchanged.









**(32) YNEA**

Naming : Y-Register Not Equal Accumulator  
 Status : Comparison results to status  
 Format : |  
 Function :  $Y \neq A$   $ST \leftarrow 1$  (when  $Y \neq A$ )  
 $ST \leftarrow 0$  (when  $Y = A$ )  
 <Purpose> Data of Y-register and accumulator are compared to check if they are not equal.  
 <Comment> Data of the Y-register and accumulator are logically compared. Results are transferred to the status. Unless they are equal, the status is set.

**(33) YNEI**

Naming : Y-Register Not Equal Immediate  
 Status : Comparison results to status  
 Format : |||  
 Operand : Constant  $0 \leq i \leq 15$   
 Function :  $Y \neq i$   $ST \leftarrow 1$  (when  $Y \neq i$ )  
 $ST \leftarrow 0$  (when  $Y = i$ )  
 <Comment> The constant of the Y-register is logically compared with 4bit operand. Results are transferred to the status. Unless the operand is equal to the constant, the status is set.

**(34) KNEZ**

Naming : K Not Equal Zero  
 Status : The status is set only when not equal  
 Format : |  
 Function : When  $K \neq 0$ ,  $ST \leftarrow 1$   
 <Purpose> A test is made to check if K is not zero.  
 <Comment> Data on K are compared with zero. Results are transferred to the status. For input data not equal to zero, the status is set.

**(35) RNEZ**

Naming : R Not Equal Zero  
 Status : The status is set only when not equal  
 Format : |  
 Function : When  $R \neq 0$ ,  $ST \leftarrow 1$   
 <Purpose> A test is made to check if R is not zero.  
 <Comment> Data on R are compared with zero. Results are transferred to the status. For input data not equal to zero, the status is set.

**(36) LAK**

Naming : Load Accumulator from K  
 Status : Set  
 Format : |  
 Function :  $A \leftarrow K$   
 <Comment> Data on K are transferred to the accumulator

**(37) LAR**

Naming : Load Accumulator from R  
 Status : Set  
 Format : |  
 Function :  $A \leftarrow R$   
 <Comment> Data on R are transferred to the accumulator

**(38) SO**

Naming : Set Output Register Latch  
 Status : Set  
 Format : |  
 Function :  $D(Y) \leftarrow 1$   $0 \leq Y \leq 7$   
 $REMOUT \leftarrow 0(PMR=5)$   $Y = 8$  at GMS36XXX(T)  
 $REMOUT \leftarrow 1(PMR=5)$   $Y = 8$  at GMS37XXX(T)  
 $D0\sim D9 \leftarrow 1$  (High-Z)  $Y = 9$   
 $R(Y) \leftarrow 1$   $Ah \leq Y \leq Dh$   
 $R \leftarrow 1$   $Y = Eh$   
 $D0\sim D9, R \leftarrow 1$   $Y = Fh$

<Purpose> A single D output line is set to logic 1, if data of Y-register is between 0 to 7.  
 Carrier frequency come out from REMOUT port, if data of Y-register is 8.  
 All D output line is set to logic 1, if data of Y-register is 9.  
 It is no operation, if data of Y-register between 10 to 15.  
 When Y is between Ah and Dh, one of R output lines is set at logic 1.  
 When Y is Eh, the output of R is set at logic 1.  
 When Y is Fh, the output D0~D9 and R are set at logic 1.

<Comment> Data of Y-register is between 0 to 7, selects appropriate D output.  
 Data of Y-register is 8, selects REMOUT port.  
 Data of Y-register is 9, selects all D port.  
 Data in Y-register, when between Ah and Dh, selects an appropriate R output (R0~R3).  
 Data in Y-register, when it is Eh, selects all of R0~R3.  
 Data in Y-register, when it is Fh, selects all of D0~D9 and R0~R3.

**(39) RO**

Naming : Reset Output Register Latch

Status : Set

Format : |

Function :  $D(Y) \leftarrow 0$   $0 \leq Y \leq 7$   
 $REMOUT \leftarrow 1$   $Y = 8$  at GMS36XXX(T)  
 $REMOUT \leftarrow 0$   $Y = 8$  at GMS37XXX(T)  
 $D0 \sim D9 \leftarrow 0$   $Y = 9$   
 $R(Y) \leftarrow 0$   $Ah \leq Y \leq Dh$   
 $R \leftarrow 0$   $Y = Eh$   
 $D0 \sim D9, R \leftarrow 0$   $Y = Fh$

<Purpose> A single D output line is set to logic 0, if data of Y-register is between 0 to 9.

REMOUT port is set to logic 0, if data of Y-register is 9.

All D output line is set to logic 0, if data of Y-register is 9.

When Y is between Ah and Dh, one of R output lines is set at logic 0.

When Y is Eh, the output of R is set at logic 0

When Y is Fh, the output D0~D9 and R are set at logic 1.

<Comment> Data of Y-register is between 0 to 7, selects appropriate D output.

Data of Y-register is 8, selects REMOUT port.

Data of Y-register is 9, selects D port.

Data in Y-register, when between Ah and Dh, selects an appropriate R output (R0~R3).

Data in Y-register, when it is Eh, selects all of R0~R3.

Data in Y-register, when it is Fh, selects all of D0~D9 and R0~R3.

**(40) WDTR**

Naming : Watch Dog Timer Reset

Status : Set

Format : |

Function : Reset Watch Dog Timer (WDT)

<Purpose> Normally, you should reset this counter before overflowed counter for dc watch dog timer. this instruction controls this reset signal.

**(41) STOP**

Naming : STOP  
Status : Set  
Format : |  
Function : Operate the stop function  
<Purpose> Stopped oscillator, and little current.  
(See 1-12 page, STOP function.)

**(42) LPY**

Naming : Pulse Mode Set  
Status : Set  
Format : |  
Function :  $PMR \leftarrow Y$   
<Comment> Selects a pulse signal outputted from REMOUT port.

**(43) NOP**

Naming : No Operation  
Status : Set  
Format : |  
Function : No operation

---

<b>GMS36XXX</b>	<b>1</b>
<b>GMS37XXX</b>	<b>2</b>
<b>PACKAGE DIMENSIONS</b>	<b>3</b>
<b>FUNCTIONAL DESCRIPTION</b>	<b>4</b>
<b>INSTRUCTION</b>	<b>5</b>
<b>APPLICATION</b>	<b>6</b>
<b>GMS36XXXT</b>	<b>7</b>
<b>GMS37XXXT</b>	<b>8</b>
<b>EPROM</b>	<b>9</b>

---



Guideline for S/W

1. All rams need to be initialized to zero in reset address for proper design.
2. Make the output ports `H` after reset.
3. Do not use WDTR instruction in subroutine.
4. Before reading the input port the waiting time should be more than 200uS.
5. To decrease current consumption, make the output port as high in normal routine except for key scan strobe and STOP mode.
6. We recommend you do not use all 64 bytes in a page. You had better write `BR \$` in unused area. This will help you prevent unusual operation of MCU.
7. Be careful not to use long call or branch (CALL,BL) with arithmetic manipulation.  
If you want to use branch right after arithmetic manipulation, the long call or branch will be against your intention.

ex) LAR ; The value of R ports -> Accumulator  
ALEI 14 ; A≤14 : S = 1, A > 14 : S = 0  
BL TRUE ; S is always 1 because BL is composed of LPBI and BR.  
----- Fail

LAR ; The value of R ports -> Accumulator  
ALEI 14 ; A≤14 : S = 1, A > 14 : S = 0  
BR TRUE ; When S is 1 Branch will occur. Otherwise Branch will not occur and  
LAK ; next instruction will be operated.  
----- Right

GMS36112 Circuit Diagram

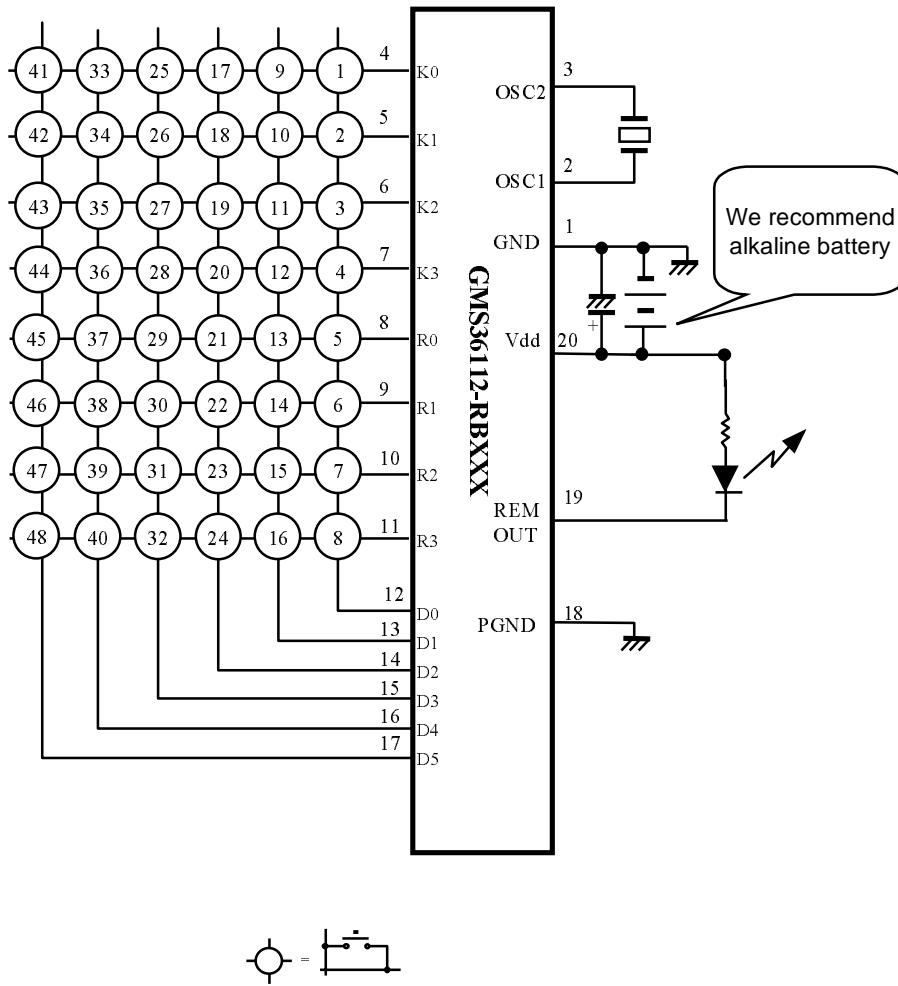

GMS37112 Circuit Diagram

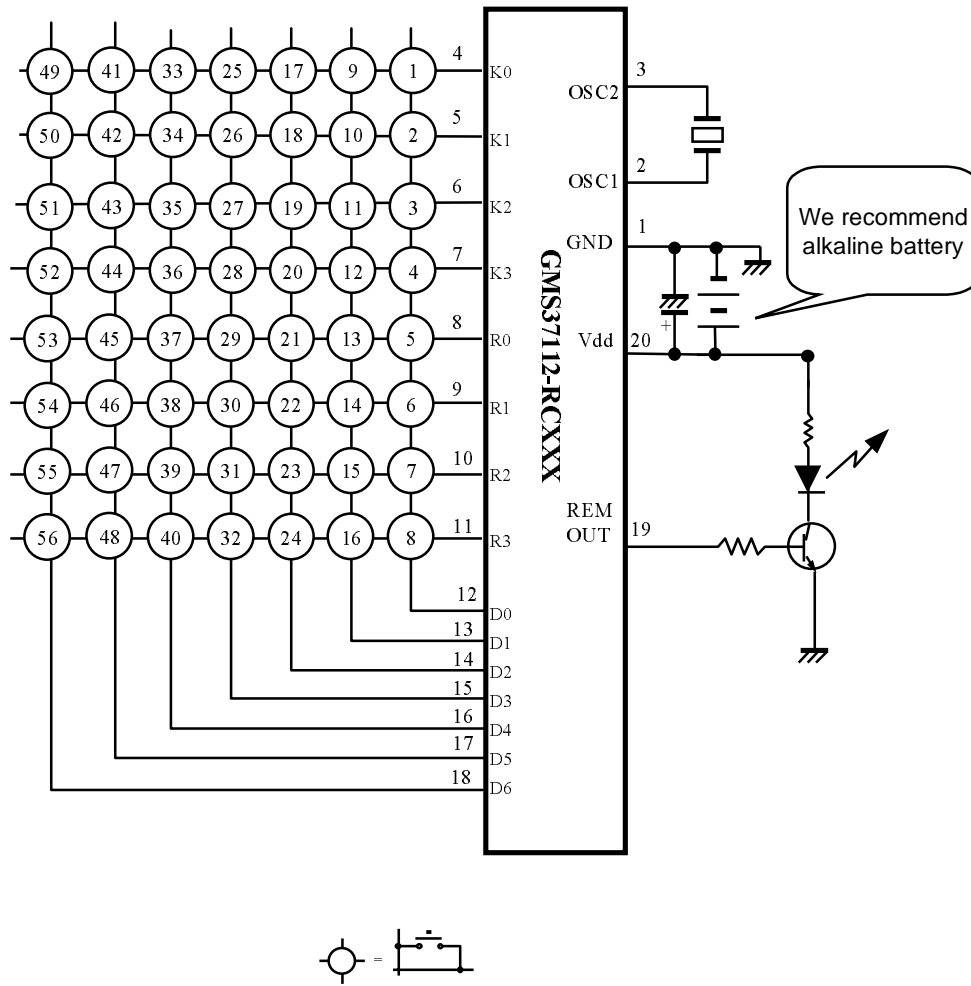

## Chapter 6. Application

---

Truth Table for example program

CUSTOM:04H

KEY NO.	DATA(H)	KEY NO.	DATA(H)
K01	00	K29	1C
K02	01	K30	1D
K03	02	K31	1E
K04	03	K32	1F
K05	04	K33	20
K06	05	K34	21
K07	06	K35	22
K08	07	K36	23
K09	08	K37	24
K10	09	K38	25
K11	0A	K39	26
K12	0B	K40	27
K13	0C	K41	28
K14	0D	K42	29
K15	0E	K43	2A
K16	0F	K44	2B
K17	10	K45	2C
K18	11	K46	2D
K19	12	K47	2E
K20	13	K48	2F
K21	14	K49	30
K22	15	K50	31
K23	16	K51	32
K24	17	K52	33
K25	18	K53	34
K26	19	K54	35
K27	1A	K55	36
K28	1B	K56	37

Output waveform of uPD6121G

A single pulse, modulated with 37.917KHz signal at 455KHz

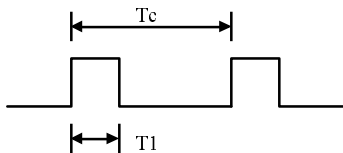

Carrier frequency

$$f_{CAR} = 1/Tc = f_{OSC}/12$$

$$\text{Duty ratio} = T1/Tc = 1/3$$

**- Configuration of Flame**

1st flame

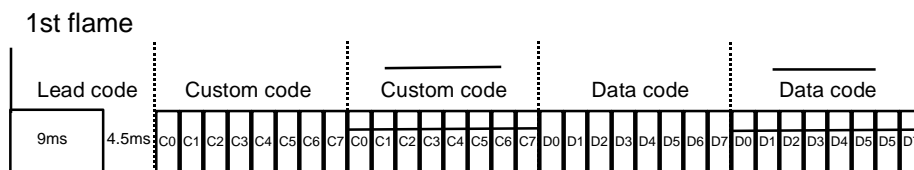

**- Repeat code**

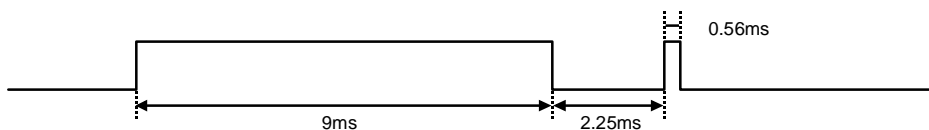

**- Bit Description**

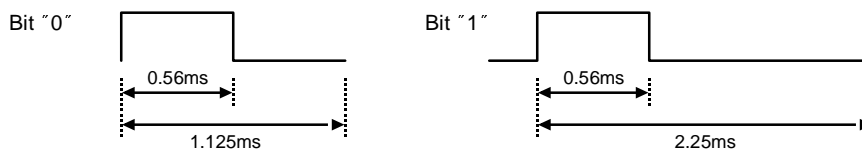

**- Flame Interval : Tf**

The transmitted waveform as long as a key is depressed

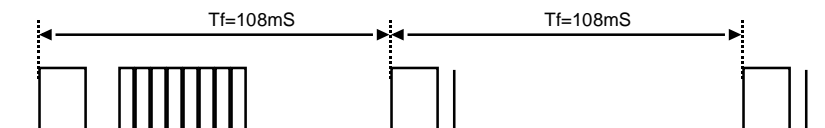

## Chapter 6. Application

---

### Example program - uPD6121G

```
        INCLUDE GMS30K.LIB
-----
;
; 99.9.8
; This program is example program for GMS37112 BY Hee Jin RYU
; The format is NEC format
-----
;
; RAM DEFINE
; X=0
COUNT EQU 00
NONE EQU 00 ; BIT DEFINE
FIRST EQU 01
REPEAT EQU 02
INDAT EQU 01
TOTLKY EQU 02
POINT EQU 03
STROBE EQU 04
CC6L EQU 06
CC6H EQU 07
CC7L EQU 08
CC7H EQU 09
NEWDTL EQU 10
NEWDTH EQU 11
KEYDTL EQU 12
KEYDTH EQU 13
OLDL EQU 14
OLDH EQU 15
-----
;
; PG 00
-----
RST LXI 0
LYI 15 ; RAM CLEAR
CLA LMIY 0
YNEI 15
BR CLA
LYI 15
SO
LYI 6 ; MAKE STROBE PORT LOW BEFORE STOP MODE
TORO RO
DY
BR TORO
CALL TIM10 ; FOR STABILIZATION PORT
STOP

MAIN LXI 0
LYI 15 ; ALL PORT HIGH FOR DECREASING CURRENT CONSUMPTION
SO
LYI COUNT
LMIY 0
KEY LYI 1
LPY
LYI COUNT
REM FIRST
REM NONE
SCAN LYI INDAT
LMIY 15
CLR LMIY 0
YNEI KEYDTL
BR CLR
CALL SCAN1
WDTR ; DON'T USE WDTR IN SUBROUTINE
LYI TOTLKY
MNEZ
BR KEY11
LYI COUNT
TM NONE
BR RST
SEM NONE
BR SCAN
KEY11 LYM
YNEI 1
BR MAIN
BL KEY12
```

```

DTCOM    CAL    COMPARE1
         ALEI    0
         BR     DTCOM1
         BL     TIM11
DTCOM1   DY
         CAL    COMPARE1
         ALEI    0
         BR     DATAC
         BR     RRTN
DATAC    LYI    0
         RTN
COMPARE1 LAM
         IY
         IY
         EORM
RRTN     RTN
    
```

```

NOP
BR      $          : END ADDRESS
-----
PG      01
-----
BR      $          : START ADDRESS
SCAN1   LYI    POINT
        LYM
        RO
        CALL   TIM30      : DELAY FOR KEY SCAN
        LAK
        ALEI   14
        CAL    KSAVE
        LAR
        ALEI   14
        CAL    RSAVE
        LYI    15
        SO
        LYI    POINT
        IM
        LMA
        ALEI   6
        BR     SCAN1
        RTN

KSAVE   NOP
        BR     SAVE
RSAVE   LYI    NEWDTL
        SEM    2
SAVE    LYI    INDAT
        LMAIY
        IM
        LMAIY
        LAM
        LYI    STROBE
        LMA
        RTN

COUN    LYI    COUNT
        TM     FIRST
        BR     KEY25
        SEM    FIRST

KEY26   LYI    NEWDTL
        CALL   DTMOVE
        LYI    2
        CALL   DLY65M
        BL     SCAN

KEY25   LYI    NEWDTL
        CALL   DTCOM
        YNEI   0
        BR     KEY26
    
```

## Chapter 6. Application

---

```

        LYI      KEYDTL
        CALL    DTCOM
        YNEI    0
        BR      KEY31

KEY32   LYI      KEYDTL
        CALL    DTMOVE
        BL      CUSREAD

KEY31   LYI      COUNT
        REM     REPEAT
        BR      KEY32

        NOP
        BR      $

;-----
;-----
        PG      02
;-----
;-----
        BR      $

KEY12   LYI      STROBE
        TM      0
        BR      LOOPA
        NOP
        BR      LOOPB

LOOPA   LYI      NEWDTL
        SEM     3

LOOPB   LYI      STROBE
        LAM
        LYI      NEWDTH

        ALEI    1
        BR      NTO
        ALEI    3
        BR      NT1
        ALEI    5
        BR      NT2
        LMIIY   3
        BR      CNVE

NTO     LMIIY    0
        CALL    TIM04
        BR      CNVE

NT1     LMIIY    1
        NOP
        BR      CNVE

NT2     LMIIY    2
        NOP

CNVE    LYI      INDAT
        LAM
        LYI      0
        ALEI    6
        BR      DWKEY
        ALEI    7
        BR      CON4      :3
        ALEI    10
        BR      DWKEY
        ALEI    11
        BR      CON3      :2
        ALEI    12
        BR      DWKEY
        ALEI    13
        BR      CON2      :1
        ALEI    14
        BR      CONV      :0

DWKEY   BL      MAIN
CON4    IY
        CALL    TIM03

CON3    IY
        CALL    TIM03

```



```

CON2      I Y
          NOP
CONV      LAY
          LYI      NEWDTL
          AM
          LMA
          BL      COUN

          NOP
          BR      $
-----
          PG      03
-----
          BR      $
CUSREAD  LYI      CCG L
          LMIIY   4
          LMIIY   0
          LMIIY   11
          LMIIY   15
CUSCOM   LYI      NEWDTL
          CALL    BAR      :Y=NEWDTL
          LYI      8
          SO      :HEAD
          LYI      9
          CALL    DLY65M
          CALL    TIM27
          LYI      8
          RO      :HEAD RO
          LYI      1
          CALL    DLY65M
          CALL    TIM29
          LYI      COUNT
          TM      REPEAT
          BR      HD1
FULCOD   LYI      1
          CALL    DLY65M

          CALL    TIM34
          LYI      POINT
          LMIIY   CCG L
          BL      T X

HD1      CALL    PULSE0
          LYI      10
          CAL     DLY65M
          CAL     DLY65M
          CAL     DLY65M
          WDTR
          CAL     DLY65M
          CAL     DLY65M
          CALL    TIM52
          BL      DDLY1

DLY65M   CALL    TIM63
DLY65M1  DY
          BR      DLY65M
          RTN

          I A      :UNUSED INSTRUCTION IS WRITTEN IN BLANK AREA
          DA
          LAY
          LYA
          LAZ
          XMA
          KNEZ
          RNEZ
          ALEM
          NOP

          BR      $
-----
          PG      04
-----

```

## Chapter 6. Application

---

```

PULSE      BR          $
PULSE0    CALL      TIM05
          LYI        8
          SO
          CALL      TIM41
          RO
          LYI        POINT
          LYM
          BL        TIM31

HGHOUST    CALL      TIM60
          BL        TIM25

TX         CAL       PULSE0
          TM        0
          CAL       HGHOUST
          CAL       PULSE
          TM        1
          CAL       HGHOUST
          CAL       PULSE
          TM        2
          CAL       HGHOUST
          CAL       PULSE
          TM        3
          CAL       HGHOUST
          LYI        POINT
          IM
          LMA
          ALBI      13
          BR        TX

ENDTX     CAL       PULSE0
          WDTR
          LYI        COUNT
          SEM        REPEAT
          LYI        9
          CALL      DLY65M
          CALL      TIM33
DDLTY1    LYI        0
          CALL      DLY65M
          CALL      DLY65M
          CALL      TIM54
          BL        KEY

bar       cal       bar1
bar1     im
          nega
COMPART   IY
          IY
          LMA
          DY
          RTN

DTMOVE    CAL       DTMOVE1
DTMOVE1   LAM
          BR        COMPART

          NOP
          BR        $
:-----:
          PG        05
:-----:
          BR        $
TIM65     NOP
TIM64     NOP
TIM63     NOP
TIM62     NOP
TIM61     NOP
TIM60     NOP
TIM59     NOP
TIM58     NOP

```

TIM57	NOP
TIM56	NOP
TIM55	NOP
TIM54	NOP
TIM53	NOP
TIM52	NOP
TIM51	NOP
TIM50	NOP
TIM49	NOP
TIM48	NOP
TIM47	NOP
TIM46	NOP
TIM45	NOP
TIM44	NOP
TIM43	NOP
TIM42	NOP
TIM41	NOP
TIM40	NOP
TIM39	NOP
TIM38	NOP
TIM37	NOP
TIM36	NOP
TIM35	NOP
TIM34	NOP
TIM33	NOP
TIM32	NOP
TIM31	NOP
TIM30	NOP
TIM29	NOP
TIM28	NOP
TIM27	NOP
TIM26	NOP
TIM25	NOP
TIM24	NOP
TIM23	NOP
TIM22	NOP
TIM21	NOP
TIM20	NOP
TIM19	NOP
TIM18	NOP
TIM17	NOP
TIM16	NOP
TIM15	NOP
TIM14	NOP
TIM13	NOP
TIM12	NOP
TIM11	NOP
TIM10	NOP
TIM09	NOP
TIM08	NOP
TIM07	NOP
TIM06	NOP
TIM05	NOP
TIM04	NOP
TIM03	RTN

## Chapter 6. Application

Reference to GMS36XXXT B/D

1. Attach resonator to X1
2. Connect base and collector at Q1
3. Connect PGND and TRGND with jumper at E

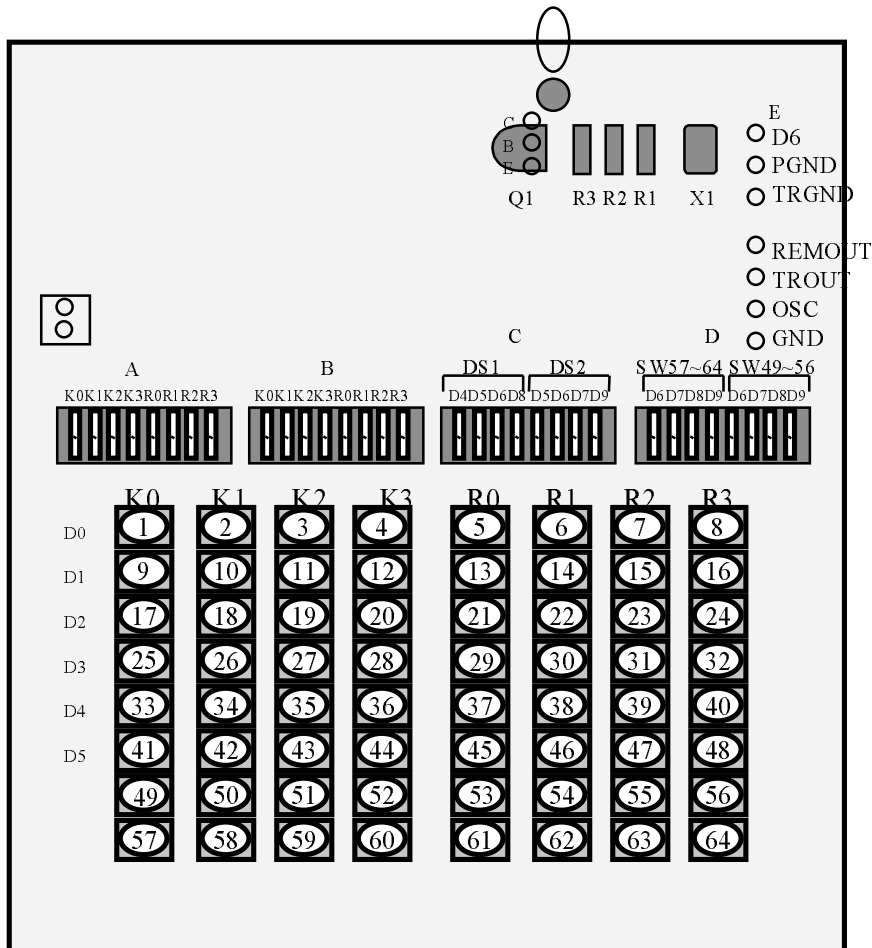

- \* DS1 is connected to A. If D6 switch is on among DS1 , A becomes D6 port.
- \* DS2 is connected to B. If D7 switch is on among DS2 , B becomes D7 port.
- \* If D6 switch among SW49~SW56 is on at D, the key 49~56 can be used as D6 port.
- \* If D7 switch among SW57~SW64 is on at D, the key 57~64 can be used as D7 port.
- \* note : the position of SW49~56 and SW57~64 in B/D is changed. The reference position is right.
- \* If you want to increase the remote controller valid distance, you try to disconnect R2 resistor and lessen R1 resistor.

Reference to GMS37XXXT B/D

1. Attach resonator to X1
2. Attach 2222A transistor to Q1
3. Connect PGND and D6 with jumper at E  
( remain D6 open state in case of GMS37140T)
4. Attach about 150Ω to R3.

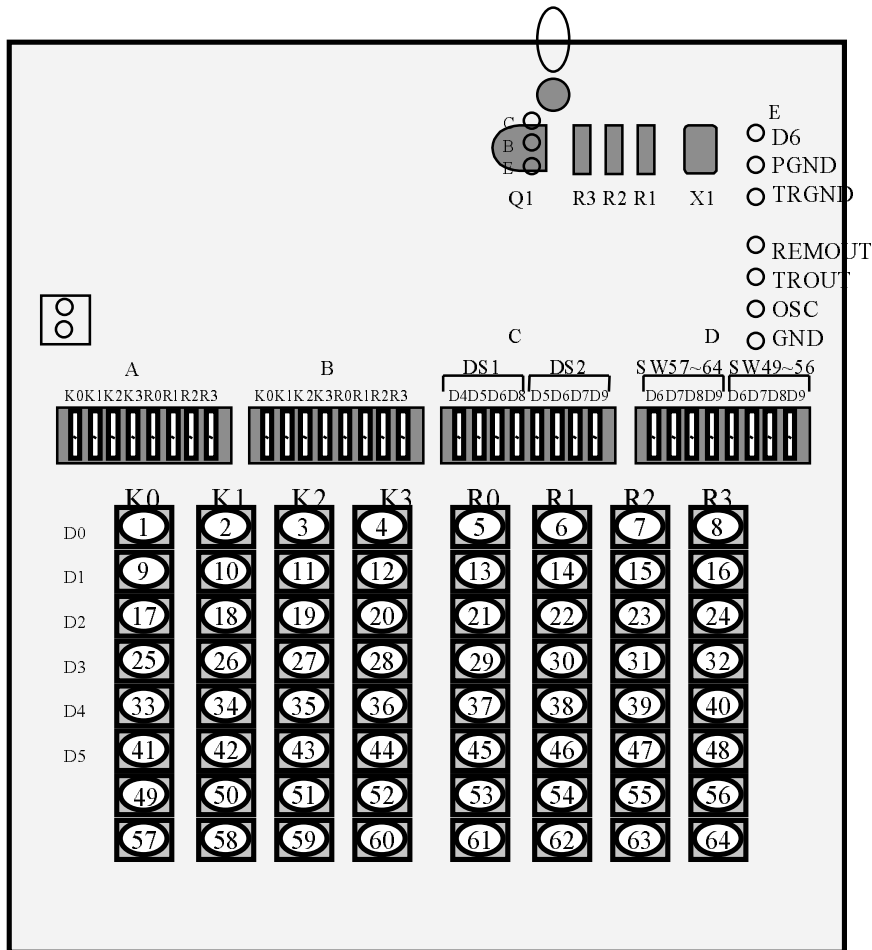

- \* DS1 is connected to A. If D6 switch is on among DS1 , A becomes D6 port.
- \* DS2 is connected to B. If D7 switch is on among DS2 , B becomes D7 port.
- \* If D6 switch among SW49~SW56 is on at D, the key 49~56 can be used as D6 port.
- \* If D7 switch among SW57~SW64 is on at D, the key 57~64 can be used as D7 port.
- \* note : the position of SW49~56 and SW57~64 in B/D is changed. The reference position is right.
- \* If you want to increase the remote controller valid distance, you try to disconnect R2 resistor and lessen R1 resistor.

---

<b>GMS36XXX</b>	<b>1</b>
<b>GMS37XXX</b>	<b>2</b>
<b>PACKAGE DIMENSIONS</b>	<b>3</b>
<b>FUNCTIONAL DESCRIPTION</b>	<b>4</b>
<b>INSTRUCTION</b>	<b>5</b>
<b>APPLICATION</b>	<b>6</b>
<b>GMS36XXXT</b>	<b>7</b>
<b>GMS37XXXT</b>	<b>8</b>
<b>EPROM</b>	<b>9</b>

---

## CHAPTER 7. GMS36XXXT

### Description

The GMS36XXXT series are remote control transmitter which uses CMOS technology and the EPROM version.

This enables transmission code outputs of different configurations, multiple custom code output and double push key output for easy fabrication.

The GMS36XXXT series are suitable for remote control of TV, VCR, FANS, Air-conditioners, Audio Equipment, Toys, Games etc.

### Features

- Program memory : 1,024 bytes for GMS36/004T/112T/140T
- Data memory :  $32 \times 4$  bits
- 43 types of instruction set
- 3 levels of subroutine nesting
- Operating frequency : 300kHz ~ 1MHz at kHz version  
2.4MHz ~ 4MHz at MHz version
- Instruction cycle :  $f_{OSC}/6$  at kHz version  
 $f_{OSC}/48$  at MHz version
- CMOS process (Single 3.0V power supply)
- Stop mode (Through internal instruction)
- Released stop mode by key input
- Built in Power-on Reset circuit
- Built in Low Voltage Detection circuit
- Built in capacitor for ceramic oscillation circuit at kHz version
- Built in a watch dog timer (WDT)
- Built in transistor for I.R LED Drive :  $I_{OL} = 190\text{mA}$  at  $V_{DD} = 3\text{V}$  and  $V_O = 0.3\text{V}$
- Low operating voltage: 2.2 ~ 3.6V (at 300kHz ~ 4MHz)

**Table 7-1 GMS36XXXT series members**

Series	GMS36004T	GMS36112T	GMS36140T
Program memory	1,024	1,024	1,024
Data memory	$32 \times 4$	$32 \times 4$	$32 \times 4$
I/O ports	-	4	4
Input ports	4	4	4
Output ports	6 (D0~D5)	6 (D0~D5)	10 (D0~D9)
Package	16DIP/SOP	20DIP/SOP/SSOP	24Skinny DIP/SOP

Pin Description

Pin	I/O	Function
VDD	-	Connected to 2.2~ 3.6V power supply
GND	-	Connected to 0V power supply.
K0 ~ K3	Input	4-bit input port with built in pull-up resistor. STOP mode is released by "L" input of each pin. Especially, K3 is the input pin for VPP. For programming K3 pin receives 12.5V(programming voltage).
D0 ~ D9	Output	Each can be set and reset independently. The output is the structure of N-channel-open-drain.
R0 ~ R3	I/O	4-bit I/O port. (Input mode is set only when each of them output "H".) In outputting, each can be set and reset independently(or at once.) The output is in the form of C-MOS. STOP mode is released by "L" input of each pin.
OSC1	Input	Oscillator input. Input to the oscillator circuit and connection point for ceramic resonator. Internal capacitors available at kHz version. A feedback resistor is internally connected between this pin and OSC2.
OSC2	Output	Connect a resonator between this pin and OSC1.
REMOUT	Output	High current output port driving I.R. LED. The output is in the form of N-channel-open-drain.
PGND	-	High current Tr. ground pin. (connected to GND) High current output Tr. is connected between this pin and REMOUT.



## STOP Operation

Stop mode can be achieved by STOP instructions.

In stop mode :

1. Oscillator is stopped, the operating current is low.
2. Watch dog timer is reset, D0~D3 output is "L" and REMOUT output is "H" (Output Tr. is off.)
3. Part other than WDT, D0~D3 output and REMOUT output have a value before come into stop mode.

Stop mode is released when one of K or R input is going to "L".

1. State of D0~D3 output and REMOUT output is return to state of before stop mode is achieved.
2. After  $2^{10} \times$  System clock time for stable oscillating, first instruction start to operate.
3. In return to normal operation, WDT is counted from zero again.

But, at executing stop instruction, if one of K or R input is chosen to "L", stop instruction is same to NOP instruction.

## Electrical Characteristics

Absolute maximum ratings (Ta = 25°C)

Parameter	Symbol	Max. rating	Unit
Supply Voltage	V <sub>DD</sub>	-0.3 ~ 5.0	V
Programming Voltage	V <sub>PP</sub>	-0.3 ~ 13.5	V
Power dissipation	P <sub>D</sub>	700 *	mW
Storage temperature range	T <sub>stg</sub>	-55 ~ 125	°C
Input voltage	V <sub>IN</sub>	-0.3 ~ V <sub>DD</sub> +0.3	V
Output voltage	V <sub>OUT</sub>	-0.3 ~ V <sub>DD</sub> +0.3	V

\* Thermal derating above 25°C : 6mW per degree °C rise in temperature.

## Recommended operating condition

Parameter	Symbol	Condition	Rating	Unit
Supply Voltage	V <sub>DD</sub>	300kHz ~ 4MHz	2.2 ~ 3.6	V
Operating temperature	T <sub>opr</sub>	-	-20 ~ +70	°C

Electrical characteristics (Ta=25°C, V<sub>DD</sub>= 3V)

Parameter	Symbol	Limits			Unit	Condition	
		Min.	Typ.	Max.			
Input H current	I <sub>IH</sub>	-	-	1	uA	V <sub>I</sub> =V <sub>DD</sub>	
K Pull-up Resistance	R <sub>PU1</sub>	70	140	300	kΩ	V <sub>I</sub> =GND	
R Pull-up Resistance	R <sub>PU2</sub>	70	140	300	kΩ	V <sub>I</sub> =GND, Output off	
Feedback Resistance	R <sub>FD</sub>	0.3	1.0	3.0	MΩ	V <sub>OSC1</sub> =GND, V <sub>OSC2</sub> =V <sub>DD</sub>	
K, R input H voltage	V <sub>IH1</sub>	2.1	-	-	V	-	
K, R input L voltage	V <sub>IL1</sub>	-	-	0.9	V	-	
D, R output L voltage	V <sub>OL2</sub> <sup>*1</sup>	-	0.15	0.4	V	I <sub>OL2</sub> =3mA	
OSC2 output L voltage	V <sub>OL3</sub>	-	0.4	0.9	V	I <sub>OL3</sub> =40uA (455kHz) = 150uA (4MHz)	
OSC2 output H voltage	V <sub>OH3</sub>	2.1	2.5	-	V	I <sub>OH3</sub> = -40uA (455kHz) = -150uA (4MHz)	
REMOUT output L current	I <sub>OL1</sub> <sup>*2</sup>	150	190	230	mA	V <sub>OL1</sub> =0.3V	
		200	250	300	mA	V <sub>OL1</sub> =0.4V	
REMOUT leakage current	I <sub>OLK1</sub>	-	-	1	uA	V <sub>OUT</sub> =V <sub>DD</sub> , Output off	
D, R output leakage current	I <sub>OLK2</sub>	-	-	1	uA	V <sub>OUT</sub> =V <sub>DD</sub> , Output off	
Current on STOP mode	I <sub>STP</sub>	-	-	1	uA	At STOP mode	
Operating supply current 1	I <sub>DD1</sub> <sup>*3</sup>	-	0.8	1.5	mA	f <sub>OSC</sub> =455KHz	
Operating supply current 2	I <sub>DD2</sub> <sup>*3</sup>	-	1.0	3.0	mA	f <sub>OSC</sub> =4MHz	
System clock frequency	f <sub>OSC</sub> /6	f <sub>OSC</sub>	300	-	1000	kHz	kHz version
	f <sub>OSC</sub> /48	f <sub>OSC</sub>	2.4	-	4	MHz	MHz version

\*1 Refer to < Fig.7-1 I<sub>OL2</sub> vs. V<sub>OL2</sub> Graph >\*2 Refer to < Fig.7-2 I<sub>OL1</sub> vs. V<sub>OL1</sub> Graph >\*3 I<sub>DD1</sub>, I<sub>DD2</sub>, is measured at RESET mode.

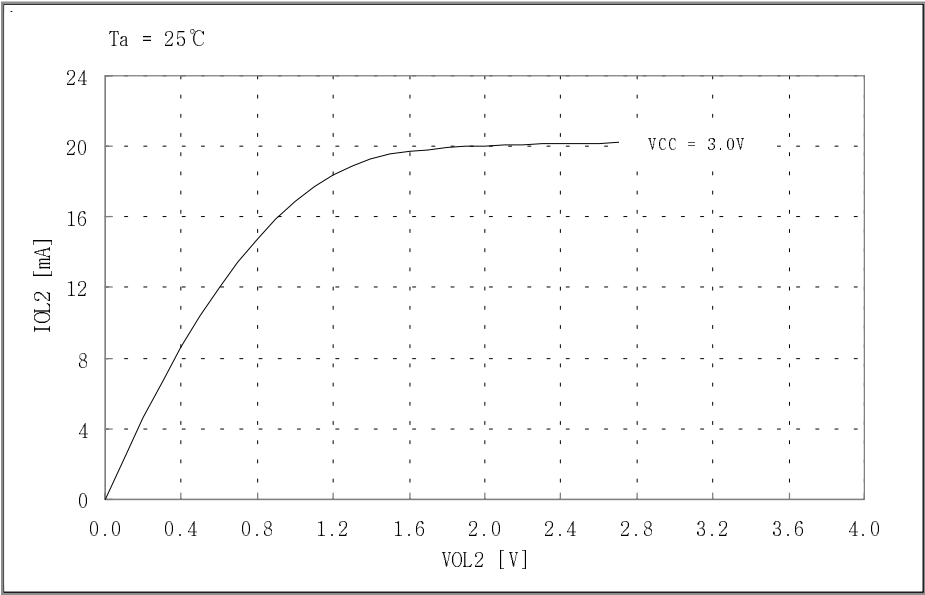

Fig 7-1.  $I_{OL2}$  vs.  $V_{OL2}$  Graph. ( D, R Port )

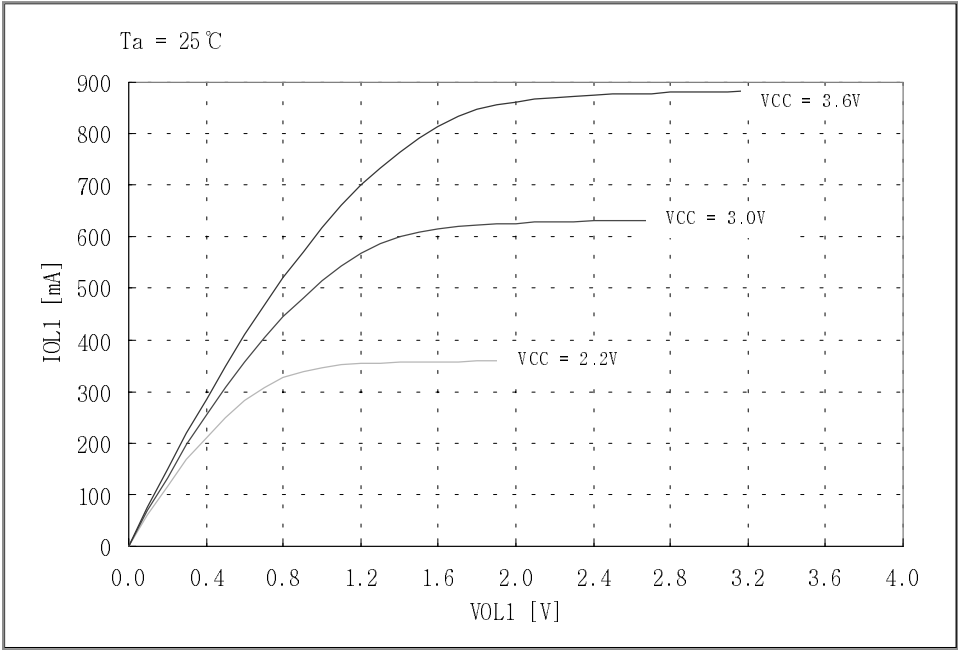

Fig 7-2.  $I_{OL1}$  vs.  $V_{OL1}$  Graph. ( REMOUT port )

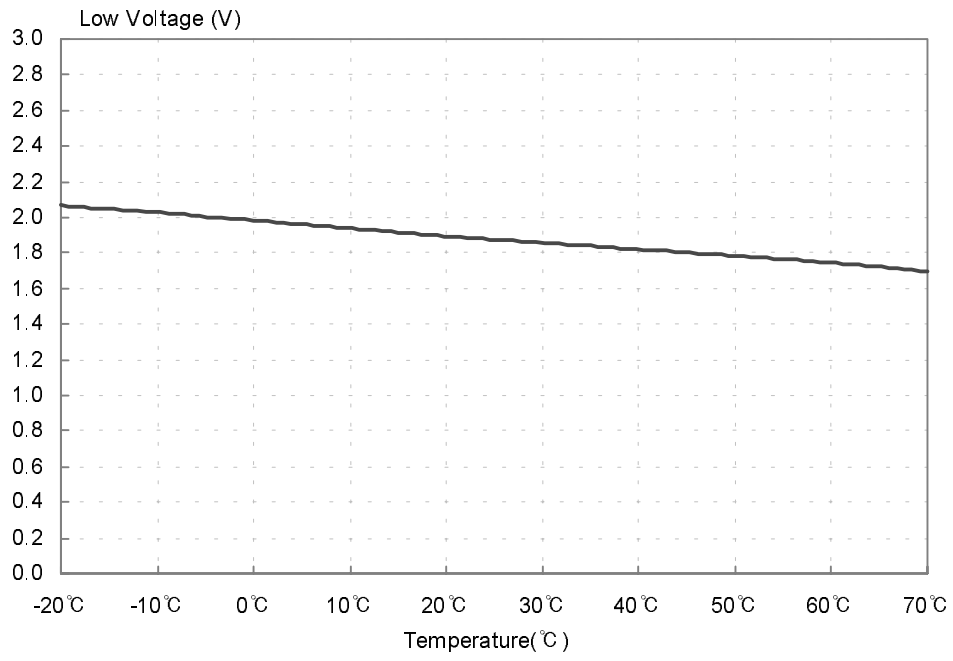

Fig 7-3. Low Voltage vs Temperature

---

<b>GMS36XXX</b>	<b>1</b>
<b>GMS37XXX</b>	<b>2</b>
<b>PACKAGE DIMENSIONS</b>	<b>3</b>
<b>FUNCTIONAL DESCRIPTION</b>	<b>4</b>
<b>INSTRUCTION</b>	<b>5</b>
<b>APPLICATION</b>	<b>6</b>
<b>GMS36XXXT</b>	<b>7</b>
<b>GMS37XXXT</b>	<b>8</b>
<b>EPROM</b>	<b>9</b>

---

## CHAPTER 8. GMS37XXXT

### Description

The GMS37XXXT series are remote control transmitter which uses CMOS technology and the EPROM version.

This enables transmission code outputs of different configurations, multiple custom code output, and double push key output for easy fabrication.

The GMS37XXXT series are suitable for remote control of TV, VCR, FANS, Air-conditioners, Audio Equipment, Toys, Games etc.

It is possible to structure the 8 x 7 key matrix for GMS37112T, and the 4 x 7 key matrix for GMS37004T.

### Features

- Program memory : 1,024 bytes for GMS37004T/112T/140T
- Data memory : 32 × 4 bits
- 43 types of instruction set
- 3 levels of subroutine nesting
- Operating frequency : 300kHz ~ 1MHz at kHz version  
2.4MHz ~ 4MHz at MHz version
- Instruction cycle :  $f_{osc}/6$  at kHz version  
 $f_{osc}/48$  at MHz version
- CMOS process (Single 3.0V power supply)
- Stop mode (Through internal instruction)
- Released stop mode by key input
- Built in Power-on Reset circuit
- Built in Low Voltage Detection circuit
- Built in capacitor for ceramic oscillation circuit at kHz version
- Built in a watch dog timer (WDT)
- Low operating voltage : 2.2 ~ 3.6V (at 300kHz ~ 4MHz)

**Table 8-1 GMS37XXXT series members**

Series	GMS37004T	GMS37112T	GMS37140T
Program memory	1,024	1,024	1,024
Data memory	32 × 4	32 × 4	32 × 4
I/O ports	-	4	4
Input ports	4	4	4
Output ports	7 (D0~D6)	7 (D0~D6)	10 (D0~D9)
Package	16DIP/SOP	20DIP/SOP/SSOP	24Skinny DIP/SOP

## Pin Description

<b>Pin</b>	<b>I/O</b>	<b>Function</b>
VDD	-	Connected to 2.2~ 3.6V power supply
GND	-	Connected to 0V power supply.
K0 ~ K3	Input	4-bit input port with built in pull-up resistor. STOP mode is released by "L" input of each pin. Especially, K3 is the input pin for VPP. For programming K3 pin receives 12.5V(programming voltage).
D0 ~ D9	Output	Each can be set and reset independently. The output is the structure of N-channel-open-drain.
R0 ~ R3	I/O	4-bit I/O port. (Input mode is set only when each of them output "H".) In outputting, each can be set and reset independently(or at once.) The output is in the form of C-MOS. STOP mode is released by "L" input of each pin.
OSC1	Input	Oscillator input. Input to the oscillator circuit and connection point for ceramic resonator. Internal capacitors available at kHz version. A feedback resistor is internally connected between this pin and OSC2.
OSC2	Output	Connect a resonator between this pin and OSC1.
REMOUT	Output	High current output port The output is in the form of C-MOS. The state of large current on is " H "



## STOP Operation

Stop mode can be achieved by STOP instructions.

In stop mode :

1. Oscillator is stopped, the operating current is low.
2. Watch dog timer is reset, D0~D3 output is "L" and REMOUT output is "L"
3. Part other than WDT, D0~D3 output and REMOUT output have a value before come into stop mode.

Stop mode is released when one of K or R input is going to "L".

1. State of D0~D3 output and REMOUT output is return to state of before stop mode is achieved.
2. After  $2^{10} \times$  System clock time for stable oscillating, first instruction start to operate.
3. In return to normal operation, WDT is counted from zero again.

But, at executing stop instruction, if one of K or R input is chosen to "L", stop instruction is same to NOP instruction.

## Electrical Characteristics

Absolute maximum ratings (Ta = 25°C)

Parameter	Symbol	Max. rating	Unit
Supply Voltage	V <sub>DD</sub>	-0.3 ~ 5.0	V
Programming Voltage	V <sub>PP</sub>	-0.3 ~ 13.5	V
Power dissipation	P <sub>D</sub>	700 *	mW
Storage temperature range	T <sub>stg</sub>	-55 ~ 125	°C
Input voltage	V <sub>IN</sub>	-0.3 ~ V <sub>DD</sub> +0.3	V
Output voltage	V <sub>OUT</sub>	-0.3 ~ V <sub>DD</sub> +0.3	V

\* Thermal derating above 25°C : 6mW per degree °C rise in temperature.

## Recommended operating condition

Parameter	Symbol	Condition	Rating	Unit
Supply Voltage	V <sub>DD</sub>	300kHz ~ 4MHz	2.2 ~ 3.6	V
Operating temperature	T <sub>opr</sub>	-	-20 ~ +70	°C

Electrical characteristics (Ta=25°C, V<sub>DD</sub>= 3V)

Parameter	Symbol	Limits			Unit	Condition	
		Min.	Typ.	Max.			
Input H current	I <sub>IH</sub>	-	-	1	uA	V <sub>I</sub> =V <sub>DD</sub>	
K Pull-up Resistance	R <sub>PU1</sub>	70	140	300	kΩ	V <sub>I</sub> =GND	
R Pull-up Resistance	R <sub>PU2</sub>	70	140	300	kΩ	V <sub>I</sub> =GND, Output off	
Feedback Resistance	R <sub>FD</sub>	0.3	1.0	3.0	MΩ	V <sub>OSC1</sub> =GND, V <sub>OSC2</sub> =V <sub>DD</sub>	
K, R input H voltage	V <sub>IH1</sub>	2.1	-	-	V	-	
K, R input L voltage	V <sub>IL1</sub>	-	-	0.9	V	-	
D, R output L voltage	V <sub>OL2</sub> <sup>*1</sup>	-	0.15	0.4	V	I <sub>OL2</sub> =3mA	
OSC2 output L voltage	V <sub>OL3</sub>	-	0.4	0.9	V	I <sub>OL3</sub> =40uA (455kHz) =150uA (4MHz)	
OSC2 output H voltage	V <sub>OH3</sub>	2.1	2.5	-	V	I <sub>OH3</sub> = -40uA (455kHz) = -150uA (4MHz)	
REMOOUT output L current	I <sub>OL1</sub> <sup>*2</sup>	1	2.2	4	mA	V <sub>OL1</sub> =0.4V	
REMOOUT output H current	I <sub>OH1</sub> <sup>*3</sup>	-5	-15	-30	mA	V <sub>OH1</sub> =2V	
D, R output leakage current	I <sub>OLK2</sub>	-	-	1	uA	V <sub>OUT</sub> =V <sub>DD</sub> , Output off	
Current on STOP mode	I <sub>STP</sub>	-	-	1	uA	At STOP mode	
Operating supply current 1	I <sub>DD1</sub> <sup>*4</sup>	-	0.8	1.5	mA	f <sub>OSC</sub> =455KHz	
Operating supply current 2	I <sub>DD2</sub> <sup>*4</sup>	-	1.0	3.0	mA	f <sub>OSC</sub> =4MHz	
System clock frequency	f <sub>OSC</sub> /6	f <sub>OSC</sub>	300	-	1000	kHz	kHz version
	f <sub>OSC</sub> /48	f <sub>OSC</sub>	2.4	-	4	MHz	MHz version

\*1 Refer to Fig.8-1 < I<sub>OL2</sub> vs. V<sub>OL2</sub> Graph>\*2 Refer to Fig.8-2 < I<sub>OL1</sub> vs. V<sub>OL1</sub> Graph>\*3 Refer to Fig.8-3 < I<sub>OH1</sub> vs. V<sub>OH1</sub> Graph>\*4 I<sub>DD1</sub>, I<sub>DD2</sub> is measured at RESET mode.

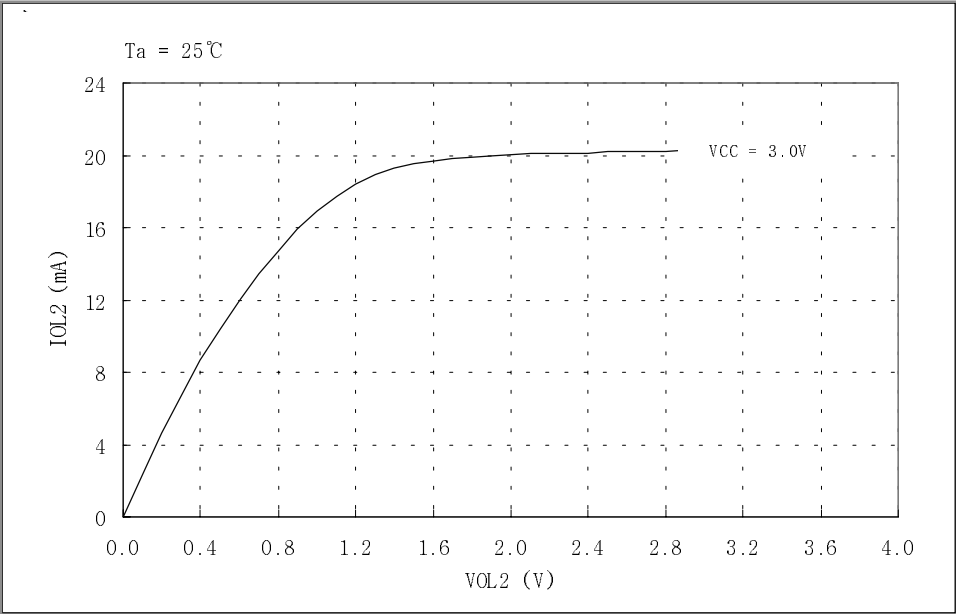

Fig 8-1. IOL2 vs. VOL2 Graph. ( D, R, OD6 Port )

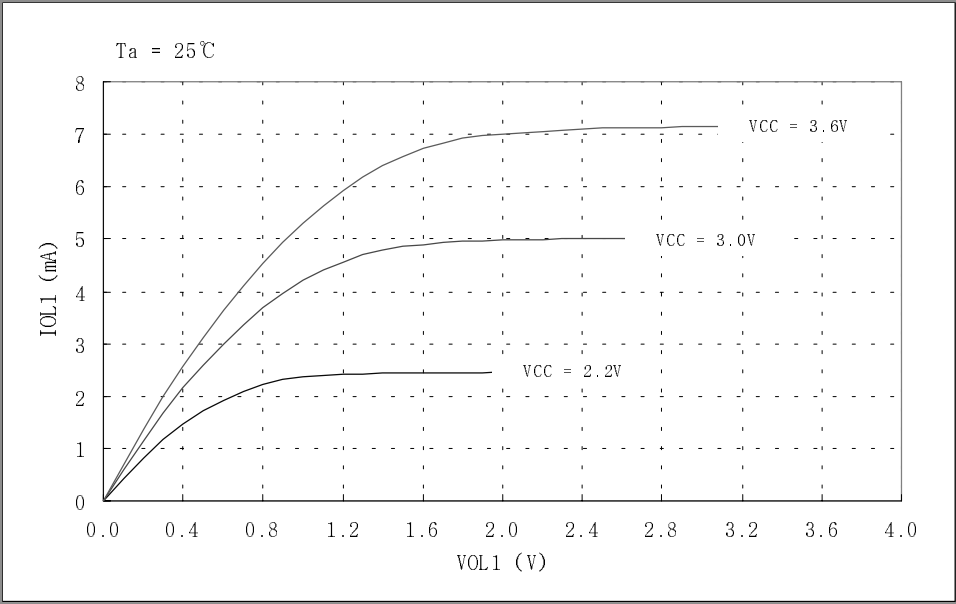

Fig 8-2. IOL1 vs VOL1 Graph (REMOUT Port)

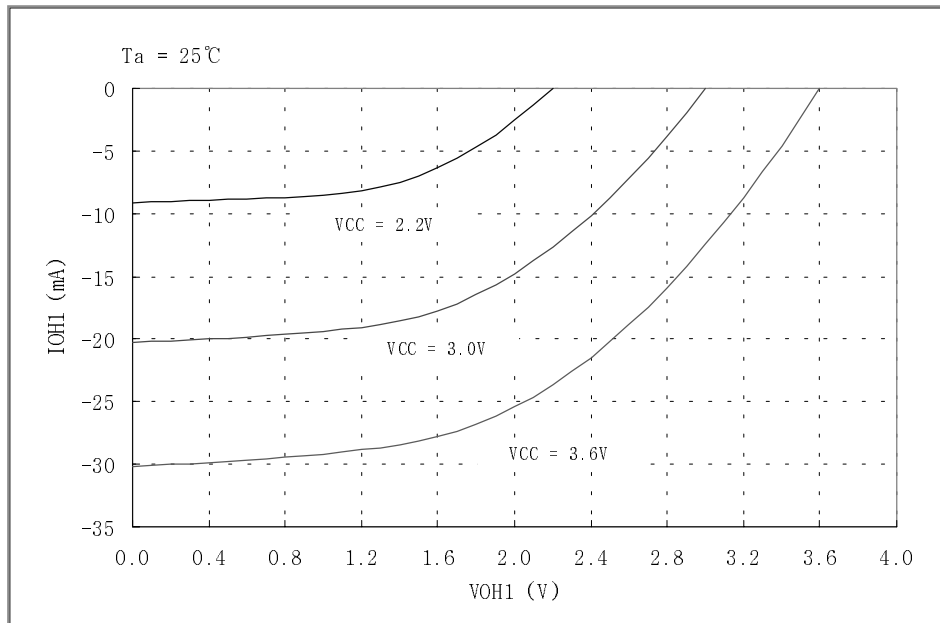

Fig 8-3.  $I_{OH1}$  vs  $V_{OH1}$  Graph (REMOUT Port)

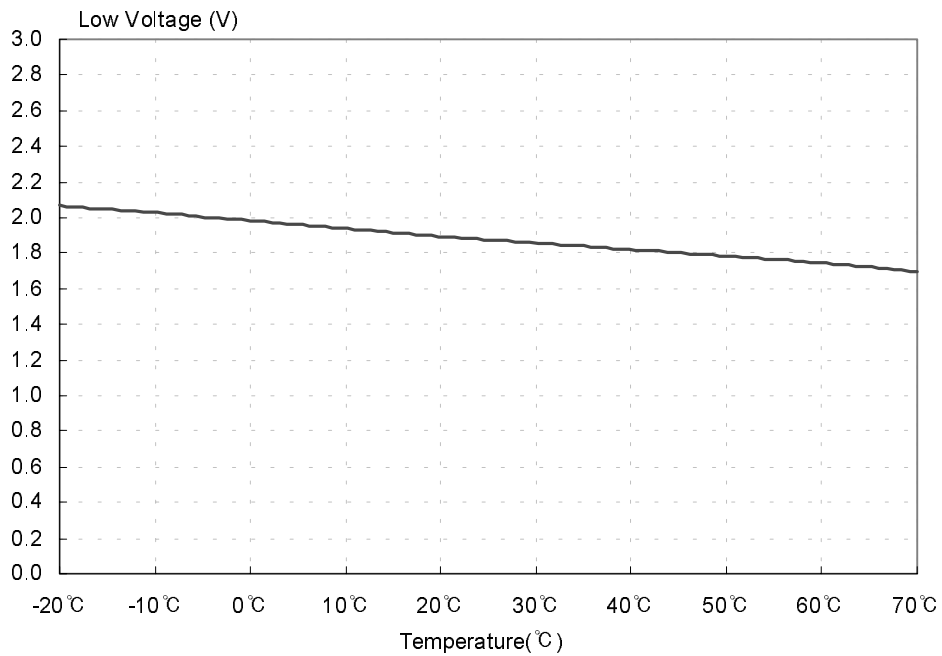
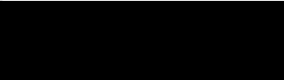

Fig 8-4. Low Voltage vs Temperature

---

<b>GMS36XXX</b>	<b>1</b>
<b>GMS37XXX</b>	<b>2</b>
<b>PACKAGE DIMENSIONS</b>	<b>3</b>
<b>FUNCTIONAL DESCRIPTION</b>	<b>4</b>
<b>INSTRUCTION</b>	<b>5</b>
<b>APPLICATION</b>	<b>6</b>
<b>GMS36XXXT</b>	<b>7</b>
<b>GMS37XXXT</b>	<b>8</b>
<b>EPROM</b>	<b>9</b>



---

## CHAPTER 9. EPROM

### MODE Define

Item	Device operation	Mode setting			
<b>User mode</b>	Exact User pgm	K3~ K0 = 0 ~ 3V		Vcc=3V	
<b>EPROM read mode</b>	Address in, Data out	K3 =12.5V	K2 = Vcc	K1~0=01/10 Vcc=5.5V	
<b>1Byte PGM Write &amp; Verify</b>	Address in, Data in Data out			K1~0=01/10 Vcc=5.5V	
<b>Lock bit Write mode</b>	Lock bit write			K1~0=01/00	Vcc=5.5V, (Default : unlock)
<b>Lock bit Read mode</b>	Lock bit out (to D5 port)			K1~0=01/01	
<b>Reset mode</b>	System reset before all test	K2 = 0V	-	-	

\* Mode setting (K1~0=01/10) means the serial input by 2bits.

### Port Define for GMS36XXXT

Eprom Mode ⇔ User Mode

24PIN (GMS36140T)

User Mode ⇔ Eprom Mode

Port Name	User Mode	EPROM Mode
VDD,GND	Power	Power
PGND	Pgnd(=0V)	-
OSC1,2	Clock	Clock
Remout	Remout	-
K0	K0(Iinput)	Mode setting Read / Write Control Address / Data Control
K1	K1(Iinput)	
K2	K2(Iinput)	Reset
K3	K3(Iinput)	VPP (12.5V)
D0	D0(Output)	Ad0 Ad5 Da0 Da4
D1	D1(Output)	Ad1 Ad6 Da1 Da5
D2	D2(Output)	Ad2 Ad7 Da2 Da6
D3	D3(Output)	Ad3 Ad8 Da3 Da7
D4	D4(Output)	Ad4 Ad9
D5	D5(Output)	Lock data output
D6	D6(Output)	-
D7	D7(Output)	-
D8	D8(Output)	-
D9	D9(Output)	-
R0	R0(I/O)	-
R1	R1(I/O)	-
R2	R2(I/O)	-
R3	R3(I/O)	-

Eprom Mode ⇔ User Mode

20PIN (GMS36112T)

Eprom Mode ⇔ User Mode

16PIN (GMS36004T)

## Chapter 9. EPROM

### Port Define for GMS37XXXXT

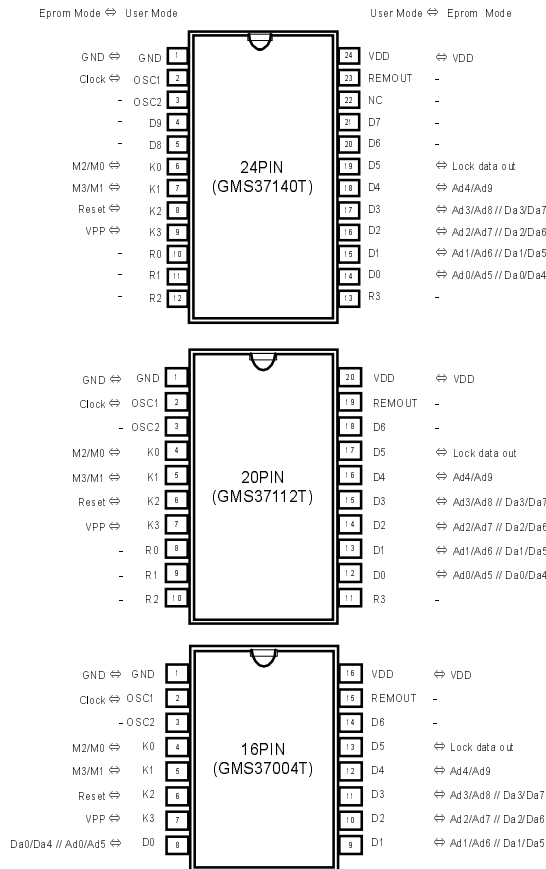

Port Name	User Mode	EPROM Mode			
VDD,GND	Power	Power			
OSC1,2	Clock	Clock			
K0	K0(Input)	Mode setting Read / Write Control Address / Data Control			
K1	K1(Input)				
K2	K2(Input)	Reset			
K3	K3(Input)	VPP (12.5V)			
D0	D0(Output)	Ad0	Ad5	Da0	Da4
D1	D1(Output)	Ad1	Ad6	Da1	Da5
D2	D2(Output)	Ad2	Ad7	Da2	Da6
D3	D3(Output)	Ad3	Ad8	Da3	Da7
D4	D4(Output)	Ad4	Ad9		
D5	D5(Output)	Lock data output			
D6	D6(Output)	-			
D7	D7(Output)	-			
D8	D8(Output)	-			
D9	D9(Output)	-			
NC	-	-			
Remout	Remout	-			
R0	R0(I/O)	-			
R1	R1(I/O)	-			
R2	R2(I/O)	-			
R3	R3(I/O)	-			



AC / DC Timing Requirements for Program / Read Mode ( $T_a = 25^\circ\text{C}$  )

Name	Symbol	Units	Min.	Typ.	Max.	비 고
OSC1 Clock Period	Tp	us	1.8	2	3	at KHZ Version
		ns	200	250	400	at MHZ Version
Programming Supply Current	$I_{VPP}$	mA	-	-	50	
Supply Current in EPROM Mode	$I_{VDDP}$	mA	-	-	20	
VPP Level during Programming	$V_{IHP}$	V	12.5	12.75	13	
VDD Level in Program Mode	$V_{DD1H}$	V	5.0	5.5	6.0	
VDD Level in Read Mode	$V_{DD2H}$	V	-	3, 5.5	-	
K2 ~ K0 High Level in EPROM Mode	$V_{IHK}$	V	$V_{DD} \times 0.8$	-	-	
K2 ~ K0 Low Level in EPROM Mode	$V_{ILK}$	V	-	-	$V_{DD} \times 0.2$	
D4~D0 High Level in EPROM Mode	$V_{IHD}$	V	$V_{DD} \times 0.9$	-	-	
D4~D0 High Level in EPROM Mode	$V_{ILD}$	V	-	-	$V_{DD} \times 0.1$	
VDD Sturation Time	$T_{VDDS}$	ms	1	-	-	
VPP Setup Time	$T_{VPPR}$	ms	-	-	1	
VPP Saturation Time	$T_{VPPS}$	ms	1	-	-	System reset 수행
K2 Input Delay time	$T_{K2D}$	ns	$T_p / 8$	$T_p / 4$	$T_p / 2$	
K2 Input Setup time	$T_{K2S}$	ns	$T_p / 8$	$T_p / 4$	$T_p / 2$	
K1~K0 Mode input Setup time	$T_{MODE}$	us	$T_p \times 0.5$	$T_p \times 0.8$	$T_p \times 1.0$	
D4~D0 Data input Hold Time	$T_{HLD}$	us	-	$T_p$	-	
K1~K0 Data input Setup Time	$T_{DLY1}$	ns	$T_p \times 0.05$	$T_p \times 0.08$	$T_p \times 0.1$	
D4~D0 Data input Setup Time	$T_{DLY2}$	ns	$T_p \times 0.05$	$T_p \times 0.1$	$T_p \times 0.15$	
D4~D0 Output Strobing Time	$T_{STB1}$	ns	$T_p \times 0.2$	$T_p \times 0.3$	$T_p \times 0.4$	
D5 Output Strobing Time	$T_{STB2}$	us	$T_p \times 3.0$	$T_p \times 6.0$	$T_p \times 12.0$	At Lock Read Only

## Chapter 9. EPROM

Program / Verify Timing Diagrams In kHz Version.

### 1) EPROM Write & Verify Mode (1Byte)

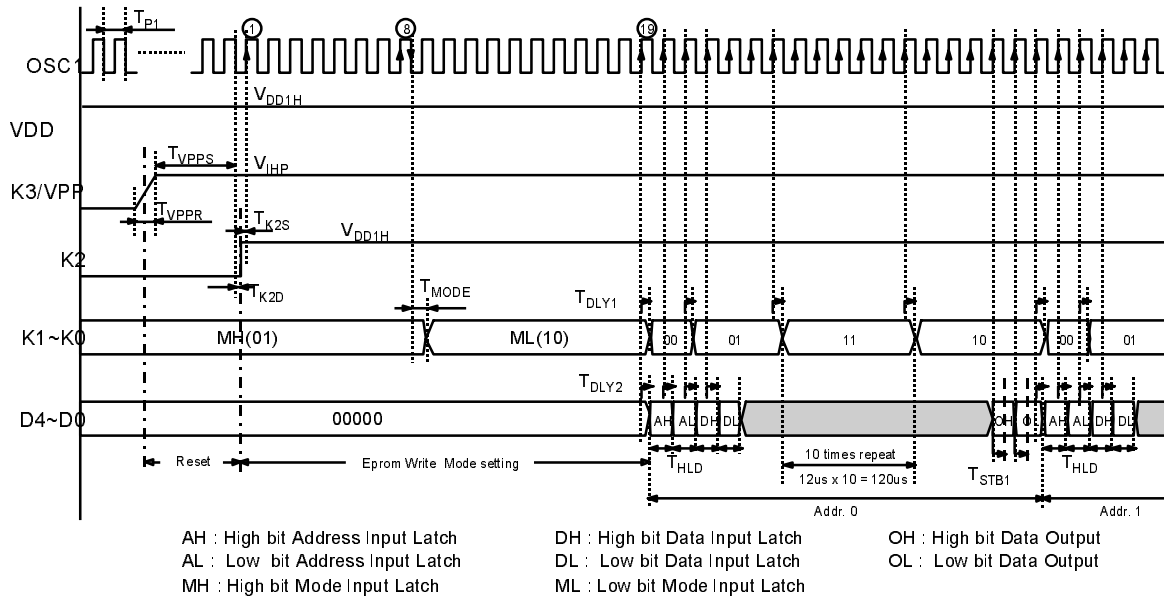

#. Note :

1. Internal system is reset at  $V_{PP} = 12.5V$  and  $K2 = \text{'Low'}$
2. The reset release ( $K2 = \text{'High'}$ ) must be set within  $OSC1 = \text{'Low'}$  state.  
(From this time, OSC1 clock is counted.)
3. The Data will be inputted from the 19th rising edge of OSC1.
4. If not written during 10 times repeats (120us), repeat the 5 times until all is written.
5. For device verify. If you set Lock bit, output data is always  $\text{'0F'}$ h.

2) EPROM Read Mode (1Byte)

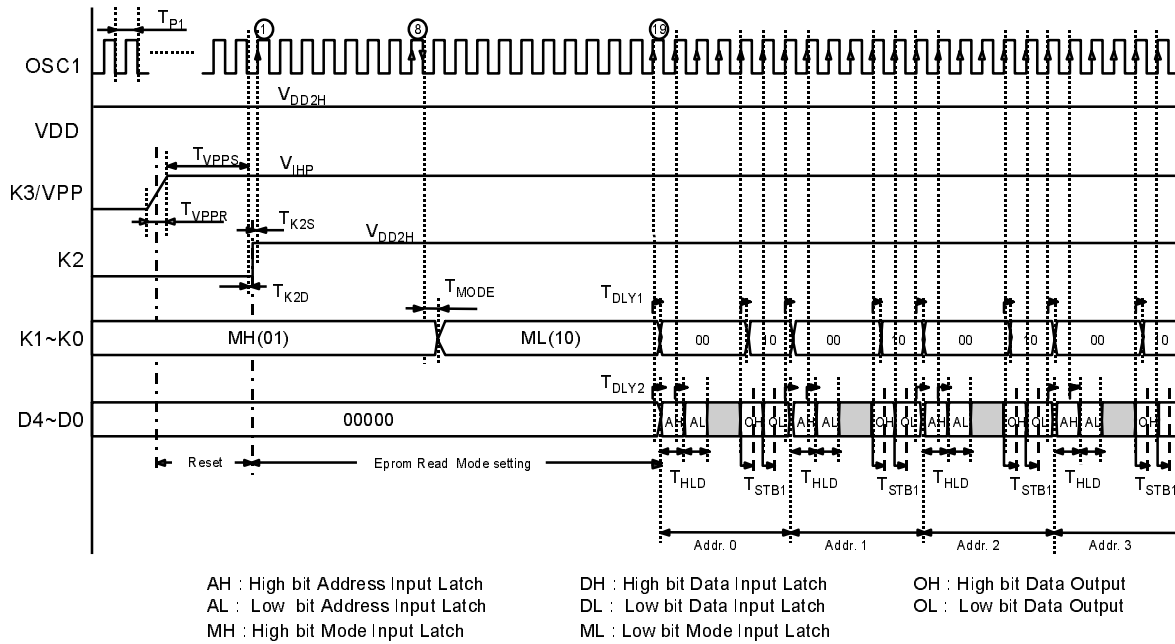

#. Note :

1. Internal system is reset at  $V_{PP} = 12.5V$  and  $K2 = \text{'Low'}$
2. The reset release ( $K2 = \text{'High'}$ ) must be set within  $OSC1 = \text{'Low'}$  state.  
 (From this time,  $OSC1$  clock is counted.)
3. The Data will be inputted from the 19th rising edge of  $OSC1$ .
4. For device verify. If you set Lock bit, output data is always  $\text{'0F'h}$ .

3) Lock Bit Write Mode

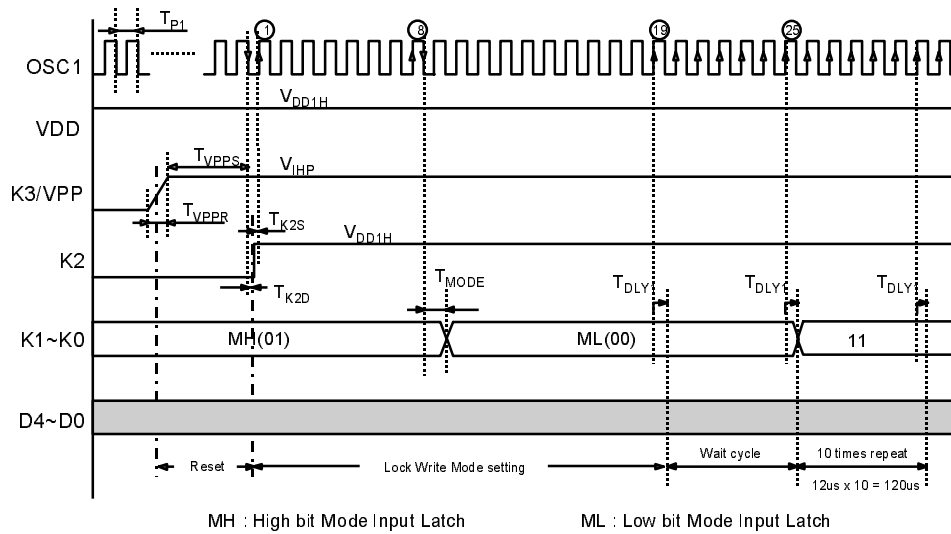

#. Note :

1. Internal system is reset at  $V_{PP} = 12.5V$  and  $K2 = \text{'Low'}$
2. The reset release ( $K2 = \text{'High'}$ ) must be set within  $OSC1 = \text{'Low'}$  state.  
(From this time,  $OSC1$  clock is counted.)
3. If not written during 10 times repeats (120us), repeat the 5 times until all is written.

4) Lock Bit Read Mode

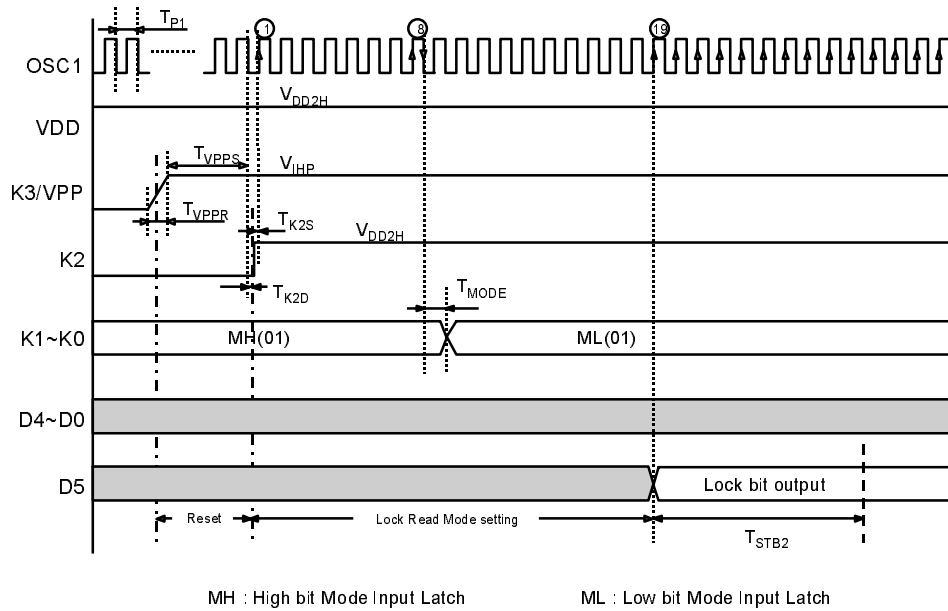

#. Note :

1. Internal system is reset at  $V_{PP} = 12.5V$  and  $K2 = \text{'Low'}$
2. The reset release ( $K2 = \text{'High'}$ ) must be set within  $OSC1 = \text{'Low'}$  state.  
(From this time,  $OSC1$  clock is counted.)
3. Lock data is outputted from D5 port.  
If you set Lock bit, the output data of D5 is always 'H'.

Program / Verify Timing Diagrams In MHz Version.

1) EPROM Write & Verify Mode (1Byte)

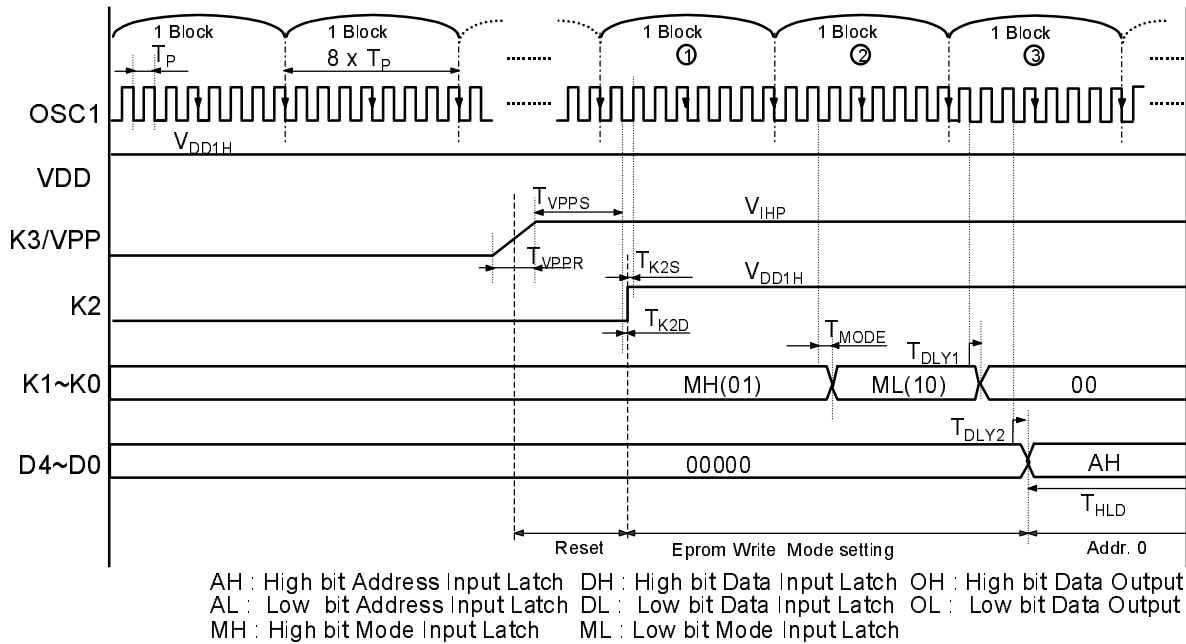

#. Note :

1. Internal system is reset at VPP = 12.5V and K2='Low'
2. OSC1 is made of a block of 8 x Tp clock.
3. From this time when the reset is released (K2='High'), OSC1 clock is counted by 1-bolck.
4. If not written during 10 times repeats (120us), repeat the 5 times until all is written.
5. For device verify. If you set Lock bit, output data is always `0F`h.

Continue to Next Page.

- Continue -

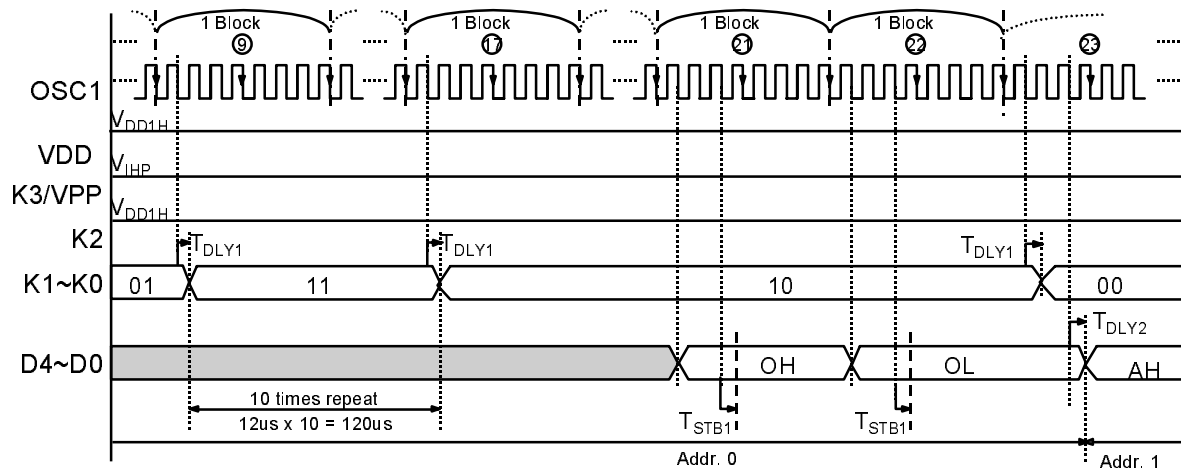
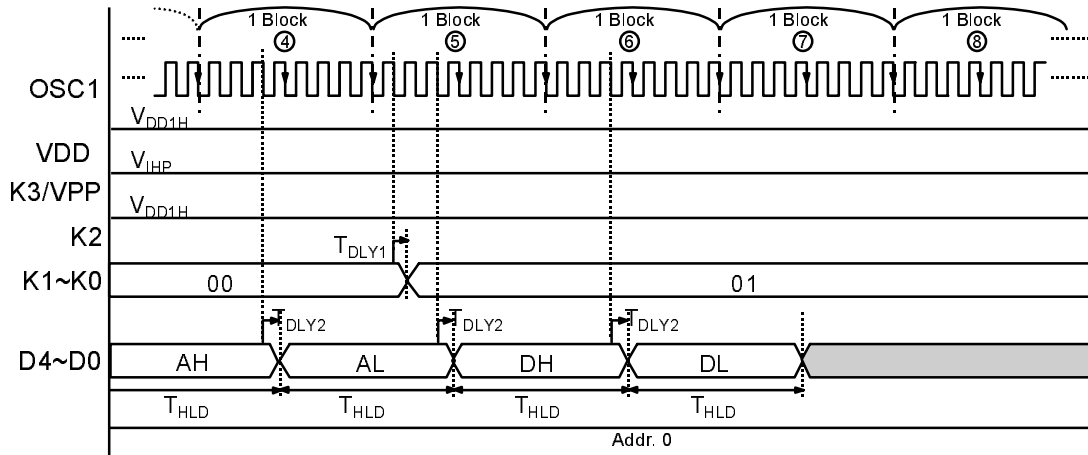

2) EPROM Read Mode

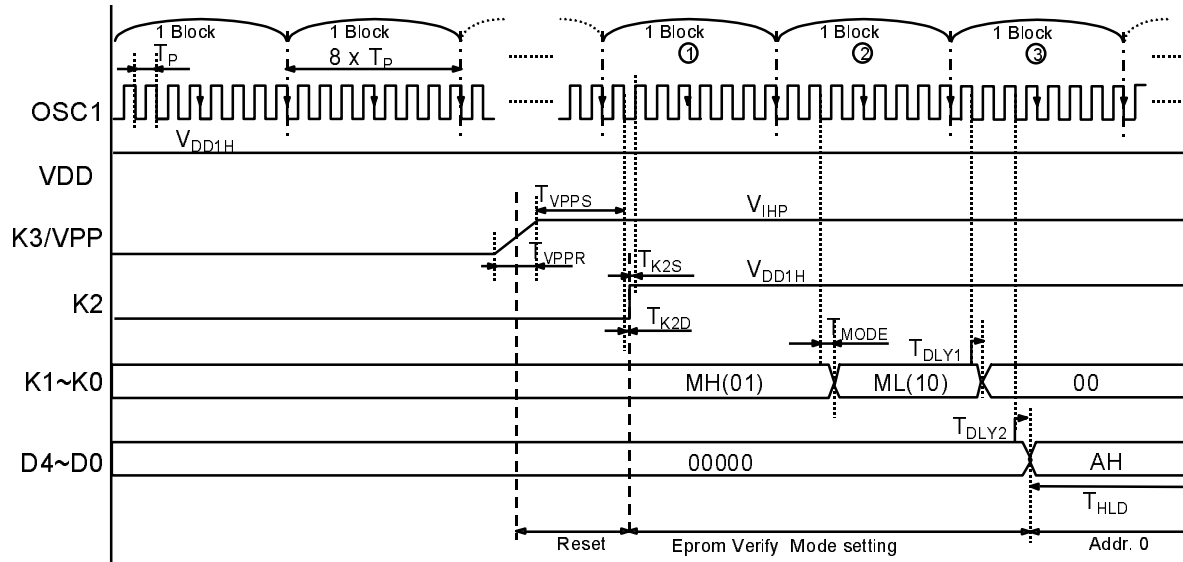

AH : High bit Address Input Latch	DH : High bit Data Input Latch	OH : High bit Data Output
AL : Low bit Address Input Latch	DL : Low bit Data Input Latch	OL : Low bit Data Output
MH : High bit Mode Input Latch	ML : Low bit Mode Input Latch	

#. Note :

1. Internal system is reset at VPP = 12.5V and K2='Low'
2. OSC1 is made of a block of 8 x Tp clock.
3. From this time when the reset is released (K2='High'), OSC1 clock is counted by 1-bolck.
4. For device verify. If you set Lock bit, output data is always `0F`h.

Continue to Next Page.



- Continue -

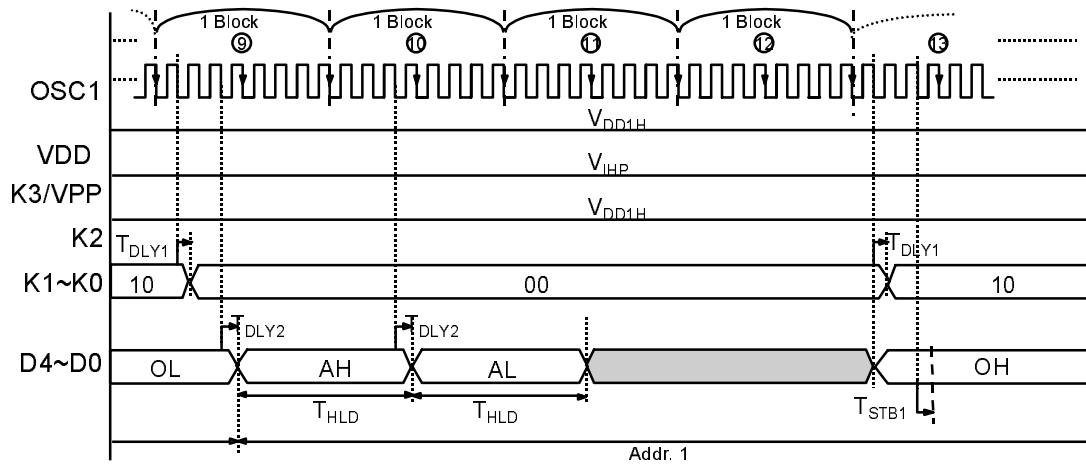
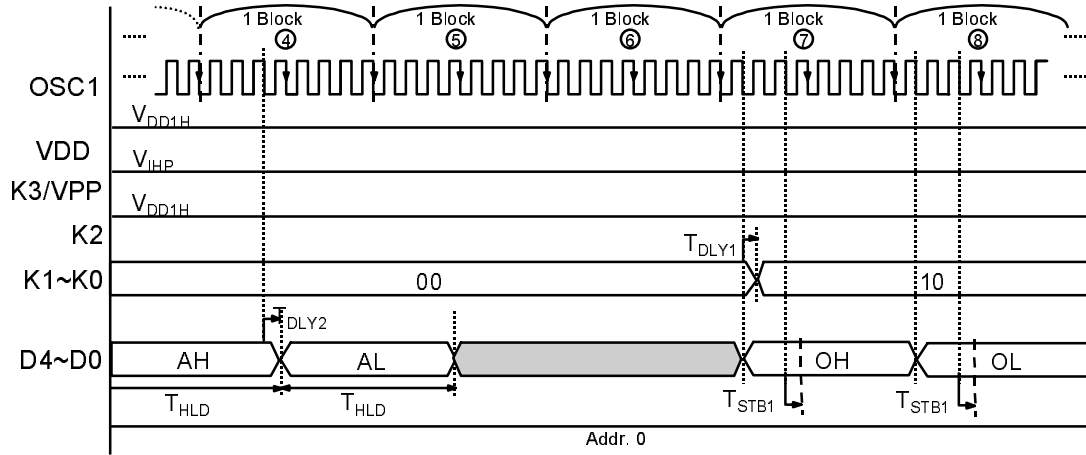

3) Lock Bit Write Mode

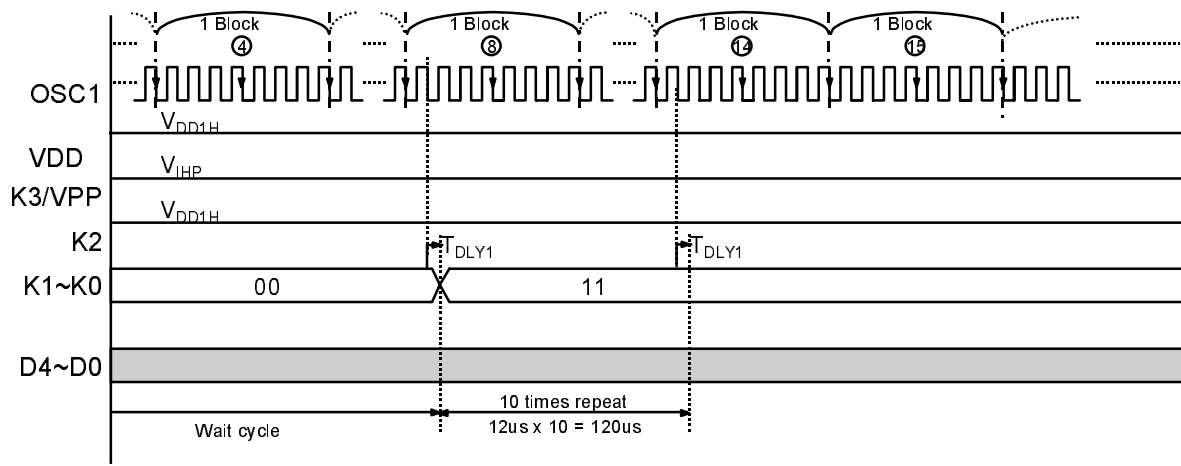
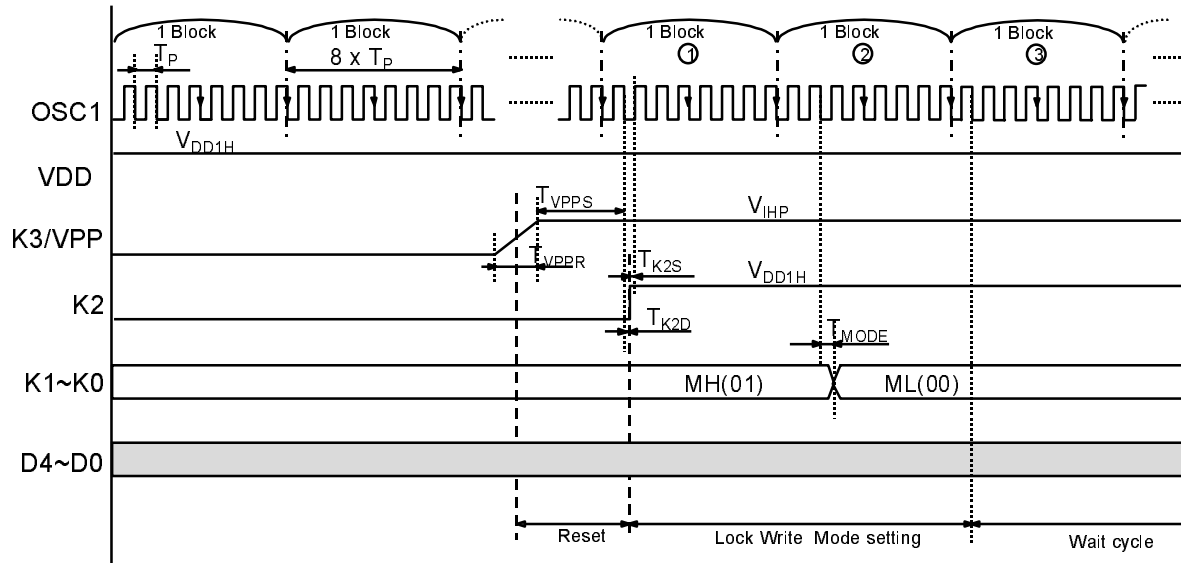

MH : High bit Mode Input Latch

ML : Low bit Mode Input Latch

#. Note :

1. Internal system is reset at  $V_{PP} = 12.5V$  and  $K2 = \text{'Low'}$
2. OSC1 is made of a block of  $8 \times T_p$  clock.
3. From this time when the reset is released ( $K2 = \text{'High'}$ ), OSC1 clock is counted by 1-block.
4. If not written during 10 times repeats(120us), repeat the 5 times until all is written.

4) Lock Bit Read Mode

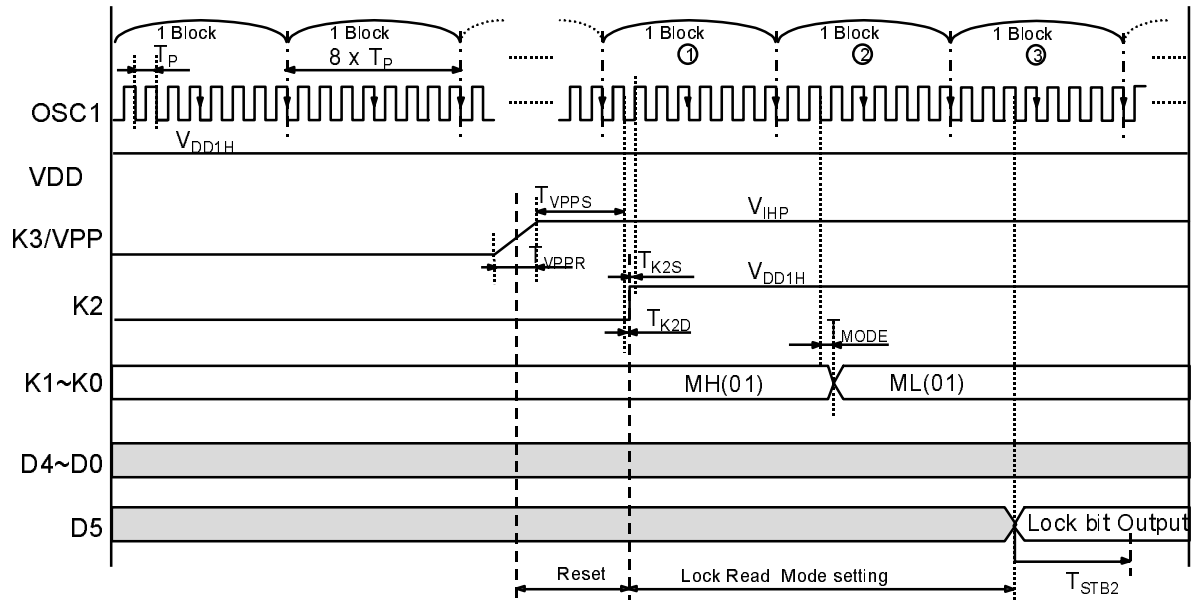

MH : High bit Mode Input Latch

ML : Low bit Mode Input Latch

#. Note :

1. Internal system is reset at  $V_{PP} = 12.5V$  and  $K2 = \text{'Low'}$
2. OSC1 is made of a block of  $8 \times T_P$  clock.
3. From this time when the reset is released ( $K2 = \text{'High'}$ ), OSC1 clock is counted by 1-block.
4. Lock data is outputted from D5 port.  
If you set Lock bit, the output data of D5 is always 'H'.

## Chapter 9. EPROM

### Caution when programming

Writing should be done at the defined voltage and timing. In case of EPROM mode, programming voltage is 12.5V. More than defined voltage can give device so great damage to destroy it. Before writing you had better ascertain the characteristics of socket and socket adapter of EPROM writer. It can happen to write error when you touch socket adapter or device. We recommend below flow to improve reliability after writing.

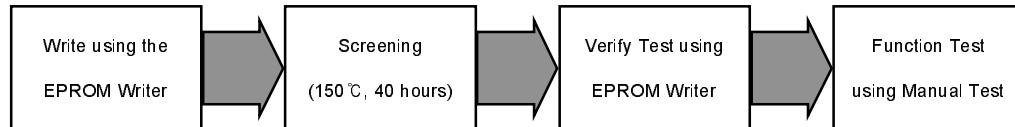

### ※ Timing Flowchart for Eprom Program / Verify.

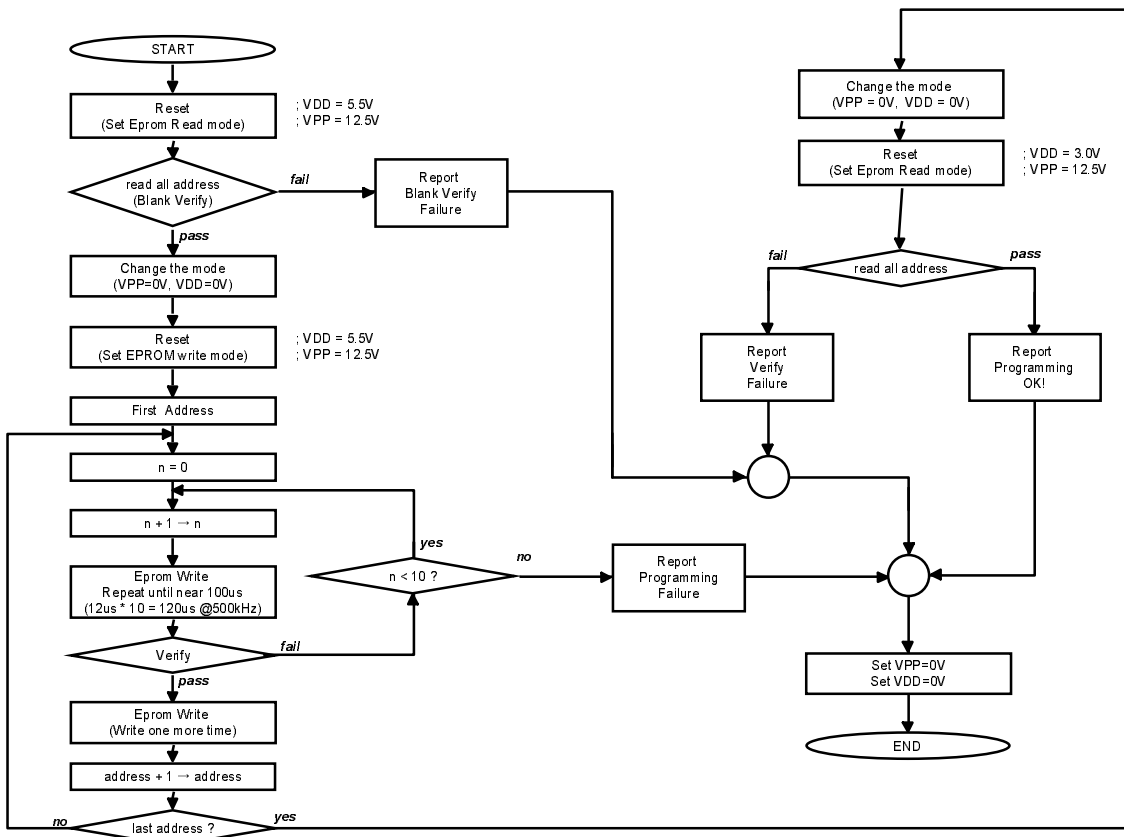

※ Timing Flowchart for Lock Bit Program / Verify.

