

GI1401 THRU GI1404

FAST EFFICIENT PLASTIC RECTIFIER

Reverse Voltage - 50 to 200 Volts Forward Current - 8.0 Amperes

TO-220AC

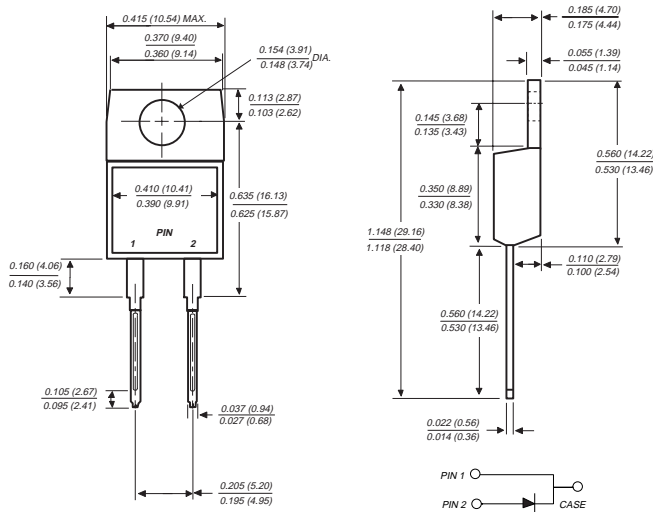

Dimensions in inches and (millimeters)

FEATURES

- ◆ Plastic package has Underwriters Laboratory Flammability Classification 94V-0
- ◆ Glass passivated chip junction
- ◆ Low power loss
- ◆ Low leakage current
- ◆ High surge capability
- ◆ Superfast recovery time for high efficiency
- ◆ High temperature soldering guaranteed: 250°C, 0.16" (4.06mm) from case for 10 seconds



MECHANICAL DATA

Case: JEDEC TO-220AC molded plastic body over passivated chip

Terminals: Lead solderable per MIL-STD-750, Method 2026

Polarity: As marked

Mounting Position: Any

Weight: 0.064 ounce, 1.81 grams

MAXIMUM RATINGS AND ELECTRICAL CHARACTERISTICS

Ratings at 25°C ambient temperature unless otherwise specified.

	SYMBOLS	GI1401	GI1402	GI1403	GI1404	UNITS
Maximum recurrent peak reverse voltage	V _{RRM}	50	100	150	200	Volts
Maximum RMS voltage	V _{RMS}	35	70	105	140	Volts
Maximum DC blocking voltage	V _{DC}	50	100	150	200	Volts
Maximum average forward rectified current at T _C =125°C	I _(AV)	8.0				Amps
Peak forward surge current 8.3ms single half sine-wave superimposed on rated load (JEDEC Method) at T _C =125°C	I _{FSM}	125.0				Amps
Maximum instantaneous forward voltage at: I _F =4A, T _J =100°C I _F =8A, T _J =100°C I _F =4A, T _J =25°C I _F =8A, T _J =25°C	V _F	0.800 0.895 0.900 0.975				Volts
Maximum DC reverse current at rated DC blocking voltage	I _R	5.0 150.0				μA
Maximum reverse recovery time (NOTE 1)	t _{rr}	35.0				ns
Typical junction capacitance (NOTE 2)	C _J	85.0				pF
Typical thermal resistance (NOTE 3) (NOTE 4)	R _{θJA} R _{θJC}	15.0 2.2				°C/W
Operating and storage temperature range	T _J , T _{STG}	-65 to +150				°C

NOTES:

- (1) Reverse recovery test conditions: I_F=0.5A, I_R=1.0A, I_{rr}=0.25A
- (2) Measured at 1.0 MHz and applied reverse voltage of 4.0 Volts
- (3) Thermal resistance from junction to ambient in free air, no heatsink
- (4) Thermal resistance from junction to case mounted on heatsink

RATINGS AND CHARACTERISTIC CURVES G11401 THRU G11404

FIG. 1 - FORWARD CURRENT DERATING CURVES

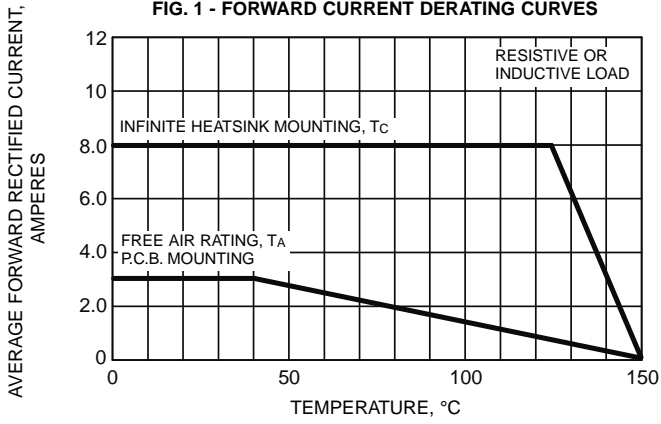

FIG. 2 - MAXIMUM NON-REPETITIVE PEAK FORWARD SURGE CURRENT

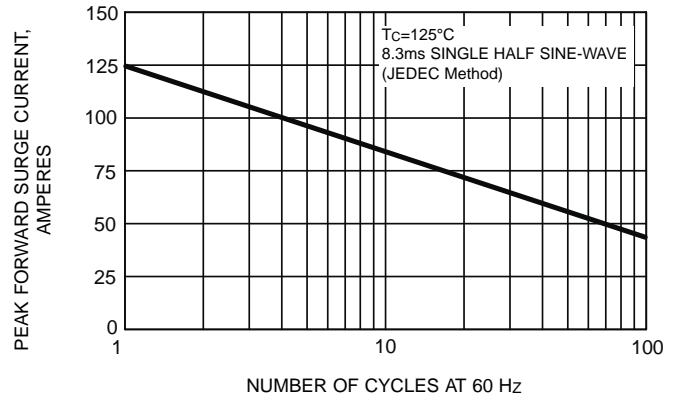

FIG. 3 - TYPICAL INSTANTANEOUS FORWARD CHARACTERISTICS

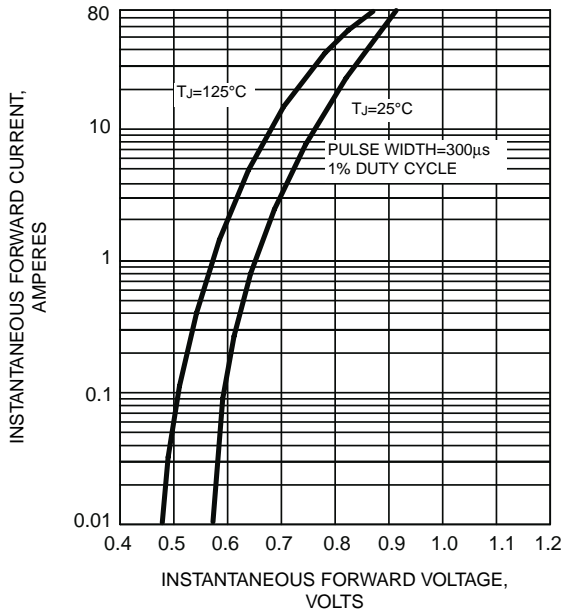

FIG. 4 - TYPICAL REVERSE LEAKAGE CHARACTERISTICS

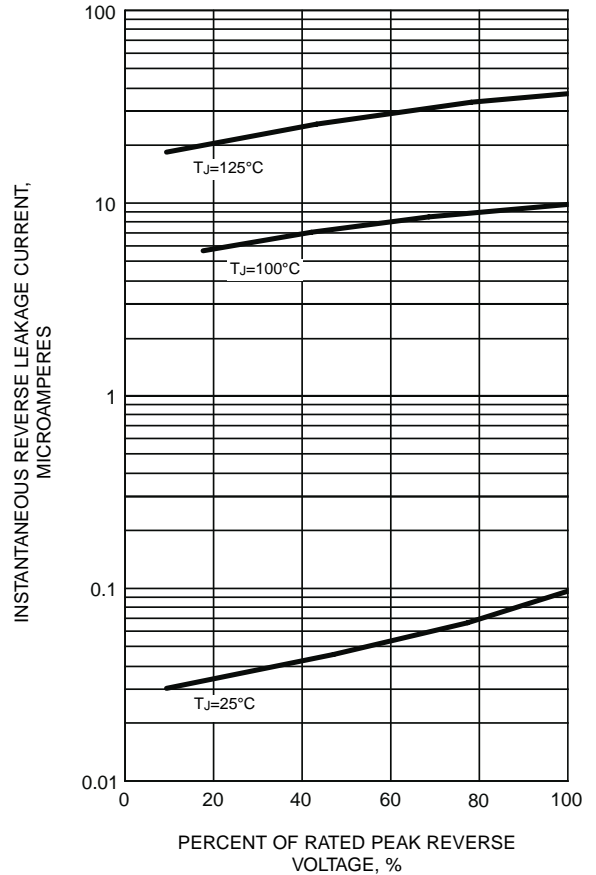

FIG. 5 - TYPICAL JUNCTION CAPACITANCE

