



Preliminary

GENERAL DESCRIPTION

EM73201 is an advanced single chip CMOS 4-bit micro-controller. It contains 2K-byte ROM, 52-nibble RAM, 4-bit ALU, 13-level subroutine nesting, 22-stage time base, one 12-bit timer/counter for the kernel function. EM73201 also contains 5 interrupt sources, 4 I/O ports (including 1 input port, 1 output port for LED driving, 2 bidirection I/O ports) built-in watch-dog-time counter and one high frequency clock output for modulating infrared signal.

Except low-power consumption and high speed, EM73201 also have a sleep and hold mode operation for the power saving function.

EM73201 is suitable for application in family appliance, consumer products and toy controller.

FEATURES

- Operation voltage : 2.4V to 6.0V (clock frequency: 32 KHz to 5 MHz)
- Clock source : Single clock system for RC , Crystal and external clock source, available by mask option.
- Instruction set : 109 powerful instructions.
- Instruction cycle time : Up to 2 μ s for 4.19MHz .
- ROM capacity : 2048 x 8 bits.
- RAM capacity : 52 x 4 bits.
- Input port : 1 port (P0).
- Output port : 1 port (P1).
- Bidirection I/O port : 2 ports (P7,P8).
- 12-bit timer/counter : One 12-bit timer/counter is programmable for timer, even counter and pulse width measurement mode.
- Built-in time base counter : 22 stages.
- Subroutine nesting : Up to 13 levels.
- Interrupt : External interrupt 2 input interrupt sources.
Internal interrupt 1 timer overflow interrupt,
1 time base interrupt.
- The built-in watch-dog-timer counter is available by mask option.
- Low voltage reset is available by mask option.
- High frequency clockout: Programmable high frequency clock output for modulating infrared signal.
- Power saving function : Sleep mode and Hold mode.
- Package type : EM73201H Chip form 22 pins.
EM73201AP DIP 18 pins.
EM73201BK SKINNY 22 pins.
EM73201CP DIP 16 pins.

APPLICATIONS

EM73201 is suitable for application in family appliance, consumer products and the toy controller.

Preliminary

PIN CONFIGURATIONS

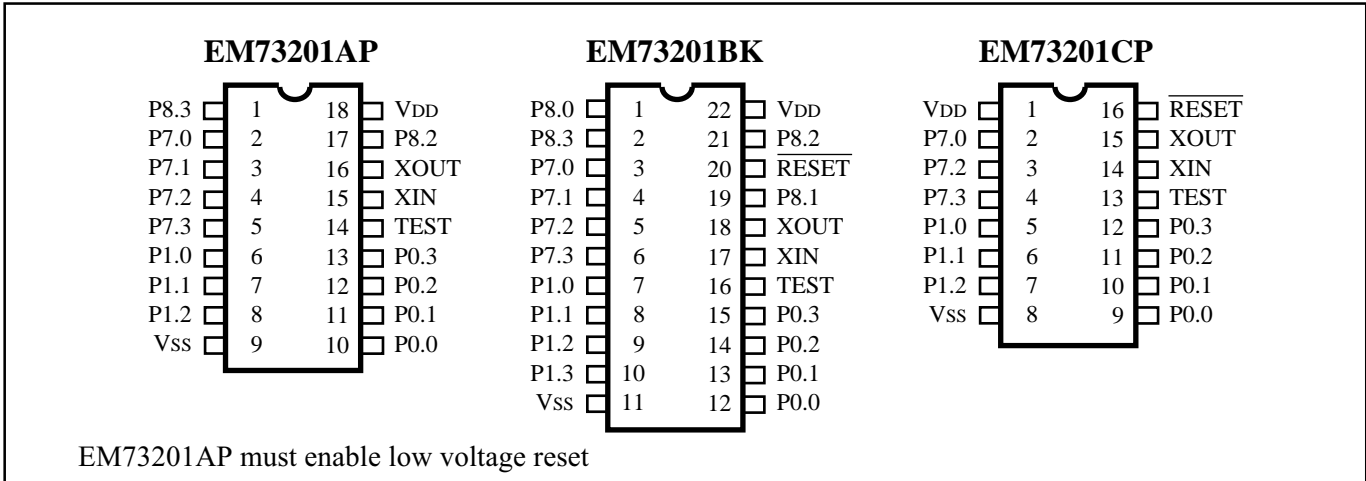

FUNCTIONAL BLOCK DIAGRAM

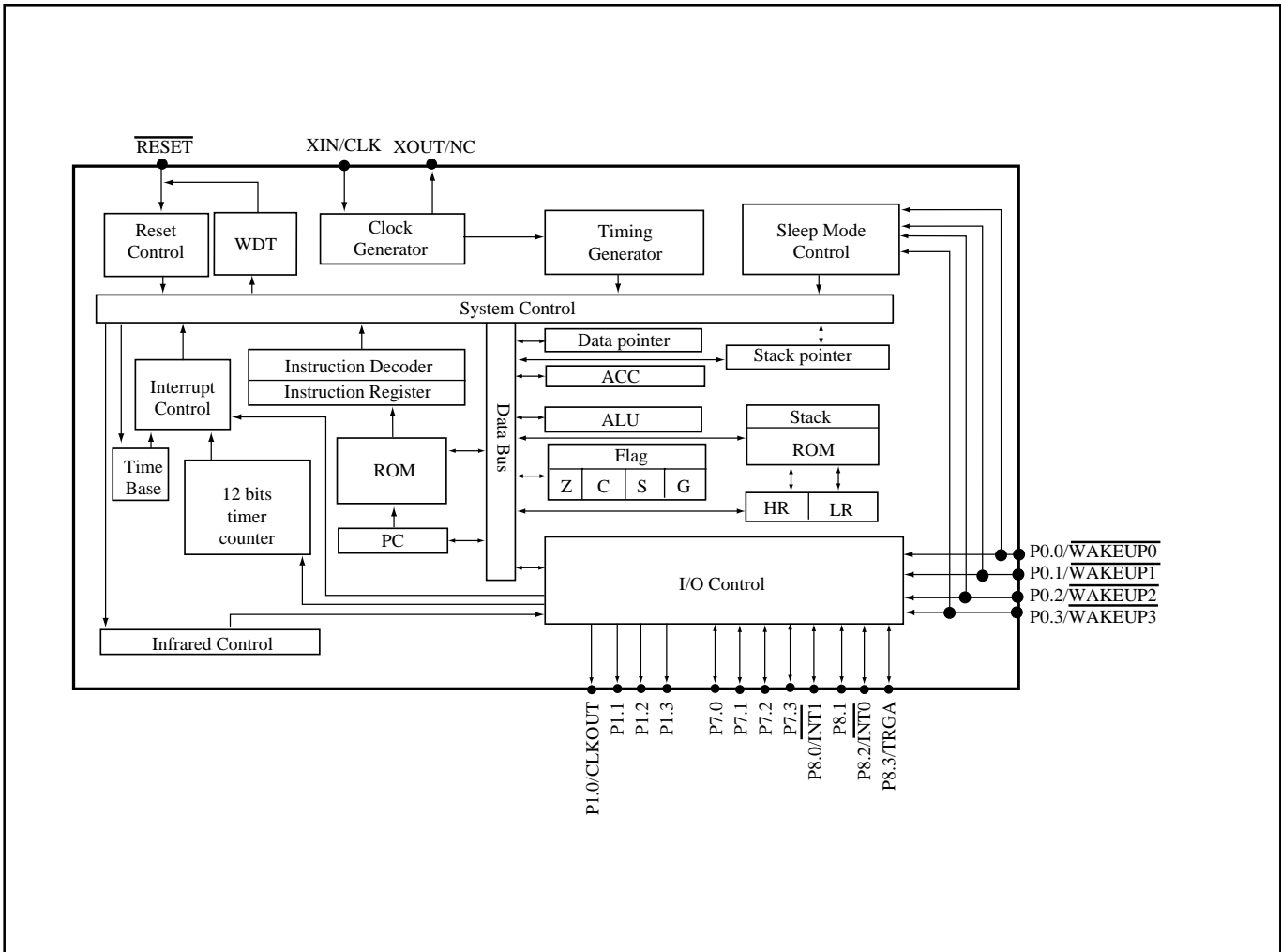

* This specification are subject to be changed without notice.

PIN DESCRIPTIONS

Preliminary

Symbol	Pin- Type	Function
V _{DD}		Power supply (+)
V _{SS}		Power supply (-)
RESET	RESET-A	System reset input signal, low active mask option: none pull-up
XIN/CLK	OSC-A/OSC-C	Crystal/RC or external clock source connecting pin
XOUT/NC	OSC-A	Crystal connecting pin or NC for RC osc. type
P(0..3)/WAKEUP0..3	INPUT-C	4-bit input port with Sleep/Hold releasing function mask option : none pull-up pull-down
P1.0/CLKOUT	OUTPUT-B	1-bit high current output pin for LED driving or clock output for infrared signal mask option : open-drain, normal sink open-drain, high sink normal source, normal sink normal source, high sink
P1(1..3)	OUTPUT-A	3-bit high current output pin for LED driving mask option : open-drain, normal sink open-drain, high sink normal source, normal sink normal source, high sink
P7(0..3)	I/O-U	4-bit bidirection I/O port mask option : open-drain, normal sink low source, normal sink normal source, normal sink normal source, high sink high source, high sink
P8.0/ $\overline{\text{INT1}}$, P8.2/ $\overline{\text{INT0}}$	I/O-W	2-bit bidirection I/O pins with external interrupt sources input mask option : open-drain, normal sink low source, normal sink normal source, normal sink normal source, high sink high source, high sink
P8.3/TRGA	I/O-V	1-bit bidirection I/O pin with timer/counter A external input mask option : open-drain, normal sink low source, normal sink normal source, normal sink normal source, high sink high source, high sink
P8.1	I/O-W	1-bit bidirection I/O pin mask option : open-drain, normal sink low source, normal sink normal source, normal sink normal source, high sink high source, high sink

Preliminary

FUNCTION DESCRIPTIONS

PROGRAM ROM (2K X 8 bits)

2 K x 8 bits program ROM contains user's program and some fixed data .

The basic structure of program ROM can be divided into 5 parts.

1. Address 000h: Reset start address.
2. Address 002h - 00Ch: 4 kinds of interrupt service routine entry addresses .
3. Address 00Eh-086h : SCALL subroutine entry address, only available at 00Eh,016h,01Eh,026h, 02Eh, 036h, 03Eh, 046h, 04Eh, 056h, 05Eh, 066h, 06Eh, 076h ,07Eh, 086h .
4. Address 000h - 7FFh : LCALL subroutine entry address
5. Address 7E0h - 7FFh : The data region for 5-to-8 bits data conversion table .
6. Address 000h - 7FFh : Except used as above function, the other region can be used as user's program region.

address	2048 x 8 bits
000h	Reset start address
002h	INT0; External interrupt service routine entry address
004h	-----
006h	TRGA, Timer/counterA interrupt service routine entry address
008h	-----
00Ah	TBI; Time base interrupt service routine entry address
00Ch	INT1; External interrupt service routine entry address
00Eh	-----
086h	SCALL, subroutine call entry address
⋮	⋮
⋮	⋮
⋮	⋮
7FFh	

User's program and fixed data are stored in the program ROM. User's program is according the PC value to send next executed instruction code. Fixed data can be read out by two ways.

(1) Table-look-up instruction:

Table-look-up instruction is depended on the Data Pointer (DP) to indicate to ROM address, then to get the ROM code data.

LDAX $Acc \leftarrow ROM[DP]_L$
LDAXI $Acc \leftarrow ROM[DP]_H, DP+1$

DP is a 12-bit data register which can store the program ROM address to be the pointer for the ROM code data. First, user load ROM address into DP by instruction "STADPL, STADPM, STADPH", then user can get the lower nibble of ROM code data by instruction "LDAX" and higher nibble by instruction "LDAXI".

PROGRAM EXAMPLE: Read out the ROM code of address 777h by table-look-up instruction.

```
LDIA #07h;
STADPL   ; [DP]L ← 07h
STADPM   ; [DP]M ← 07h
STADPH   ; [DP]H ← 07h, Load DP=777h
:
LDL #00h;
LDH #03h;
LDAX     ; ACC ← 6h
```

Preliminary

```

STAMI    ; RAM[30] ← 6h
LDAXI    ; ACC ← 5h
STAM     ; RAM[31] ← 5h
:
ORG 777h
DATA 56h;
:
    
```

DATA RAM (52-nibble)

There is total 52 - nibble data RAM from address 00 to 33h
Data RAM includes 3 parts: zero page region, stacks and data area.

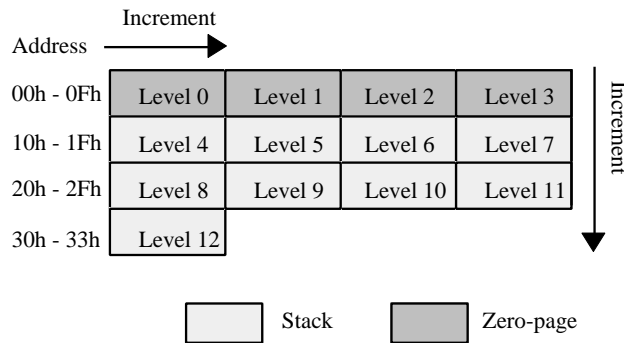

ZERO- PAGE:

From 00h to 0Fh is the location of zero-page. It is used as the pointer in zero-page addressing mode for the instruction of "STD #k,y; ADD #k,y; CLR y,b; CMP k,y".

PROGRAM EXAMPLE:

To write immediate data "07h" to address "03h" of RAM and to clear bit 2 of RAM.

```

STD #07h, 03h ; RAM[03] ← 07h
CLR 0Eh,2 ; RAM[0Eh]2 ← 0
    
```

STACK:

There are 13 - level (maximum) stack for user using for subroutine (including interrupt and CALL). User can assign any level be the starting stack by giving the level number to stack pointer (SP).
When user using any instruction of CALL or subroutine, before entry the subroutine, the previous PC address will be saved into stack until return from those subroutines, the PC value will be restored by the data saved in stack.

DATA AREA:

Except the special area used by user, the whole RAM can be used as data area for storing and loading general data.

ADDRESSING MODE

(1) Indirect addressing mode:

Indirect addressing mode indicates the RAM address by specified HL register.

```

For example: LDAM ; Acc ← RAM[HL]
              STAM ; RAM[HL] ← Acc
    
```

(2) Direct addressing mode:

Direct addressing mode indicates the RAM address by immediate data.

Preliminary

For example: LDA x ; Acc ← RAM[x]
 STA x ; RAM[x] ← Acc

(3) Zero-page addressing mode

For zero-page region, user can using direct addressing to write or do any arithmetic, comparison or bit manipulated operation directly.

For example: STD #k,y ; RAM[y] ← #k
 ADD #k,y ; RAM[y] ← RAM[y] + #k

PROGRAM COUNTER (2K ROM)

Program counter (PC) is composed by a 12-bit counter, which indicates the next executed address for the instruction of program ROM.

For a 2 K - byte size ROM, PC can indicate address form 000h - 7FFh, for BRANCH and CALL instructions, PC is changed by instruction indicating.

(1) Branch instruction:

SBR a

Object code: 00aa aaaa

Condition: SF=1; PC ← PC_{11-6.a} (branch condition satisfied)

PC

Hold original PC value+1	a	a	a	a	a	a
--------------------------	---	---	---	---	---	---

SF=0; PC ← PC + 1(branch condition not satisfied)

PC

Original PC value + 1

LBR a

Object code: 1100 aaaa aaaa aaaa

Condition: SF=1; PC ← a (branch condition satisfied)

PC

0	a	a	a	a	a	a	a	a	a	a	a
---	---	---	---	---	---	---	---	---	---	---	---

SF=0 ; PC ← PC + 2 (branch condition not satisfied)

PC

Original PC value + 2

(2) Subroutine instruction:

SCALL a

Object code: 1110 mnmn

Condition : PC ← a ; a=8n+6 ; n=1..15 ; a=86h, n=0

PC

0	0	0	0	a	a	a	a	a	a	a	a
---	---	---	---	---	---	---	---	---	---	---	---

LCALL a

Object code: 0100 0 aaa aaaa aaaa

Condition: PC ← a

Preliminary

PC

0	a	a	a	a	a	a	a	a	a	a	a
---	---	---	---	---	---	---	---	---	---	---	---

RET

Object code: 01 00 1 1 1 1

Condition: PC ← STACK[SP]; SP + 1

PC

The return address stored in stack											
------------------------------------	--	--	--	--	--	--	--	--	--	--	--

RTI

Object code: 0100 1101

Condition : FLAG. PC ← STACK[SP]; EI ← 1; SP + 1

PC

The return address stored in stack											
------------------------------------	--	--	--	--	--	--	--	--	--	--	--

(3) Interrupt acceptance operation:

When an interrupt is accepted, the original PC is pushed into stack and interrupt vector will be loaded into PC, The interrupt vectors are as following:

$\overline{INT0}$ (External interrupt from P8.2)

PC

0	0	0	0	0	0	0	0	0	0	1	0
---	---	---	---	---	---	---	---	---	---	---	---

TRGA (Timer A overflow interrupt)

PC

0	0	0	0	0	0	0	0	0	1	1	0
---	---	---	---	---	---	---	---	---	---	---	---

TBI (Time base interrupt)

PC

0	0	0	0	0	0	0	0	1	0	1	0
---	---	---	---	---	---	---	---	---	---	---	---

$\overline{INT1}$ (External interrupt from P8.0)

PC

0	0	0	0	0	0	0	0	1	1	0	0
---	---	---	---	---	---	---	---	---	---	---	---

(4) Reset operation:

PC

0	0	0	0	0	0	0	0	0	0	0	0
---	---	---	---	---	---	---	---	---	---	---	---

(5) Other operations:

For 1-byte instruction execution: PC + 1

For 2-byte instruction execution: PC + 2

ACCUMULATOR

Accumulator is a 4-bit data register for temporary data . For the arithmetic, logic and comparative operation .., ACC plays a role which holds the source data and result .

FLAGS

Preliminary

There are four kinds of flag, CF (Carry flag), ZF (Zero flag), SF (Status flag) and GF (General flag), these 4 1-bit flags are affected by the arithmetic, logic and comparative operation .
All flags will be put into stack when an interrupt subroutine is served, and the flags will be restored after RTI instruction executed .

(1) Carry Flag (CF)

The carry flag is affected by following operation:

- a. Addition : CF as a carry out indicator, when the addition operation has a carry-out, CF will be "1", in another word, if the operation has no carry-out, CF will be "0".
- b. Subtraction : CF as a borrow-in indicator, when the subtraction operation must has a borrow, in the CF will be "0", in another word, if no borrow-in, CF will be "1".
- c. Comparision: CF is as a borrow-in indicator for Comparision operation as the same as subtraction operation.
- d. Rotation: CF shifts into the empty bit of accumulator for the rotation and holds the shift out data after rotation.
- e. CF test instruction : For TFCFC instruction, the content of CF sends into SF then clear itself "0".
For TTSFC instruction, the content of CF sends into SF then set itself "1".

(2) Zero Flag (ZF)

ZF is affected by the result of ALU, if the ALU operation generate a "0" result, the ZF will be "1", otherwise, the ZF will be "0".

(3) Status Flag (SF)

The SF is affected by instruction operation and system status .

- a. SF is initiated to "1" for reset condition .
- b. Branch instruction is decided by SF, when SF=1, branch condition will be satisfied, otherwise, branch condition will not be satisfied by SF = 0 .

(4) General Flag (GF)

GF is a one bit general purpose register which can be set, clear, test by instruction SGF, CGF and TGS.

PROGRAM EXAMPLE:

Check following arithmetic operation for CF, ZF, SF

	CF	ZF	SF
LDIA #00h;	-	1	1
LDIA #03h;	-	0	1
ADDA #05h;	-	0	1
ADDA #0Dh;	-	0	0
ADDA #0Eh;	-	0	0

Preliminary

ALU

The arithmetic operation of 4 - bit data is performed in ALU unit . There are 2 flags can be affected by the result of ALU operation, ZF and SF . The operation of ALU can be affected by GF only .

ALU STRUCTURE

ALU supported user arithmetic operation function, including : addition, subtraction and rotaion.

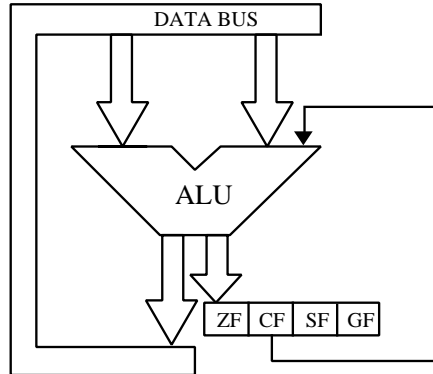

ALU FUNCTION

(1) Addition:

For instruction ADDAM, ADCAM, ADDM #k, ADD #k,y ALU supports addition function. The addition operation can affect CF and ZF. For addition operation, if the result is "0", ZF will be "1", otherwise, not equal "0", ZF will be "0", When the addition operation has a carry-out. CF will be "1", otherwise, CF will be "0".

EXAMPLE:

Operation	Carry	Zero
3+4=7	0	0
7+F=6	1	0
0+0=0	0	1
8+8=0	1	1

(2) Subtraction:

For instruction SUBM #k, SUBA #k, SBCAM, DECM... ALU supports user subtraction function . The subtraction operation can affect CF and ZF, For subtraction operation, if the result is negative, CF will be "0", it means a borrow out, otherwise, if the result is positive, CF will be "1". For ZF, if the result of subtraction operation is "0", the ZF will be "1", otherwise, ZF will be "0".

EXAMPLE:

Operation	Carry	Zero
8-4=4	1	0
7-F= -8(1000)	0	0
9-9=0	1	1

Preliminary

(3) Rotation:

There are two kinds of rotation operation, one is rotation left, the other is rotation right.
RLCA instruction rotates Acc value to left, shift the CF value into the LSB bit of Acc and the shift out data will be hold in CF.

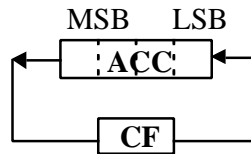

RRCA instruction operation rotates Acc value to right, shift the CF value into the MSB bit of Acc and the shift out data will be hold in CF.

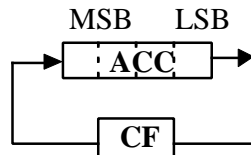

PROGRAM EXAMPLE: To rotate Acc right and shift a "1" into the MSB bit of Acc .

TTCFS; CF ← 1

RRCA; rotate Acc right and shift CF=1 into MSB.

HL REGISTER

HL register are two 4-bit registers, they are used as a pair of pointer for the address of RAM memory and also 2 independent temporary 4-bit data registers. For some instruction, L register can be a pointer to indicate the pin number (Port7) .

HL REGISTER STRUCTURE

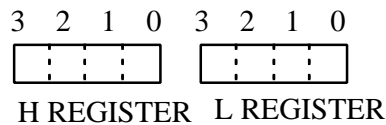

HL REGISTER FUNCTION

(1) For instruction : LDL #k, LDH #k, THA, THL, INCL, DECL, EXAL, EXAH, HL register used as a temporary register .

PROGRAM EXAMPLE: Load immediate data "5h" into L register, "Dh" into H register.

LDL #05h;

LDH #0Dh;

(2) For instruction LDAM, STAM, STAMI ..., HL register used as a pointer for the address of RAM memory.

PROGRAM EXAMPLE: Store immediate data #Ah into RAM of address 35h.

Preliminary

```
LDL #5h;
LDH #3h;
STDMI #0Ah; RAM[35] ← Ah
```

(3) For instruction : SELP, CLPL, TFPL, L register be a pointer to indicate the bit of I/O port.

When LR = C - F, indicate P7.0 - P7.3

PROGRAM EXAMPLE: To set bit 2 of Port7 to "1"

```
LDL #0Eh;
SEPL ; P7.2 ← 1
```

STACK POINTER (SP)

Stack pointer is a 4-bit register which stores the present stack level number. Before using stack, user must set the SP value first, CPU will not initiate the SP value after reset condition . When a new subroutine is accepted, the SP will be decreased one automatically, in another word, if returning from a subroutine, the SP will be increased one . The data transfer between ACC and SP is by instruction of "LDASP" and "STASP".

DATA POINTER (DP)

Data pointer is a 12-bit register which stores the address of ROM can indicate the ROM code data specified by user (refer to data ROM).

CLOCK AND TIMING GENERATOR

The clock generator is supported by a single clock system, the clock source comes from crystal (resonator or RC oscillation is decided by mask option . the working frequency range is 32 K Hz to 5 MHz depending on the working voltage.

CLOCK AND TIMING GENERATOR STRUCTURE

The clock generator connects outside components (crystal or resonator by XIN and XOUT pin for crystal osc type, Resistor and capacitor by CLK pin for RC osc type, these two type is decided by mask option). the clock generator generates a basic system clock "fc". When CPU sleeping, the clock generator will be stoped until the sleep condition released. The system clock control generates 4 basic phase signals (S1, S2, S3, S4) and system clock .

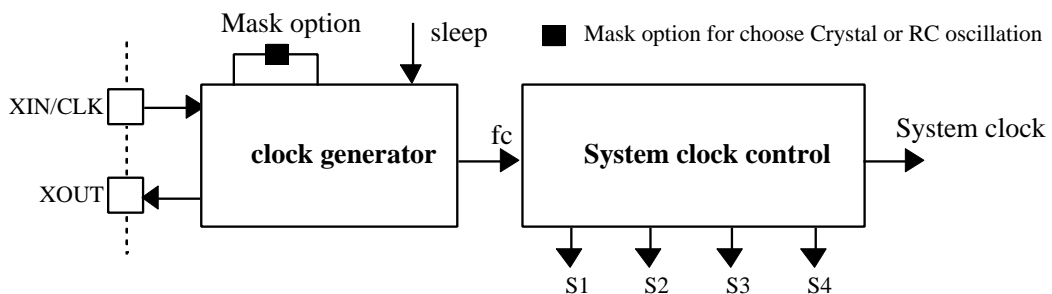

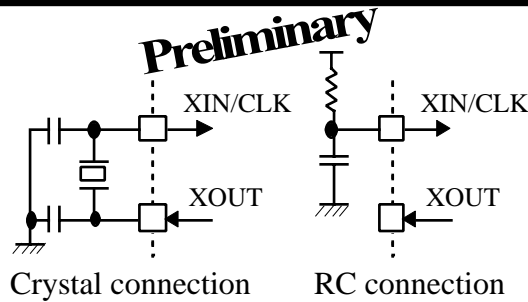

CLOCK AND TIMING GENERATOR FUNCTION

The frequency of f_c is the oscillation frequency for XIN, XOUT by crystal (resonator) or for CLK by RC osc.

When CPU sleeps, the XOUT pin will be in "high" state .

When user chooses RC osc, XOUT pin is no used .

The instruction cycle equal 8 basic clock f_c .

$$1 \text{ instruction cycle} = 8 / f_c$$

TIMING GENERATOR AND TIME BASE

The timing generator produces the system clock from basic clock pulse which can be normal mode or slow mode clock.

$$1 \text{ instruction cycle} = 8 \text{ basic clock pulses}$$

There are 22 stages time base .

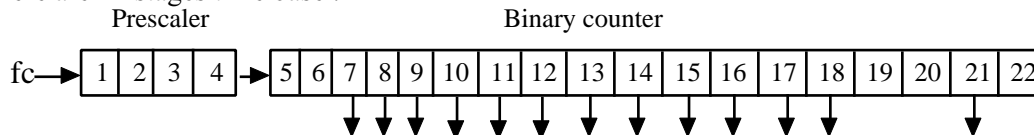

When working in the single clock mode, the timebase clock source is come from f_c that is RC oscillation.

Time base provides basic frequency for following function:

1. TBI (time base interrupt) .
2. Timer/counter, internal clock source.
3. Warm-up time for sleep - mode releasing.

TIME BASE INTERRUPT (TBI)

The time base can be used to generate a fixed frequency interrupt . There are 8 kinds of frequencies can be selected by setting "25"

Single clock mode

P25 3 2 1 0

(initial value 0000)

0 0 x x: Interrupt disable

0 1 0 0: Interrupt frequency $XIN / 2^{10}$ Hz

0 1 0 1: Interrupt frequency $XIN / 2^{11}$ Hz

0 1 1 0: Interrupt frequency $XIN / 2^{12}$ Hz

0 1 1 1: Interrupt frequency $XIN / 2^{13}$ Hz

1 1 0 0: Interrupt frequency $XIN / 2^9$ Hz

1 1 0 1: Interrupt frequency $XIN / 2^8$ Hz

1 1 1 0: Interrupt frequency $XIN / 2^{15}$ Hz

1 1 1 1: Interrupt frequency $XIN / 2^{17}$ Hz

1 0 x x: Reserved

Preliminary

TIMER / COUNTER (TIMERA)

Timer/counters can support user three special functions:

1. Even counter
2. Timer.
3. Pulse-width measurement.

These three functions can be executed by timer/counter.

For timerA, the counter data is saved in timer register TAH, TAM, TAL, which user can set counter initial value and read the counter value by W/B instruction "LDATAH (B,L), STATAH (B,L)".

The counter can be set initial value and send counter value to timer register. P28 is the command port for timerA , user can choose different operation mode and different internal clock rate by setting the port. When timer/counter overflow, it will generate a TRGA interrupt request to interrupt control unit.

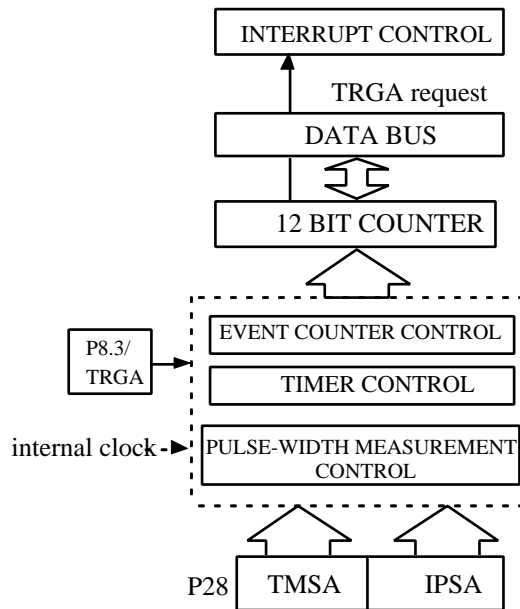

TIMER/COUNTER CONTROL

P8.3/TRGA is the external timer inputs for timerA, it used in event counter and pulse-width measurement mode.

Timer/counter command port: P28 is the command port for timer/counterA.

Port 28		TMSA		IPSA		TIMER/COUNTER MODE SELECTION	
3	2	1	0	TMSA	IPSA	TMSA	Function description
Initial state: 0000							
				0	0	0 0	Stop
				0	1	0 1	Event counter mode
				1	0	1 0	Timer mode
				1	1	1 1	Pulse width measurement mode

Preliminary

INTERNAL PULSE-RATE SELECTION	
IPSA	Function description
0 0	$XIN/2^0$ Hz
0 1	$XIN/2^{14}$ Hz
1 0	$XIN/2^{18}$ Hz
1 1	$XIN/2^{22}$ Hz

TIMER/COUNTER FUNCTION

EVENT COUNTER MODE

For event counter mode, timer/counter increases one at any rising edge of P8.3/TRGA for timerA. When timerA counts overflow, it will give interrupt control an interrupt request TOFIA.

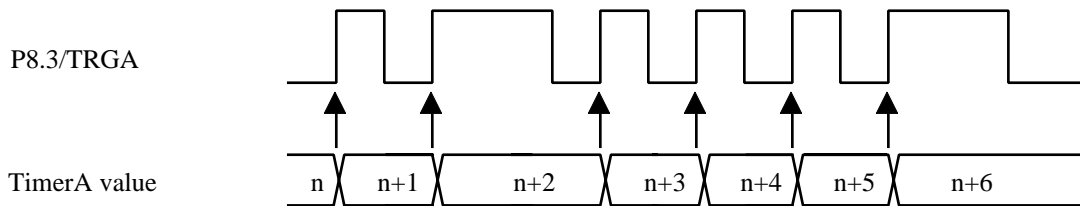

PROGRAM EXAMPLE: Enable timerA with P28.

LDIA #0100B;

OUTA P28; Enable timerA with event counter mode

TIMER MODE

For timer mode ,timer/counter increase one at any rising edge of internal pulse . User can choose 4 kinds of internal pulse rate by setting IPSA for timerA.

When timer/counter counts overflow, TRGA will be generated to interrupt control unit.

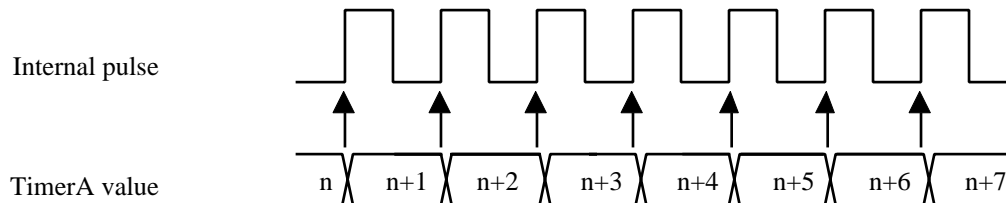

PROGRAM EXAMPLE: To generate TRGA interrupt request after 60 ms with system clock XIN=4MHz

LDIA #0100B;

EXAE; enable mask 2

EICIL 110111B; interrupt latch ←0, enable EI

LDIA #06H;

STATAL;

Preliminary

```
LDIA #01H;
STATAM;
LDIA #0FH;
STATAH;
LDIA #1000B;
OUTA P28; enable timerA with internal pulse rate: XIN/210 Hz
```

NOTE: The preset value of timer/counter register is calculated as following procedure.
 Internal pulse rate: $XIN/2^{10}$; $XIN = 4MHz$
 The time of timer counter count one = $2^{10} / XIN = 1024/4000=0.256ms$
 The number of internal pulse to get timer overflow = $60 ms/ 0.256ms = 234.375 = 0EAH$
 The preset value of timer/counter register = $1000H - 0EAH = 0F16H$

PULSE WIDTH MEASUREMENT MODE

For the pulse width measurement mode, the counter only increased by the rising edge of internal pulse rate as external timer/counter input (P8.3/TRGA), interrupt request will be generated as soon as timer/counter overflow.

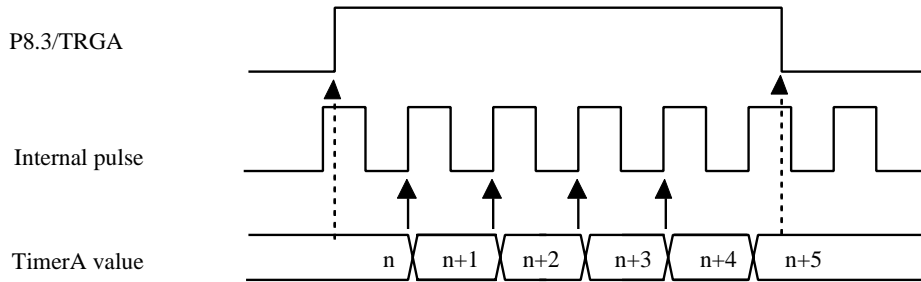

PROGRAM EXAMPLE: Enable timerA by pulse width measurement mode .

```
LDIA #1100B;
OUTA P28; Enable timerA with pulse width measurement mode.
```

INTERRUPT FUNCTION

There are 4 interrupt sources, 2 external interrupt sources, 2 internal interrupt sources . Multiple interrupts are admitted according the priority .

Type	Interrupt source	Priority	Interrupt Latch	Interrupt Enable condition	Program ROM entry address
External	External interrupt($\overline{INT0}$)	1	IL5	EI=1	002h
Internal	Reserved	2	IL4	EI=1, MASK3=1	004h
Internal	TimerA overflow interrupt (TRGA)	3	IL3	EI=1, MASK2=1	006h
Internal	Reserved	4	IL2	EI=1, MASK1=1	008h
Internal	Time base interrupt(TBI)	5	IL1		00Ah
External	External interrupt(INT1)	6	IL0	EI=1,MASK0=1	00Ch

Preliminary

INTERRUPT STRUCTURE

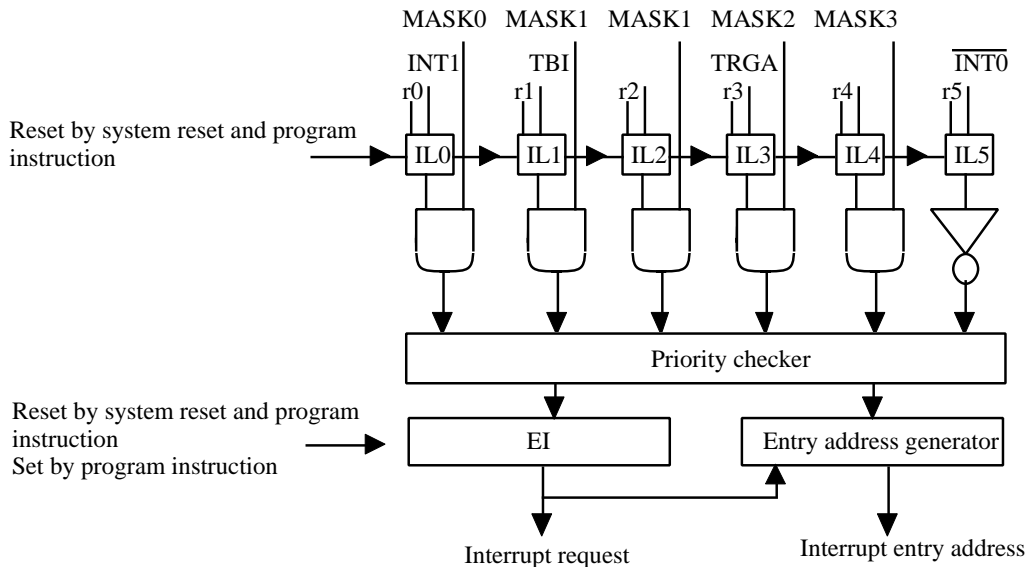

Interrupt controller:

- IL0-IL5 : Interrupt latch . Hold all interrupt requests from all interrupt sources. ILr can not be set by program, but can be reset by program or system reset, so IL only can decide which interrupt source can be accepted.
- MASK0-MASK3 : Except $\overline{\text{INT0}}$,MASK register can permit or inhibit all interrupt sources.
- EI : Enable interrupt Flip-Flop can permit or inhibit all interrupt sources, when interrupt happened, EI is cleared to "0" automatically, after RTI instruction happened, EI will be set to "1" again .

Priority checker: Check interrupt priority when multiple interrupts happened.

INTERRUPT FUNCTION

The procedure of interrupt operation:

1. Push PC and all flags to stack.
2. Set interrupt entry address into PC.
3. Set SF= 1.
4. Clear EI to inhibit other interrupts happened.
5. Clear the IL for which interrupt source has already be accepted.
6. To excute interrupt subroutine from the interrupt entry address.
7. CPU accept RTI, restore PC and flags from stack . Set EI to accept other interrupt requests.

PROGRAM EXAMPLE: To enable interrupt of " $\overline{\text{INT0}}$, TRGA"

```
LDIA #1100B;
EXAE; set mask register "1100B"
EICIL 111111B ; enable interrupt F.F.
```

POWER SAVING FUNCTION (Sleep / Hold function)

Preliminary

During sleep and hold condition, CPU holds the system's internal status with a low power consumption, for the sleep mode, the system clock will be stoped in the sleep condition and system need a warm up time for the stability of system clock running after wakeup . In the other way, for the hold mode, the system clock does not stop at all and it does not need a warm-up time any way.

The sleep and hold mode is controlled by Port 16 and released by P0(0..3)/WAKEUP0-3.

P16 3 2 1 0

WM	SE	SWWT	initial value :0000
----	----	------	---------------------

WM	Set wake-up release mode
0	Wake-up in edge release mode
1	Reserved

SWWT	Set wake-up warm-up time
0 0	2^{18} /XIN
0 1	2^{14} /XIN
1 0	2^{16} /XIN
1 1	Hold mode

SE	Enable sleep/hold
0	Reserved
1	Enable sleep / hold mode

Sleep and hold condition:

1. Osc stop (sleep only) and CPU internal status held .
2. Internal time base clear to"0"
3. CPU internal memory ,flags, register, I/O held original states.
4. Program counter hold the executed address after sleep release.

Release condition:

1. Osc start to oscillating.(sleep only)
2. Warm-up time passing (sleep only).
3. According PC to execute the following program.

There is one kind of sleep/hold release mode .

1.Edge release mode:

Release sleep/hold condition by the falling edge of any one of P0(0..3)/WAKEUP0-3.

Note : There is only one mask option for wakeup function in EM73201. So,the wakeup function of P0(0..3)/WAKEUP0..3 are enabled or disabled together.

INFRARED SIGNAL

The infrared signal generator supports user different frequencies and duties clock signal by P1.0/CLKOUT pin.

The basic structure of infrared signal generator is composed by a frequency divider and a duty controller, these two parts generate differen frequencies and dutyies according to the command port, Port4 and Port5, assigned . When the CPU is reseted, the CPU is reseted, the P1.0/CLKOUT pin will keep high.

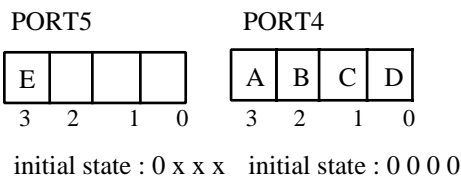

Preliminary

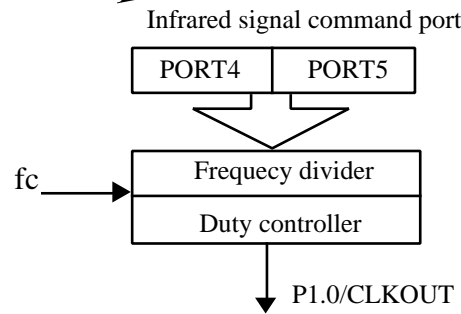

E	A	B	C	D	CLK OUT
X	0	X	X	X	HIGH
1	1	X	X	X	$fc/12$
0	1	0	0	0	$fc/8$
0	1	0	0	1	$fc/16$
0	1	0	1	0	$fc/32$
0	1	0	1	1	$fc/64$
0	1	1	0	0	LOW
0	1	1	0	1	$fc/16$; 1/4 duty
0	1	1	1	0	$fc/16$; 1/2 duty
0	1	1	1	1	$fc/16$; 3/4 duty

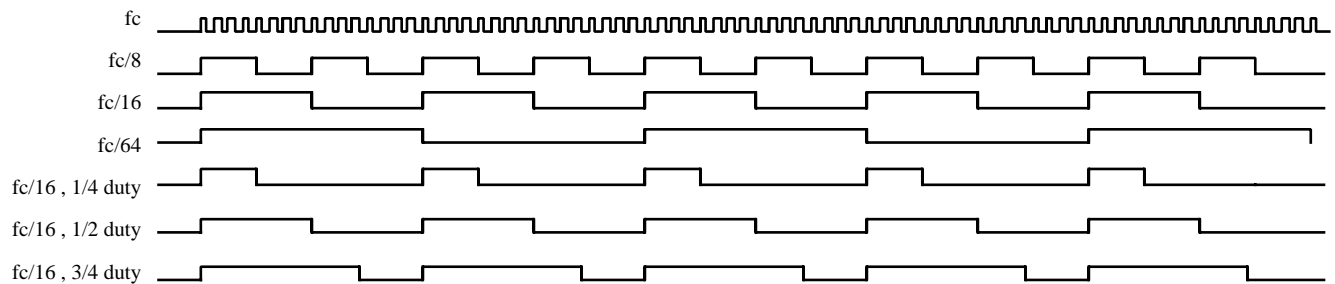

Program example:

```
To disable CLKOUT before sleep.
LDIA #0000B;
OUTA P5;
OUTA P4; set clkout pin in high state
LDIA #0100B;
OUTA P16; Sleep
:
```

```
To enable a CLKOUT signal with frequency
fc/16, 3/4 duty .
LDIA #0000B;
OUTA P5;
LDIA #1111B;
OUTA P4;
:
```

WATCH-DOG-TIMER

Watch-dog-timer (WDT) can help user to detect the malfunction (runaway) of CPU and give system a time up signal every certain time. User can use the time up signal to give system a reset signal when system is fail. The watch-dog-timer is enabled or disabled by mask option. If the mask option of WDT is enabled and the CPU is reseted or waked up, the WDT will be cleared and counting. When the CPU is sleeping, the WDT will be disabled.

The basic structure of watch-dog-timer control is composed by a 4-stage binary counter and a control unit. The WDT counter counts for a certain time to check the CPU status, if there is no malfunction happened, the counter will be cleared and counting. Otherwise, if there is a malfunction happened, the WDT control will send a signal (low active) to reset CPU. The WDT checking period is assign by P21 (WDT command port).

Preliminary

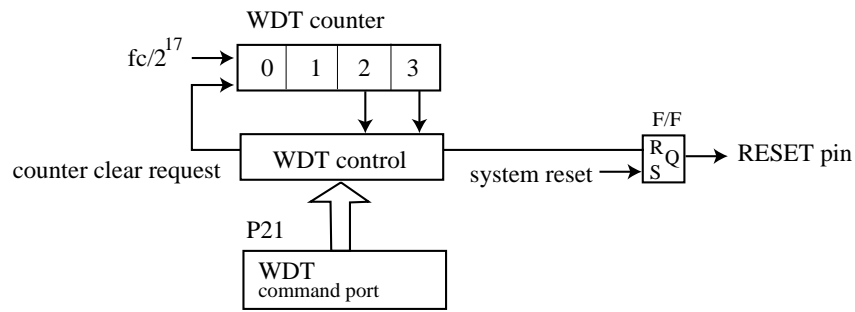

P21 is the control port of watch-dog-timer, and the WDT time up signal is connected to reset pin, user can use this time up signal (active low) to reset CPU and initialize system.

P21 3 2 1 0 initial value :0000

CWC	*	*	WDT
-----	---	---	-----

CWC	Clear watch-dog-timer counter
0	Clear counter then return to 1
1	Nothing

WDT	Set watch-dog-timer detect time	System clock frequency	
		4MHz	32KHz
0	$3 \times 2^{17} / fc$	98ms	12sec
1	$7 \times 2^{17} / fc$	229ms	28sec

Program example:

```
To clear WDT with  $7 \times 2^{17}/fc$  detection time.
LDIA #0001B;
OUTA P21      ; set WDT detection time and clear WDT counter
:
```

RESETTING FUNCTION

When CPU in normal working condition and $\overline{\text{RESET}}$ pin holds in low level for three instruction cycles at least, then CPU begins to initialize the whole internal states, and when $\overline{\text{RESET}}$ pin changes to high level, CPU begins to work in normal condition.

The CPU internal state during reset condition is as following table :

Hardware condition in RESET state	Initial value
Program counter	000h
Status flag	01h
Interrupt enable flip-flop (EI)	00h
MASK0 ,1, 2, 3	00h
Interrupt latch(IL)	00h
P4, P5, P16, P25, P28	00h
P1, P7, P8	0Fh
XIN	Start oscillation

Preliminary

The RESET pin is a hysteresis input pin and has a pull-up resistor available by mask option. The simplest RESET circuit is connect RESET pin with a capacitor to V_{SS} and a diode to V_{DD} .

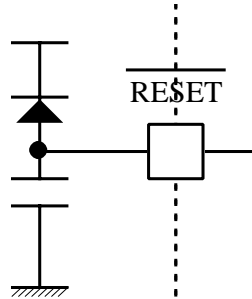

EM73201 I/O PORT DESCRIPTION :

Port	Input function		Output function		Note
0	E	Input port , wakeup function			
1		--	E	with LED driving, P1.0 is shared with CLKOUT	
2		--		--	
3		--		--	
4		--	I	Infrared signal control register	
5		--	I	Infrared signal control register	
6		--		--	
7	E	Input port	E	Output port	
8	E	Input port, external interrupt input	E	Output port	
9		--		--	
10		--		--	
11		--		--	
12		--		--	
13		--		--	
14		--		--	
15		--		--	
16			I	Sleep/Hold mode control register	
17				--	
18				--	
19				--	
20				--	
21			I	WDT control register	
22				--	
23				--	
24				--	
25			I	Timebase control register	
26				--	
27				--	
28			I	Timer/counter A control register	
29				--	
30				--	
31				--	



Preliminary

ABSOLUTE MAXIMUM RATINGS

Items	Sym.	Ratings	Conditions
Supply Voltage	V_{DD}	-0.5V to 6V	
Input Voltage	V_{IN}	-0.5V to $V_{DD}+0.5V$	
Output Voltage	V_O	-0.5V to $V_{DD}+0.5V$	
Power Dissipation	P_D	300mW	$T_{OPR}=50^{\circ}C$
Operating Temperature	T_{OPR}	0°C to 50°C	
Storage Temperature	T_{STG}	-55°C to 125°C	

RECOMMENDED OPERATING CONDITIONS

Items	Sym.	Ratings	Condition
Supply Voltage	V_{DD}	2.4V to 6.0V	
Input Voltage	V_{IH}	$0.90 \times V_{DD}$ to V_{DD}	
	V_{IL}	0V to $0.10 \times V_{DD}$	
Operating Frequency	F_C	32K to 4MHz	CLK (RC osc)
		32K to 5MHz	XIN,XOUT (crystal osc)

DC ELECTRICAL CHARACTERISTICS ($V_{DD}=5\pm 0.5V$, $V_{SS}=0V$, $T_{OPR}=25^{\circ}C$)

Parameters	Sym.	Min.	Typ.	Max.	Unit	Conditions
Supply current	I_{DD}	-	0.7	2	mA	$V_{DD}=5.5V$, no load $F_c=4.19MHz$ (crystal osc)
		-	60	110	μA	$V_{DD}=5.5V$, no load sleep mode, low voltage reset enable
		-	0.1	1	μA	$V_{DD}=5.5V$, sleep mode, low voltage reset disable
Hysteresis voltage	V_{HYS+}	$0.50V_{DD}$	-	$0.75V_{DD}$	V	\overline{RESET} , P0, P8
	V_{HYS-}	$0.20V_{DD}$	-	$0.40V_{DD}$	V	
Input current	I_{IH}	-	-	± 1	μA	\overline{RESET} , P0, $V_{DD}=5.5V$, $V_{IH}=5.5/0V$
		-	-	± 1	μA	Open-drain: $V_{DD}=5.5V$, $V_{IH}=5.5/0V$
Output current (Port 1)	I_{OH}	5	-	-	mA	P1 normal source, $V_{DD}=4.5V$, $V_{OH}=3.5V$
		5	-	-	mA	P1 normal sink, $V_{DD}=4.5V$, $V_{OL}=1.0V$
						P1 high sink, $V_{DD}=4.5V$, $V_{OL}=1.0V$
Output voltage (Port 7 Port8)	V_{OH}	2.4	-	-	V	P7,P8 low source, $V_{DD}=4.5V$, $I_{OH}=-250\mu A$
		3.5	-	-	V	P7,P8 normal source, $V_{DD}=4.5V$, $I_{OH}=-5mA$
		3.0	-	-	V	P7,P8 high source, $V_{DD}=4.5V$, $I_{OH}=-20mA$
	V_{OL}	-	-	1	V	P7,P8 normal sink, $V_{DD}=4.5V$, $I_{OL}=5mA$
		-	-	1.5	V	P7,P8 high sink, $V_{DD}=4.5V$, $I_{OL}=20mA$
Leakage current	I_{OL}	-	-	1	μA	Open drain, $V_{DD}=5.5V$, $V_O=5.5V$
Input resistor	R_{IN}	30	90	150	K Ω	P0
		100	300	450	K Ω	\overline{RESET}
Frequency stability		-	10	-	%	$F_c=4MHz$, RC osc ($R=7.5k\Omega$, $C=20pF$) [$F_c=(4.5V)-F(3.6V)$]/ $F(4.5V)$
Frequency variation		-	20	-	%	$F_c=4MHz$, $V_{OL}=4.5V$, RC osc [$F(\text{typical})-F(\text{worse case})$]/ $F(\text{typical})$
Low voltage reset level		3.3	-	4.0	V	

* This specification are subject to be changed without notice.

Preliminary

RESET PIN TYPE

TYPE RESET-A

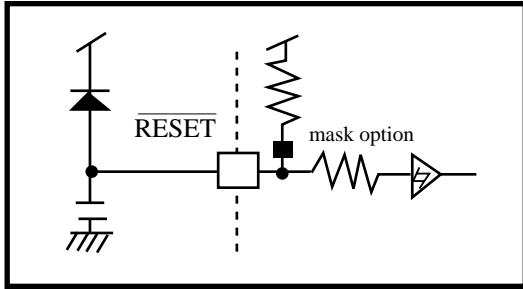

OSCILLATION PIN TYPE

TYPE OSC-A

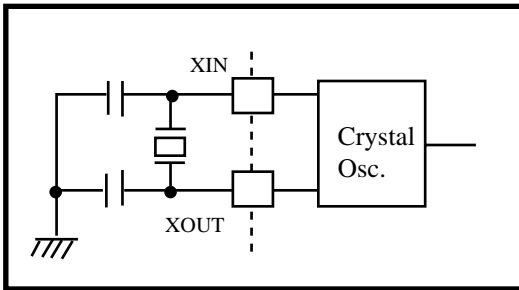

TYPE OSC-C

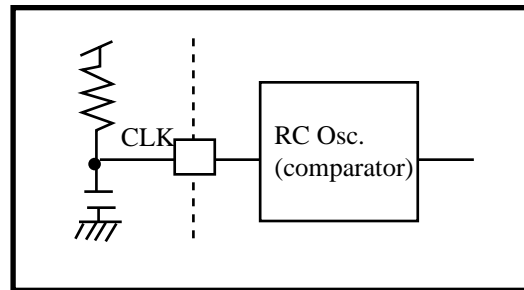

INPUT PIN TYPE

TYPE INPUT-A

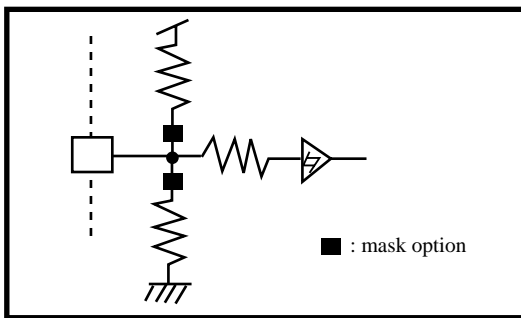

TYPE INPUT-C

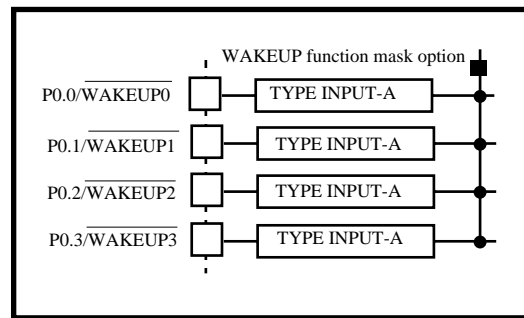

OUTPUT PIN TYPE

TYPE OUTPUT

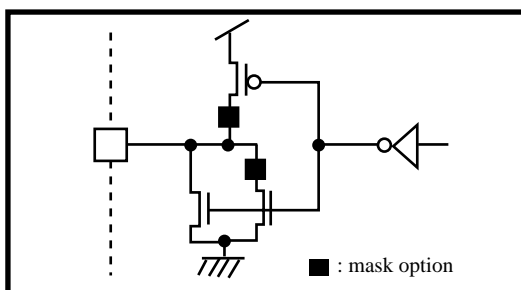

TYPE OUTPUT-C

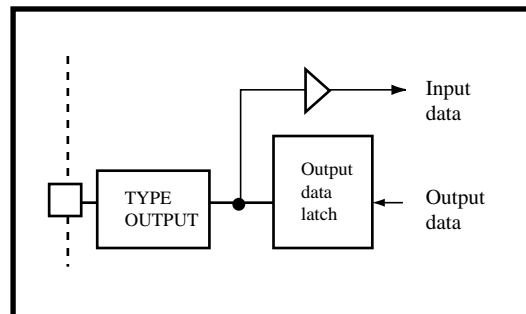

Preliminary

TYPE OUTPUT-B

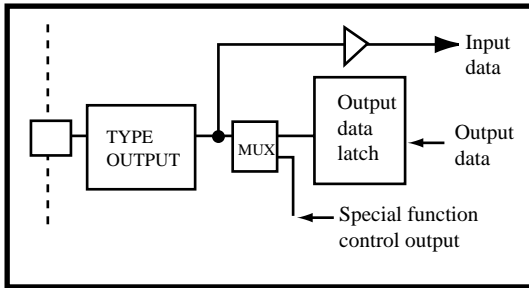

I/O PIN TYPE

TYPE I/O_T

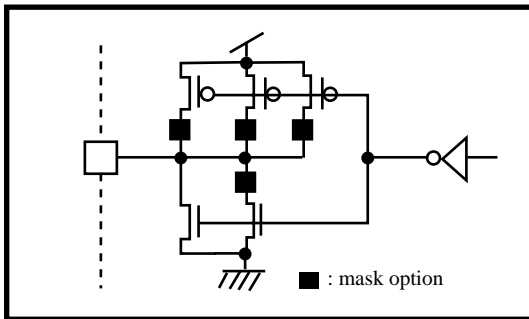

TYPE I/O-U

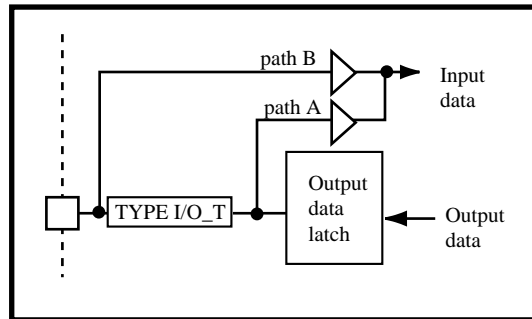

TYPE I/O-V

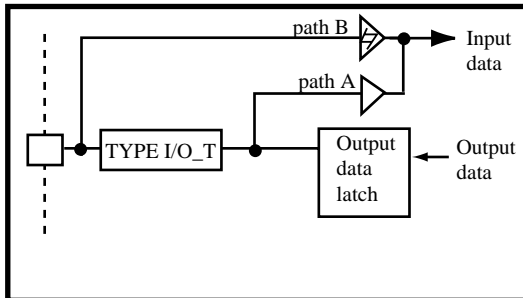

TYPE I/O-W

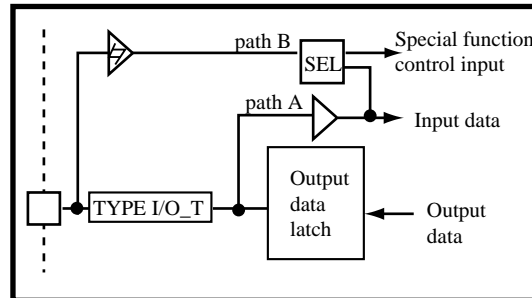

- Path A : For set and clear bit of port instructions, data goes through path A from output data latch to CPU.
- Path B : For input and test instructions, data from output pin go through path B to CPU and the output data latch will be set to high.

Preliminary

APPLICATION CIRCUIT

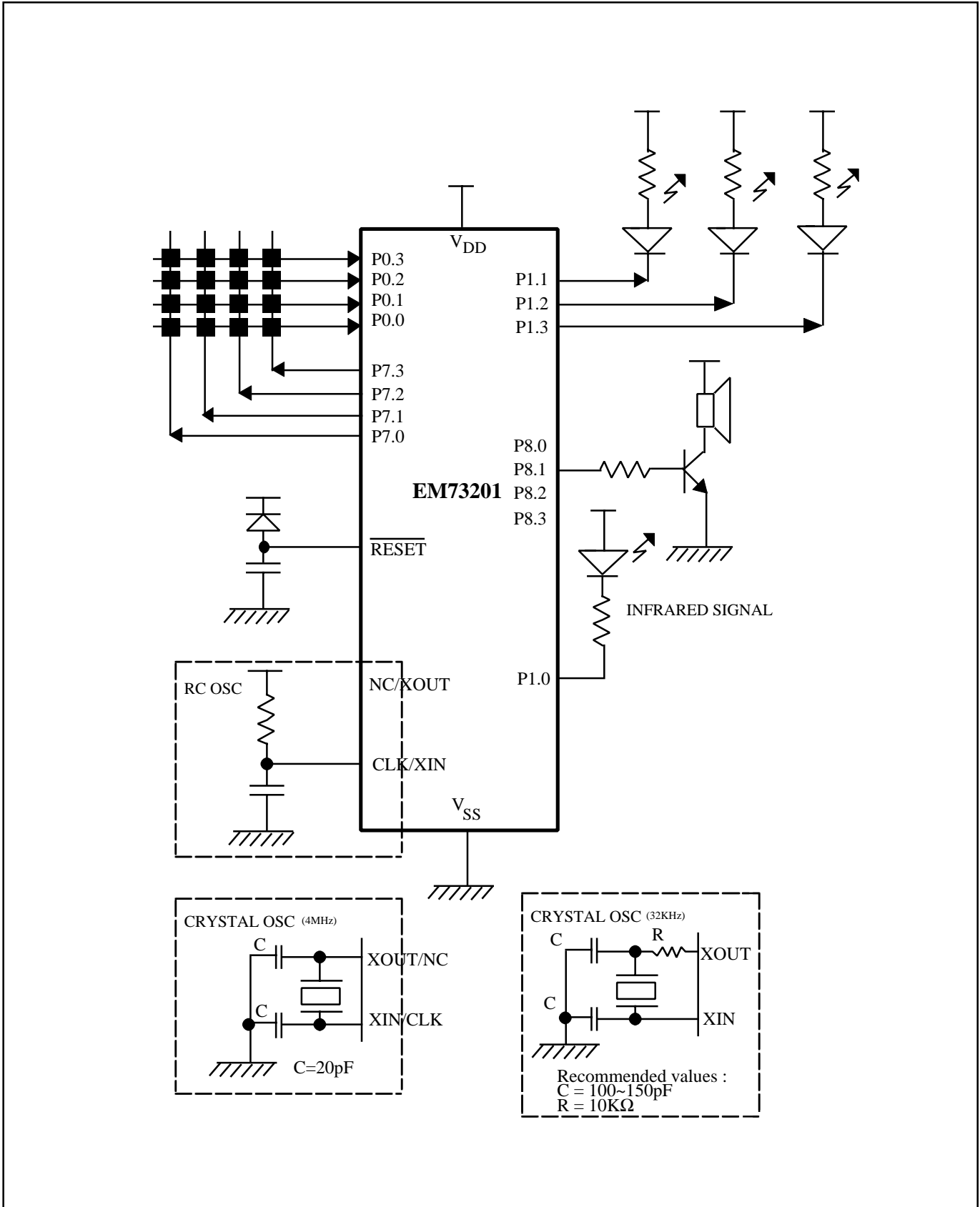

Preliminary

PAD DIAGRAM

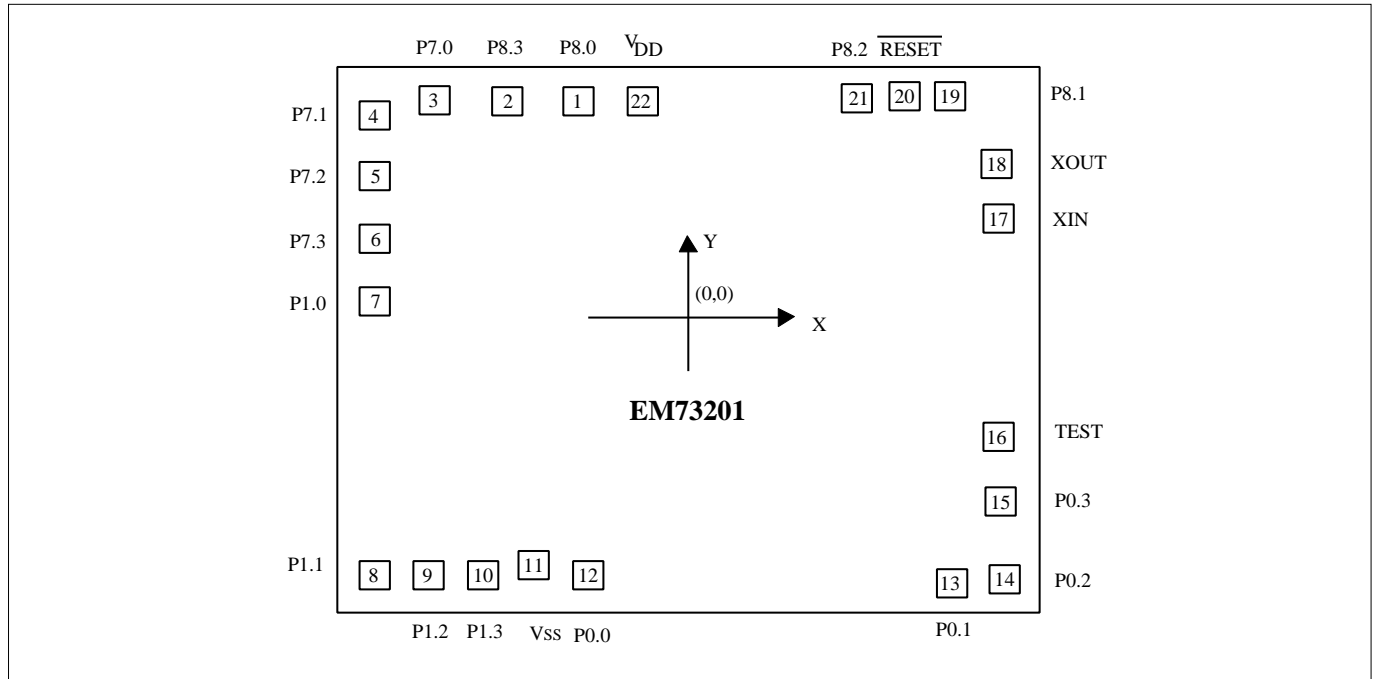

Chip Size : 1820 μm x 1510 μm

PadNo.	Symbol	X	Y
1	P8.0	-301.5	661.2
2	P8.3	-465.9	661.2
3	P7.0	-661.2	661.2
4	P7.1	-818.2	603.1
5	P7.2	-818.2	405.1
6	P7.3	-818.2	240.7
7	P1.0	-818.2	59.8
8	P1.1	-829.2	-650.5
9	P1.2	-706.2	-650.5
10	P1.3	-583.0	-650.5
11	V _{SS}	-457.4	-636.4
12	P0.0	-298.0	-651.4
13	P0.1	705.5	-651.4
14	P0.2	828.4	-651.4
15	P0.3	814.7	-454.3
16	TEST	814.7	-303.0
17	XIN	790.1	194.6
18	XOUT	790.1	374.5
19	P8.1	692.1	643.1
20	RESET	564.5	643.1
21	P8.2	433.8	643.1
22	V _{DD}	-123.2	661.2

Unit : μm

Note : For PCB layout, IC substrate must be floated, or connect to V_{SS} .

* This specification are subject to be changed without notice.

Preliminary

INSTRUCTION TABLE

(1) Data Transfer

Mnemonic	Object code (binary)	Operation description	Byte	Cycle	Flag		
					C	Z	S
LDA x	0110 1010 xxxx xxxx	Acc←RAM[x]	2	2	-	Z	1
LDAM	0101 1010	Acc ←RAM[HL]	1	1	-	Z	1
LDAX	0110 0101	Acc←ROM[DP] _L	1	2	-	Z	1
LDAXI	0110 0111	Acc←ROM[DP] _H ,DP+1	1	2	-	Z	1
LDH #k	1001 kkkk	HR←k	1	1	-	-	1
LDHL x	0100 1110 xxxx xx00	LR←RAM[x],HR←RAM[x+1]	2	2	-	-	1
LDIA #k	1101 kkkk	Acc←k	1	1	-	Z	1
LDL #k	1000 kkkk	LR←k	1	1	-	-	1
STA x	0110 1001 xxxx xxxx	RAM[x]←Acc	2	2	-	-	1
STAM	0101 1001	RAM[HL]←Acc	1	1	-	-	1
STAMD	0111 1101	RAM[HL]←Acc, LR-1	1	1	-	Z	C
STAMI	0111 1111	RAM[HL]←Acc, LR+1	1	1	-	Z	C'
STD #k,y	0100 1000 kkkk yyyy	RAM[y]←k	2	2	-	-	1
STDMI #k	1010 kkkk	RAM[HL]←k, LR+1	1	1	-	Z	C'
THA	0111 0110	Acc←HR	1	1	-	Z	1
TLA	0111 0100	Acc←LR	1	1	-	Z	1

(2) Rotate

Mnemonic	Object code (binary)	Operation description	Byte	Cycle	Flag		
					C	Z	S
RLCA	0101 0000	←CF←Acc←←	1	1	C	Z	C'
RRCA	0101 0001	↗CF→Acc→	1	1	C	Z	C'

(3) Arithmetic operation

Mnemonic	Object code (binary)	Operation description	Byte	Cycle	Flag		
					C	Z	S
ADCAM	0111 0000	Acc←Acc + RAM[HL] + CF	1	1	C	Z	C'
ADD #k,y	0100 1001 kkkk yyyy	RAM[y]←RAM[y] +k	2	2	-	Z	C'
ADDA #k	0110 1110 0101 kkkk	Acc←Acc+k	2	2	-	Z	C'
ADDAM	0111 0001	Acc←Acc + RAM[HL]	1	1	-	Z	C'
ADDH #k	0110 1110 1001 kkkk	HR←HR+k	2	2	-	Z	C'
ADDL #k	0110 1110 0001 kkkk	LR←LR+k	2	2	-	Z	C'
ADDM #k	0110 1110 1101 kkkk	RAM[HL]←RAM[HL] +k	2	2	-	Z	C'
DECA	0101 1100	Acc←Acc-1	1	1	-	Z	C
DECL	0111 1100	LR←LR-1	1	1	-	Z	C
DECM	0101 1101	RAM[HL]←RAM[HL] -1	1	1	-	Z	C
INCA	0101 1110	Acc←Acc + 1	1	1	-	Z	C'

Preliminary

INCL	0111 1110	LR←LR + 1	1	1	-	Z	C'
INCM	0101 1111	RAM[HL]←RAM[HL]+1	1	1	-	Z	C'
SUBA #k	0110 1110 0111 kkkk	Acc←k-Acc	2	2	-	Z	C
SBCAM	0111 0010	Acc←RAM[HL] - Acc - CF'	1	1	C	Z	C
SUBM #k	0110 1110 1111 kkkk	RAM[HL]←k - RAM[HL]	2	2	-	Z	C

(4) Logical operation

Mnemonic	Object code (binary)	Operation description	Byte	Cycle	Flag		
					C	Z	S
ANDA #k	0110 1110 0110 kkkk	Acc←Acc&k	2	2	-	Z	Z'
ANDAM	0111 1011	Acc←Acc & RAM[HL]	1	1	-	Z	Z'
ANDM #k	0110 1110 1110 kkkk	RAM[HL]←RAM[HL]&k	2	2	-	Z	Z'
ORA #k	0110 1110 0100 kkkk	Acc←Acc k	2	2	-	Z	Z'
ORAM	0111 1000	Acc ←Acc RAM[HL]	1	1	-	Z	Z'
ORM #k	0110 1110 1100 kkkk	RAM[HL]←RAM[HL] k	2	2	-	Z	Z'
XORAM	0111 1001	Acc←Acc^RAM[HL]	1	1	-	Z	Z'

(5) Exchange

Mnemonic	Object code (binary)	Operation description	Byte	Cycle	Flag		
					C	Z	S
EXA x	0110 1000 xxxx xxxx	Acc↔RAM[x]	2	2	-	Z	1
EXAH	0110 0110	Acc↔HR	1	2	-	Z	1
EXAL	0110 0100	Acc↔LR	1	2	-	Z	1
EXAM	0101 1000	Acc↔RAM[HL]	1	1	-	Z	1
EXHL x	0100 1100 xxxx xx00	LR↔RAM[x], HR↔RAM[x+1]	2	2	-	-	1

(6) Branch

Mnemonic	Object code (binary)	Operation description	Byte	Cycle	Flag		
					C	Z	S
SBR a	00aa aaaa	If SF=1 then PC←PC ₁₁₋₆ .a ₅₋₀ else null	1	1	-	-	1
LBR a	1100 aaaa aaaa aaaa	If SF= 1 then PC←a else null	2	2	-	-	1

(7) Compare

Mnemonic	Object code (binary)	Operation description	Byte	Cycle	Flag		
					C	Z	S
CMP #k,y	0100 1011 kkkk yyyy	k-RAM[y]	2	2	C	Z	Z'
CMPA x	0110 1011 xxxx xxxx	RAM[x]-Acc	2	2	C	Z	Z'
CMPAM	0111 0011	RAM[HL] - Acc	1	1	C	Z	Z'
CMPH #k	0110 1110 1011 kkkk	k - HR	2	2	-	Z	C
CMPIA #k	1011 kkkk	k - Acc	1	1	C	Z	Z'
CMPL #k	0110 1110 0011 kkkk	k-LR	2	2	-	Z	C

Preliminary

(8) Bit manipulation

Mnemonic	Object code (binary)	Operation description	Byte	Cycle	Flag		
					C	Z	S
CLM b	1111 00bb	RAM[HL] _b ←0	1	1	-	-	1
CLP p,b	0110 1101 11bb pppp	PORT[p] _b ←0	2	2	-	-	1
CLPL	0110 0000	PORT[LR ₃₋₂ +4]LR ₁₋₀ ←0	1	2	-	-	1
CLR y,b	0110 1100 11bb yyyy	RAM[y] _b ←0	2	2	-	-	1
SEM b	1111 01bb	RAM[HL] _b ←1	1	1	-	-	1
SEP p,b	0110 1101 01bb pppp	PORT[p] _b ←1	2	2	-	-	1
SEPL	0110 0010	PORT[LR ₃₋₂ +4]LR ₁₋₀ ←1	1	2	-	-	1
SET y,b	0110 1100 01bb yyyy	RAM[y] _b ←1	2	2	-	-	1
TF y,b	0110 1100 00bb yyyy	SF←RAM[y] _b '	2	2	-	-	*
TFA b	1111 10bb	SF←Acc _b '	1	1	-	-	*
TFM b	1111 11bb	SF←RAM[HL] _b '	1	1	-	-	*
TFP p,b	0110 1101 00bb pppp	SF←PORT[p] _b '	2	2	-	-	*
TFPL	0110 0001	SF←PORT[LR ₃₋₂ +4]LR ₁₋₀ '	1	2	-	-	*
TT y,b	0110 1100 10bb yyyy	SF←RAM[y] _b	2	2	-	-	*
TTP p,b	0110 1101 10bb pppp	SF←PORT[p] _b	2	2	-	-	*

(9) Subroutine

Mnemonic	Object code (binary)	Operation description	Byte	Cycle	Flag		
					C	Z	S
LCALL a	0100 0aaa aaaa aaaa	STACK[SP]←PC, SP←SP -1, PC←a	2	2	-	-	-
SCALL a	1110 mnn	STACK[SP]←PC, SP←SP - 1, PC←a, a = 8n +6 (n=1~15),0086h (n=0)	1	2	-	-	-
RET	0100 1111	SP←SP + 1, PC←STACK[SP]	1	2	-	-	-

(10) Input/output

Mnemonic	Object code (binary)	Operation description	Byte	Cycle	Flag		
					C	Z	S
INA p	0110 1111 0100 pppp	Acc←PORT[p]	2	2	-	Z	Z'
INM p	0110 1111 1100 pppp	RAM[HL]←PORT[p]	2	2	-	-	Z'
OUT #k,p	0100 1010 kkkk pppp	PORT[p]←k	2	2	-	-	1
OUTA p	0110 1111 000p pppp	PORT[p]←Acc	2	2	-	-	1
OUTM p	0110 1111 100p pppp	PORT[p]←RAM[HL]	2	2	-	-	1

(11) Flag manipulation

Mnemonic	Object code (binary)	Operation description	Byte	Cycle	Flag		
					C	Z	S
CGF	0101 0111	GF←0	1	1	-	-	1
SGF	0101 0101	GF←1	1	1	-	-	1
TFCFC	0101 0011	SF←CF', CF←0	1	1	0	-	*

Preliminary

TGS	0101 0100	SF←GF	1	1	-	-	*
TTCFS	0101 0010	SF←CF, CF←1	1	1	1	-	*
TZS	0101 1011	SF←ZF	1	1	-	-	*

(12) Interrupt control

Mnemonic	Object code (binary)	Operation description	Byte	Cycle	Flag		
					C	Z	S
CIL r	0110 0011 11rr rrrr	IL←IL & r	2	2	-	-	1
DICIL r	0110 0011 10rr rrrr	EIF←0,IL←IL&r	2	2	-	-	1
EICIL r	0110 0011 01rr rrrr	EIF←1,IL←IL&r	2	2	-	-	1
EXAE	0111 0101	MASK↔Acc	1	1	-	-	1
RTI	0100 1101	SP←SP+1,FLAG.PC ←STACK[SP],EIF ←1	1	2	*	*	*

(13) CPU control

Mnemonic	Object code (binary)	Operation description	Byte	Cycle	Flag		
					C	Z	S
NOP	0101 0110	no operation	1	1	-	-	-

(14) Timer/Counter & Data pointer & Stack pointer control

Mnemonic	Object code (binary)	Operation description	Byte	Cycle	Flag		
					C	Z	S
LDADPL	0110 1010 1111 1100	Acc←[DP] _L	2	2	-	Z	1
LDADPM	0110 1010 1111 1101	Acc←[DP] _M	2	2	-	Z	1
LDADPH	0110 1010 1111 1110	Acc←[DP] _H	2	2	-	Z	1
LDASP	0110 1010 1111 1111	Acc←SP	2	2	-	Z	1
LDATAL	0110 1010 1111 0100	Acc←[TA] _L	2	2	-	Z	1
LDATAM	0110 1010 1111 0101	Acc←[TA] _M	2	2	-	Z	1
LDATAH	0110 1010 1111 0110	Acc←[TA] _H	2	2	-	Z	1
LDATBL	0110 1010 1111 1000	Acc←[TB] _L	2	2	-	Z	1
LDATBM	0110 1010 1111 1001	Acc←[TB] _M	2	2	-	Z	1
LDATBH	0110 1010 1111 1010	Acc←[TB] _H	2	2	-	Z	1
STADPL	0110 1001 1111 1100	[DP] _L ←Acc	2	2	-	-	1
STADPM	0110 1001 1111 1101	[DP] _M ←Acc	2	2	-	-	1
STADPH	0110 1001 1111 1110	[DP] _H ←Acc	2	2	-	-	1
STASP	0110 1001 1111 1111	SP←Acc	2	2	-	-	1
STATAL	0110 1001 1111 0100	[TA] _L ←Acc	2	2	-	-	1
STATAM	0110 1001 1111 0101	[TA] _M ←Acc	2	2	-	-	1
STATAH	0110 1001 1111 0110	[TA] _H ←Acc	2	2	-	-	1
STATBL	0110 1001 1111 1000	[TB] _L ←Acc	2	2	-	-	1
STATBM	0110 1001 1111 1001	[TB] _M ←Acc	2	2	-	-	1
STATBH	0110 1001 1111 1010	[TB] _H ←Acc	2	2	-	-	1

Preliminary

**** SYMBOL DESCRIPTION

Symbol	Description	Symbol	Description
HR	H register	LR	L register
PC	Program counter	DP	Data pointer
SP	Stack pointer	STACK[SP]	Stack specified by SP
A _{CC}	Accumulator	FLAG	All flags
CF	Carry flag	ZF	Zero flag
SF	Status flag	GF	General flag
EI	Enable interrupt register	IL	Interrupt latch
MASK	Interrupt mask	PORT[p]	Port (address : p)
TA	Timer/counter A	TB	Timer/counter B
RAM[HL]	Data memory (address : HL)	RAM[x]	Data memory (address : x)
ROM[DP] _L	Low 4-bit of program memory	ROM[DP] _H	High 4-bit of program memory
[DP] _L	Low 4-bit of data pointer register	[DP] _M	Middle 4-bit of data pointer register
[DP] _H	High 4-bit of data pointer register	[TA] _L ([TB] _L)	Low 4-bit of timer/counter A (timer/counter B) register
[TA] _M ([TB] _M)	Middle 4-bit of timer/counter A (timer/counter B) register	[TA] _H ([TB] _H)	High 4-bit of timer/counter A (timer/counter B) register
←	Transfer	↔	Exchange
+	Addition	-	Substraction
&	Logic AND		Logic OR
^	Logic XOR	!	Inverse operation
.	Concatenation	#k	4-bit immediate data
x	8-bit RAM address	y	4-bit zero-page address
p	4-bit or 5-bit port address	b	Bit address
r	6-bit interrupt latch	PC ₁₁₋₆	Bit 11 to 6 of program counter
LR ₁₋₀	Contents of bit assigned by bit 1 to 0 of LR	a ₅₋₀	Bit 5 to 0 of destination address for branch instruction
LR ₃₋₂	Bit 3 to 2 of LR		