



Design Example Report

Title	<i>1.6W Dual Output Flyback Converter using LNK304P</i>
Specification	Input: 85-265VAC Output: 15V / 25mA (non-isolated) and 12V / 100mA (isolated)
Application	Motor Control
Author	Power Integrations Applications Department
Document Number	DER-48
Date	April 20, 2005
Revision	1.0

Summary and Features

- Dual output design provides non-isolated and isolated (Class II) output
- 17 components including EMI filter
- Loop Fault Protection
- Short Circuit Protection
- Hysteretic Thermal Shutdown
- Non-isolated Output is Referenced to Neutral
- Precise Output Voltage control
- Frequency Jitter
- Excellent Conducted EMI (>10dB margin across spectrum)
- Extremely low standby power consumption (<100mW!)

The products and applications illustrated herein (including circuits external to the products and transformer construction) may be covered by one or more U.S. and foreign patents or potentially by pending U.S. and foreign patent applications assigned to Power Integrations. A complete list of Power Integrations' patents may be found at www.powerint.com.

Table Of Contents

1	Introduction.....	3
2	Power Supply Specification.....	4
3	Schematic.....	5
4	Circuit Description	6
5	PCB Layout	7
6	Bill Of Materials	8
7	Transformer Specification.....	9
7.1	Electrical Diagram	9
7.2	Electrical Specifications.....	9
7.3	Materials.....	9
7.4	Transformer Build Diagram	10
7.5	Transformer Construction.....	10
7.6	Design Notes.....	11
8	Transformer Spreadsheets.....	12
9	Performance Data	13
9.1	Cross-Regulation Data	13
9.2	No-load Input Power and Efficiency	14
9.3	Regulation	15
9.3.1	Line and Load Regulation	15
10	Waveforms.....	16
10.1	Drain Voltage and Current, Normal Operation	16
10.2	Output Voltage Start-up Profile	16
10.3	Drain Voltage and Current Start-up Profile.....	17
10.4	Load Transient Response (50% to 100% Load Step)	17
10.5	Output Ripple Measurements.....	18
10.5.1	Ripple Measurement Technique	18
10.5.2	Measurement Results	19
11	Conducted EMI	20
12	Revision History.....	21

Important Note:

Although this board is designed to satisfy safety isolation requirements, the engineering prototype has not been agency approved. Therefore, all testing should be performed using an isolation transformer to provide the AC input to the prototype board.

Design Reports contain a power supply design specification, schematic, bill of materials, and transformer documentation. Performance data and typical operation characteristics are included. Typically only a single prototype has been built.



1 Introduction

This document is an engineering prototype report describing a universal input dual output Flyback converter providing an isolated and non-isolated output voltage for a motor application employing the LNK304P.

The document contains the power supply specification, schematic, bill-of-materials, transformer documentation, printed circuit layout, and performance data.

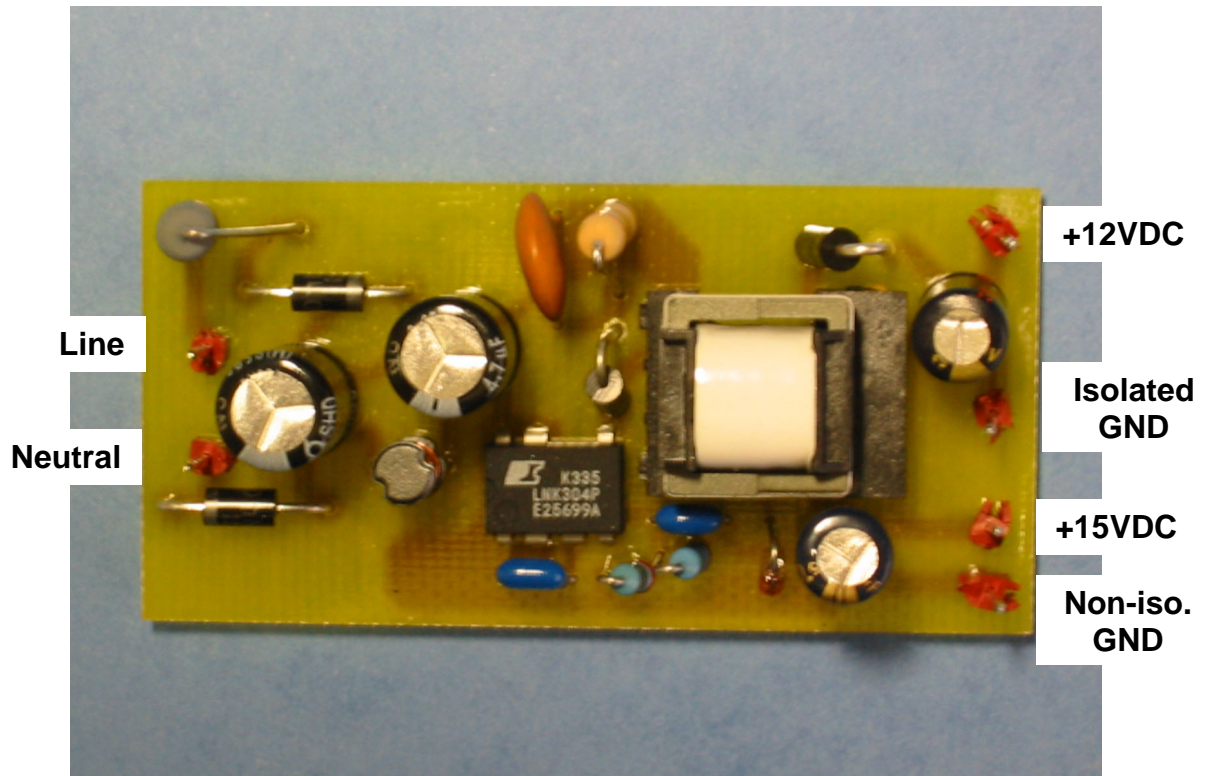

Figure 1 – Populated Circuit Board Photograph.

2 Power Supply Specification

Description	Symbol	Min	Typ	Max	Units	Comment
Input						
Voltage	V_{IN}	85		265	VAC	2 Wire – no P.E.
Frequency	f_{LINE}	47	50/60	64	Hz	
No-load Input Power (230 VAC)				0.1	W	
Output						
Output Voltage 1	V_{OUT1}	13.50	15	16.50	V	± 10% 20 MHz Bandwidth
Output Ripple Voltage 1	$V_{RIPPLE1}$			50	mV	
Output Current 1	I_{OUT1}	5		25	mA	
Output Voltage 2	V_{OUT1}	9.00	12	15.00	V	± 25% 20 MHz Bandwidth
Output Ripple Voltage 2	$V_{RIPPLE1}$			100	mV	
Output Current 2	I_{OUT1}	10		100	mA	
Total Output Power						
Continuous Output Power	P_{OUT}			1.6	W	
Efficiency	η	74			%	Measured at P_{OUT} (1.6 W), 25 °C
Environmental						
Conducted EMI			Meets CISPR22B / EN55022B			1.2/50 μ s surge, IEC 1000-4-5, Series Impedance: Differential Mode: 2 Ω Common Mode: 12 Ω
Safety			Designed to meet IEC950, UL1950 Class II			
Surge		4			kV	
Surge		3			kV	100 kHz ring wave, 500 A short circuit current, differential and common mode
Ambient Temperature	T_{AMB}	0		50	°C	Free convection, sea level



3 Schematic

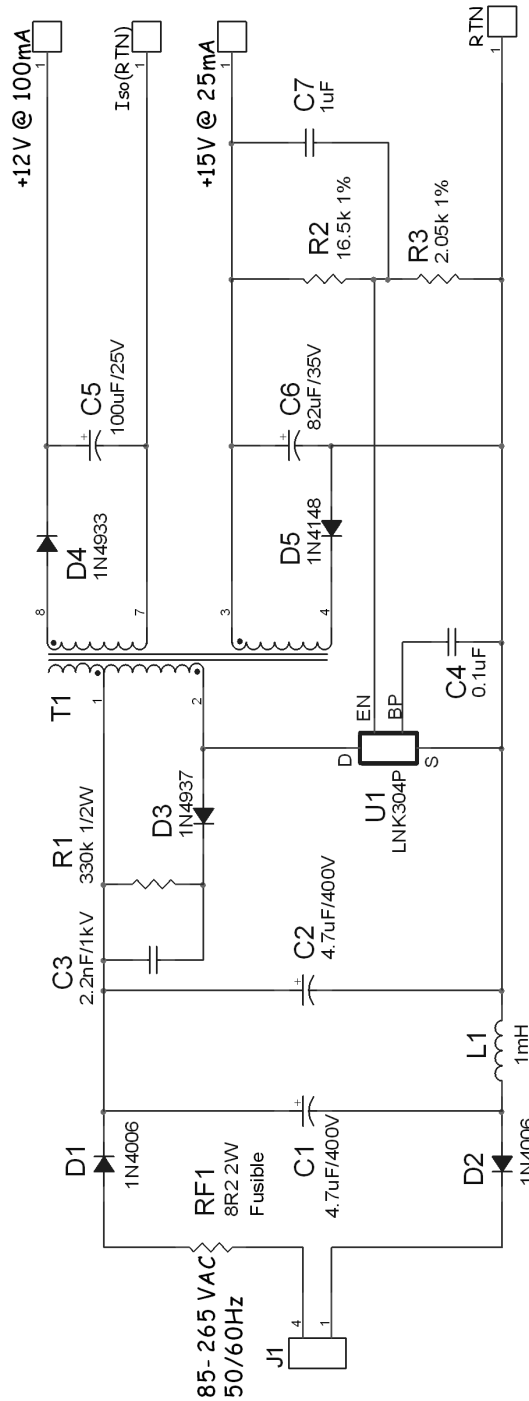

Figure 2 – Schematic.



4 Circuit Description

In this motor control application, the AC input is half-wave rectified and filtered by D1, C1 and C2 to create a high voltage DC bus that is connected to T1. Inductor L1 forms a pi-filter in conjunction with C1 and C2. The frequency jitter in LNK304 allows the unit to meet worldwide conducted EMI standards using a simple pi-filter. C3, R1 and D3 form a clamp circuit that limits the turn-off voltage spike to a safe level on the LNK304 DRAIN pin. C4 is a VCC storage capacitor for U1.

The isolated secondary winding is rectified and filtered by D4 and C5 to give the 12VDC output. The non-isolated output is rectified and filtered by D5 and C6. The potential divider formed by R2 and R3 determines the 15VDC output voltage. Capacitor C7 acts to monotonically increase the output voltages at start-up.

The transformer is wound using the ESHIELD™ winding technique to help reduce the common-mode noise generated by the transformer windings and help improve conducted EMI performance.



5 PCB Layout

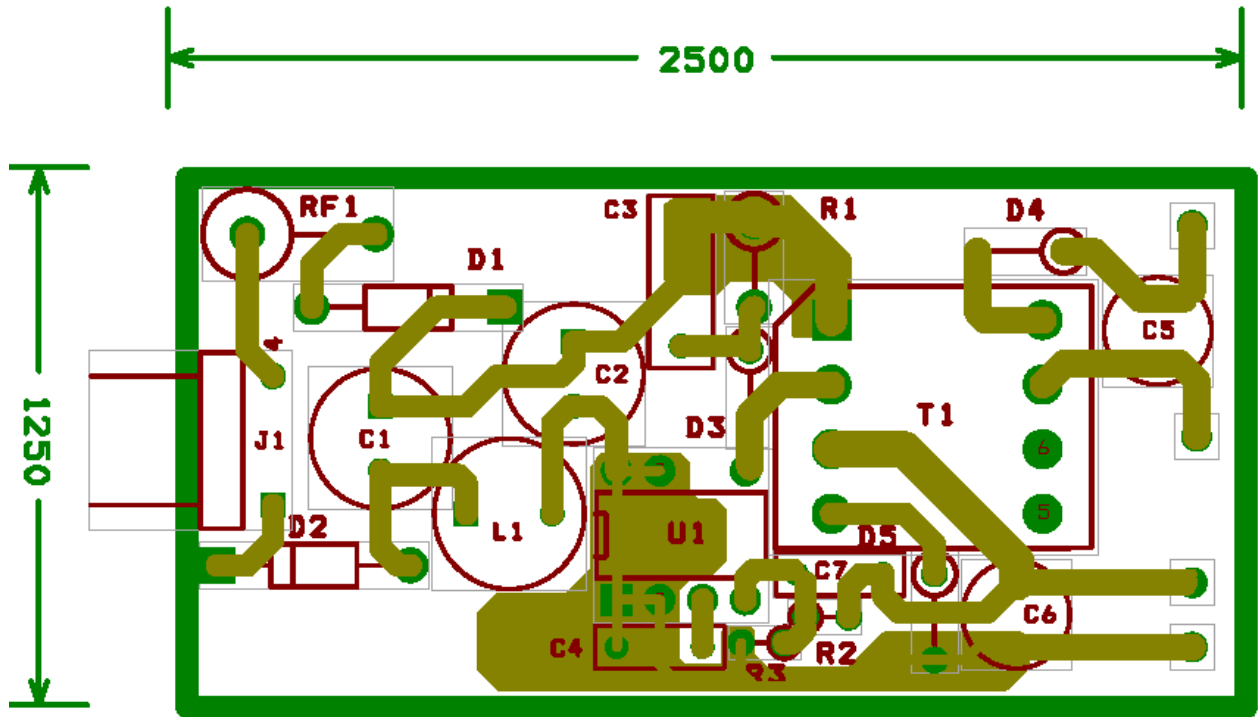

Figure 3 – Printed Circuit Layout.



6 Bill Of Materials

Item	Qty	Reference	Description	P/N	Manufacturer
1	1	U1	<i>LNK-TN Switch</i>	LNK304P	Power Integrations
2	2	C1, C2	4.7uF/400V		
3	1	C3	2200pF/1kV		
4	1	C4	0.1uF/50V		
5	1	C5	100uF/25V		
6	1	C6	82uF/35V		
7	1	C7	1uF/50V		
8	1	RF1	8R2 1W Fusible		
9	1	R1	330k 1/2W		
10	1	R2	16.5k 1%		
11	1	R3	2.05k 1%		
12	2	D1, D2	Standard Rec. 1A/800V	1N4006	
13	1	D3	Fast Rec. 1A/1000V	1N4937	
14	1	D4	Fast Rec. 1A/200V	1N4933	
15	1	D5	Switching Diode	1N4148	
16	1	L1	1mH/250mA		
17	1	T1	EE13 Transformer (custom)		



7 Transformer Specification

7.1 Electrical Diagram

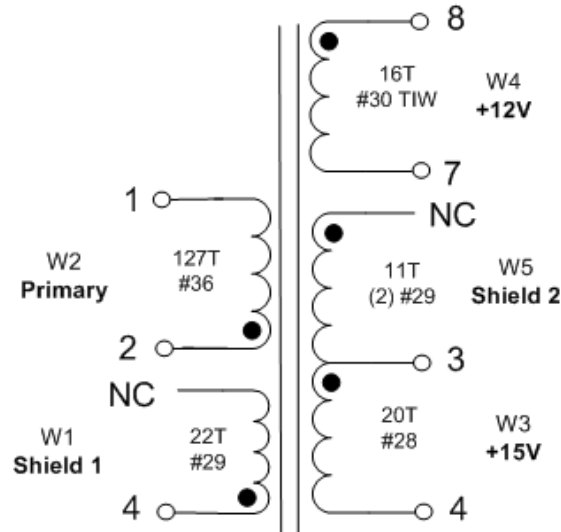

Figure 4 –Transformer Electrical Diagram

7.2 Electrical Specifications

Electrical Strength	60Hz 1minute, from Pins 1-4 to Pins 7-8	N/A
Primary Inductance (Pin 1 to Pin 2)	All windings open	1.8mH +/- 10%
Resonant Frequency	All windings open	500 kHz min.
Primary Leakage Inductance	L ₁₂ with pins 7-8 shorted	100µH max.

7.3 Materials

Item	Description
[1]	Core: EE13, TDK Gapped for $A_L = 111 \text{ nH/T}^2$
[2]	Bobbin: Horizontal 8 pins
[3]	Magnet Wire: #36 AWG
[4]	Magnet Wire: #28 AWG
[5]	Magnet Wire: #29 AWG
[6]	Magnet Wire: #30 TIW
[7]	Tape: 3M 1298 Polyester Film (white) 0.311" x 2 mils
[8]	Varnish

7.4 Transformer Build Diagram

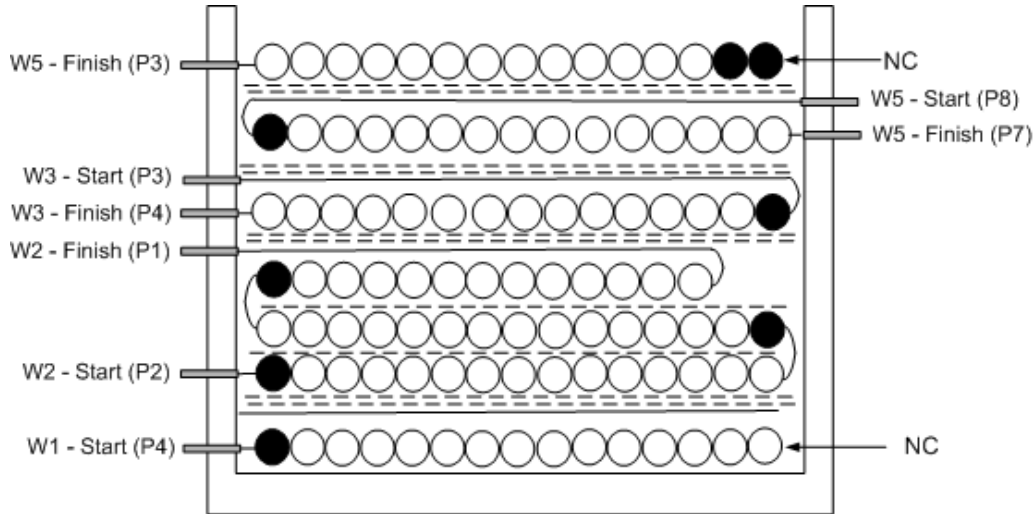

Figure 5 – Transformer Build Diagram.

7.5 Transformer Construction

Place the bobbin on the winding machine with pins 1-4 on the right side and pins 5-8 on the left side.

W1 (Bias/Core Cancellation Winding)	Wind 22 turns of #29AWG in a single uniform layer, starting at pin 4 and leaving finish end unterminated.
Insulation	Add 2 layers of tape [7] for insulation.
W2 (Primary Winding)	Start at pin 2 with #36AWG and wind 42 turns, apply a layer of tape [7] and continue on the second layer with 42 turns, apply a layer of tape [7] and wind an additional 43 turns on the third and final layer. Finish winding on pin 1.
Insulation	Add 2 layer of tape [7] for insulation.
W3 (+15V)	Starting at pin 3 wind 20 turns uniformly across entire bobbin window with #28AWG, finish on pin 4.
Insulation	Add 2 layers of tape [7] for insulation.
W4 (+12V)	Starting at pin 8 wind 16 turns uniformly across entire bobbin window with #30 T.I.W., finish on pin 7.
Insulation	Add 2 layers of tape [7] for insulation.
W5 (Shield)	Wind 11 bifilar turns of #29AWG in a single uniform layer, starting temporarily on pin 6 and finishing on pin 3.
Outer Insulation	Add 3 layers of tape [7] for insulation.
Final Assembly	Use guidelines specified in AN-24 for audio noise suppression techniques in the transformer construction.



7.6 Design Notes

Power Integrations Device	LNK304P
Frequency of Operation	66 KHz
Mode	Discontinuous
Peak Current	0.23 A
Reflected Voltage (Secondary to Primary)	100V
Maximum AC Input Voltage	265 V



8 Transformer Spreadsheets

Rev 1.0 INPUT OUTPUT **TinySwitch-II_022001.xls: TINYSwitch-II Continuous/Discontinuous Flyback Transformer Design Spreadsheet**
Dual Output LNK304 Flyback

Rev 1.0	INPUT	OUTPUT	
ENTER APPLICATION VARIABLES			
VACMIN	85	Volts	Minimum AC Input Voltage
VACMAX	265	Volts	Maximum AC Input Voltage
fL	50	Hertz	AC Mains Frequency
VO	15	Volts	Output Voltage
PO	1.575	Watts	Output Power
n	0.6		Efficiency Estimate
Z	0.5		Loss Allocation Factor
VB	12	Volts	Bias Voltage
tC	3	mSeconds	Bridge Rectifier Conduction Time Estimate
CIN	4.7	uFarads	Input Filter Capacitor

ENTER TinySwitch-II VARIABLES

TNY-II	Ink304	Universal	115/230V
Chosen Device	LNK304	Power Out	5.5W 8W
ILIMITMIN		0.233	Amps
ILIMITMAX		0.267	Amps
fS	66000		Hertz
fSmin		57000	Hertz
fSmax		74000	Hertz
VOR	100		Volts
VDS	10		Volts
VD	0.7		Volts
VDB	0.7		Volts
KP	3.00		

ENTER TRANSFORMER CORE/CONSTRUCTION VARIABLES

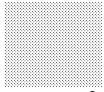
Core Type	ee13			
Core		#N/A	P/N:	#N/A
Bobbin		#N/A	P/N:	#N/A
AE		0.171	cm^2	Core Effective Cross Sectional Area
LE		3.02	cm	Core Effective Path Length
AL		1130	nH/T^2	Ungapped Core Effective Inductance
BW		7.4	mm	Bobbin Physical Winding Width
M	0		mm	Safety Margin Width (Half the Primary to Secondary Creepage Distance)
L	3			Number of Primary Layers
NS	20			Number of Secondary Turns

DC INPUT VOLTAGE PARAMETERS

VMIN	81	Volts	Minimum DC Input Voltage
VMAX	375	Volts	Maximum DC Input Voltage

CURRENT WAVEFORM SHAPE PARAMETERS

DMAX	0.32		Maximum Duty Cycle
Iavg	0.03	Amps	Average Primary Current
IP	0.20	Amps	Peak Primary Current
IP Effective	0.20		
IP Actual	0.233		Actual IP figure = Device I_LIMIT
fSact			Actual Effective Switching Frequency
IR	0.20	Amps	Primary Ripple Current
IRMS	0.07	Amps	Primary RMS Current

TRANSFORMER PRIMARY DESIGN PARAMETERS

LP		1795	uHenries	Primary Inductance
NP		127		Primary Winding Number of Turns
NB		16		Bias Winding Number of Turns
ALG	111		nH/T^2	Gapped Core Effective Inductance
BM		1669	Gauss	Maximum Flux Density at PO, VMIN (BM<3000)
BP		2200	Gauss	Peak Flux Density (BP<4200)
BAC	835		Gauss	AC Flux Density for Core Loss Curves (0.5 X Peak to Peak)
ur	1588			Relative Permeability of Ungapped Core
LG		0.18	mm	Gap Length (Lg > 0.1 mm)
BWE	22.2		mm	Effective Bobbin Width
OD		0.17	mm	Maximum Primary Wire Diameter including insulation
INS	0.04		mm	Estimated Total Insulation Thickness (= 2 * film thickness)
DIA		0.14	mm	Bare conductor diameter
AWG		36	AWG	Primary Wire Gauge (Rounded to next smaller standard AWG value)
CM	25		Cmils	Bare conductor effective area in circular mils
CMA		385	Cmils/Amp	Primary Winding Current Capacity (200 < CMA < 500)

TRANSFORMER SECONDARY DESIGN PARAMETERS (SINGLE OUTPUT / SINGLE OUTPUT EQUIVALENT)



9 Performance Data

All measurements performed at room temperature, 60 Hz input frequency.

9.1 Cross-Regulation Data

Vin = 85VAC										
	No Load		I		II		III		IV	
	+15V	15.94	6.3%	15.95	6.3%	15.88	5.9%	16.08	7.2%	15.87
+12V	13.12	9.3%	12.33	2.8%	11.58	-3.5%	13.69	14.1%	9.20	-23.3%
Pin	0.05		0.32		2.11		0.70		1.45	
Eff	0.0%		63.5%		73.7%		77.0%		68.8%	
Vin = 120VAC										
	No Load		I		II		III		IV	
	+15V	15.95	6.3%	15.96	6.4%	15.94	6.3%	16.04	6.9%	15.88
+12V	13.46	12.2%	12.37	3.1%	11.63	-3.1%	12.97	8.1%	9.21	-23.3%
Pin	0.07		0.33		2.09		0.72		1.47	
Eff	0.0%		62.6%		74.8%		73.5%		68.1%	
Vin = 240VAC										
	No Load		I		II		III		IV	
	+15V	16.01	6.7%	15.97	6.5%	15.93	6.2%	16.07	7.1%	15.89
+12V	12.65	5.4%	12.37	3.1%	11.63	-3.1%	13.01	8.4%	9.33	-22.3%
Pin	0.09		0.38		2.38		0.81		1.65	
Eff	0.0%		53.6%		65.5%		65.7%		61.4%	
Vin = 265VAC										
	No Load		I		II		III		IV	
	+15V	16.00	6.7%	15.97	6.5%	15.92	6.1%	16.07	7.1%	15.88
+12V	12.64	5.3%	12.37	3.1%	11.64	-3.0%	13.02	8.5%	9.34	-22.2%
Pin	0.96		0.39		2.41		0.82		1.68	
Eff	0.0%		52.2%		64.8%		64.9%		60.3%	

Load Current (ADC)		
	+15V	+12V
	0	0
I	0.005	0.01
II	0.025	0.1
III	0.025	0.01
IV	0.005	0.1



9.2 No-load Input Power and Efficiency

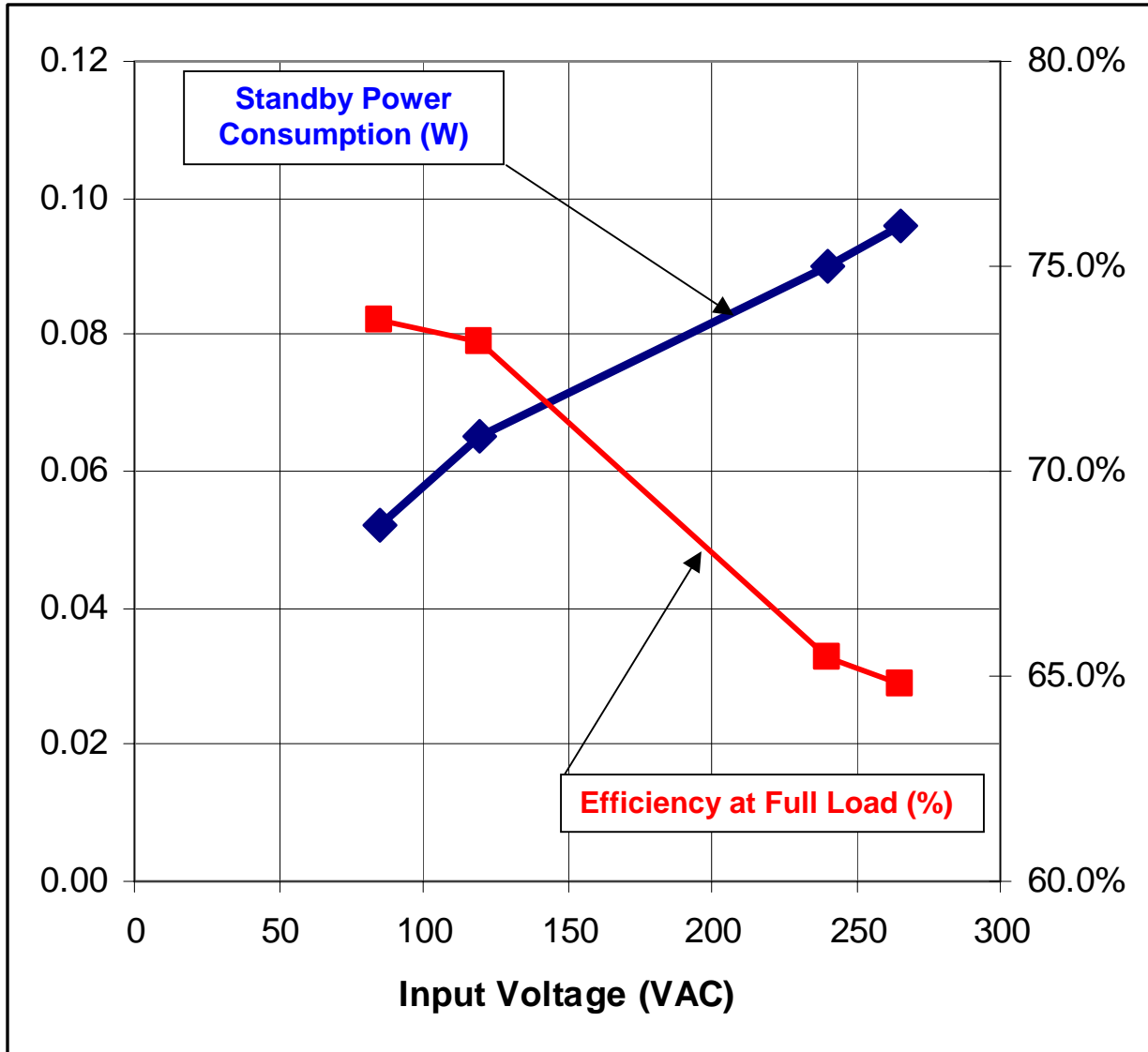

Figure 6- Zero Load Input Power/(Full Load) Efficiency vs. Input Line Voltage, Room Temperature, 60 Hz.



9.3 Regulation

9.3.1 Line and Load Regulation

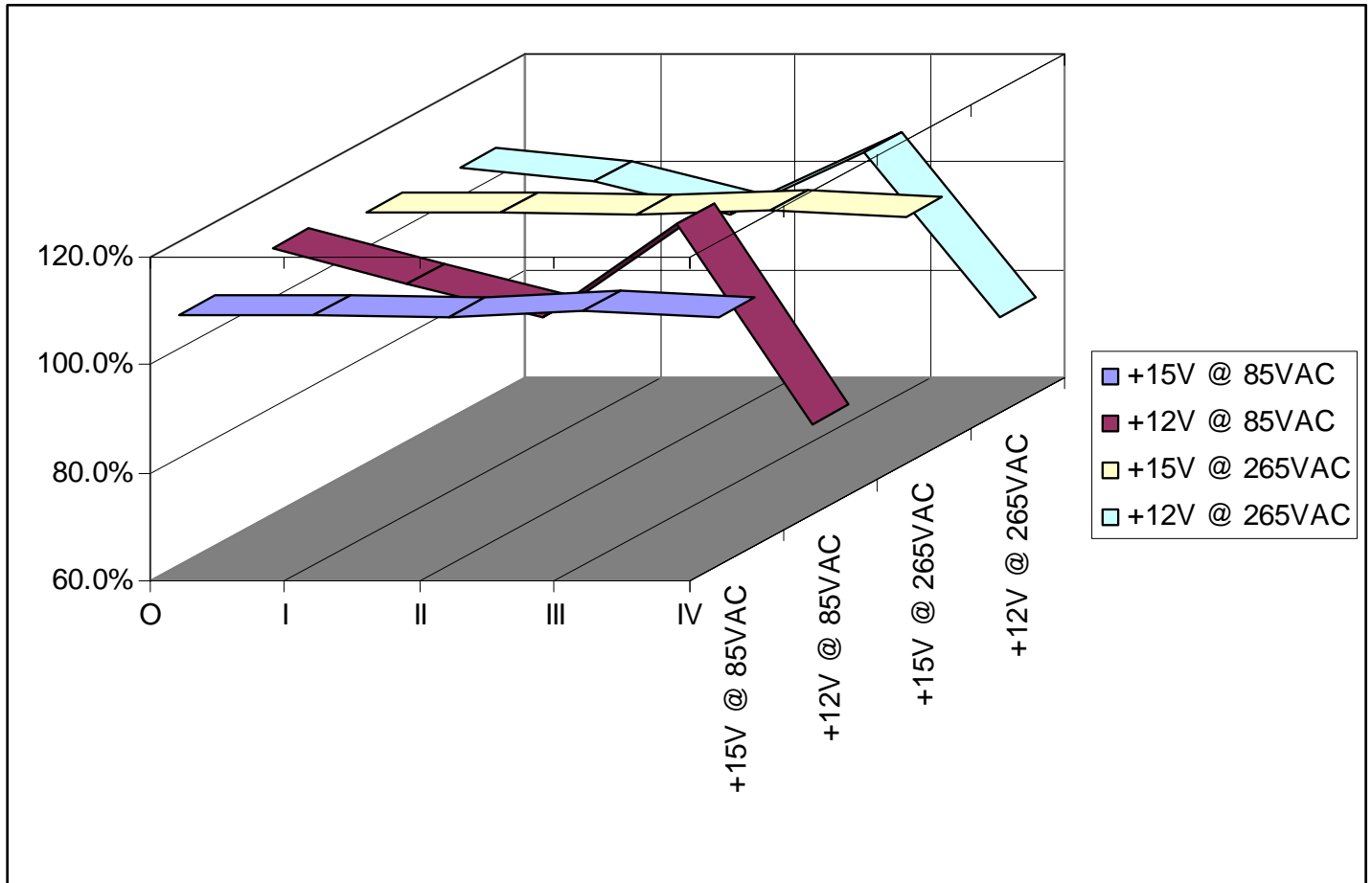

Figure 7 –Load Regulation, Room Temperature.



10 Waveforms

10.1 Drain Voltage and Current, Normal Operation

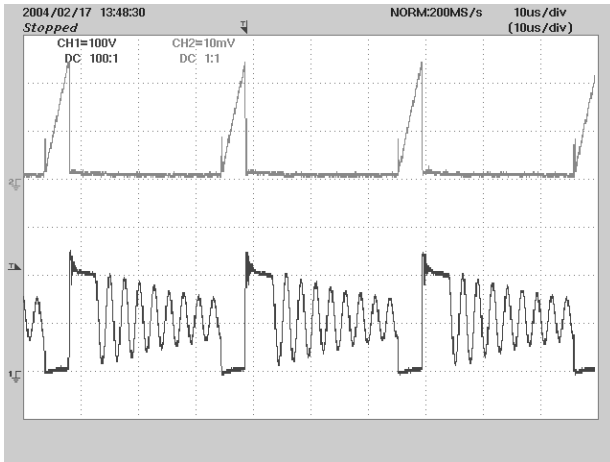

Figure 8 - 85 VAC, Full Load.
 Upper: I_{DRAIN} , 0.1 A / div
 Lower: V_{DRAIN} , 100 V, 10 μ s / div

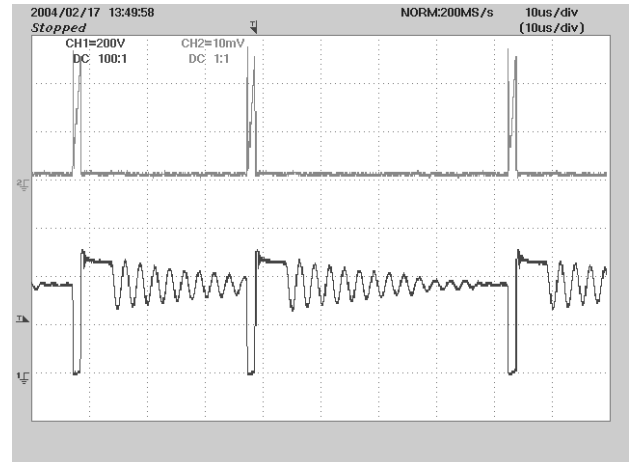

Figure 9 - 265 VAC, Full Load
 Upper: I_{DRAIN} , 0.1 A / div
 Lower: V_{DRAIN} , 200 V / div, 10 μ s / div

10.2 Output Voltage Start-up Profile

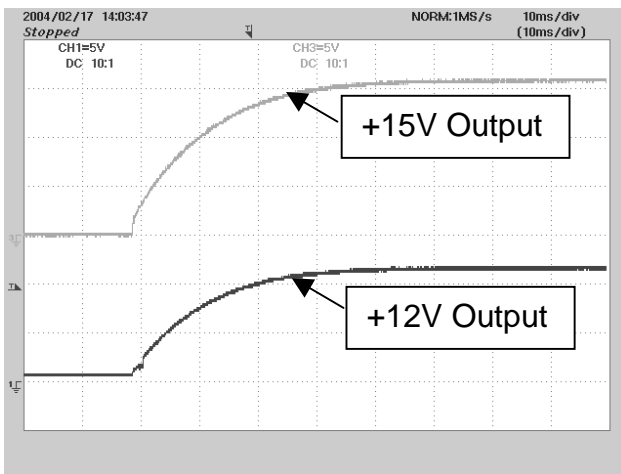

Figure 10 - Start-up Profile, 115VAC
 5 V, 10 ms / div.

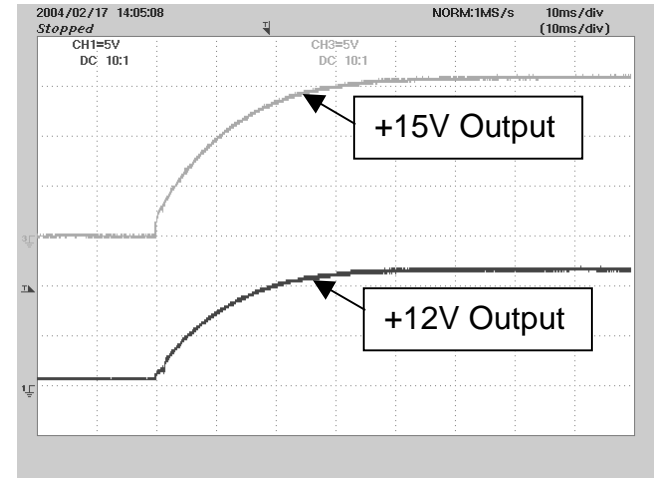

Figure 11 - Start-up Profile, 230 VAC
 5 V, 10 ms / div.



10.3 Drain Voltage and Current Start-up Profile

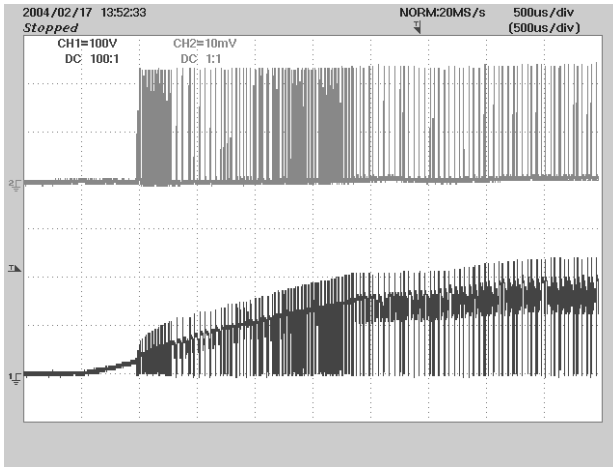

Figure 12 - 85 VAC Input and Maximum Load.
Upper: I_{DRAIN} , 0.1 A / div.
Lower: V_{DRAIN} , 100 V & 500 μ s / div.

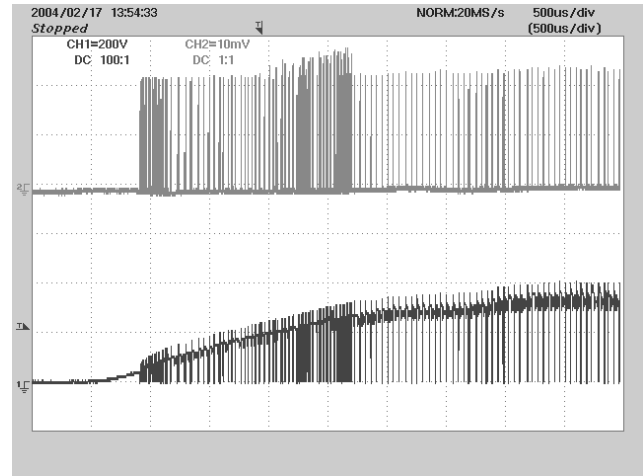

Figure 13 - 265 VAC Input and Maximum Load.
Upper: I_{DRAIN} , 0.1 A / div.
Lower: V_{DRAIN} , 200 V & 500 μ s / div.

10.4 Load Transient Response (50% to 100% Load Step)

In the figures shown below, signal averaging was used to better enable viewing the load transient response. The oscilloscope was triggered using the load current step as a trigger source. Since the output switching and line frequency occur essentially at random with respect to the load transient, contributions to the output ripple from these sources will average out, leaving the contribution only from the load step response. The load on the +12V output was set to maximum (100mA).

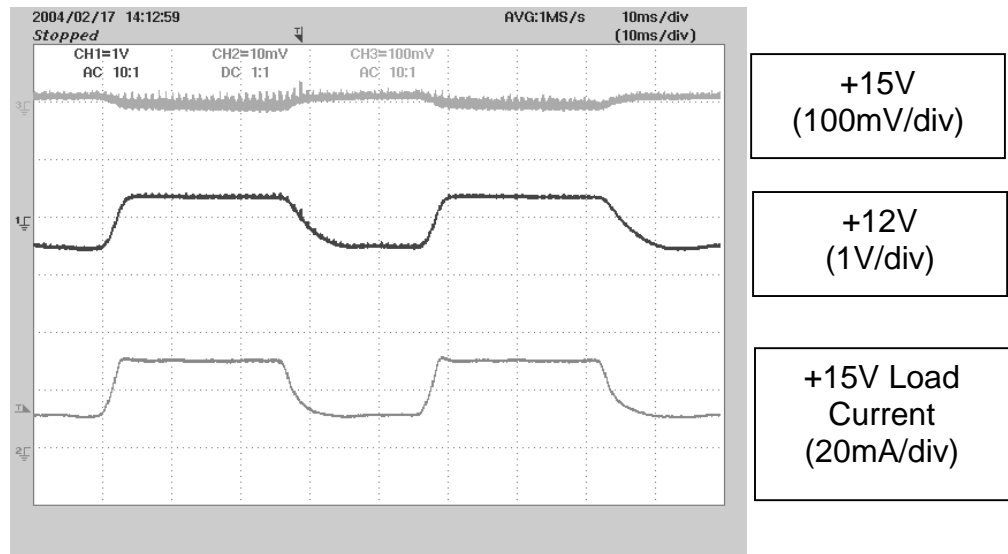

Figure 14 – Transient Response, 115 VAC, 50-100-50% Load Step.
10 ms / div.



10.5 Output Ripple Measurements

10.5.1 Ripple Measurement Technique

For DC output ripple measurements, a modified oscilloscope test probe must be utilized in order to reduce spurious signals due to pickup. Details of the probe modification are provided in Figure 15 and Figure 16.

The 5125BA probe adapter is affixed with two capacitors tied in parallel across the probe tip. The capacitors include one (1) 0.1 $\mu\text{F}/50\text{ V}$ ceramic type and one (1) 1.0 $\mu\text{F}/50\text{ V}$ aluminum electrolytic. **The aluminum electrolytic type capacitor is polarized, so proper polarity across DC outputs must be maintained (see below).**

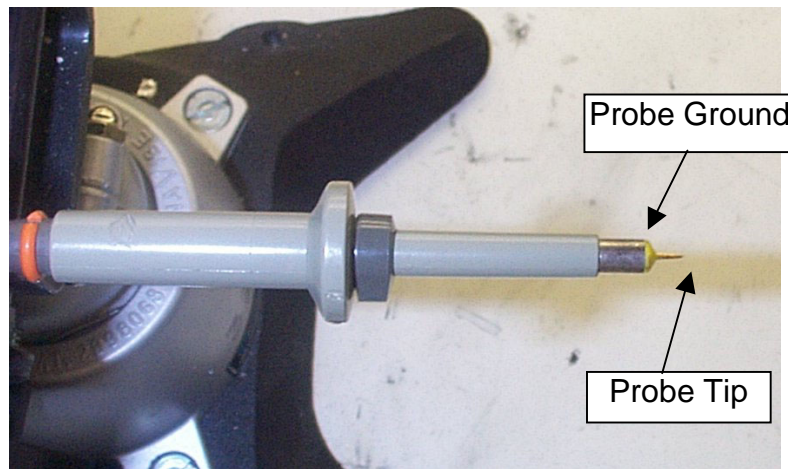

Figure 15 - Oscilloscope Probe Prepared for Ripple Measurement. (End Cap and Ground Lead Removed)

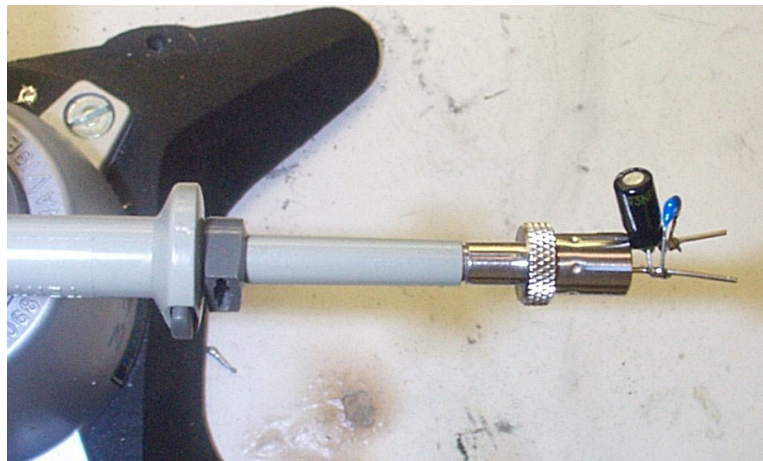

Figure 16 - Oscilloscope Probe with Probe Master 5125BA BNC Adapter. (Modified with wires for probe ground for ripple measurement, and two parallel decoupling capacitors added)

10.5.2 Measurement Results

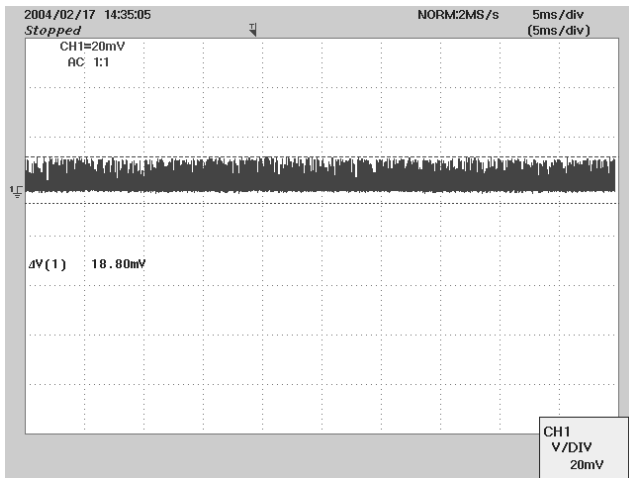

Figure 17 +15V Ripple, 85 VAC, Full Load.
5 ms, 20 mV / div

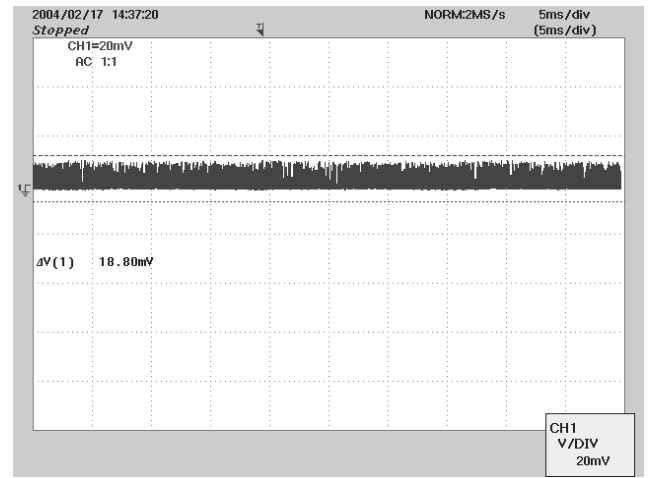

Figure 18 +15 V Ripple, 265 VAC, Full Load.
5 ms, 20 mV / div

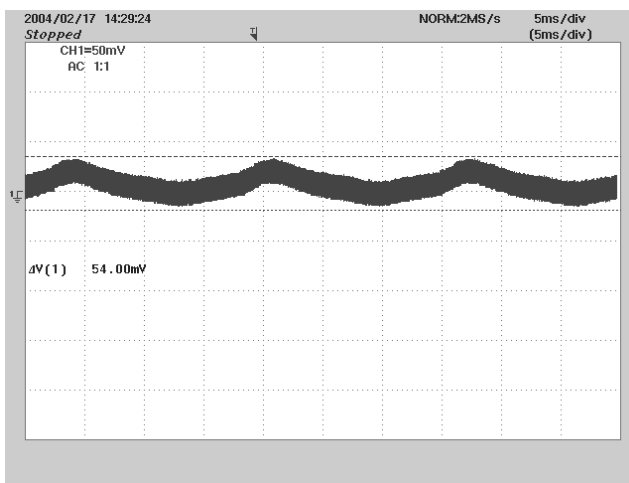

Figure 19 +12V Ripple, 85 VAC, Full Load.
5 ms, 50 mV /div

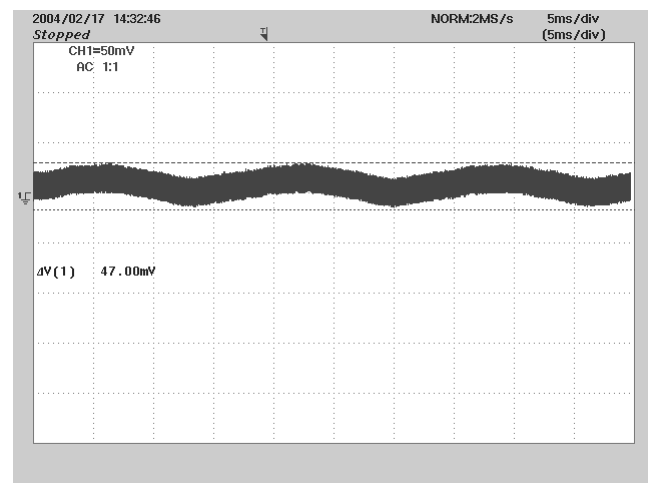

Figure 20 +12V Ripple, 265 VAC, Full Load.
5 ms, 50 mV /div



11 Conducted EMI

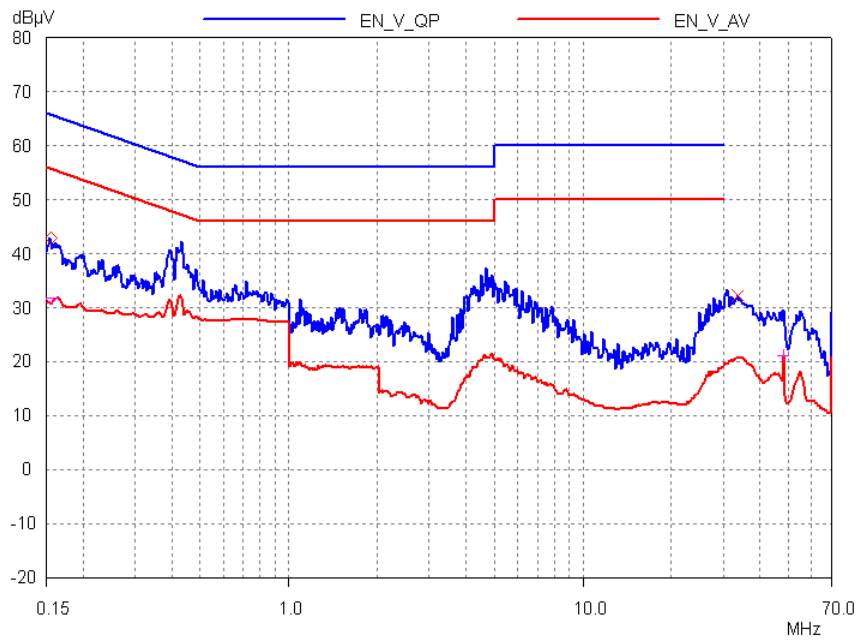

Figure 21 - Conducted EMI, Maximum Steady State Load, 115 VAC, 60 Hz, and EN55022 B Limits.

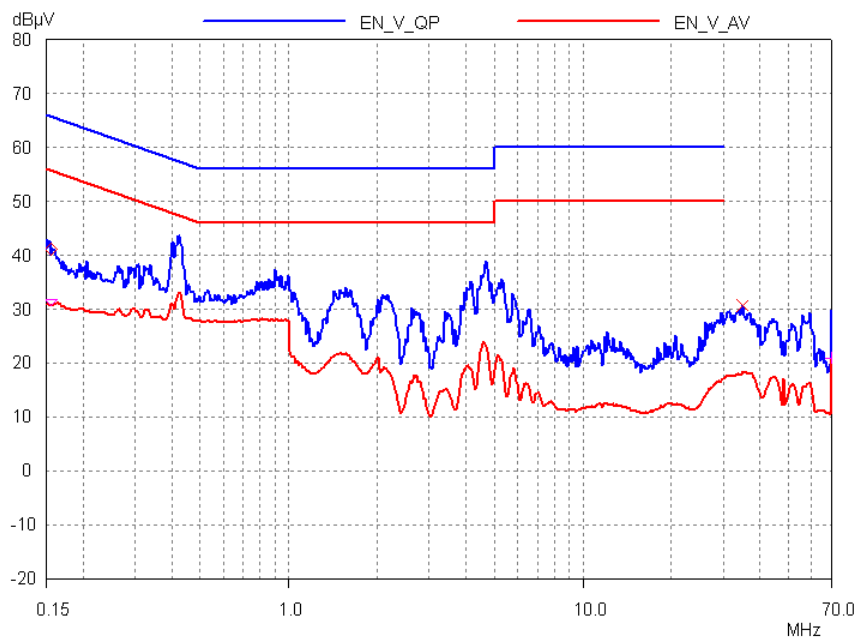

Figure 22 - Conducted EMI, Maximum Steady State Load, 230 VAC, 60 Hz, and EN55022 B Limits.



12 Revision History

Date	Author	Revision	Description & changes	Reviewed
April 20, 2005	RSP	1.0	Initial Release	VC / AM



For the latest updates, visit our Web site: www.powerint.com

Power Integrations may make changes to its products at any time. Power Integrations has no liability arising from your use of any information, device or circuit described herein nor does it convey any license under its patent rights or the rights of others. POWER INTEGRATIONS MAKES NO WARRANTIES HEREIN AND SPECIFICALLY DISCLAIMS ALL WARRANTIES INCLUDING, WITHOUT LIMITATION, THE IMPLIED WARRANTIES OF MERCHANTABILITY, FITNESS FOR A PARTICULAR PURPOSE, AND NON-INFRINGEMENT OF THIRD PARTY RIGHTS.

PATENT INFORMATION

The products and applications illustrated herein (including circuits external to the products and transformer construction) may be covered by one or more U.S. and foreign patents or potentially by pending U.S. and foreign patent applications assigned to Power Integrations. A complete list of Power Integrations' patents may be found at www.powerint.com.

The PI Logo, **TOPSwitch**, **TinySwitch**, **LinkSwitch**, and **EcoSmart** are registered trademarks of Power Integrations. **PI Expert** and **DPA-Switch** are trademarks of Power Integrations.

© Copyright 2004, Power Integrations.

WORLD HEADQUARTERS

Power Integrations
5245 Hellyer Avenue,
San Jose, CA 95138, USA
Main: +1-408-414-9200
Customer Service:
Phone: +1-408-414-9665
Fax: +1-408-414-9765
e-mail:
usasales@powerint.com

AMERICAS

Power Integrations, Inc.
4335 South Lee Street,
Suite G,
Buford, GA 30518, USA
Phone: +1-678-714-6033
Fax: +1-678-714-6012
e-mail:
usasales@powerint.com

CHINA (SHANGHAI)

Power Integrations
International Holdings, Inc.
Rm 807, Pacheer,
Commercial Centre,
555 Nanjing West Road,
Shanghai, 200041, China
Phone: +86-21-6215-5548
Fax: +86-21-6215-2468
e-mail:
chinasales@powerint.com

APPLICATIONS HOTLINE

World Wide +1-408-414-9660

CHINA (SHENZHEN)

Power Integrations
International Holdings, Inc.
Rm# 1705, Bao Hua Bldg.
1016 Hua Qiang Bei Lu,
Shenzhen, Guangdong,
518031, China
Phone: +86-755-8367-5143
Fax: +86-755-8377-9610
e-mail: chinasales@powerint.com

GERMANY

Power Integrations, GmbH
Rueckerstrasse 3,
D-80336, Munich, Germany
Phone: +49-895-527-3910
Fax: +49-895-527-3920
e-mail: eurosales@powerint.com

INDIA (TECHNICAL SUPPORT)

Innovatech
261/A, Ground Floor
7th Main, 17th Cross,
Sadashivanagar
Bangalore, India, 560080
Phone: +91-80-5113-8020
Fax: +91-80-5113-8023
e-mail: indiasales@powerint.com

APPLICATIONS FAX

World Wide +1-408-414-9760

ITALY

Power Integrations s.r.l.
Via Vittorio Veneto 12,
Bresso, Milano,
20091, Italy
Phone: +39-028-928-6001
Fax: +39-028-928-6009
e-mail:
eurosales@powerint.com

JAPAN

Power Integrations, K.K.
Keihin-Tatemono 1st Bldg.
12-20 Shin-Yokohama,
2-Chome,
Kohoku-ku, Yokohama-shi,
Kanagawa 222-0033, Japan
Phone: +81-45-471-1021
Fax: +81-45-471-3717
e-mail:
japansales@powerint.com

KOREA

Power Integrations
International Holdings, Inc.
8th Floor, DongSung Bldg.
17-8 Yoido-dong,
Youngdeungpo-gu,
Seoul, 150-874, Korea
Phone: +82-2-782-2840
Fax: +82-2-782-4427
e-mail:
koreasales@powerint.com

SINGAPORE (ASIA PACIFIC HEADQUARTERS)

Power Integrations, Singapore
51 Newton Road,
#15-08/10 Goldhill Plaza,
Singapore, 308900
Phone: +65-6358-2160
Fax: +65-6358-2015
e-mail:
singaporesales@powerint.com

TAIWAN

Power Integrations
International Holdings, Inc.
17F-3, No. 510,
Chung Hsiao E. Rd., Sec. 5,
Taipei, Taiwan 110, R.O.C.
Phone: +886-2-2727-1221
Fax: +886-2-2727-1223
e-mail:
taiwansales@powerint.com

UK (EUROPE & AFRICA HEADQUARTERS)

1st Floor, St. James's House
East Street
Farnham, Surrey GU9 7TJ
United Kingdom
Phone: +44-1252-730-140
Fax: +44-1252-727-689
e-mail: eurosales@powerint.com

