

FEATURES

- 30 - 600 MHz
- SP2T & SP6T In a 24 Pin DIP
- CMOS Control
- Low Current Consumption



MODEL NO.
CSWX1923

PIN Diode SP2T & SP6T

HDI

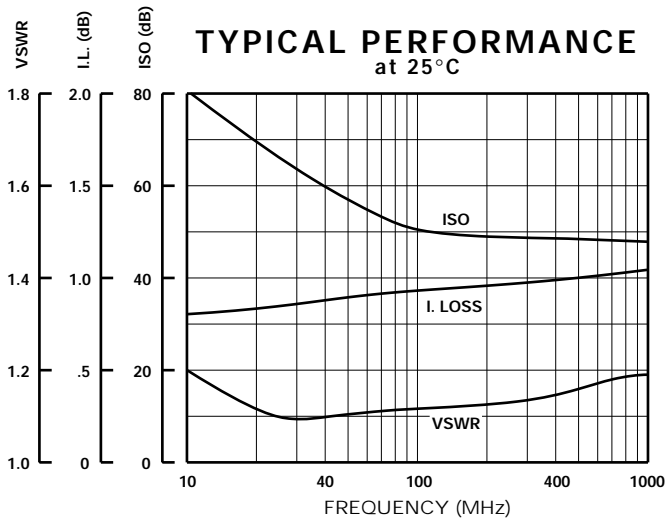
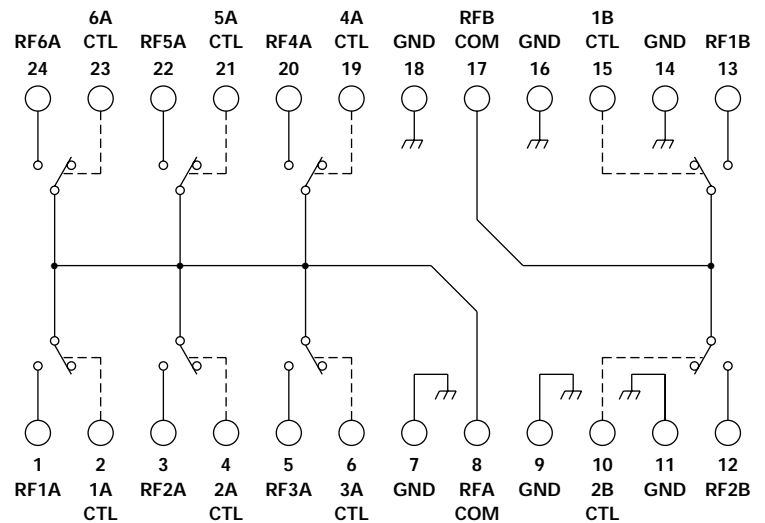
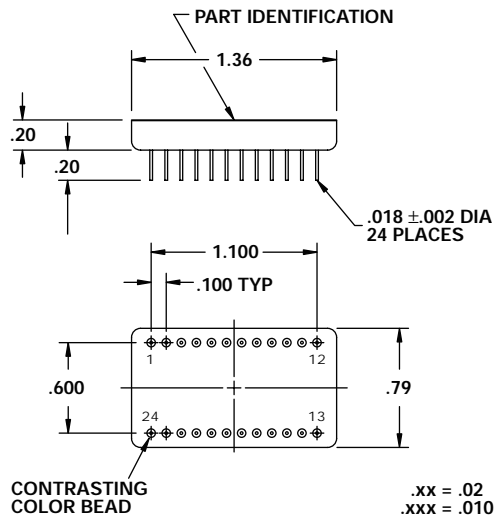

GUARANTEED PERFORMANCE

Parameter	Min	Typ	Max	Units	Conditions
Operating Frequency	30		600	MHz	
Control Type		CMOS			8 Line - One to Each Switch; Compatible With MC88C29 Driver Logic: +12V = Thru +0V = Isolation
Control Current					
	<i>High</i>	4	10	mA	V _{IH} = +12V
	<i>Low</i>	0	0	mA	V _{IL} = +0V
Insertion Loss		1.1	1.7	dB	
Isolation	37	47		dB	
VSWR	<i>Thru</i>	1.2/1	1.6/1		
Impedance		50		OHMS	
Switching Speed		62	100	µSec	50% TTL to 10% / 90% RF
Transition (Rise/Fall) Time		34		µSec	10% / 90% or 90% / 10% RF
Switching (Video) Transients		140		mV	Peak Value
Intercept Points					
	<i>2nd</i>	+73		dBm	70 MHz / 50 MHz
	<i>3rd</i>	+52		dBm	35 MHz / 50 MHz
RF Power					
	<i>Operate</i>	+21	+10	dBm	0.1 dB Compression
	<i>No Damage</i>		+20	dBm	
Operating Temperature	-55	+25	+85	°C	TA