

4 Channel EMI Filter Network

Features

- 4 EMI filter lines per device
- Filters attenuate to -30dB at 3GHz
- CSP package minimizes cross-talk
- 9-bump $2.485\text{mm} \times 0.985\text{mm}$ Chip Scale Package (CSP), 0.5mm pitch
- 0.30mm Eutectic solder bumps
- Ultra small footprint suitable for portable devices
- Lead-free version available

Applications

- EMI filtering for RF sections of wireless devices
- Cellular phones
- Cordless phones
- Internet appliances
- PDAs
- Laptop computers

Product Description

The CSPRC032A is a 4-channel low pass EMI filter (R-C-R configuration) in a Chip Scale Package (CSP). Many portable applications require the attenuation of signals in the $800\text{-}3000\text{ MHz}$ band. California Micro Devices' unique thin film technology provides a minimum of -25dB of attenuation over this frequency band.

The bump size and pitch of these filters are selected such that the device can be placed directly on an FR4 printed circuit board using conventional assembly techniques. The pin-out for the device features a signal 'flow through' design, allowing optimal signal routing. The solder bump contacts are a $63/37\text{ Sn/Pb}$ alloy (Sn/Ag/Cu for lead-free finish) and are 0.30 mm in diameter.

The CSPRC032A is available in a space-saving, low-profile Chip Scale Package with optional lead-free finishing.

Electrical Schematic

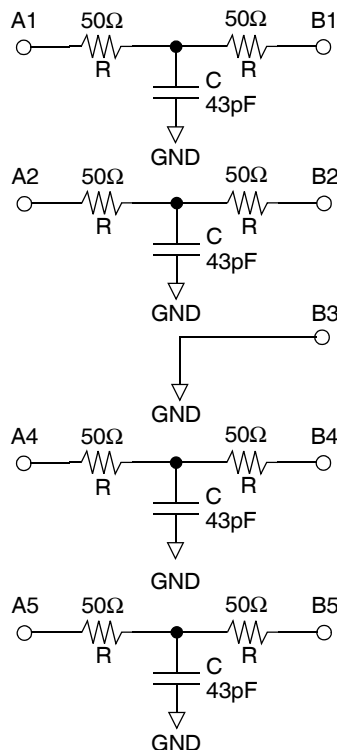

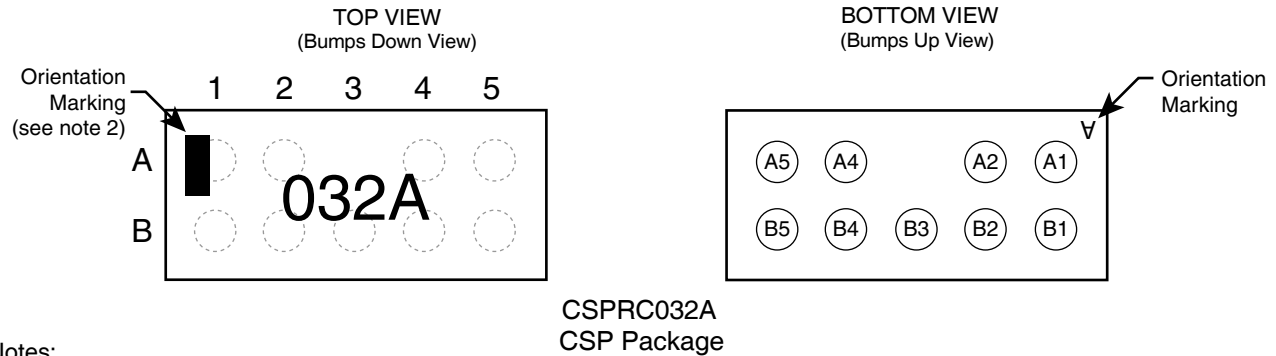
PACKAGE / PINOUT DIAGRAMS

Notes:

- 1) These drawings are not to scale.
- 2) Lead-free devices are specified by using a "+" character for the top side orientation mark.

Ordering Information

PART NUMBERING INFORMATION

Bumps	Package	Standard Finish		Lead-free Finish ²	
		Ordering Part Number ¹	Part Marking	Ordering Part Number ¹	Part Marking
9	CSP	CSPRC032A	032A	CSPRC032AG	032A

Note 1: Parts are shipped in Tape & Reel form unless otherwise specified.

Note 2: Lead-free devices are specified by using a "+" character for the top side orientation mark.

Specifications

ABSOLUTE MAXIMUM RATINGS

PARAMETER	RATING	UNITS
Storage Temperature Range	-55 to +150	°C
Power Rating per Resistor	25	mW

STANDARD OPERATING CONDITIONS

PARAMETER	RATING	UNITS
Operating Temperature Range	-40 to +85	°C

ELECTRICAL OPERATING CHARACTERISTICS(NOTE 1)

SYMBOL	PARAMETER	CONDITIONS	MIN	TYP	MAX	UNITS
I_{LEAK}	Leakage Current, An or Bn to GND	$V_{IN}=6.0V$			1	μA
R	Resistance		45	50	55	Ω
C	Capacitance		34	43	52	pF
TOL_R	Resistor Absolute Tolerance	$R = 50\Omega$			± 10	%
TOL_C	Capacitor Absolute Tolerance	$C=43pF$			± 20	%
TCR	Temperature Coefficient of Resistance	Note 2			± 150	ppm/ $^{\circ}C$
TCC	Temperature Coefficient of Capacitance	Note 2			± 500	ppm/ $^{\circ}C$
F_C	Filter Cutoff Frequency $Z_{SOURCE}=0\Omega$ $Z_{LOAD}=\infty$ $Z_{SOURCE}=50\Omega$ $Z_{LOAD}=50\Omega$	$R=50\Omega$ $C=43pF$;		74 82		MHz MHz

Note 1: Electrical Operating Characteristics are guaranteed over the Operating Temperature Range unless otherwise specified.

Note 2: Parameters guaranteed by design or characterization.

Filter Performance

CSPRC032 Filter Typical Measured Frequency Response (S21) Measurement

The measurement is done with 50 Ω -source and 50 Ω -load impedance using a HP8753C Network Analyzer with a HP85047A S-parameter Test Set.

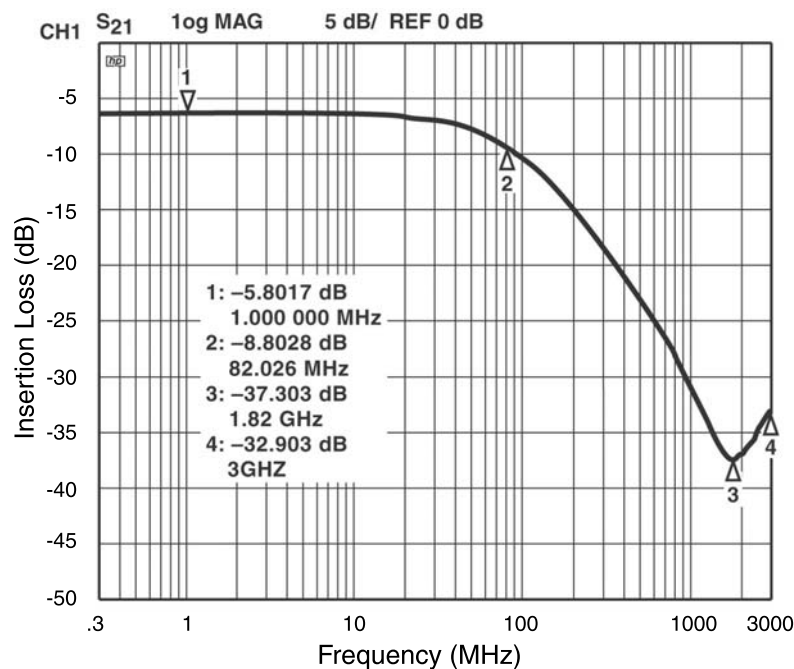

Application Information

Refer to Application Note AP-217, "The Chip Scale Package", for a detailed description of Chip Scale Packages offered by California Micro Devices.

PRINTED CIRCUIT BOARD RECOMMENDATIONS

PARAMETER	VALUE
Pad Size on PCB	0.275mm
Pad Shape	Round
Pad Definition	Non-Solder Mask defined pads
Solder Mask Opening	0.325mm Round
Solder Stencil Thickness	0.125 - 0.150mm
Solder Stencil Aperture Opening (laser cut, 5% tapered walls)	0.330mm Round
Solder Flux Ratio	50/50 by volume
Solder Paste Type	No Clean
Pad Protective Finish	OSP (Entek Cu Plus 106A)
Tolerance — Edge To Corner Ball	$\pm 50\mu\text{m}$
Solder Ball Side Coplanarity	$\pm 20\mu\text{m}$
Maximum Dwell Time Above Liquidous	60 seconds
Maximum Soldering Temperature for Eutectic Devices using Eutectic Solder Paste	240°C
Maximum Soldering Temperature for Lead-free Devices using Lead-free Solder Paste	260°C

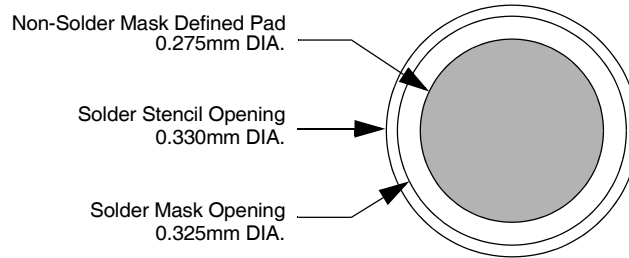

Figure 1. Recommended Non-Solder Mask Defined Pad Illustration

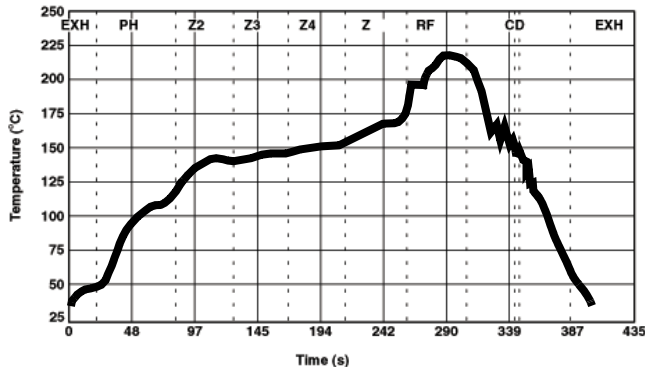

Figure 2. Eutectic (SnPb) Solder Ball Reflow Profile

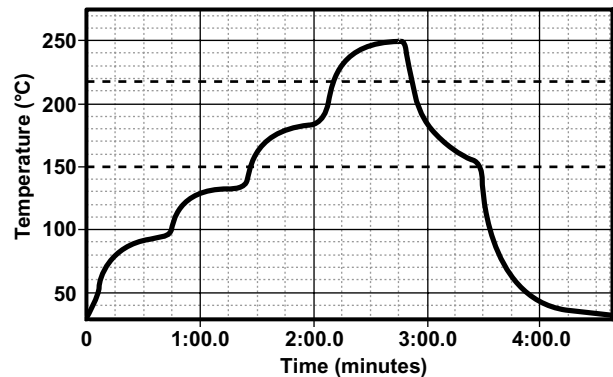

Figure 3. Lead-free (SnAgCu) Solder Ball Reflow Profile

Mechanical Details

CSP Mechanical Specifications

The CSPRC032A is offered in a custom Chip Scale Package (CSP). Dimensions are presented below. For complete information on CMD's Chip Scale Packaging, see the California Micro Devices CSP Package Information document.

PACKAGE DIMENSIONS						
Package	Custom CSP					
Bumps	9					
Dim	Millimeters			Inches		
	Min	Nom	Max	Min	Nom	Max
A1	0.940	0.985	1.030	0.0370	0.0388	0.0406
A2	2.440	2.485	2.530	0.0961	0.0978	0.0996
B1	0.495	0.500	0.505	0.0195	0.0197	0.0199
B2	0.495	0.500	0.505	0.0195	0.0197	0.0199
C1	0.1925	0.2425	0.2925	0.0076	0.0095	0.0115
C2	0.1925	0.2425	0.2925	0.0076	0.0095	0.0115
D1	0.561	0.605	0.649	0.0221	0.0238	0.0256
D2	0.355	0.380	0.405	0.0140	0.0150	0.0160
# per tape and reel	3500 pieces					
Controlling dimension: millimeters						

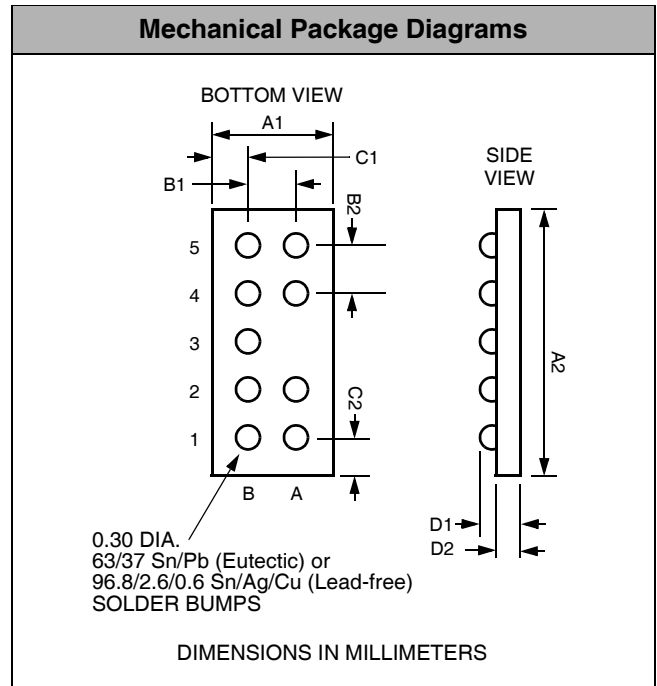

Package Dimensions for CSPRC032A 9-bump Chip Scale Package

CSP Tape and Reel Specifications

PART NUMBER	PKG. SIZE (mm)	POCKET SIZE (mm) $B_0 \times A_0 \times K_0$	TAPE WIDTH W	REEL DIA.	QTY PER REEL	P_0	P_1
CSPRC032A	2.485 X 0.985 X 0.605	2.62 X 1.12 X 0.762	8mm	178mm (7")	3500	4mm	4mm

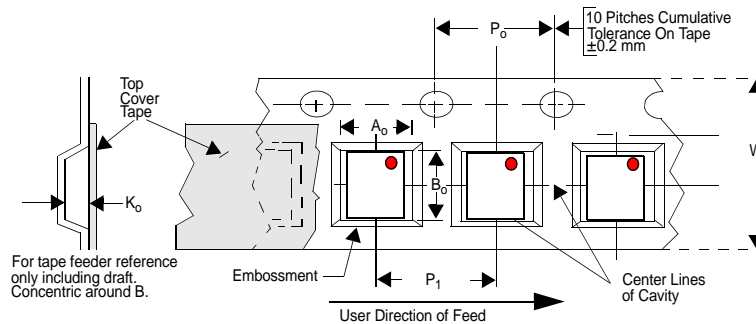

Figure 4. Tape and Reel Mechanical Data