

Low $V_{CE(sat)}$ NPN Planar Transistor

BTD5765B3

Features

- High current capability
- Low collector-to-emitter saturation voltage
- High allowable power dissipation

Applications

- Relay drivers, lamp drivers, motor drivers, strobes

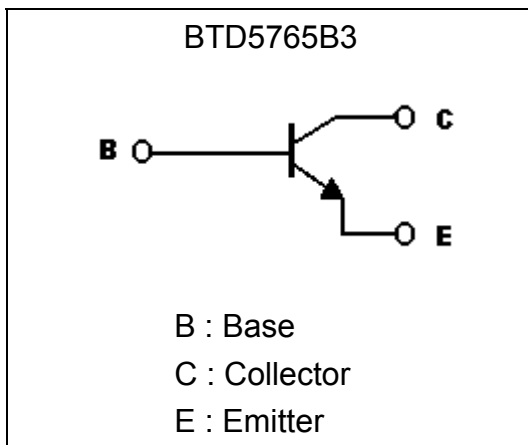
Symbol

Absolute Maximum Ratings (Ta=25°C)

Parameter	Symbol	Limits	Unit
Collector-Base Voltage	V_{CBO}	15	V
Collector-Emitter Voltage	V_{CEO}	10	V
Emitter-Base Voltage	V_{EBO}	7	V
Collector Current (DC)	I_C	5	A
Collector Current (Pulse)	I_{CP}	9	A
Collector Power Dissipation (Note)	P_D	550	mW
Junction Temperature	T_j	150	°C
Storage Temperature	T_{stg}	-55~+150	°C

Note : when a device is mounted on a glass epoxy board, measuring 35mm×30mm×1mm.

**Characteristics (Ta=25°C)**

Symbol	Min.	Typ.	Max.	Unit	Test Conditions
BV_{CB0}	15	-	-	V	$I_C=100\mu A, I_E=0$
BV_{CEO}	10	-	-	V	$I_C=1mA, I_B=0$
BV_{EBO}	7	-	-	V	$I_E=10\mu A, I_C=0$
I_{CBO}	-	-	100	nA	$V_{CB}=15V, I_E=0$
I_{EBO}	-	-	100	nA	$V_{EB}=5V, I_C=0$
$*V_{CE(sat)1}$	-	-	180	mV	$I_C=1.5A, I_B=30mA$
$*V_{CE(sat)2}$	-	230	350	mV	$I_C=3A, I_B=60mA$
$*V_{BE(sat)}$	-	-	0.95	1.2V	$I_C=1.5A, I_B=30mA$
$*h_{FE1}$	450	-	-	-	$V_{CE}=2V, I_C=500mA$
$*h_{FE2}$	400	-	800	-	$V_{CE}=2V, I_C=2A$
$*h_{FE3}$	200	-	-	-	$V_{CE}=2V, I_C=5A$
f_T	-	170	-	MHz	$V_{CE}=6V, I_C=50mA, f=100MHz$
Cob	-	25	-	pF	$V_{CB}=10V, f=1MHz$

*Pulse Test: Pulse Width $\leq 380\mu s$, Duty Cycle $\leq 2\%$

Characteristic Curves

Output Characteristics

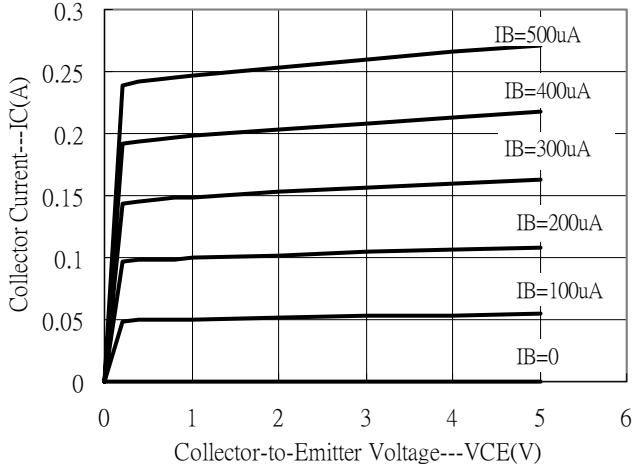

Output Characteristics

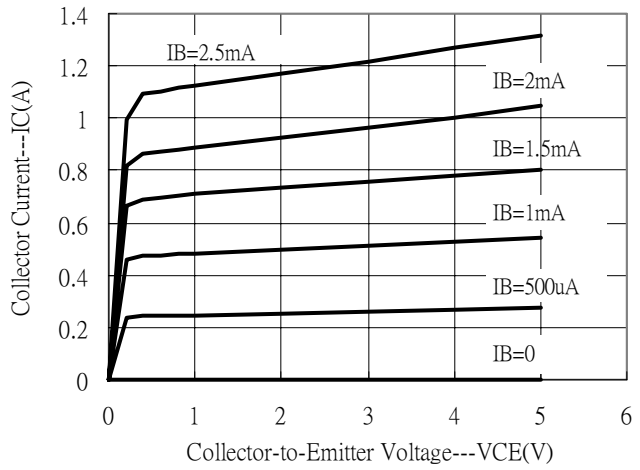

Output Characteristics

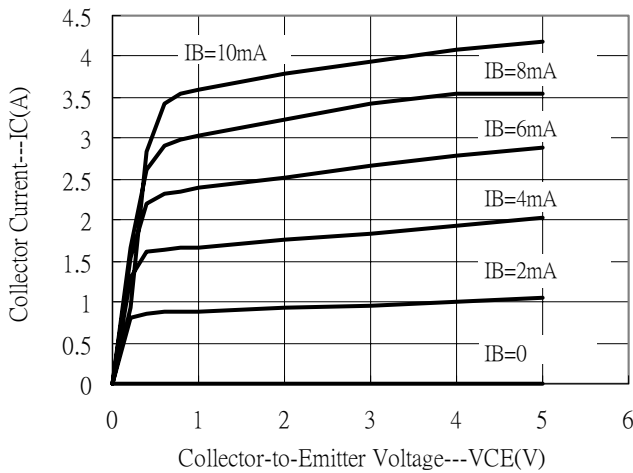

Output Characteristics

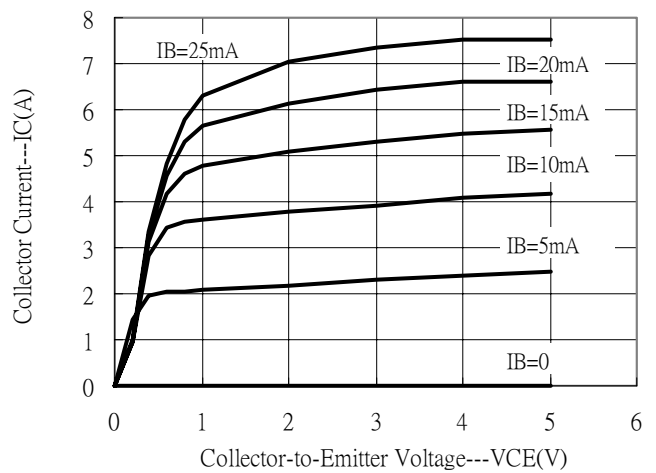

Current Gain vs Collector Current

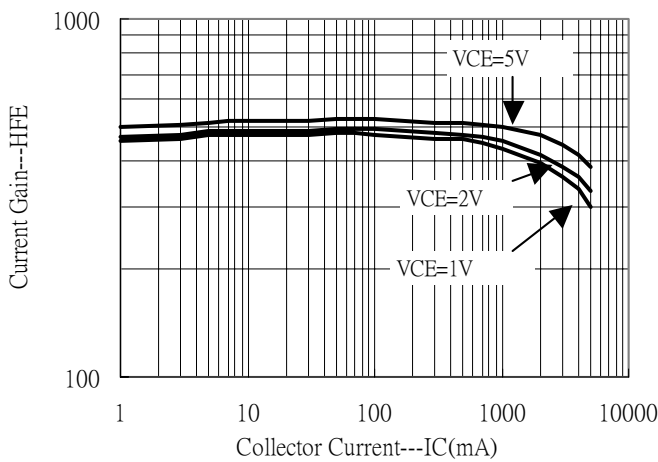

Saturation Voltage vs Collector Current

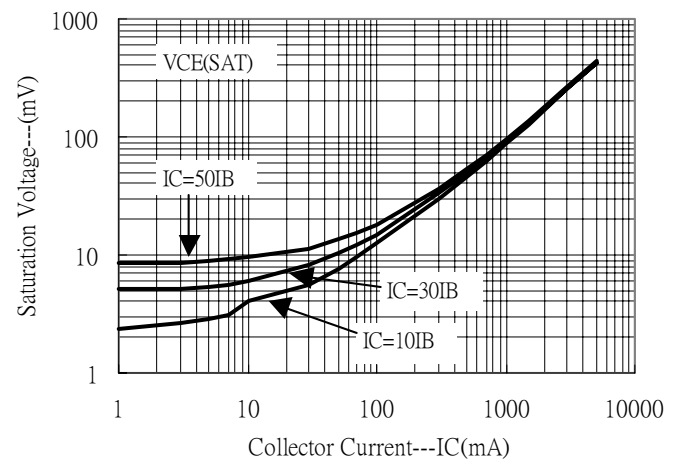



Saturation Voltage vs Collector Current

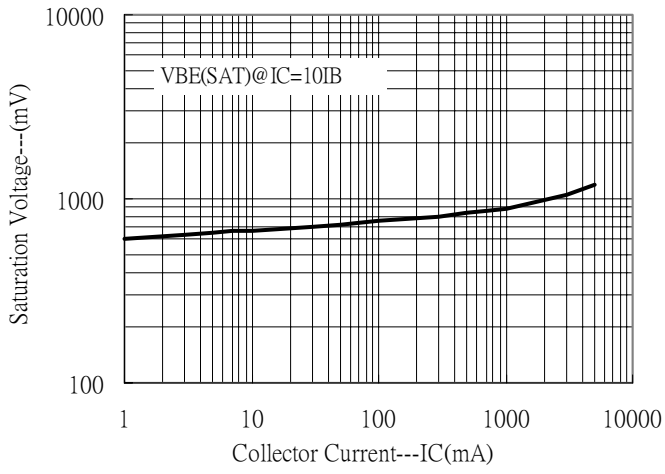

Power Derating Curve

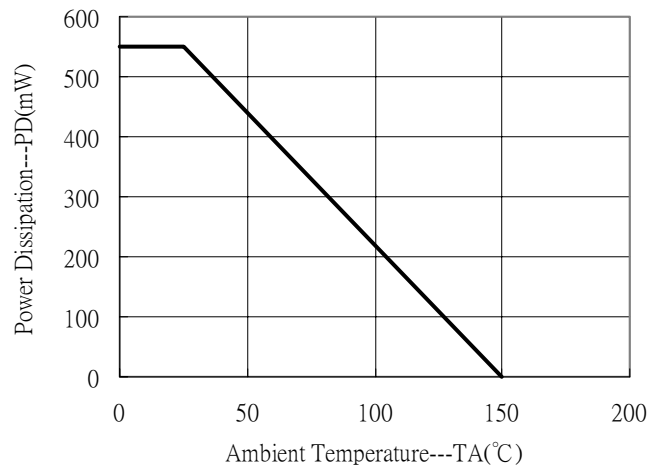

TO-92SP Dimension

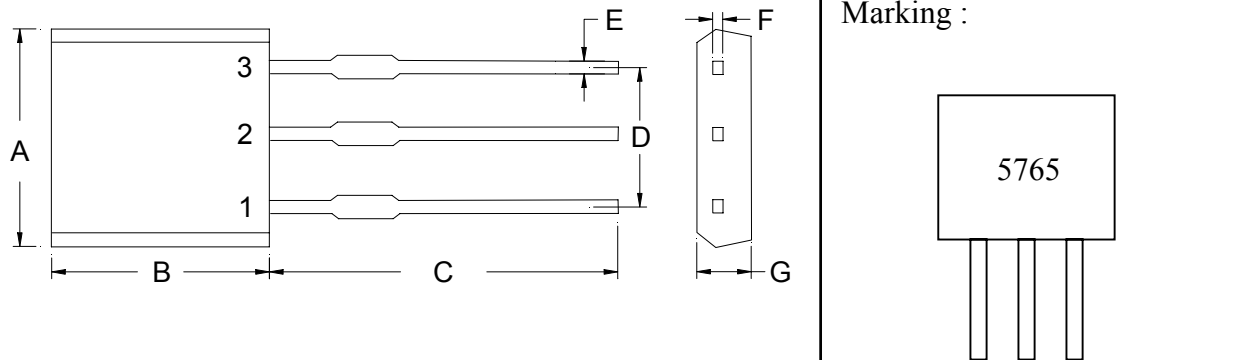

3-Lead TO-92SP Plastic Package
 CYStek Package Code: B3

Style: Pin 1. Emitter 2. Collector 3. Base

*: Typical

DIM	Inches		Millimeters		DIM	Inches		Millimeters	
	Min.	Max.	Min.	Max.		Min.	Max.	Min.	Max.
A	0.1450	0.1650	3.70	4.20	E	0.0160	0.0240	0.41	0.61
B	0.1063	0.1300	2.70	3.30	F	-	*0.0150	-	*0.38
C	0.5000	-	12.7	-	G	0.0800	0.1050	2.03	2.67
D	-	*0.1000	-	*2.54					

Notes: 1. Controlling dimension: millimeters.
 2. Maximum lead thickness includes lead finish thickness, and minimum lead thickness is the minimum thickness of base material.
 3. If there is any question with packing specification or packing method, please contact your local CYStek sales office.

Material:

- Lead: 42 Alloy; solder plating
- Mold Compound: Epoxy resin family, flammability solid burning class: UL94V-0

Important Notice:

- All rights are reserved. Reproduction in whole or in part is prohibited without the prior written approval of CYStek.
- CYStek reserves the right to make changes to its products without notice.
- CYStek **semiconductor products are not warranted to be suitable for use in Life-Support Applications, or systems.**
- CYStek assumes no liability for any consequence of customer product design, infringement of patents, or application assistance.