

BLB102SURC/E28V

HYPER RED

Features

- BUILT-IN CURRENT LIMITING RESISTOR FOR DIRECT APPLICATION OF DIFFERENT ACROSS CURRENT.
- LONG LIFE.
- LOW CURRENT, POWER SAVINGS.
- LOW MAINTENANCE.
- SOLID STATE, HIGH VIBRATION RESISTANT.
- 28V INTERNAL RESISTOR.

Description

The Hyper Red source color devices are made with DH InGaAlP on GaAs substrate Light Emitting Diode.

Package Dimensions

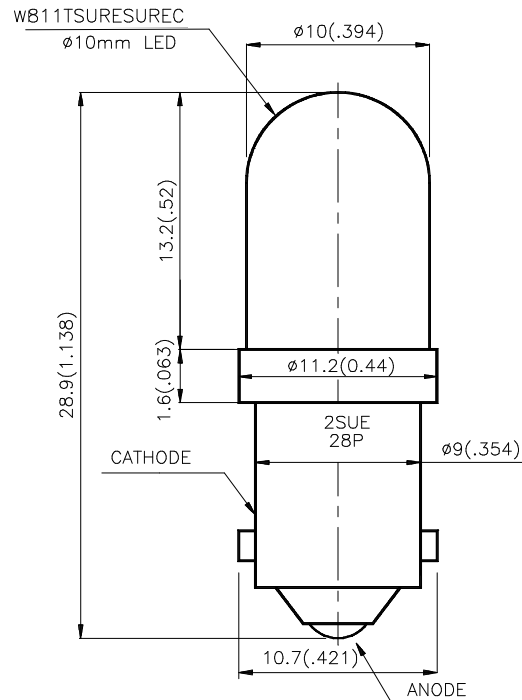

Notes:

1. All dimensions are in millimeters (inches).
2. Tolerance is $\pm 0.25(0.01")$ unless otherwise noted.
3. Specifications are subject to change without notice.

Selection Guide

Part No.	Dice	Lens Type	Iv (mcd) V=28V		Viewing Angle
			Min.	Typ.	2θ1/2
BLB102SURC/E28V	HYPER RED (InGaAlP)	WATER CLEAR	480	1300	40°

Note:

1. θ1/2 is the angle from optical centerline where the luminous intensity is 1/2 the optical centerline value.

Electrical / Optical Characteristics at T_A=25°C

Symbol	Parameter	Device	Typ.	Max.	Units	Test Conditions
λ _{peak}	Peak Wavelength	Hyper Red	640		nm	V _F =28V
λ _D	Dominate Wavelength	Hyper Red	630		nm	V _F =28V
Δλ _{1/2}	Spectral Line Half-width	Hyper Red	25		nm	V _F =28V
I _F	Forward Current	Hyper Red	10.5		mA	V _F =28V
I _R	Reverse Current	Hyper Red		10	μA	V _R =5V

Absolute Maximum Ratings at T_A=25°C

Parameter	Hyper Red	Units
Power dissipation	400	mW
DC Forward Voltage	30	V
Reverse Voltage	5	V
Operating Temperature	-40 To +70	°C
Storage Temperature	-40 To +85	°C

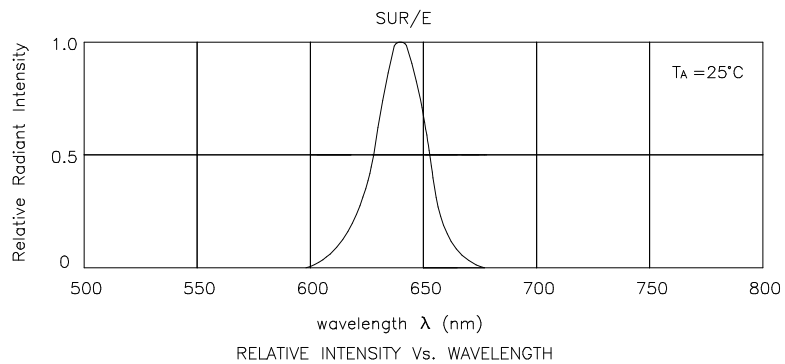

Hyper Red

BLB102SURC/E28V

