

DESCRIPTION The BA1F4N is designed for use in medium speed switching circuit.

FEATURE • Bias resistors built-in type NPN transistor equivalent circuit.

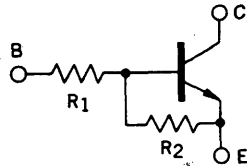

$R_1 = 22 \text{ k}\Omega$

$R_2 = 47 \text{ k}\Omega$

ABSOLUTE MAXIMUM RATINGS

Maximum Temperatures

Storage Temperature -55 to $+150$ °C

Junction Temperature 150 °C Maximum

Maximum Power Dissipation ($T_a = 25$ °C)

Total Power Dissipation 250 mW

Maximum Voltages and Currents ($T_a = 25$ °C)

V_{CBO} Collector to Base Voltage 60 V

V_{CEO} Collector to Emitter Voltage 50 V

V_{EBO} Emitter to Base Voltage 5.0 V

$I_{C(DC)}$ Collector Current (DC) 100 mA

$I_{C(pulse)}$ Collector Current (pulse) 200 mA

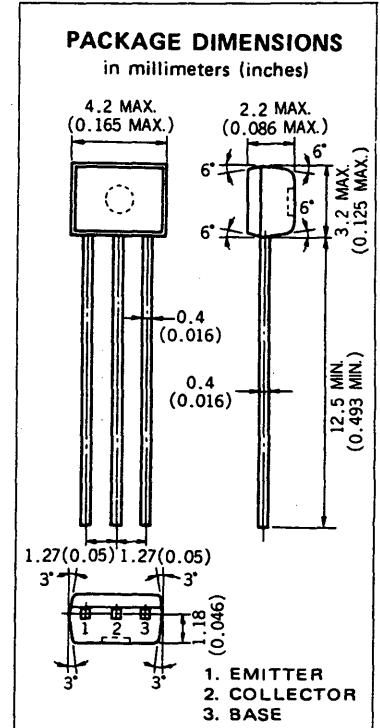

ELECTRICAL CHARACTERISTICS ($T_a = 25$ °C)

SYMBOL	CHARACTERISTIC	MIN.	TYP.	MAX.	UNIT	TEST CONDITIONS
R_1	Input Resistance	15.4	22.0	28.6	$\text{k}\Omega$	
R_2	Input Resistance	32.9	47.0	61.1	$\text{k}\Omega$	
V_{IL}	Low Level Input Voltage		0.8	0.6	V	$V_{CE} = 5.0 \text{ V}, I_C = 100 \mu\text{A}$
V_{IH}	Hi Level Input Voltage	3.0	1.3		V	$V_{CE} = 0.2 \text{ V}, I_C = 5.0 \text{ mA}$
t_{on}	Turn On Time		0.2	0.3	μs	$V_{CC} = 5.0 \text{ V}, R_L = 1.0 \text{ k}\Omega,$ $V_{in} = 5.0 \text{ V},$ $PW = 2 \mu\text{s}, \text{Duty Cycle} \leq 2\%$
t_{stg}	Storage Time		3.0	5.0	μs	
t_{off}	Turn Off Time		3.5	6.0	μs	
h_{FE1}	DC Current Gain	85	200	340	—	$V_{CE} = 5.0 \text{ V}, I_C = 5.0 \text{ mA}$
h_{FE2}	DC Current Gain	95	230		—	$V_{CE} = 5.0 \text{ V}, I_C = 50 \text{ mA}$
$V_{CE(sat)}$	Collector Saturation Voltage		0.04	0.2	V	$I_C = 5.0 \text{ mA}, I_B = 0.25 \text{ mA}$
I_{CBO}	Collector Cutoff Current			0.1	μA	$V_{CB} = 50 \text{ V}, I_E = 0$

TYPICAL CHARACTERISTICS ($T_a = 25^\circ\text{C}$)

