

1.24V Adjustable Shunt Regulator

B431L

Description

The B431L is a three terminal adjustable shunt regulator with thermal stability of 50ppm/°C. The output voltage can be adjusted to any value from 1.24V (V_{REF}) to 16V with two external resistors. These devices have a typical output impedance of 0.05Ω. Active output circuitry provides a very sharp turn-on characteristics and making the device excellent replacement for zener diodes in many applications. The B431L is an ideal voltage reference in an isolated feedback circuit for 3.0V switch mode power supplies

The B431L shunt regulator is available with three voltage tolerances (0.5%, 1.0% and 2.0%) and three package options (SOT-23-3, TO-92, 8SOIC). This allows the designer the opportunity to select the optimum combination of cost and performance for their application.

Features

- **Low voltage operation (down to 1.24V)**
- **Wide operating current.....80μA to 100mA**
- **Trimmed bandgap design..... ± 0.5%**
- **Low Dynamic Output Impedance.....0.05Ω**
- **Wide temperature range..... -40°C to +85°C**
- **Available inSOT-23-3, TO-92 , 8SOIC**
- **Pin-to-Pin ReplacementSC431L**

Applications

- **Switching Power Supplies**
- **Adjustable Power Supplies**
- **Linear Regulators**
- **Battery Powered Equipment**
- **Monitors, TV, VCR**
- **Instrumentation**

Pin Connection

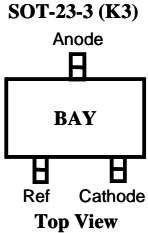
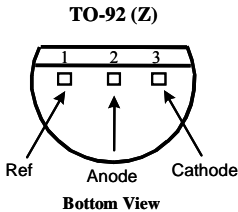

Ordering Information

Package	Tolerance		
	0.5%	1%	2%
TO-92	B431LAZ	B431LBZ	B431LCZ
SO-8	B431LAM	B431LBM	B431LCM
SOT-23	B431LAK3	B431LBK3	B431LCK3

Absolute Maximum Rating

Parameter	Symbol	Maximum	Units
Cathode Voltage	V_Z	20	V
Continuous Cathode Current	I_Z	100	mA
Reference Input Current Range		3	mA
Power Dissipation at $T_A = 25^\circ\text{C}$ SOT-23-3 S0-8 TO-92	P_D	0.37 0.75 0.95	W
Thermal Resistance SOT-23-3 S0-8 TO-92	θ_{JA}	336 175 132	$^\circ\text{C}/\text{W}$
Operating Junction Temperature Range	T_J	-40 to +150	$^\circ\text{C}$
Storage Temperature Range	T_{STG}	-65 to +150	$^\circ\text{C}$
Lead Temperature (Soldering) 10 seconds	T_{LEAD}	300	$^\circ\text{C}$
ESD Rating (Human Body Model)	T_{ESD}	2	kV

Recommended Operating Conditions

	Min	Max	Symbol
Cathode Voltage, V_Z	V_{REF}	16	V
Cathode Current, I_Z	80 μA	100	mA

Electrical Characteristics

Unless specified: $T_A = 25^\circ\text{C}$. Values in bold apply over full operating ambient temperature.

Parameter	Symbol	Condition	B431LA 0.5%			Units
			Min	Typ	Max	
Reference Voltage	V_{REF}	$V_Z = V_{REF1}$, $I_Z = 10\text{mA}^{(1)}$	1.234 1.222	1.240	1.246 1.258	V
V_{REF} Temp Deviation	V_{DEV}	$V_Z = V_{REF1}$, $I_Z = 10\text{mA}^{(1)}$ $I_A = \text{full range}$		10	25	mV
Ratio of Change in V_{REF} To Change in V_Z	$\frac{\Delta V_{REF}}{\Delta V_Z}$	$I_Z = 10\text{mA}$, $\Delta V_Z = 16\text{V to } V_{Ref}$ (2)		-2.7	-1.0	mV/V
Reference Input Current	I_{REF}	$R1 = 10\text{k}\Omega$, $R2 = \infty$, $I_Z = 10\text{mA}^{(2)}$		0.15	0.5	μA
I_{REF} Temperature Deviation	$I_{REF(DEV)}$	$R1 = 10\text{k}\Omega$, $R2 = \infty$, $I_Z = 10\text{mA}^{(2)}$		0.1	0.4	μA
Off-State Cathode Current	$I_{Z(OFF)}$	$V_{REF} = 0\text{V}$, $V_Z = 16\text{V}^{(3)}$ $V_{REF} = 0\text{V}$, $V_Z = 16\text{V}^{(3)}$		0.125 0.135	0.150	μA
Min Operating Current	$I_{Z(MIN)}$	$V_Z = V_{REF}^{(1)}$		20	80	μA
Dynamic Impedance	Z_{KA}	$V_{KA} = V_{ref}$, $I_K = 100\mu\text{A to } 100\text{mA}$, $f \leq 1\text{kHz}$		0.05	0.15	Ω

Electrical Characteristics

Unless specified: $T_A = 25^\circ\text{C}$. Values in bold apply over full operating ambient temperature.

			B431LB 1%			
Parameter	Symbol	Condition	Min	Typ	Max	Units
Reference Voltage	V_{REF}	$V_Z = V_{REF1}$, $I_Z = 10\text{mA}^{(1)}$	1.228	1.240	1.252	V
			1.215		1.265	
V_{REF} Temp Deviation	V_{DEV}	$V_Z = V_{REF1}$, $I_Z = 10\text{mA}^{(1)}$ $I_A = \text{full range}$		10	25	mV
Ratio of Change in V_{REF} To Change in V_Z	$\frac{\Delta V_{REF}}{\Delta V_Z}$	$I_Z = 10\text{mA}$, $\Delta V_Z = 16\text{V}$ to V_{Ref} (2)		-1.0	-2.7	mV/V
Reference Input Current	I_{REF}	$R1 = 10\text{k}\Omega$, $R2 = \infty$, $I_Z = 10\text{mA}^{(2)}$		0.15	0.5	μA
I_{REF} Temperature Deviation	$I_{REF(DEV)}$	$R1 = 10\text{k}\Omega$, $R2 = \infty$, $I_Z = 10\text{mA}^{(2)}$		0.1	0.4	μA
Off-State Cathode Current	$I_{Z(OFF)}$	$V_{REF} = 0\text{V}$, $V_Z = 16\text{V}^{(3)}$		0.125	0.150	μA
		$V_{REF} = 0\text{V}$, $V_Z = 16\text{V}^{(3)}$		0.135	0.150	
Min Operating Current	$I_{Z(MIN)}$	$V_Z = V_{REF}^{(1)}$		20	80	μA
Dynamic Impedance	Z_{KA}	$V_{KA} = V_{ref}$, $I_K = 100\mu\text{A}$ to 100mA , $f \leq 1\text{kHA}$		0.05	0.15	Ω

Electrical Characteristics

Unless specified: $T_A = 25^\circ\text{C}$. Values in bold apply over full operating ambient temperature.

			B431LC 2%			
Parameter	Symbol	Condition	Min	Typ	Max	Units
Reference Voltage	V_{REF}	$V_Z = V_{REF1}$, $I_Z = 10\text{mA}^{(1)}$	1.215	1.240	1.265	V
			1.200		1.280	
V_{REF} Temp Deviation	V_{DEV}	$V_Z = V_{REF1}$, $I_Z = 10\text{mA}^{(1)}$ $I_A = \text{full range}$		10	35	mV
Ratio of Change in V_{REF} To Change in V_Z	$\frac{\Delta V_{REF}}{\Delta V_Z}$	$I_Z = 10\text{mA}$, $\Delta V_Z = 16\text{V}$ to V_{Ref} (2)		-1.0	-2.7	mV/V
Reference Input Current	I_{REF}	$R1 = 10\text{k}\Omega$, $R2 = \infty$, $I_Z = 10\text{mA}^{(2)}$		0.15	0.5	μA
I_{REF} Temperature Deviation	$I_{REF(DEV)}$	$R1 = 10\text{k}\Omega$, $R2 = \infty$, $I_Z = 10\text{mA}^{(2)}$		0.1	0.4	μA
Off-State Cathode Current	$I_{Z(OFF)}$	$V_{REF} = 0\text{V}$, $V_Z = 16\text{V}^{(3)}$		0.125	0.150	μA
		$V_{REF} = 0\text{V}$, $V_Z = 16\text{V}^{(3)}$		0.135	0.150	
Min Operating Current	$I_{Z(MIN)}$	$V_Z = V_{REF}^{(1)}$		20	80	μA
Dynamic Impedance	Z_{KA}	$V_{KA} = V_{ref}$, $I_K = 100\mu\text{A}$ to 100mA , $f \leq 1\text{kHA}$		0.05	0.15	Ω

Cathode Current vs. Cathode Voltage

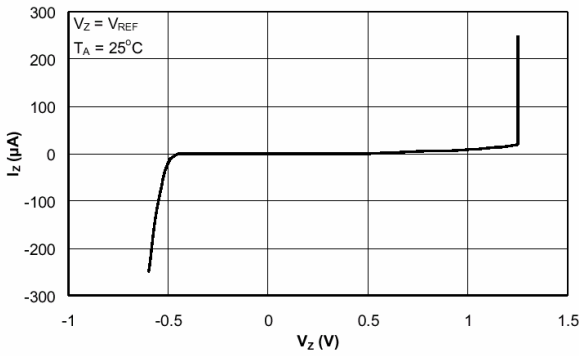

Cathode Current vs. Cathode Voltage

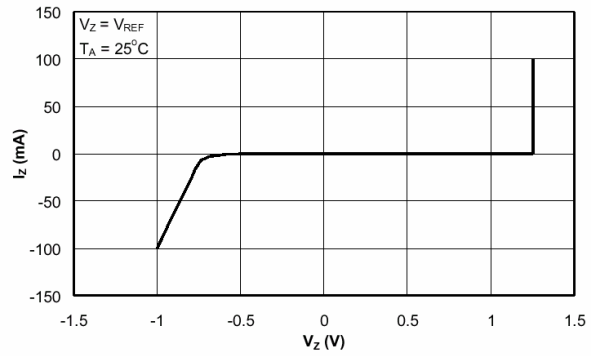

Reference Voltage vs. Junction Temperature

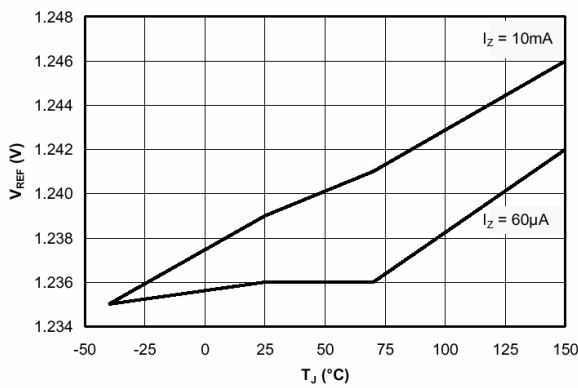

Reference Input Current vs. Junction Temperature

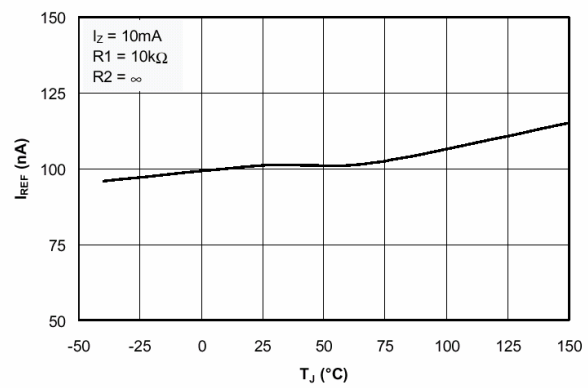

Ratio of Delta Reference Voltage to Delta Cathode Voltage vs. Junction Temperature

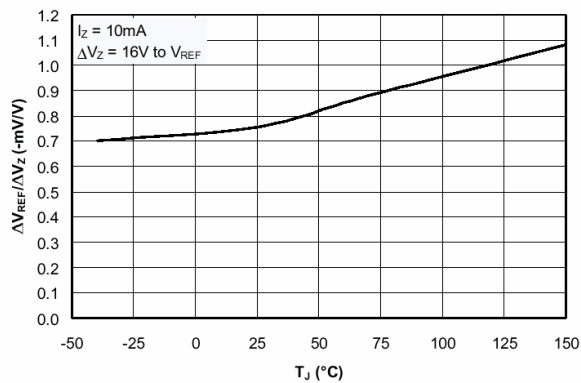

Off-State Cathode Current vs. Junction Temperature

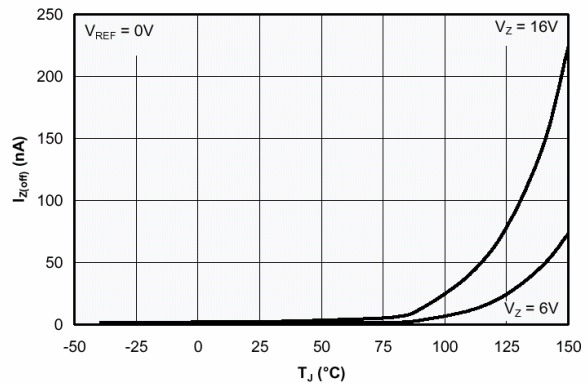

Reference Impedance vs. Junction Temperature

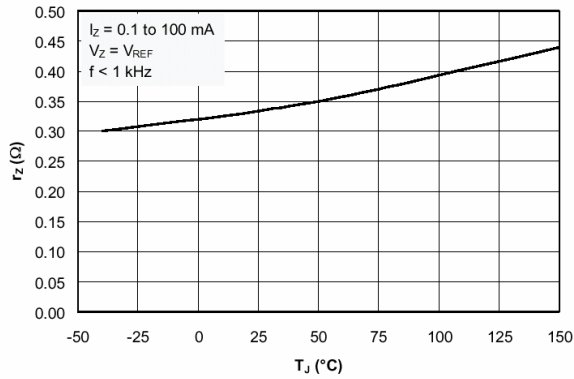

Reference Impedance vs. Frequency

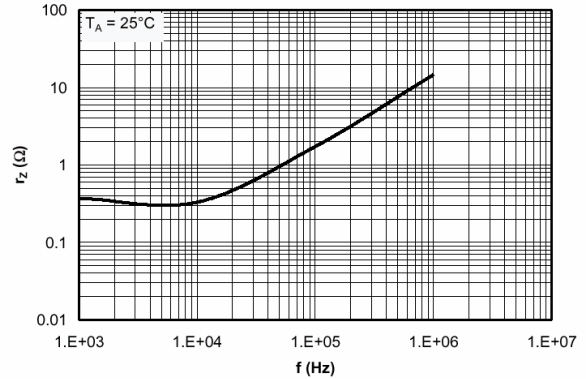

Small-Signal Gain and Phase Shift vs. Frequency

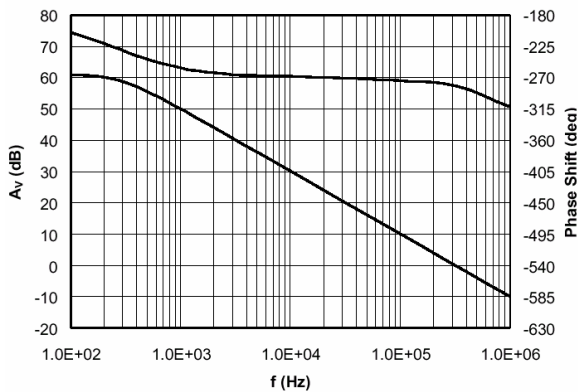

Test Circuit: Small-Signal Gain & Phase

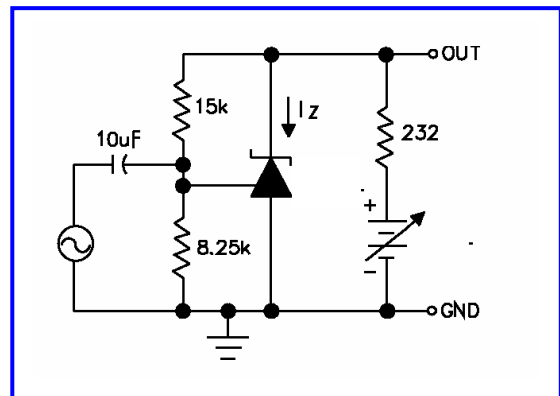

Stability Boundary Condition For Shunt Regulation vs. Cathode Current and Load Capacitance

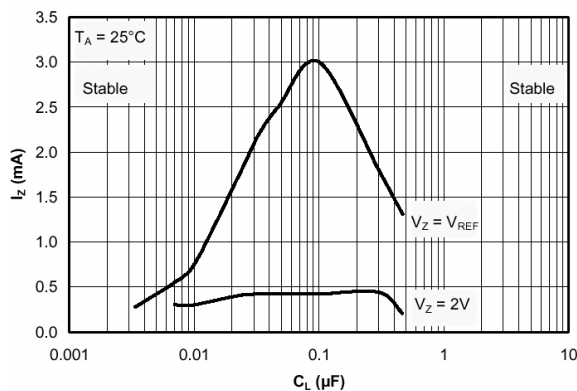

Test Circuit: Stability

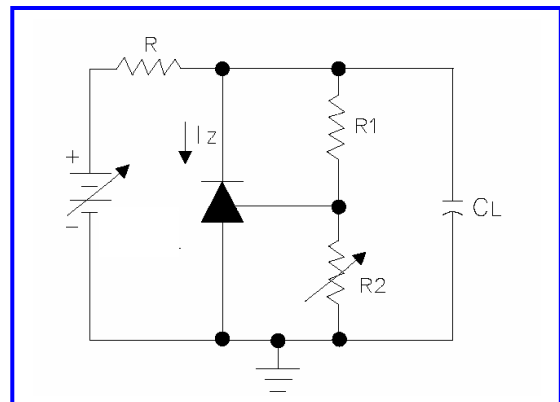

Application Notes:

1) Set V_{OUT} according to the following equation:

$$V_{OUT} = V_{REF} \left(1 + \frac{R1}{R2} \right) + I_{REF} R1$$

2) Choose the value for R as follows:

- The maximum limit for R should be such that the cathode current, I_z , is greater than the minimum operating current (80 μ A) at $V_{IN(MIN)}$.
- The minimum limit for R should be such that I_z does not exceed 100mA under all load conditions, and the instantaneous turn-on value for I_z does not exceed 150mA. Both of the following conditions must be met:

$$R_{min} \geq \frac{V_{IN(max)}}{150 \text{ mA}} \quad (\text{to limit instantaneous turn-on } I_z)$$

$$R_{min} \geq \frac{V_{IN(max)} - V_{OUT}}{I_{OUT(min)} + 100 \text{ mA}} \quad (\text{to limit } I_z \text{ under normal})$$

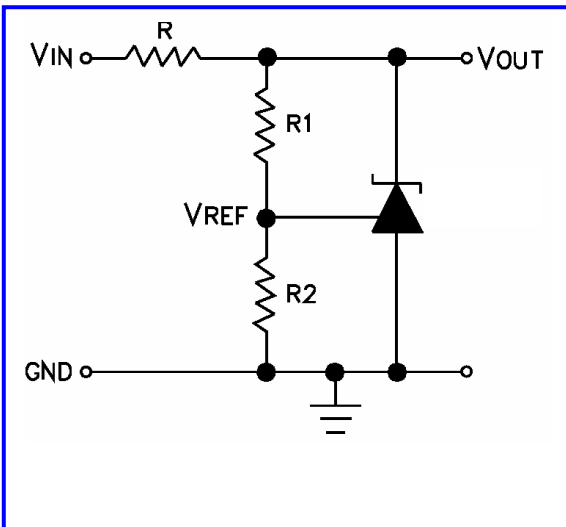

Stability: Selection of Load Capacitor

Selection of load capacitor for when B431L is used as a shunt regulator, two options for selection of C_L 1) No load capacitance across the device, decouple at the load 2) Large capacitance across the device, optional decoupling at the load.

The reason for this is that B431L exhibits instability with capacitances in the range of 10nF to 1 μ F (approx.) at light cathode currents (up to 3mA typical). The device is less stable the lower the cathode voltage has been set for. Therefore while the device will be perfectly stable operating at a cathode current of 10mA with a 0.1 μ F capacitor across it, it will oscillate transiently during start-up as the cathode current passes through the instability region. Selecting a very low (or preferably, no) capacitance, or alternatively a high capacitance such as 10 μ F will avoid this issue altogether. Since the user anyway, the most cost effective method is to use no capacitance at all directly across the device. PCB trace/via resistance and inductance prevent the local load decoupling from causing the oscillation during the transient start-up phase.

Note: if the B431L is located right at the load, so the load decoupling capacitor is directly across it, then this capacitor will have to be ≤ 1 nF or $\geq 10\mu$ F

Test Circuits:

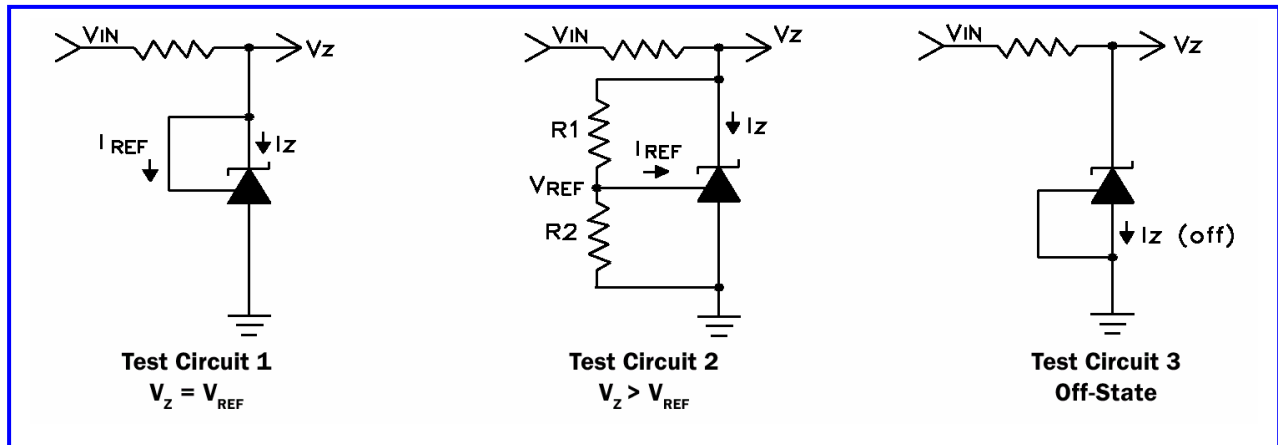

Application Circuit:

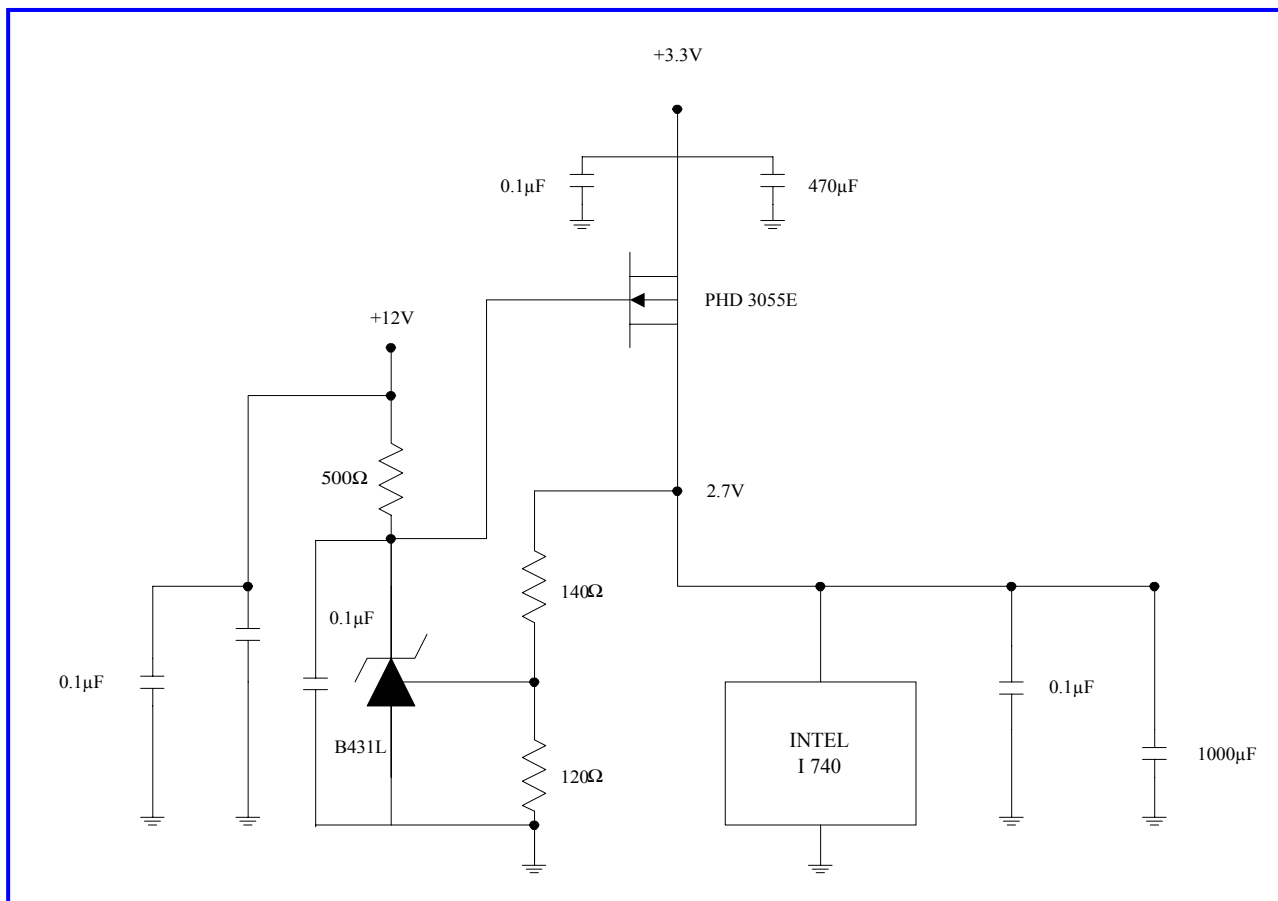

*If the output voltage has noise, then please add a 0.1μF in between drain and gate of power MOSFET to reduce the noise.

SOT-23

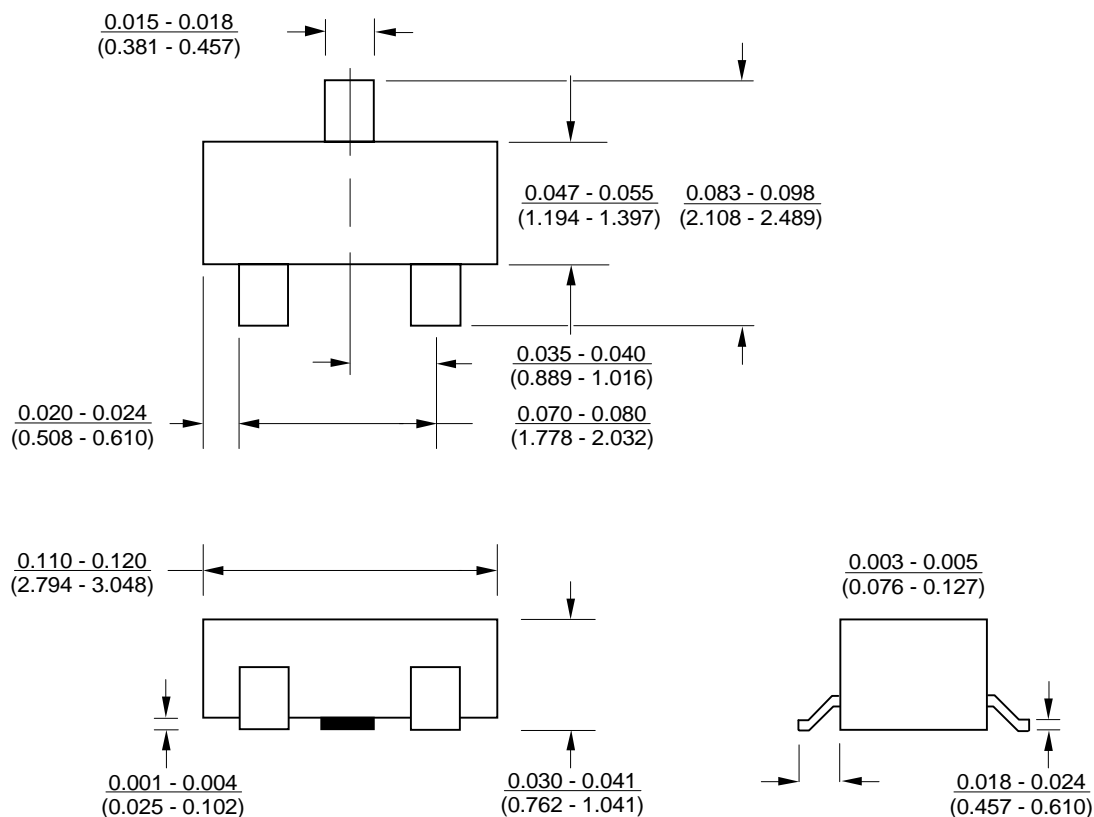

Advance Information- These data sheets contain descriptions of products that are in development. The specifications are based on the engineering calculations, computer simulations and/or initial prototype evaluation.

Preliminary Information- These data sheets contain minimum and maximum specifications that are based on the initial device characterizations. These limits are subject to change upon the completion of the full characterization over the specified temperature and supply voltage ranges.

The application circuit examples are only to explain the representative applications of the devices and are not intended to guarantee any circuit design or permit any industrial property right to other rights to execute. Bay Linear takes no responsibility for any problems related to any industrial property right resulting from the use of the contents shown in the data book. Typical parameters can and do vary in different applications. Customer's technical experts must validate all operating parameters including "Typical" for each customer application.

LIFE SUPPORT AND NUCLEAR POLICY

Bay Linear products are not authorized for and should not be used within life support systems which are intended for surgical implants into the body to support or sustain life, in aircraft, space equipment, submarine, or nuclear facility applications without the specific written consent of Bay Linear President.
