

AZ852

MICROMINIATURE POLARIZED RELAY

FEATURES

- Conforms to IEC60950/UL60950/EN60950 spacing and high breakdown voltage
Supplementary insulation
mains voltage 250 Vrms (SMT); 200 Vrms (THT)
Pollution Degree 2 (external); 1 (internal)
- Monostable and bistable (latching) coil versions available
- High dielectric and surge voltage:
2.5 KV surge (per Bellcore TA-NWT-001089)
2.5 KV surge (per FCC Part 68)
1,000 Vrms, open contacts
- Stable contact resistance for low level signal switching
- Epoxy sealed
- UL, CUR pending



CONTACTS

Arrangement	DPDT (2 Form C) Bifurcated crossbar contacts
Ratings	Resistive load: Max. switched power: 60 W or 62.5 VA Max. switched current: 2.0 A Max. switched voltage: 220 VDC* or 250 VAC * Note: If switching voltage is greater than 30 VDC, special precautions must be taken. Please contact the factory.
Rated Load UL/CUR	0.5 A at 125 VAC 2.0 A at 30 VDC 0.24 A at 220 VDC
Material	Palladium Ruthenium; gold clad
Resistance	< 50 milliohms initially at 20 mV, 10 mA

COIL (Polarized)

Power At Pickup Voltage (typical)	79 mW (3–12 VDC) 98 mW (24 VDC)
Max. Continuous Dissipation	0.73 W at 20°C (68°F)
Temperature Rise	At nominal coil voltage 21°C (38°F) (3–12 VDC) 30°C (54°F) (24 VDC)
Temperature	Max. 115°C (239°F)

NOTES

1. All values at 20°C (68°F).
2. Relay may pull in with less than "Must Operate" value.
3. Relay has fixed coil polarity.
4. Specifications subject to change without notice.
5. Ultrasonic cleaning is not recommended.

GENERAL DATA

Life Expectancy Mechanical Electrical	Minimum operations 1 x 10 ⁸ 1 x 10 ⁵ at 0.5 A, 125 VAC, Res. 1 x 10 ⁵ at 2.0 A, 30 VDC, Res.
Operate Time (typical)	1 ms at nominal coil voltage
Release Time (typical)	1 ms at nominal coil voltage (with no coil suppression)
Bounce (typical)	At 10 mA contact current 1 ms at operate or release
Capacitance	< 2 pF at 10 KHz - coil to contacts < 1 pF at 10 KHz - between open contacts < 2 pF at 10 KHz - between contact sets
Dielectric Strength (at sea level)	See table
Dropout	Greater than 10% of nominal coil voltage
Insulation Resistance	10 ⁹ ohms min. at 25°C, 500 VDC, 50% RH
Ambient Temperature Operating Storage	At nominal coil voltage -40°C (-40°F) to 85°C (185°F) -40°C (-40°F) to 105°C (221°F)
Vibration	Operational, 20 g, 10–1,000 Hz
Shock	Operational, 50 g min., 11 ms Non-destructive, 500 g min., 0.5 ms
Enclosure	P.B.T. polyester, UL 94 V-0
Terminals	Tinned copper alloy, P.C.
Max. Solder Temp.	260°C (500°F)
Max. Solder Time	10 seconds
Weight	0.8 grams
Packing unit in pcs	50 per plastic tube, 1000 per carton box 1000 per reel, 1000 or 5000 per carton box

ZETTLER electronics GmbH

Junkersstrasse 3, D-82178 Puchheim, Germany

Tel. +49 89 800 97 0
Fax +49 89 800 97 200

office@ZETTLERelectronics.com
www.ZETTLERelectronics.com

2005-03-11

EU

AZ852

RELAY ORDERING DATA

NON-LATCHING VERSION				ORDER NUMBER		
Nominal Coil VDC	Must Operate VDC	Max. Continuous VDC	Coil Resistance Ohm $\pm 10\%$	THT	Gull Wing*	J-Leg*
1.5	1.13	3.4	16	AZ852N-1.5DE	AZ852G-1.5DE	AZ852J-1.5DE
3	2.10	6.8	64	AZ852N-3DE	AZ852G-3DE	AZ852J-3DE
4.5	3.15	10.3	145	AZ852N-4.5DE	AZ852G-4.5DE	AZ852J-4.5DE
5	3.50	11.4	178	AZ852N-5DE	AZ852G-5DE	AZ852J-5DE
6	4.20	13.7	257	AZ852N-6DE	AZ852G-6DE	AZ852J-6DE
9	6.30	20.4	574	AZ852N-9DE	AZ852G-9DE	AZ852J-9DE
12	8.40	27.3	1,028	AZ852N-12DE	AZ852G-12DE	AZ852J-12DE
24	16.80	45.6	2,880	AZ852N-24DE	AZ852G-24DE	AZ852J-24DE

LATCHING VERSION				ORDER NUMBER		
Nominal Coil VDC	Must Operate VDC	Max. Continuous VDC	Coil Resistance Ohm $\pm 10\%$	THT	Gull Wing*	J-Leg*
1.5	1.13	4.1	23	AZ852PN-1.5DE	AZ852PG-1.5DE	AZ852PJ-1.5DE
3	2.25	8.1	90	AZ852PN-3DE	AZ852PG-3DE	AZ852PJ-3DE
4.5	3.38	12.1	203	AZ852PN-4.5DE	AZ852PG-4.5DE	AZ852PJ-4.5DE
5	3.75	13.5	250	AZ852PN-5DE	AZ852PG-5DE	AZ852PJ-5DE
6	4.50	16.2	360	AZ852PN-6DE	AZ852PG-6DE	AZ852PJ-6DE
9	6.75	24.2	810	AZ852PN-9DE	AZ852PG-9DE	AZ852PJ-9DE
12	9.00	32.3	1,440	AZ852PN-12DE	AZ852PG-12DE	AZ852PJ-12DE
24	18.00	41.9	2,880	AZ852PN-24DE	AZ852PG-24DE	AZ852PJ-24DE

* Available only in Tape and Reel available (1K pcs/reel minimum)

	SURGE			
	VRMS, 1 min.	Peak (V)	Rise Time (μ s)	Decay Time* (μ s) (1/2 peak)
Between open contacts	1,000	1,500	2 (10)	10 (160)
Between contact sets	1,000	1,500	2 (10)	10 (160)
Between coil and contacts	1,800	2,500	2 (10)	10 (160)

* Decay time measured from beginning of surge.

Temperature Profile

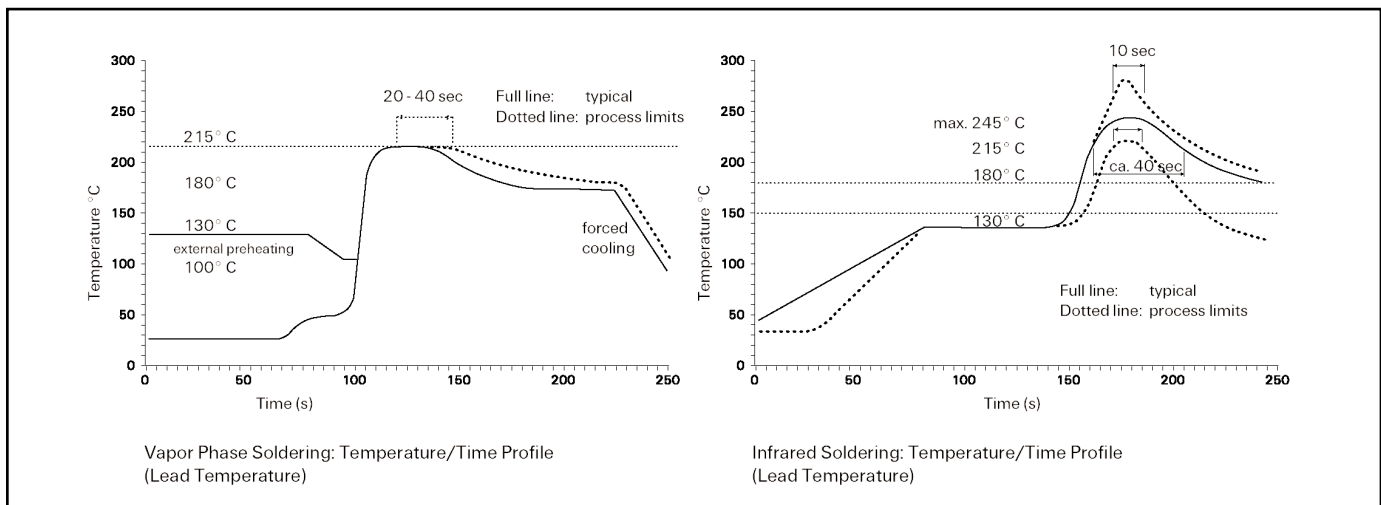

Recommended Soldering Profile according CECC 00802

ZETTLER electronics GmbH

Junkersstrasse 3, D-82178 Puchheim, Germany

Tel. +49 89 800 97 0

Fax +49 89 800 97 200

office@ZETTLERelectronics.com

www.ZETTLERelectronics.com

2005-03-11

EU

AZ852

MECHANICAL DATA

	PC BOARD LAYOUT	WIRING DIAGRAM
<p>Narrow Version</p>	<p>Narrow Version</p>	<p>Non-latching type not energized condition</p> <p>TOP VIEW</p>
<p>Gull Wings</p>	<p>Gull Wings</p>	<p>Latching type, 1 coil RESET condition</p> <p>TOP VIEW</p>
<p>J Legs</p>	<p>J Legs</p> <p>VIEWED TOWARD TERMINALS</p>	

DIMENSIONS

	NARROW		GULL WINGS		J-LEGS	
	mm	inch	mm	inch	mm	inch
L	10 ±0.08	0.393 ±0.003	10 ±0.08	0.393 ±0.003	10 ±0.08	0.393 ±0.003
W	5.7 ±0.3	0.224 ±0.012	6 ±0.08	0.236 ±0.003	6 ±0.08	0.236 ±0.003
H	5.85 -0.15	0.230 -0.006	5.65 -0.2	0.222 -0.008	5.65 -0.2	0.222 -0.008
T	3.2	0.125	N/A	N/A	N/A	N/A
T1	N/A	N/A	7.5 ±0.3	0.295 ±0.011	2.8 ±0.2	0.110 ±0.007
T2	3.2 ±0.1	0.126 ±0.006	5.08 ±0.1	0.200 ±0.004	5.08 ±0.1	0.200 ±0.004
D1	3.2 ±0.15	0.126 ±0.006	3.2 ±0.15	0.126 ±0.006	3.2 ±0.15	0.126 ±0.006
D2	2.2 ±0.15	0.087 ±0.006	2.2 ±0.15	0.087 ±0.006	2.2 ±0.15	0.087 ±0.006
Tw	0.4	0.015	0.4	0.015	0.4	0.015
S	0.3 ±0.05	0.011 ±0.002	N/A	N/A	N/A	N/A

ZETTLER electronics GmbH

Junkersstrasse 3, D-82178 Puchheim, Germany

Tel. +49 89 800 97 0
Fax +49 89 800 97 200

office@ZETTLERelectronics.com
www.ZETTLERelectronics.com

2005-03-11

EU

AZ852

Packaging Specifications

Tape and reel for SMT version - 1000 relays per reel, 1000 or 5000 relays per box

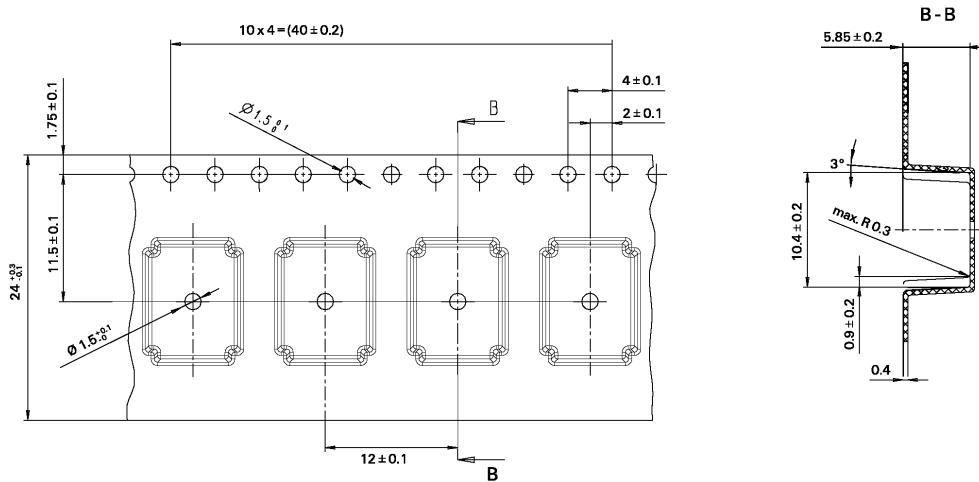

Reel dimension

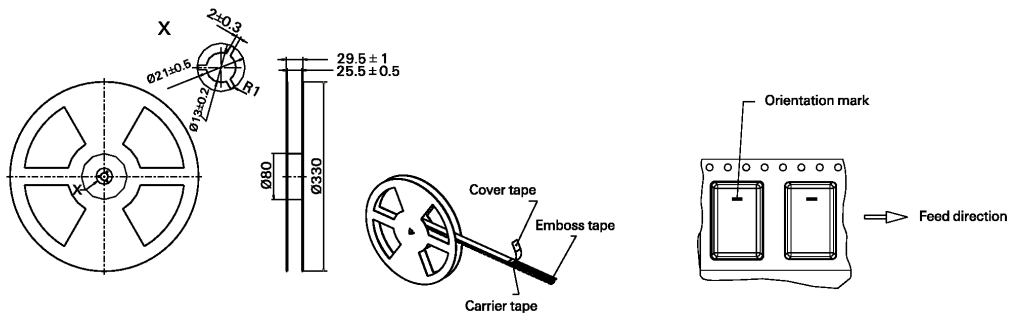

Tube for THT version - 50 relays per tube, 1000 relays per box

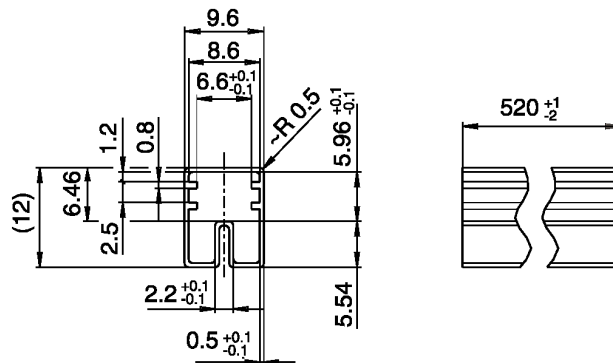

ZETTLER electronics GmbH

Junkersstrasse 3, D-82178 Puchheim, Germany

Tel. +49 89 800 97 0
Fax +49 89 800 97 200

office@ZETTLERelectronics.com
www.ZETTLERelectronics.com

2005-03-11

EU