

ASM0406C

DATA SHEET

APLUS INTEGRATED CIRCUITS INC.

Address:

3 F-10, No. 32, Sec. 1, Chenggung Rd., Taipei,
Taiwan 115, R.O.C.
(115)台北市南港區成功路一段 32 號 3 樓之 10.

TEL: 886-2-2782-9266

FAX: 886-2-2782-9255

WEBSITE : <http://www.aplusinc.com.tw>

Sales E-mail: Mr. Jason

sales@aplusinc.com.tw

Technology E-mail: Mr. George

service@aplusinc.com.tw

ASM0406C — VERY LOW-COST VOICE SYNTHESIZER WITH 4-BIT MICROPROCESSOR

1.0 General Description

The ASM0406C is very low cost voice synthesizer with 4-bit microprocessor. It has various features including 4-bit ALU, ROM, RAM, I/O ports, timers, clock generator, watchdog timer(WDT), voice synthesizer, etc. It consists of 22 instructions in the device. With CMOS technology and halt function can minimize power dissipation. Its architecture is similar to RISC, with two stages of instruction pipeline. It allows all instructions to be executed in a single cycle, except for program branches and data table read instructions (which need two instruction cycles).

1.1 Feature

- ◆ Single power supply can operate from 2.4V through 5V
- ◆ Internal Program ROM: 4K x 10-bit
- ◆ 1 sets of 15-bit DPR can access up to 16K x 10 bits data memory space
- ◆ Data Registers:
 - 64 x 4-bit data RAM (00-1Fh plus 40h-5Fh)
 - Unbanked special function registers (SFR) range: 20h-3Fh
- ◆ I/O Ports:
 - PRA: 4-bit I/O Port A (2Bh)
 - PRB: 2-bit Output Port B (2Dh)
- ◆ On-chip clock generator: Resistive Clock Drive(**RM**)
- ◆ Timer: 1
 - Timer0: a 9-bit auto-reload timer/counter
- ◆ Stack: 2-level subroutine nesting
- ◆ HALT and Release from HALT function to reduce power consumption
- ◆ Watch Dog Timer (**WDT**)
- ◆ Instruction: 1-cycle instruction except for table read and program branches which are 2-cycles
- ◆ Number of instruction: 22
- ◆ The Voice function can be implemented by microprocessor instruction
 - One 8-bit COUT output for ASMxxxxx

FIGURE 1.1 : Block Diagram of ASM0406C

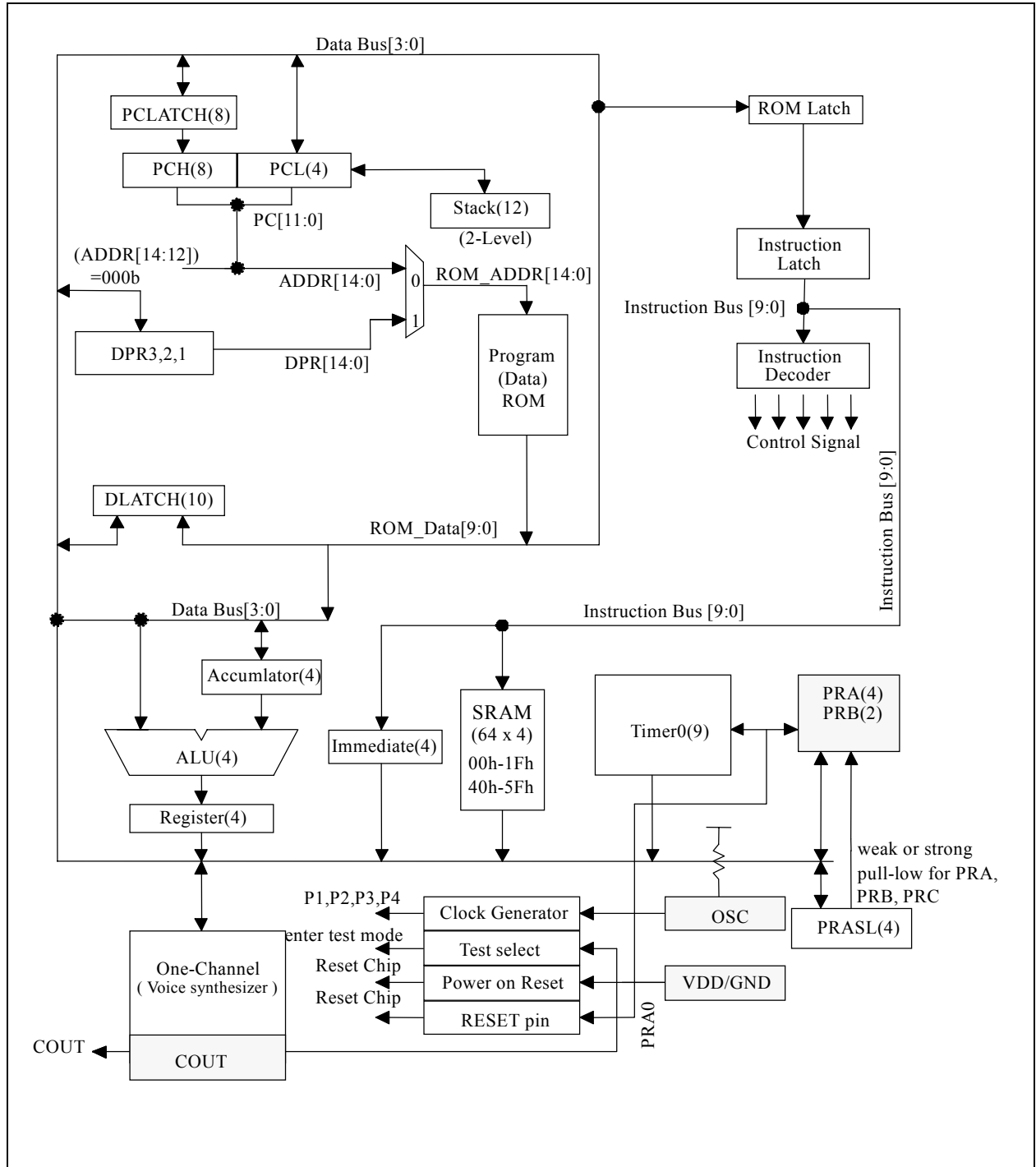
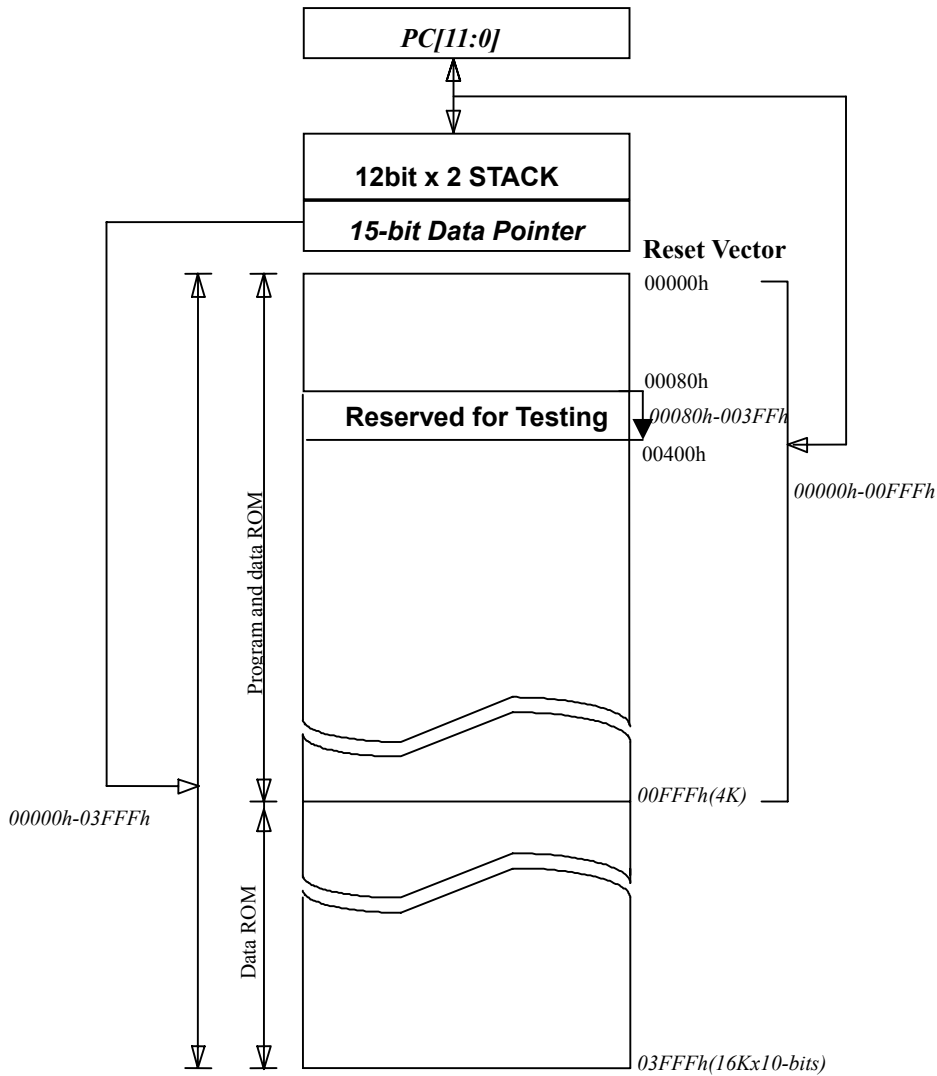

FIGURE 1.2 : External ROM Map of ASM0406C



1.2 Pin-Out

| ASM0406C Pin-Out | | | |
|------------------|-----|---------------|--|
| VDD | I | - | Power supply during operation |
| PRA3-1 | I/O | ST1 Std./O.D. | I/O port with programmable strong pull-low or weak pull-low or fix-input-floating capability Output type with standard or Open-Drain output |
| PRA0/RESET | I/O | ST1 Std./O.D. | I/O port with programmable strong pull-low or weak pull-low or fix-input-floating capability Output type with standard or Open-Drain output <i>Mask option selected as an external RESET pin with weak pull-low capability</i> |
| OSC | I | - | RM mode Oscillator input |
| COUT | O | - | Current Output of Audio |
| GND | I | - | Circuit Ground Potential |
| TEST | O | - | Enter Test Mode. (TEST = High) |
| PRB0-1 | O | Std./O.D. | Output type with standard or Open-Drain output |

1.3 Application circuit

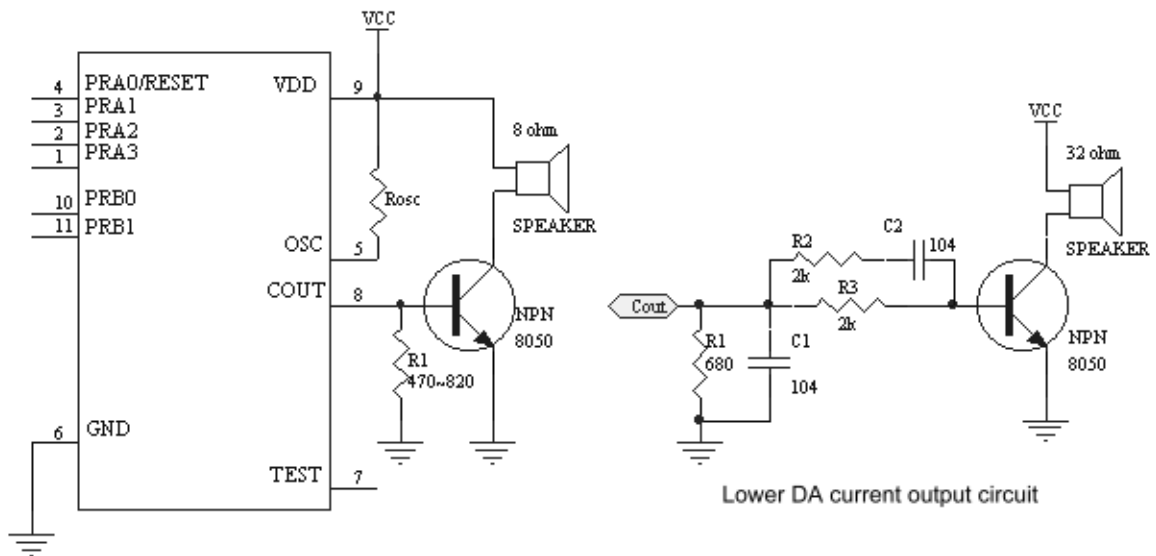

1.4 Bonding Diagram

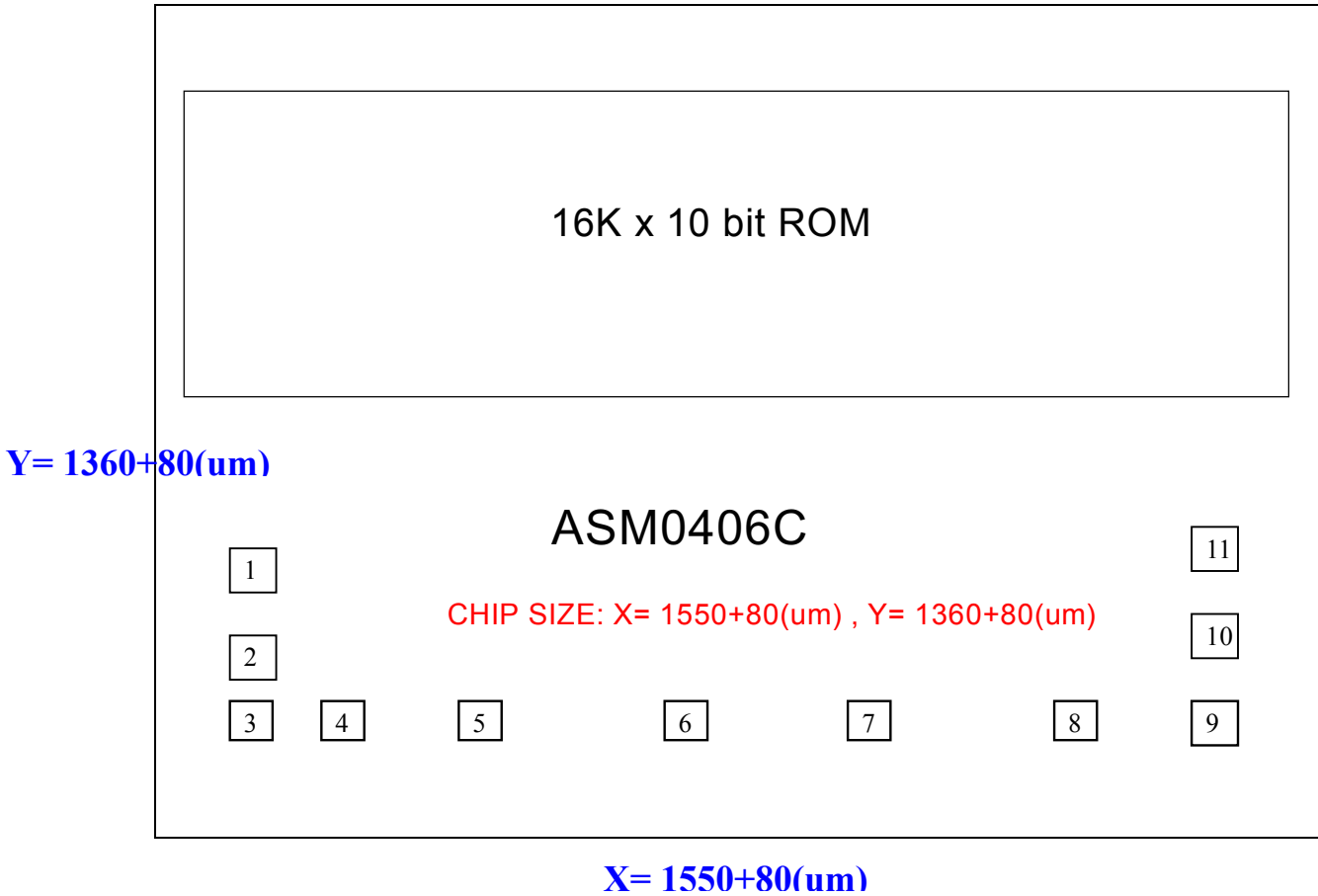

Substrate must be connected to GND.

| ASM0406C Pad Location | | | | Chip Size: X= 1550 + 80 (um), Y=1360 + 80 (um) | | | |
|-----------------------|----------|---------|---------|--|----------|--------|--------|
| PAD # | PAD Name | X | Y | PAD # | PAD Name | X | Y |
| 1 | RA3 | -664.92 | -275.52 | 7 | TEST | 105.44 | -600.2 |
| 2 | RA2 | -664.92 | -403.64 | 8 | COUT | 303.96 | -600.2 |
| 3 | RA1 | -662.64 | -600.2 | 9 | VDD | 683.04 | -600.2 |
| 4 | RA0 | -468.24 | -600.2 | 10 | RB0 | 664.92 | -399.2 |
| 5 | OSC | -281.04 | -600.2 | 11 | RB1 | 664.92 | -280.8 |
| 6 | GND | -111.72 | -600.2 | | | | |

1.5 DC Characteristics for ASMxxxxx

| SYMBOL | PARAMETER | | VDD | MIN. | TYP. | MAX. | UNIT | CONDITION |
|--------|-------------------------------------|-----------|-----|------|------|------|------|--|
| VDD | OPERATING VOLTAGE | | | 2.4 | 3 | 5.0 | V | depending on Freq. |
| Isb | SUPPLY CURRENT | STANDBY | 3 | | | 1 | uA | 4MHz, RM in HALT Mode |
| | | | 5 | | | 1 | | |
| Iop | | OPERATING | 3 | | 2 | | mA | 4MHz, RM IO Floating |
| | | | 5 | | 7 | | | |
| lih | INPUT CURRENT /Internal pull low | | 3 | | 3 | | uA | 4MHz, RM in HALT Mode (IO Ports with weak pull-high pull-low) |
| | | | 5 | | 9 | | | |
| | | | 5 | | -5.2 | | | |
| Ioh | OUTPUT HIGH CURRENT | | 3 | | -3 | | mA | 4MHz, RM (IO ports) |
| | | | 5 | | -8 | | | |
| Iol | OUTPUT LOW CURRENT | | 3 | | 7 | | mA | 4MHz, RM (IO ports) |
| | | | 5 | | 20 | | | |
| Cout | DA CURRENT OUT (FULL SCALE) | | 3 | | 4 | | mA | 4MHz, RM (IO ports) |
| | | | 5 | | 5.2 | | | |
| dF/F | FREQUENCY STABILITY | | | -10 | | 10 | % | $\frac{F_{osc}(3v-2.4v)}{F_{osc}(3v)}$ |
| dF/F | Fosc VARIATION | | | -20 | | 20 | % | VDD=3V, Rosc=850k, 4MHz |

FIGURE 1.3 : Frequency Range for Rosc in RM mode

| | | | | |
|-----------------|------|------|------|------|
| Resistor(k ohm) | 1200 | 1000 | 820 | 560 |
| 3v Freq.(MHz) | 2.92 | 3.51 | 4.13 | 7.02 |

