

AZ DISPLAYS, INC.

COMPLETE LCD SOLUTIONS

SPECIFICATIONS FOR LIQUID CRYSTAL DISPLAY

PART NUMBER:
DATE:

AGM2464E SERIES
January 24, 2003

AGM2464E SERIES GRAPHIC MODULE
1.0 MECHANICAL DIAGRAM

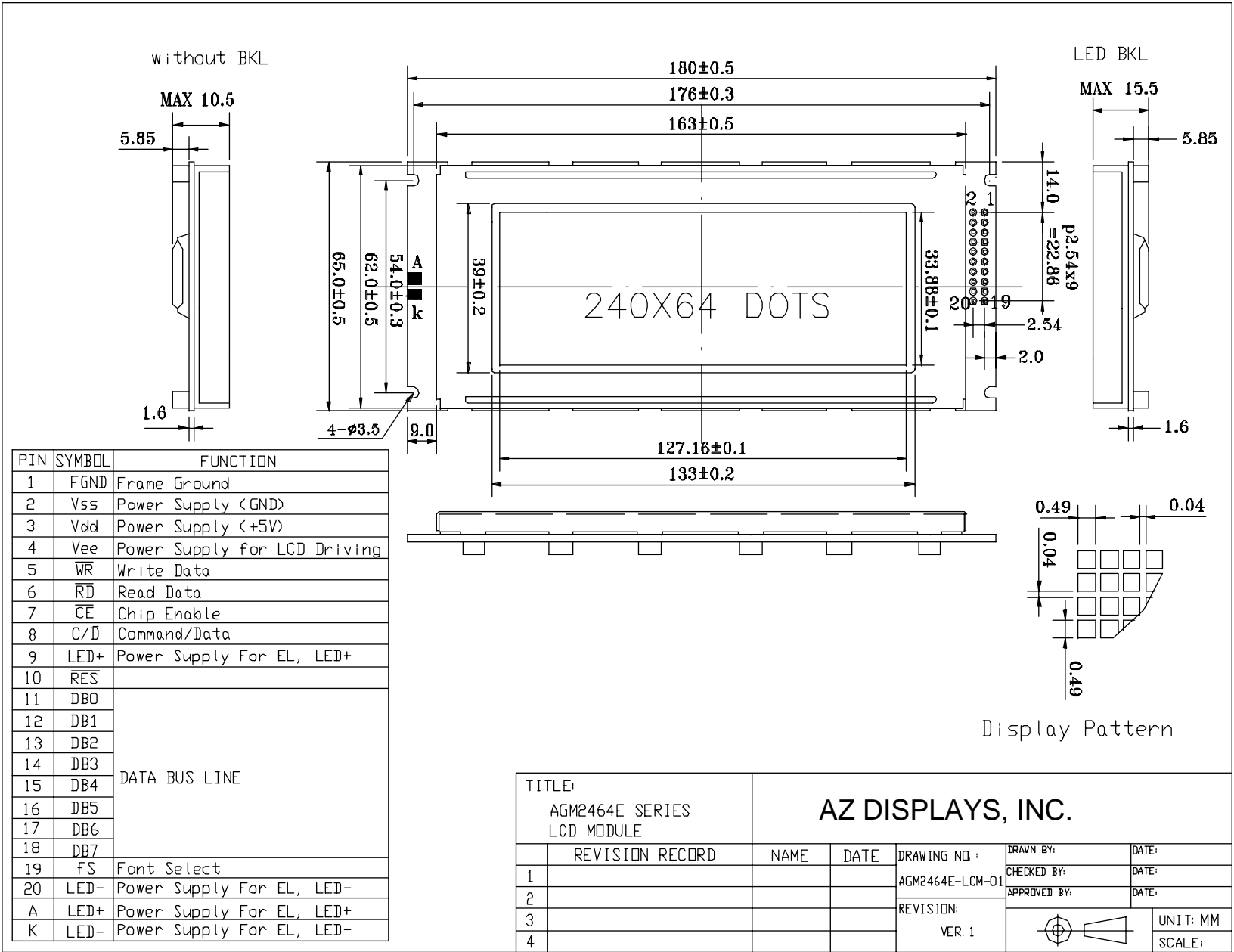

AGM2464E SERIES GRAPHIC MODULE

2.0 MECHANICAL SPECS

1. Overall Module Size	180.0mm(W) x 65.0mm(H) x max 15.5mm(D) for LED backlight version 180.0mm(W) x 65.0mm(H) x max 10.5mm(D) for reflective version
2. Dot Size	0.49mm(W) x 0.49mm(H)
3. Dot Pitch	0.53mm(W) x 0.53mm(H)
4. Duty	1/64
5. Controller IC	T6963C
6. LC Fluid Options	STN, FSTN
7. Polarizer Options	Reflective, Transflective, Transmissive
8. Backlight Options	EL, LED
9. Temperature Range Options	Standard (0°C ~ 50°C), Wide (-20°C ~ 70°C)

3.0 ABSOLUTE MAXIMUM RATINGS

Item	Symbol	Min	Typ	Max	Unit
Operating temperature (Standard)	Top	0	-	50	°C
Storage temperature (Standard)	Tst	-20	-	70	°C
Operating temperature (Wide temperature)	Top	-20	-	70	°C
Storage temperature (Wide temperature)	Tst	-30	-	80	°C
Input voltage	Vin	-0.3	-	Vdd+0.3	V
Supply voltage for logic	Vdd- Vss	-0.3	-	7.0	V
Supply voltage for LCD drive	Vdd- Vo	11.0	12.5		V

AGM2464E SERIES GRAPHIC MODULE

4.0 ELECTRICAL CHARACTERISTICS

Item	Symbol	Condition	Min	Typ	Max	Unit
Input voltage (high)	Vih	H level	3.5	-	Vdd	V
Input voltage (low)	Vil	L level	0	-	1.5	V
Recommended LC Driving Voltage (Standard Temp)	Vdd - Vo	0C	12.5	12.8	-	V
		25C	12.1	12.5	-	
		50C	11.6	12.2	-	
Recommended LC Driving Voltage (Wide Temp)	Vdd -Vo	-20C	12.8	13.2	-	V
		0C	12.5	12.8	-	
		50C	11.8	12.2	-	
		70C	11.3	11.8	-	
Power Supply Current	Idd	Vdd=5.0V	-	10	16.0	mA
LED Power Supply Voltage	Vfled	R=5.0Ω	-	4.2	4.4	V
LED Power Supply Current	Ifled	R=5.0Ω	-	510	850	mA

5.0 OPTICAL CHARACTERISTICS

Item Mode		Cr (Contrast Ratio)		θ (Viewing Angle)		φ (Viewing Angle)	
		25C		25 C		25 C	
		MIN.	TYP.	MIN	TYP.	MIN	TYP.
R	A	2.8	3.05	80	85	-	35
	B	7.10	7.70	80	85	-	35
	C	-	-	-	-	-	-
S	A	2.49	2.99	80	85	-	35
	B	7.05	7.55	80	85	-	35
	C	-	-	-	-	-	-

Note:

- R: Reflective
- S: Transflective
- A: STN Gray
- B: STN Yellow
- C: FSTN

AGM2464E SERIES GRAPHIC MODULE

Item	Symbol	Condition	Min	Typ	Max	Unit
Response time (rise)	Tr	25 °C	-	150	250	ms
Response time (fall)	Tf	25°C	-	150	250	ms

6.0 BLOCK DIAGRAM

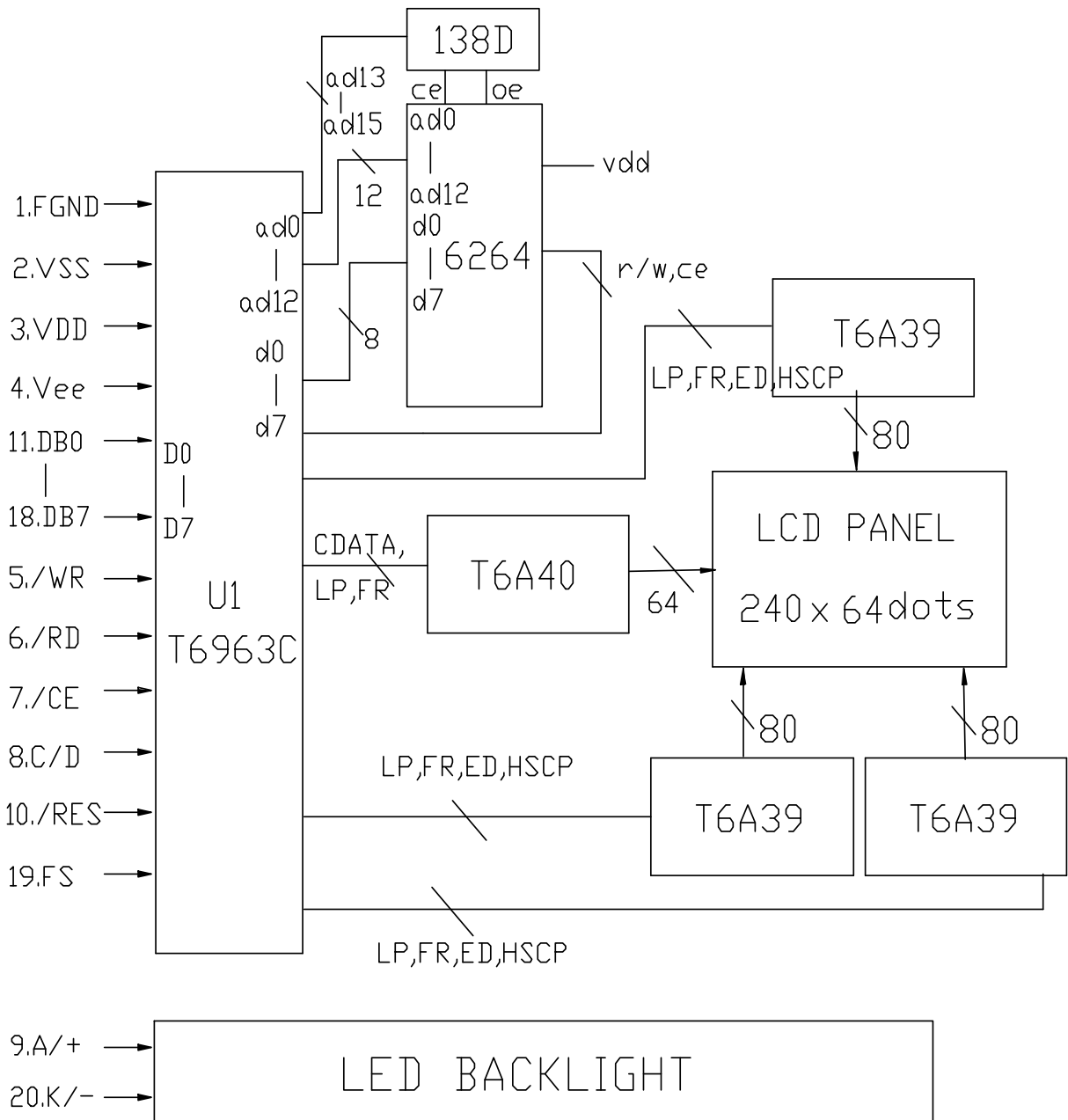

AGM2464E SERIES GRAPHIC MODULE

7.0 PIN ASSIGNMENT

Pin No.	Symbol	Function	Level
1	FGND	Frame Ground	-
2	V _{SS}	Ground	-
3	V _{DD}	+5V	-
4	V _{ee}	Power supply for LCD driving	-
5	/WR	H: Data read L: Data write	L
6	/RD	Enable signal	L
7	/CE	Chip Enable	L
8	C/D	Command/Data	L/H
9	A/+	Power Supply for BL +	-
10	/RES	Reset	H/L
11	DB0	Data bit 0	H/L
12	DB1	Data bit 1	H/L
13	DB2	Data bit 2	H/L
14	DB3	Data bit 3	H/L
15	DB4	Data bit 4	H/L
16	DB5	Data bit 5	H/L
17	DB6	Data bit 6	H/L
18	DB7	Data bit 7	H/L
19	FS	Font Select	H/L
20	K/-	Power Supply for BL -	-

8.0 POWER SUPPLY

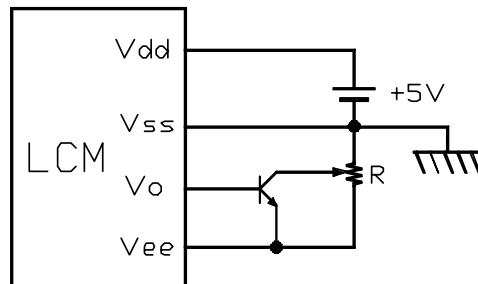

R=10K~20Kohms

AGM2464E SERIES GRAPHIC MODULE

9.0 TIMING CHARACTERISTICS

(1) Bus Timing ($T_A=0-50\text{deg.C}$, $V_{DD}=5V \pm 10\%$ $V_{SS}=0V$)

Item	Symbol	Min.	Max.	Unit
C/D set up time	T_{CDS}	100	-	ns
C/D hold time	T_{CDH}	10	-	ns
CE,RD,WR Pulse Width	T_{CE}, T_{RD}, T_{WR}	80	-	ns
Data set up time	T_{DS}	80	-	ns
Data hold time	T_{DH}	40	-	ns
Access time	T_{acc}	-	150	ns
Output Hold time	T_{OH}	10		ns

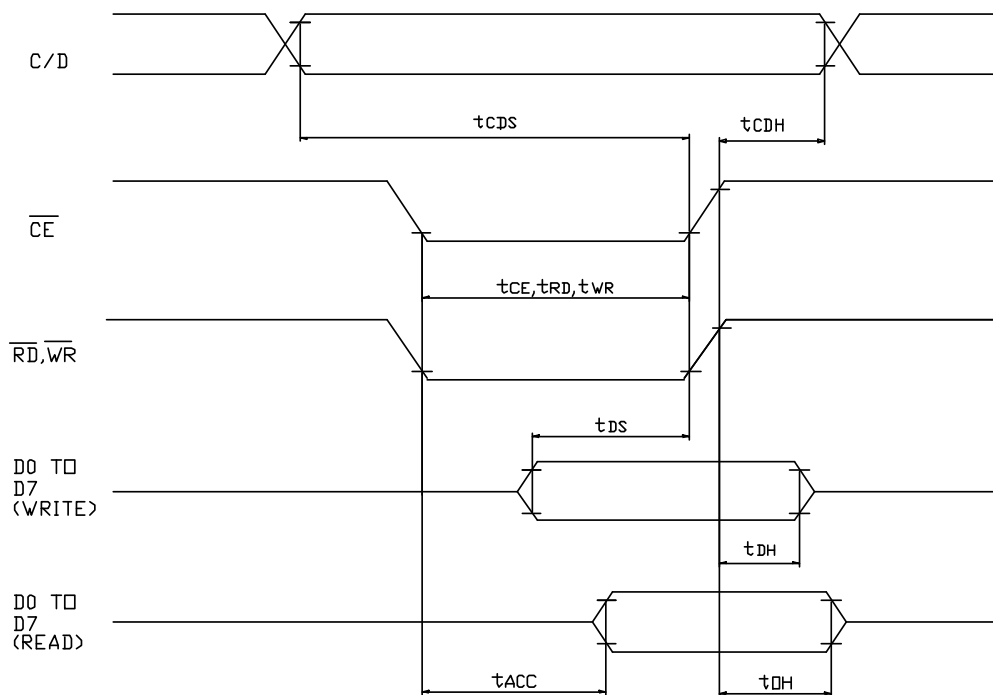

(2) Serial interface Timing ($T_A=0-50\text{deg.C}$, $V_{DD}=5V \pm 10\%$ $V_{SS}=0V$)

Item	Symbol	Min.	Max.	Unit
Operating Frequency	f_{SCP}	-	2.75	MHZ
SCP Pulse Width	T_{CWH}, T_{CWL}	150	-	ns
SCP Rise/Fall Time	t_r, t_f	-	30	ns
LP Set up Time	t_{ISU}	150	290	ns
LP Hold Time	t_{IHD}	5	40	ns
Data Set up Time	t_{DSU}	170	-	ns
Data Hold Time	t_{DHD}	80	-	ns
FR Delay Time	T_d	0	90	ns
CDATA Set up Time	T_{CSU}	450	850	ns
CDATA Hold Time	T_{CHD}	450	950	ns

AGM2464E SERIES GRAPHIC MODULE

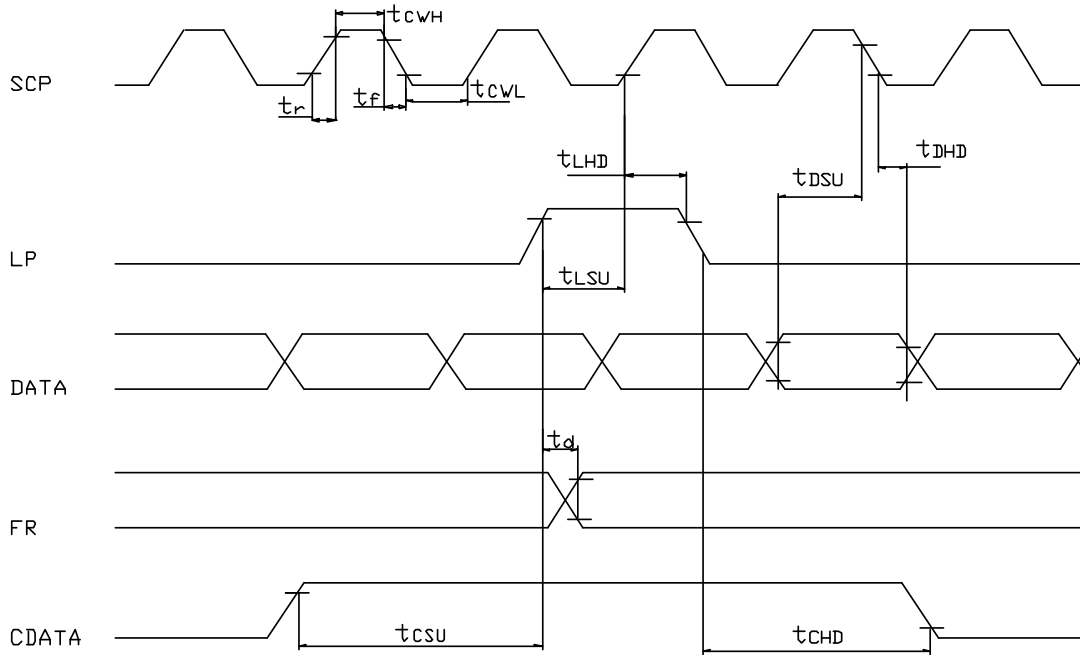

(3) External RAM Read/Write Mode ($T_A=0-50\text{deg.C}$, $V_{DD}=5V \pm 10\%$ $V_{SS}=0V$)

Item	Symbol	Min.	Max.	Unit
Address Delay Time	T_{d1}	-	250	ns
CE Fall Delay Time(Read)	T_{d2}	-	180	ns
CE Rise Delay Time(Read)	T_{d3}	-	180	ns
Data Set up Time	T_{DS}	0		ns
Data Hold Time	T_{DH}	30		ns
CE Fall Delay Time(Write)	T_{d4}	-	200	ns
CE Rise Delay Time(Write)	T_{d5}	-	200	ns
R/W Fall Delay Time	T_{d6}	-	180	ns
R/W Rise Delay Time	T_{d7}	-	180	ns
Data Stable Time	T_{d8}	-	450	
Data Hold Time	T_{d9}	-	200	ns

1. External RAM Read

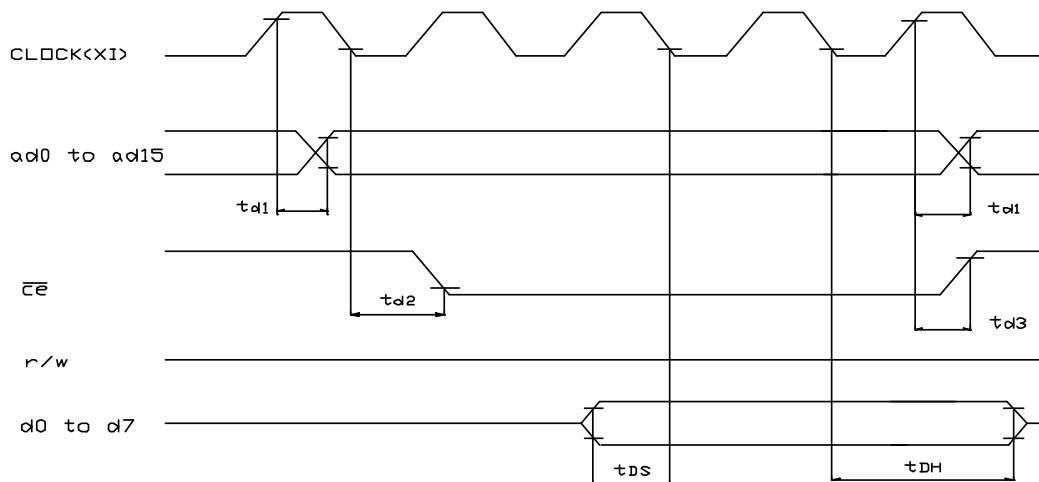

AGM2464E SERIES GRAPHIC MODULE

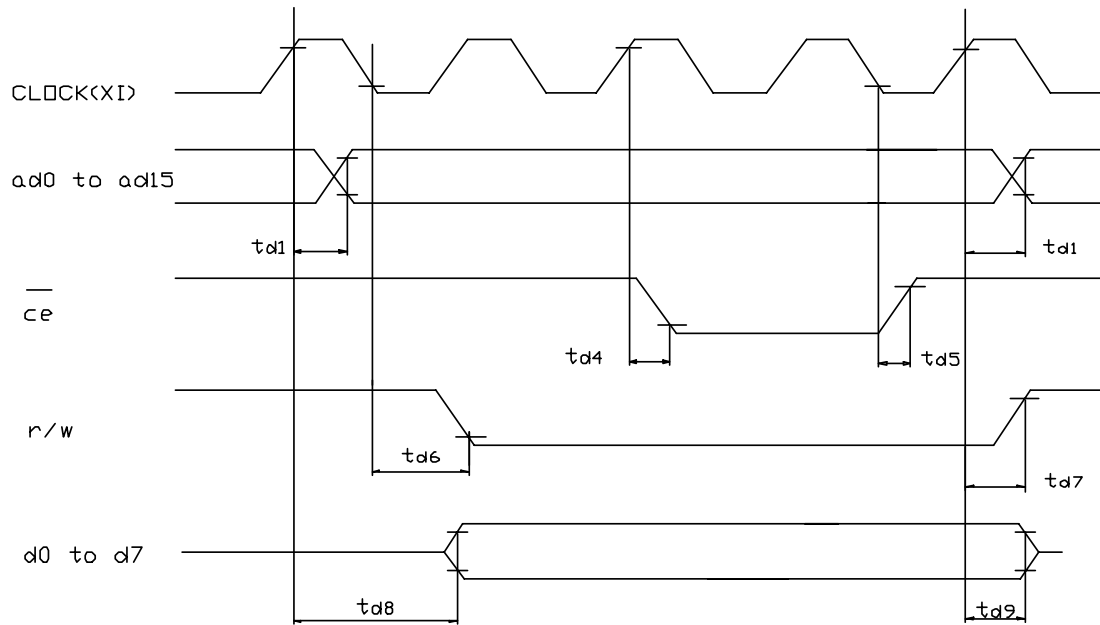

10.0 RELIABILITY TEST

Storage Condition	Content	Evaluations and Assessment*			
		Current Consumption	Oozing	Contrast	Other Appearances
Operation at high temperature and humidity	40 C, 90% RH, 240hrs	Twice initial value or less	none	More than 80% of initial value	No abnormality
High temperature storage	60 C, 240hrs	Twice initial value or less	none	More than 80% of initial value	No abnormality
Low temperature storage	-20 C, 240hrs	Twice initial value or less		More than 80% of initial value	No abnormality

*Evaluations and assessment to be made two hours after returning to room temperature (25C – 5C).

*The LCDs subjected to the test must not have dew condensation.

AGM2464E SERIES GRAPHIC MODULE

11.0 DISPLAY CONTROL INSTRUCTION

The display control instructions control the internal state of the T6963c.

COMMAND	Control State			Code								DESCRIPTION
	CD	RD	WR	D7	D6	D5	D4	D3	D2	D1	D0	
REGISTERS SETTIBG	1	1	0	0	0	1	0	0	N2	N1	N0	N2 N1 N0 0 0 1 Set Cursor Pointer 0 1 0 Set Offset Register 1 0 0 Set address Pointer
SET CONTROL WORD	1	1	0	0	1	0	0	0	0	N1	N0	N1 N0 0 0 Set Text Home Address 1 1 Set Text Area 2 0 Set Graphic Home Address 1 1 Set Graphic Area
MODE SET	1	1	0	1	0	0	0	C G	N2	N1	N0	CG=0: Internal CG ROM Mode CG=1: Internal CG ROM Mode N2 N1 N0 Graphic & Text 0 0 0 OR Mode 0 0 1 Exor Mode 0 1 1 And Mode 1 0 0 Text Attribute Mode
DISPLAY MODE	1	1	0	1	0	0	1	N3	N2	N1	N0	N3=0: Display Off N3=1: Display On N2=0: Text Off N2=1: Text On N1=0: Cursor Off N1=1: Cursor On N0=0: Blink Off N0=1: Blink On
CURSOR PATTERN SELECT	1	1	0	1	0	1	0	0	N2	N1	N0	N2,N1,N0 Line Number of Cursor N2 N1 N0 0 0 0 1-Line Cursor (Bottom Line) 1 1 1 8-Line Cursor (8x8Dots)
DATA AUTO READ/WRITE	1	1	0	1	0	1	1	0	0	N1	N0	N1 N0 0 0 Data Auto Write 0 1 Data Auto Read 1 * Auto Reset
DATA READ/WRITE	1	1	0	1	1	0	0	0	N2	N1	N0	N2=0: ADP Variable N2=1: ADP Nonvariable N1=0: Increment ADP N1 =1: Decrement ADP N0=0: Data Write N0=1: Data Read
SCREEN PEEK	1	1	0	1	1	1	0	0	0	0	0	Screen Peek
SCREEN COPY	1	1	0	1	1	1	0	1	0	0	0	Screen Copy
BIT SET/RESET	1	1	0	1	1	1	1	N3	N2	N1	N0	N3=0: Bit Reset N3=1: Bit Set N2, N1, N0 Bit Address 000-D0, 111-D7
DATA WRITE	0	1	0	Write Data							Writes data DB0~DB7 into display data RAM. After writing instruction	
DATA READ	0	0	1	Read Data							Reads data DB0~DB7 from display data RAM to the data bus.	