

ABR5000W - ABR5010W

PRV : 50 - 1000 Volts

Io : 50 Amperes

FEATURES :

- * High case dielectric strength
- * High surge current capability
- * High reliability
- * Low reverse current
- * Low forward voltage drop
- * Ideal for printed circuit board
- * **Pb / RoHS Free**

MECHANICAL DATA :

- * Case : Molded plastic with heatsink integrally mounted in the bridge encapsulation
- * Epoxy : UL94V-O rate flame retardant
- * Terminals : Plated lead solderable per MIL-STD-202, Method 208 guaranteed
- * Polarity : Polarity symbols marked on case
- * Mounting position : Bolt down on heat-sink with silicone thermal compound between bridge and mounting surface for maximum heat transfer efficiency
- * Weight : 15.95 grams

AVALANCHE BRIDGE RECTIFIERS

BR50W

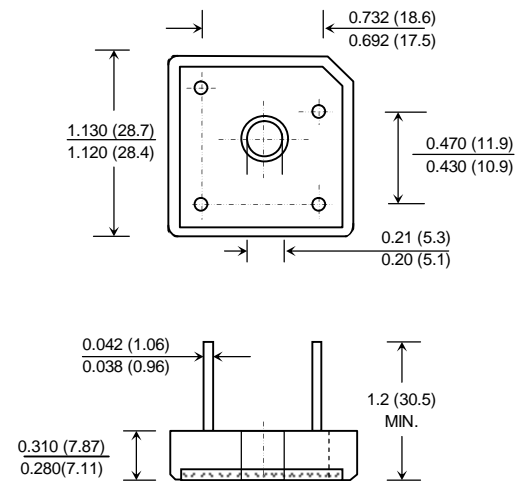

Dimensions in inches and (millimeters)

MAXIMUM RATINGS AND ELECTRICAL CHARACTERISTICS

Rating at 25 °C ambient temperature unless otherwise specified.
Single phase, half wave, 60 Hz, resistive or inductive load.
For capacitive load, derate current by 20%.

RATING	SYMBOL	ABR 5000W	ABR 5001W	ABR 5002W	ABR 5004W	ABR 5006W	ABR 5008W	ABR 5010W	UNIT
Maximum Recurrent Peak Reverse Voltage	V_{RRM}	50	100	200	400	600	800	1000	V
Maximum RMS Voltage	V_{RMS}	35	70	140	280	420	560	700	V
Maximum DC Blocking Voltage	V_{DC}	50	100	200	400	600	800	1000	V
Minimum Avalanche Breakdown Voltage at 100 μ A	$V_{BO(min)}$	100	150	250	450	700	900	1100	V
Maximum Avalanche Breakdown Voltage at 100 μ A	$V_{BO(max)}$	550	600	700	900	1150	1350	1550	V
Maximum Average Forward Current $T_c = 50^\circ\text{C}$	$I_{F(AV)}$	50							A
Peak Forward Surge Current Single half sine wave Superimposed on rated load (JEDEC Method)	I_{FSM}	400							A
Rating for fusing at ($t < 8.3$ ms.)	I^2t	660							A^2S
Maximum Forward Voltage per Diode at $I_F = 25$ A	V_F	1.1							V
Maximum DC Reverse Current $T_a = 25^\circ\text{C}$ at Rated DC Blocking Voltage $T_a = 100^\circ\text{C}$	I_R	10							μA
	$I_{R(H)}$	200							μA
Typical Thermal Resistance (Note 1)	$R_{\theta JC}$	1							$^\circ\text{C/W}$
Operating Junction Temperature Range	T_J	- 50 to + 150							$^\circ\text{C}$
Storage Temperature Range	T_{STG}	- 50 to + 150							$^\circ\text{C}$

Note : 1) Thermal resistance from junction to case with units mounted on heatsink.

RATING AND CHARACTERISTIC CURVES (ABR5000W - ABR5010W)

FIG.1 - DERATING CURVE FOR OUTPUT RECTIFIED CURRENT

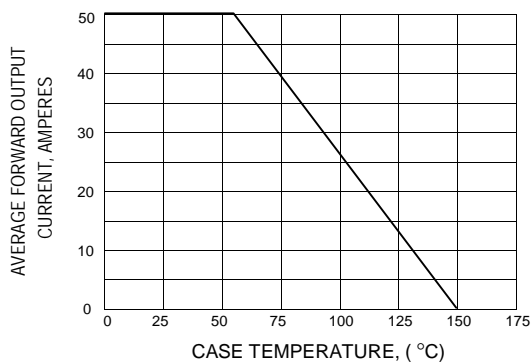

FIG.2 - MAXIMUM NON-REPETITIVE PEAK FORWARD SURGE CURRENT

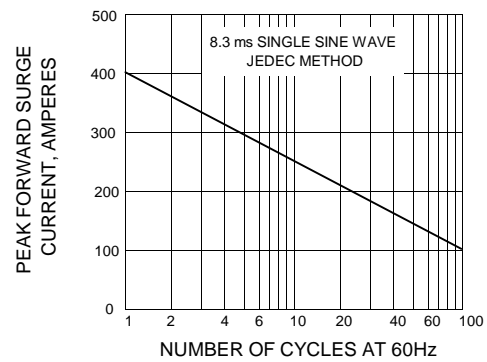

FIG.3 - TYPICAL FORWARD CHARACTERISTICS PER DIODE

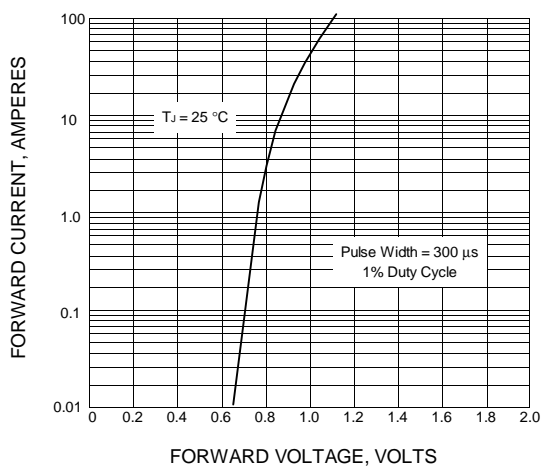

FIG.4 - TYPICAL REVERSE CHARACTERISTICS

