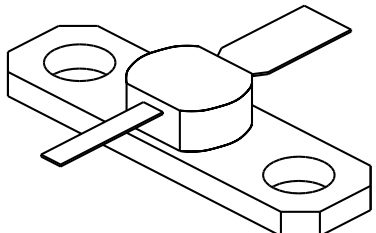

**2001**  
1.0 Watt - 28 Volts, Class C  
Microwave 2000 MHz

<p><b>GENERAL DESCRIPTION</b> The 2001 is a COMMON BASE transistor capable of providing 1 Watts Class C, RF output power at 2000 MHz. Gold Metalization and diffused ballasting are used to provide high reliability and supreme ruggedness. The transistor uses a fully hermetic High Temperature Solder Sealed package.</p>	<p><b>CASE OUTLINE</b> <b>55BT-1, Style 1</b></p> 
<p><b>ABSOLUTE MAXIMUM RATINGS</b></p> <p>Maximum Power Dissipation @ 25°C <span style="float: right;">5.0 Watts</span></p> <p><b>Maximum Voltage and Current</b></p> <p>BVces Collector to Emitter Voltage <span style="float: right;">50 Volts</span>          BVebo Emitter to Base Voltage <span style="float: right;">3.5 Volts</span>          Ic Collector Current <span style="float: right;">0.25 A</span></p> <p><b>Maximum Temperatures</b></p> <p>Storage Temperature <span style="float: right;">- 65 to + 200°C</span>          Operating Junction Temperature <span style="float: right;">+ 200°C</span></p>	

**ELECTRICAL CHARACTERISTICS @ 25 °C**

SYMBOL	CHARACTERISTICS	TEST CONDITIONS	MIN	TYP	MAX	UNITS
<b>Pout</b>	Power Out	F = 2 GHz	1.0			Watt
<b>Pin</b>	Power Input	Vcb = 28 Volts			0.125	Watt
<b>Pg</b>	Power Gain	Po = 1.0 Watts	9.0	9.5		dB
$\eta_c$	Collector Efficiency	As Above		40		%
<b>VSWR<sub>1</sub></b>	Load Mismatch Tolerance	F = 2 GHz, Po = 1.0 W			30:1	

<b>BVces</b>	Collector to Emitter Breakdown	Ic = 10 mA	50			Volts
<b>BVcbo</b>	Collector to Base Breakdown	Ic = 1 mA	45			Volts
<b>BVebo</b>	Emitter to Base Breakdown	Ie = 1.0 mA	3.5			Volts
<b>Icbo</b>	Collector to Base Current	Vcb = 28 Volts			500	µA
<b>h<sub>FE</sub></b>	Current Gain	Vce = 5 V, Ic = 100 mA	20			
<b>Cob</b>	Output Capacitance	F = 1 MHz, Vcb = 28 V		4.0		pF
$\theta_{jc}$	Thermal Resistance				35	°C/W

Issue August 1996

GHz TECHNOLOGY INC. RESERVES THE RIGHT TO MAKE CHANGES WITHOUT FURTHER NOTICE. GHz RECOMMENDS THAT BEFORE THE PRODUCT(S) DESCRIBED HEREIN ARE WRITTEN INTO SPECIFICATIONS, OR USED IN CRITICAL APPLICATIONS, THAT THE PERFORMANCE CHARACTERISTICS BE VERIFIED BY CONTACTING THE FACTORY.

**POWER OUTPUT VS FREQUENCY**

V<sub>cc</sub>=28V, P<sub>in</sub>=0.125W

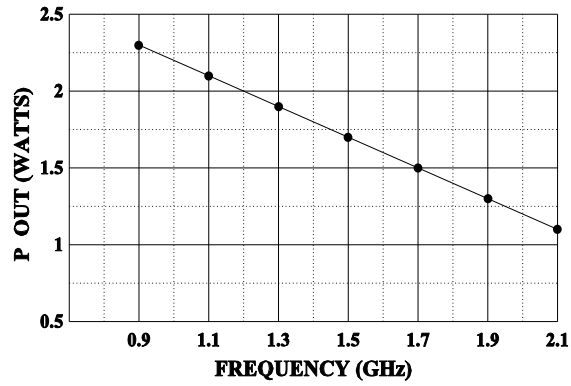

**EFFICIENCY VS FREQUENCY**

V<sub>cc</sub>=28V

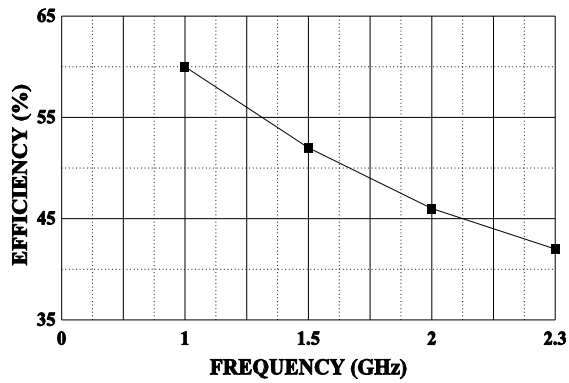

**POWER OUTPUT VS POWER INPUT**

V<sub>cc</sub>=28V

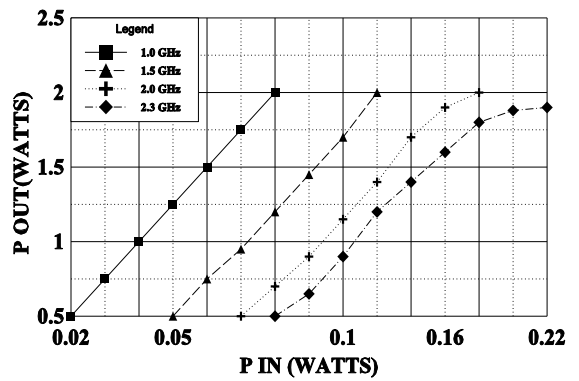

**SMITH CHART**

**2001**

**NORMALIZED IMPEDANCE AND ADMITTANCE COORDINATES**

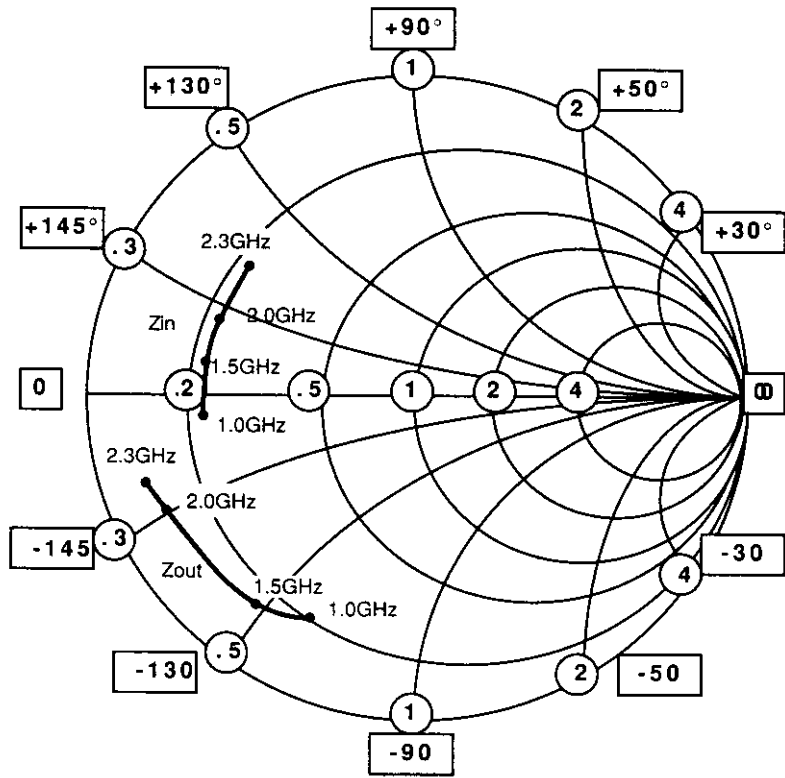

**NORMALIZED TO A 50 OHM SYSTEM.**

REVISIONS

ZONE	REV	DESCRIPTION	DATE	APPROVED
------	-----	-------------	------	----------

DIM	INCHES
A	.650
B	.300
C	.510
D	.050
E	.315
F	.420
G	.640
H	.300
I	.200
J	.330
K	.180
L	.710
M	.720
N	.300
O	.400

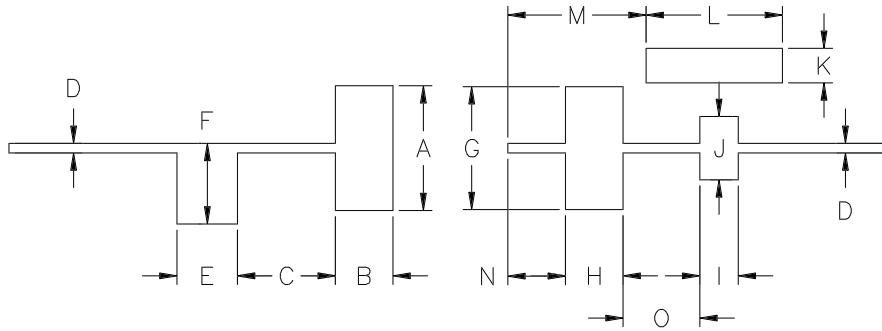

2001 TEST AMPLIFIER  
F = 2.0 GHz

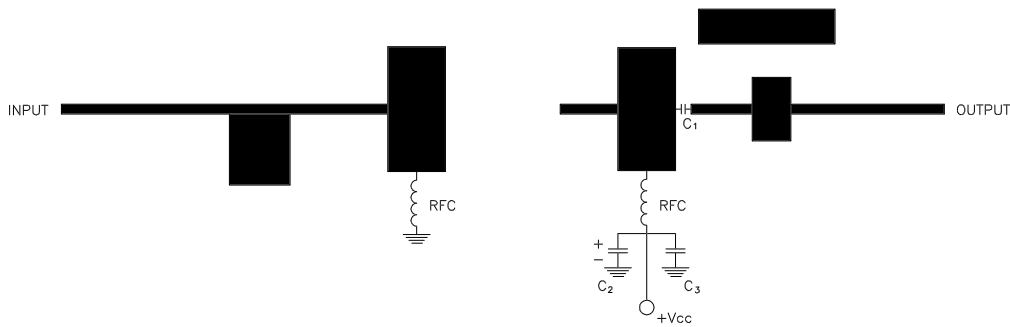

- = MICROSTRIP ON 15 MIL DUROID Er = 2.3
- C<sub>1</sub> = 3.6 ATC A CHIP
- C<sub>2</sub> = 180pf ATC B CHIP
- C<sub>3</sub> = 10 MFD 50V



CAGE OPJR2	DWG NO. 2001	REV A
SCALE 1/1	SHEET	