

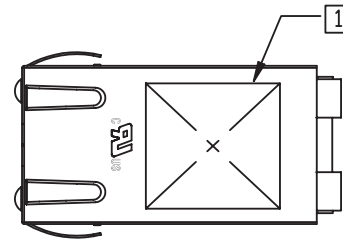

# INTEGRATED CONNECTOR MODULES

## 0826-1X1T-43-F Gigabit Ethernet MagJack® with LEDs



RECOMMENDED PCB FOOTPRINT  
COMPONENT SIDE VIEW

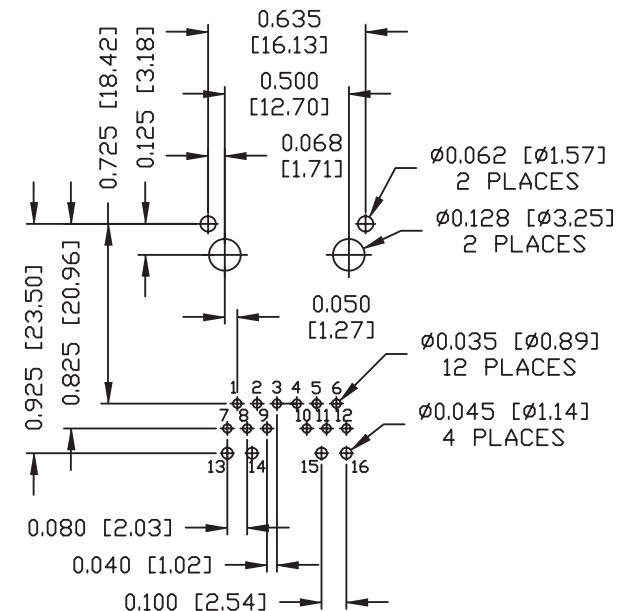
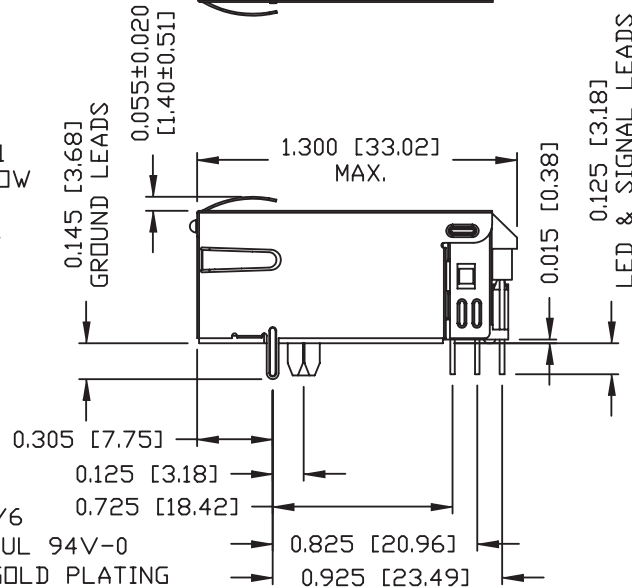
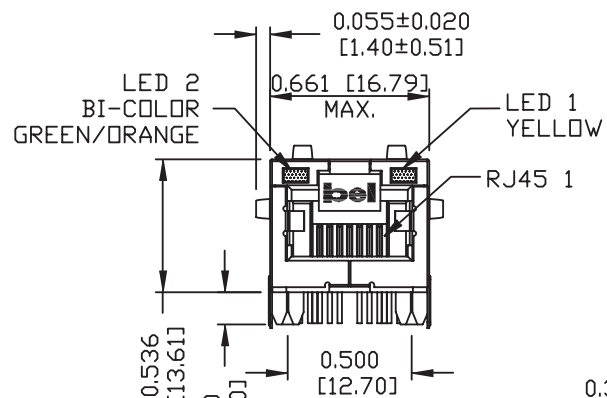

**NOTES:**

- PLASTIC HOUSING: THERMOPLASTIC PA 4/6  
FLAMMABILITY RATING UL 94V-0
  - CONTACTS PLATING: 50 MICRO-INCH HARD GOLD PLATING
  - OUTPUT PINS: TIN-COATED COPPER WIRE, DIA 0.018 INCH.
  - METAL SHIELD: NICKEL PLATED ON COPPER ALLOY.  
(ALL GROUND LEADS ARE SOLDER DIPPED)
- RoHS COMPLIANT, PER EU DIRECTIVE 2002/95/EC

1. MARK PART WITH MFG LOGO, MFG NAME, PART NUMBER, AND DATE CODE.

US UL RECOGNIZED - FILE #E196366 AND E169987.

# INTEGRATED CONNECTOR MODULES

## 0826-1X1T-43-F Gigabit Ethernet MagJack® with LEDs



SUGGESTED PANEL OPENING

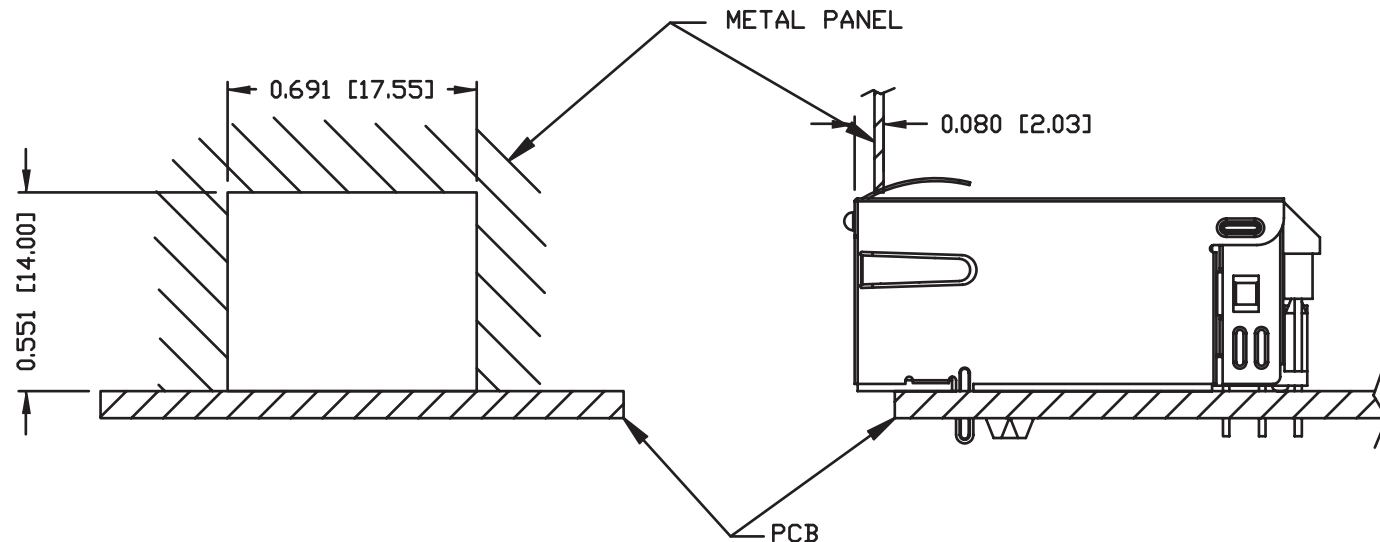

**NOTE:**

THE DISTANCE OF PANEL INSIDE SURFACE RELATIVE TO FRONT SURFACE OF PART IS ONLY A SUGGESTION. IN CASE THIS DISTANCE IS DIFFERENT, THE REQUIRED PANEL OPENING DIMENSIONS CHANGE ACCORDINGLY.

**PACKING INFORMATION**

PACKING TRAY : 0200-9999-F6 (TOP)  
0200-9999-F7 (BOTTOM)

PACKING QUANTITY : 40 PCS FINISHED GOODS PER TRAY  
10 TRAYS (400 PCS FINISHED GOODS) PER CARTON BOX

NOTE : CARDBOARDS ARE PLACED BETWEEN LAYERS OF PACKING TRAY INSIDE CARTON BOX  
(INCLUDE THE UPPERMOST AND LOWERMOST TRAY)