

INTEGRATED CONNECTOR MODULES

0816-1X1T-43 Gigabit Ethernet Single Port MagJack®

ELECTRICAL CHARACTERISTICS @ 25°C

URNS RATIO

TP1	1CT : 1CT ±2%
TP2	1CT : 1CT ±2%
TP3	1CT : 1CT ±2%
TP4	1CT : 1CT ±2%

CL @ 100kHz/100mVRMS

8mA DC BIAS 350µH MIN.

INS. LOSS

0.1MHz TO 1MHz	-1.1 dB MAX
1MHz TO 65MHz	-0.5 dB MAX
65MHz TO 100MHz	-0.8 dB MAX
100MHz TO 125MHz	-1.2 dB MAX

RET. LOSS (MIN)

0.5MHz-40MHz	-18 dB
40MHz-100MHz	-12+20LOG(f/80MHz) dB

CM TO CM REJ

100kHz - 100MHz -30 dB MIN

CM TO DM REJ

100kHz - 100MHz -35 dB MIN

HIPOT (Isolation Voltage):

1500 Vrms

SCHEMATIC

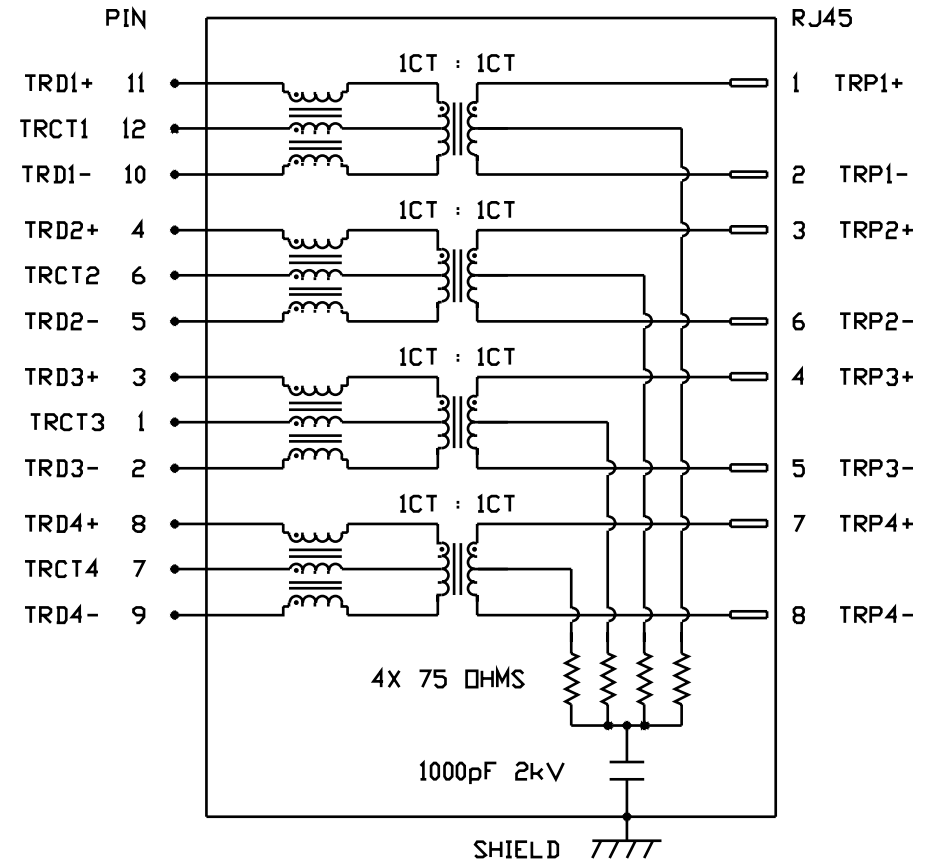

INTEGRATED CONNECTOR MODULES

0816-1X1T-43 Gigabit Ethernet Single Port MagJack®

MECHANICAL SPECIFICATION

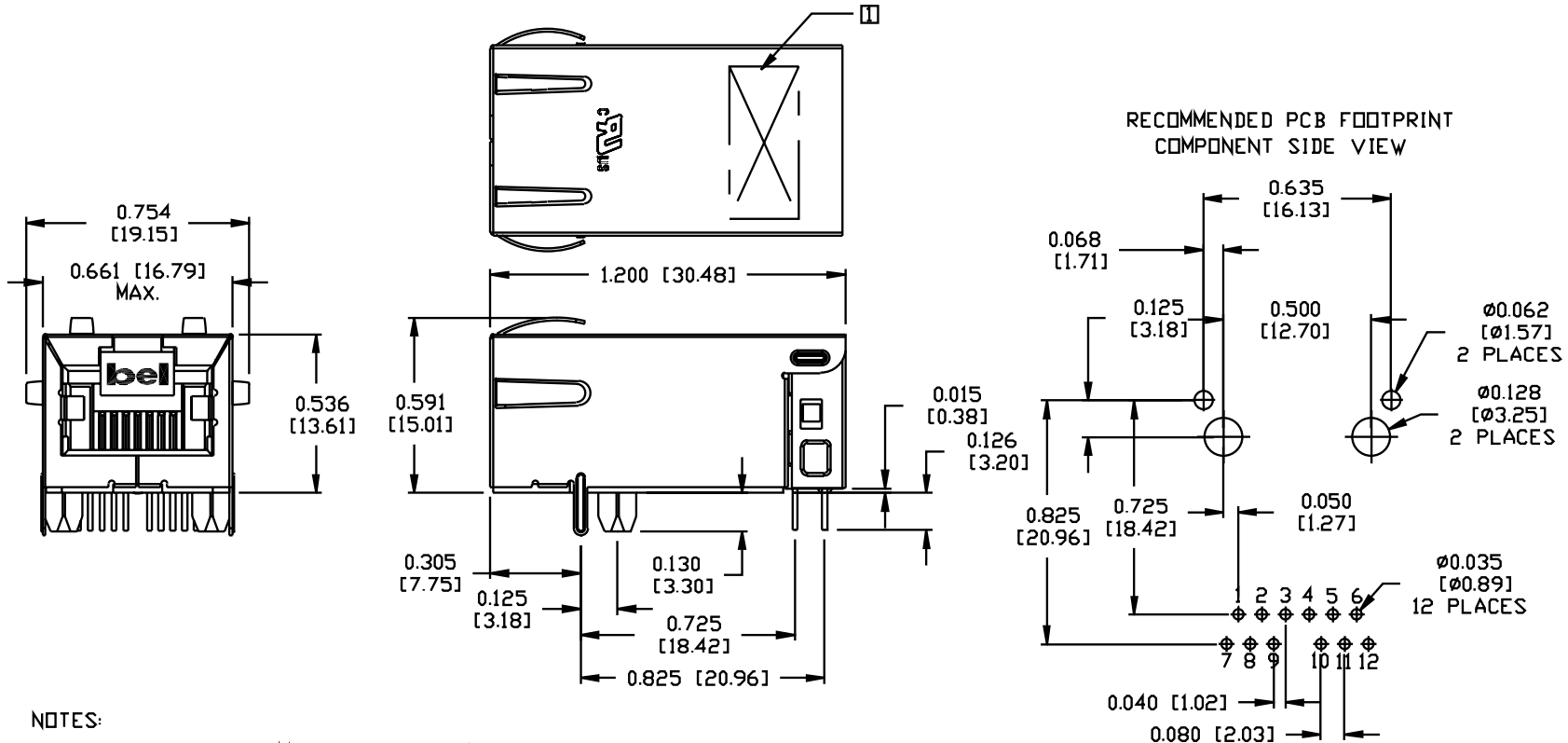

NOTES:

- PLASTIC HOUSING: THERMOPLASTIC PA 4/6
- FLAMMABILITY RATING UL 94V-0
- CONTACTS: 50 MICRO-INCH HARD GOLD PLATING
- OUTPUT PINS: TIN-COATED COPPER WIRE, DIA 0.018 INCH.
- SOLDERABILITY: PER MIL STD. 202, METHOD 208.
- METAL SHIELD: TIN/LEAD PLATED ON COPPER ALLOY.
- ☐ MARK PART WITH MFG LOGO, MFG NAME, PART NUMBER, AND DATE CODE.
- UL RECOGNIZED - FILE #E196366 AND E169987.

INTEGRATED CONNECTOR MODULES

0816-1X1T-43 Gigabit Ethernet Single Port MagJack®

SUGGESTED PANEL OPENING

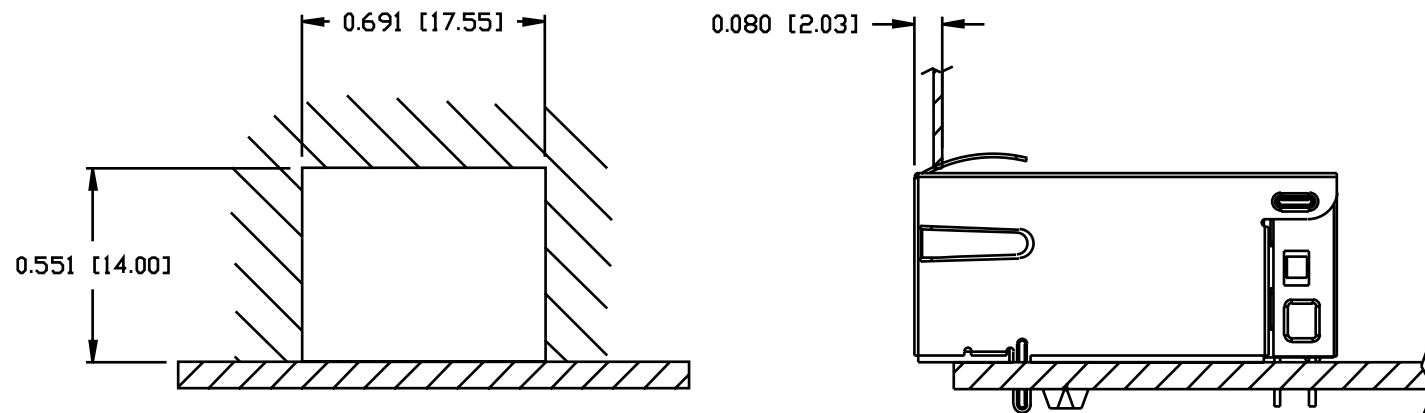

PACKING INFORMATION

PACKING TRAY : 0200-9999-F1 (TOP)

0200-9999-F2 (BOTTOM)

PACKING QUANTITY : 40 PCS FINISHED GOODS PER TRAY

10 TRAY (400 PCS FINISHED GOODS) PER CARTON BOX

NOTE : CARDBOARDS ARE PLACED BETWEEN LAYERS OF PACKING TRAY INSIDE CARTON BOX
(INCLUDE THE UPPERMOST AND LOWERMOST TRAY)