

ZXLD1350EV3 - circuit diagram and bill of materials

Circuit diagram

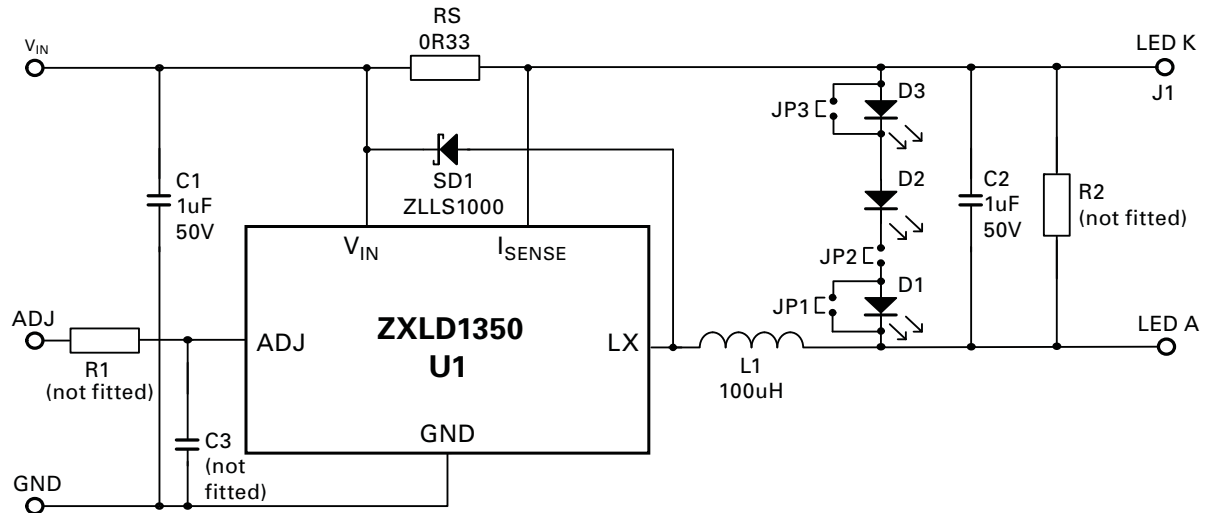

Bill of materials

Qty.	Part ref.	Value	Description	Source
1	N/A	ZDB345R1	PCB	Zetex design
1	RS	0.33R	Resistor, 0805, +/-1% +/-250ppm NCST10FR330FTRF NIC Components, Welwyn LR1206-R033FI, Panasonic ERJ-6RQFR33V	NIC Components, TT Electronics (Welwyn) (Farnell 774-6091), Digi-Key
1	C1	1µF	Capacitor 50v 1206 X7R TDK C3216X7R1H105K	Mouser
2	C2, C3		Not fitted	
1	U1	ZXLD1350	LED buck driver	Zetex
1	L1	100µH	MSS6132 100µH Coilcraft, NPIS53D101MTRF NIC components	Coilcraft, NIC Components
1	SD1	ZLLS1000	Schottky diode, Zetex	Zetex
3	D1,D2,D3	XR-E7090	Cree Power LED	Cree
1	R1		Not fitted	
3	JP1,JP2,JP3		Jumper pin strip	Farnell 412-9428 (36 way)
3	N/A		JP1, JP2, JP3 jumpers. JP1, JP3 to be fitted 'open', i.e. on one pin only. JP2 to be fitted 'shorted', i.e. on both pins.	Rapid 22-0690
5	+V _{IN} ,GND,ADJ, LEDk,LEDa		1.3mm test loop	Rapid 17-1820
1	N/A		Loctite 315 'OUTPUT' thermal adhesive for attaching LEDs	Farnell 537-020