

FEATURES

- **HIGH OUTPUT POWER:** 25.0 dBm TYP @ P₁ dB
- **HIGH LINEAR GAIN:** 9.0 dB TYP @ 14.5 GHz
- **HIGH EFFICIENCY:** 35% TYP @ 14.5 GHz
- **HIGH RELIABILITY**
- **CLASS A OPERATION**

OUTLINE DIMENSIONS (Units in mm)

PACKAGE OUTLINE 75

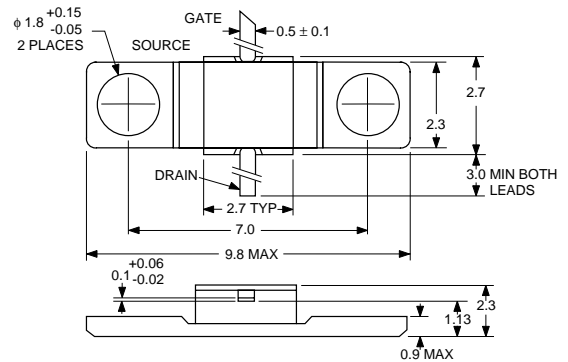

DESCRIPTION

The NE960R275 is a Power GaAs MESFET covering the 4 GHz to 18 GHz range and is designed for X and Ku Band amplifiers and oscillator applications.

The device incorporates WSi (tungsten silicide) gate and silicon dioxide glassivation. NEC's stringent quality assurance and test procedures assure the highest reliability and performance.

ELECTRICAL CHARACTERISTICS (T_A = 25°C)

PART NUMBER				NE960R275				
PACKAGE OUTLINE				75				
	SYMBOLS	CHARACTERISTICS	UNITS	MIN	TYP	MAX	TEST CONDITIONS	
Functional Characteristics	GL	Linear Gain	dB	8.0	10.0		V _{DS} = 9 V I _{DSQ} = 90 mA f = 14.5 GHz, R _g = 1KΩ	
	P _{1dB}	Output Power (1 dB)	dBm		25.0			
	P _{OUT}	Power Out at Fixed Input Power	dBm	22.0	24.0			P _{IN} = 15 dBm ¹
	η _{ADD}	Power Added Efficiency	%		35			P _{OUT} = P _{1dB} ¹
Electrical Characteristics	R _{TH}	Thermal Resistance	°C/W			60	Channel to Case	
	I _{DSS}	Saturated Drain Current	A	0.09	0.2	0.35	V _{DS} = 1.5 V, V _{GS} = 0 V	
	V _p	Pinch-off Voltage	V	-2.5	-1.8	-0.5	V _{DS} = 2.5 V, I _{DS} = 1 mA	
	BV _{GD}	Gate to Drain Break Down Voltage	V	15			I _{GD} = 1 mA	

Note:

1. V_{DS} = 9 V, I_{DSQ} = 90 mA, f = 14.5 GHz.

ABSOLUTE MAXIMUM RATINGS¹ (T_A = 25 °C)

SYMBOLS	PARAMETERS	UNITS	RATINGS
V _{DS}	Drain to Source Voltage	V	15
V _{GS}	Gate to Source Voltage	V	-7
P _t	Total Power Dissipation	W	2.5
I _D	Drain Current	mA	350
I _{GF}	Gate Current (forward)	mA	2.5
I _{GR}	Gate Current (reverse)	mA	-2.5
T _{CH}	Channel Temperature	°C	175
T _{STG}	Storage Temperature	°C	-65 to +175

Note:

1. Operation in excess of any one of these parameters may result in permanent damage.

RECOMMENDED OPERATING LIMITS

SYMBOLS	PARAMETERS	UNITS	MIN	TYP	MAX
V _{DS}	Drain to Source Voltage	V		9	9
T _{CH}	Channel Temperature	°C			130
G _{COMP}	Gain Compression	dB _{comp}			3

TYPICAL PERFORMANCE CURVES (T_A = 25°C)

OUTPUT POWER AND EFFICIENCY vs. INPUT POWER

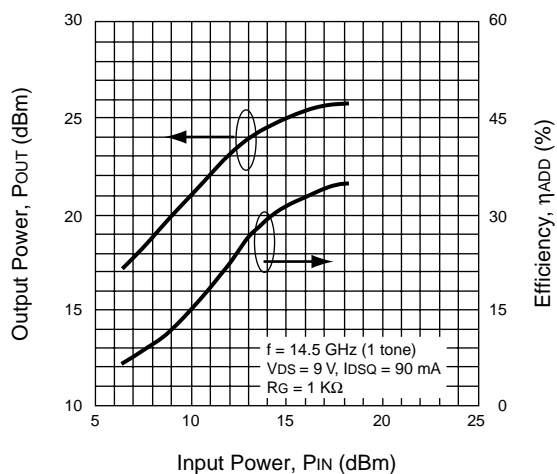

DRAIN CURRENT AND LINEAR GAIN vs. INPUT POWER

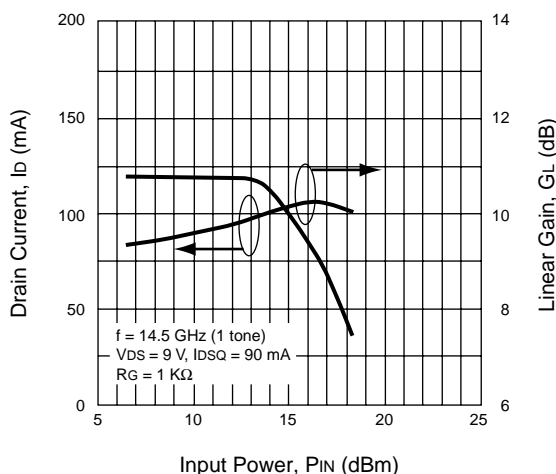

GATE CURRENT vs. INPUT POWER

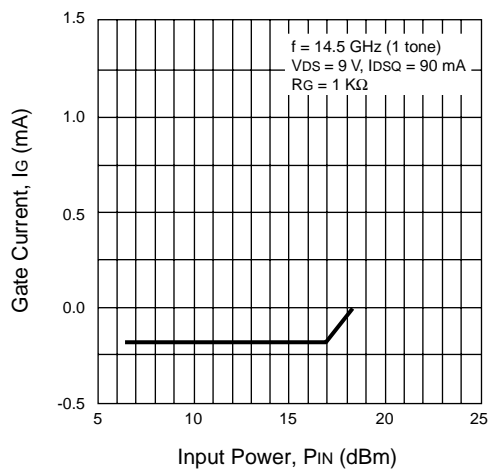

TYPICAL SCATTERING PARAMETERS (TA = 25°C)

NE960R275

Vds = 9.0 V, Idsq = 90 mA

FREQUENCY	S11		S21		S12		S22	
	MAG	ANG	MAG	ANG	MAG	ANG	MAG	ANG
2.0	0.89	-113	3.99	98	0.057	34	0.42	-79
3.0	0.86	-129	2.88	80	0.058	15	0.46	-85
4.0	0.85	-138	2.29	65	0.057	10	0.43	-94
5.0	0.84	-140	1.99	51	0.057	7	0.41	-110
6.0	0.81	-144	1.78	39	0.059	5	0.44	-125
7.0	0.83	-152	1.77	27	0.060	3	0.49	-135
8.0	0.81	-163	1.82	15	0.062	3	0.53	-141
9.0	0.75	-176	1.89	0	0.062	1	0.52	-150
10.0	0.71	166	2.12	-19	0.064	0	0.47	-167
11.0	0.62	140	2.42	-44	0.072	-17	0.45	164
12.0	0.48	86	2.50	-78	0.074	-46	0.50	129
13.0	0.54	20	2.32	-113	0.065	-88	0.56	94
14.0	0.69	-20	1.77	-144	0.049	-132	0.57	68
15.0	0.80	-45	1.30	-166	0.040	-176	0.61	44
16.0	0.81	-66	1.03	167	0.039	149	0.67	27

START 2 GHz, STOP 16 GHz, STEP 1 GHz

