



# Obsolescence Notice

This product is obsolete.

This information is available for your convenience only.

For more information on Zarlink's obsolete products and replacement product lists, please visit

[http://products.zarlink.com/obsolete\\_products/](http://products.zarlink.com/obsolete_products/)

The VP211 is a dual 90MHz 6-bit Analog to Digital Converter designed for use in consumer satellite receivers and decoders, video systems, multimedia and communications applications.

Operating from a single +5V supply, the VP211 includes an on-chip high bandwidth ADC driver amplifier, a 6-bit ADC and digital I/O that can be interfaced to either +5V or +3V. The VP211 also has the necessary bias voltages for the reference resistor chain in the 'flash' architecture of the ADC.

### FEATURES

- 90MHz Conversion Rate
- TTL Clock/Data Interface
- 2 Volt Analog Input Range
- Internal ADC Reference
- Digital I/O's compatible with +5V or +3V logic
- Single 5 Volt Supply
- Dual ADC System for good channel matching

### APPLICATIONS

- Satellite Decoders
- Multimedia
- Communications

### ORDERING INFORMATION

VP211A CG MP1S (Commercial - 28 pin plastic SO)

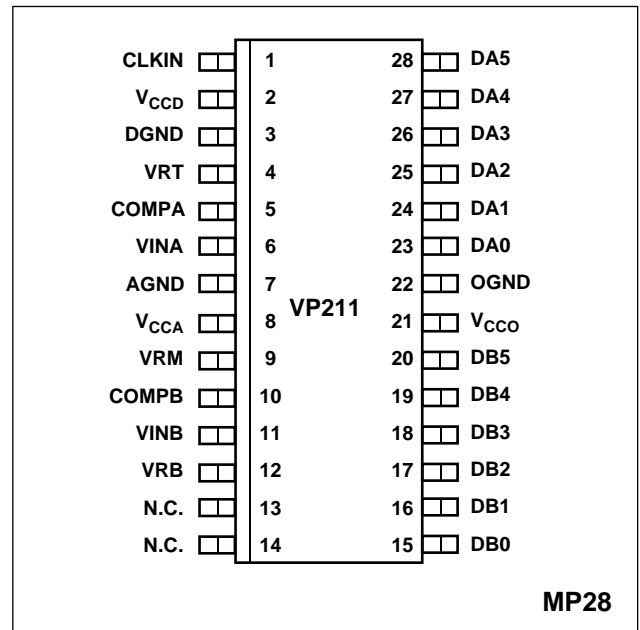

Fig.1 Pin connections - top view (wide body)

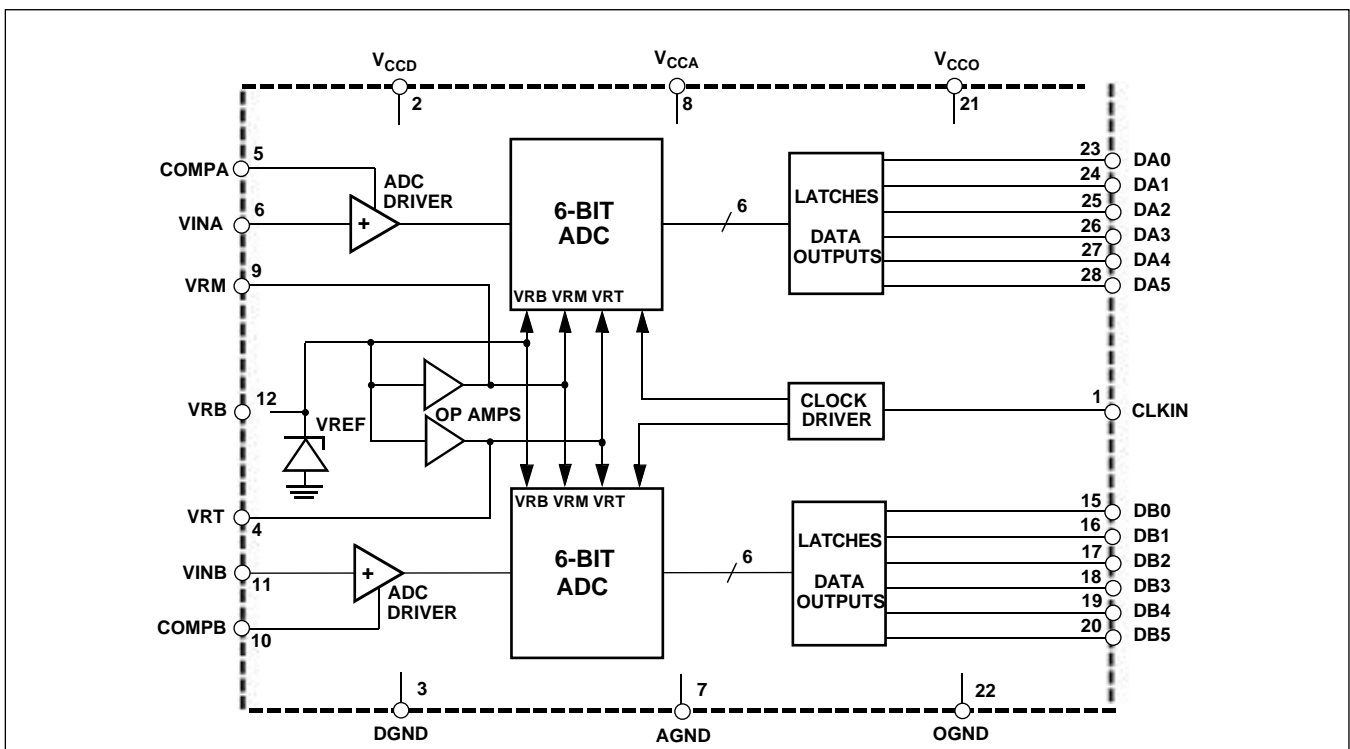

Fig.2 System block diagram

# VP211

## ABSOLUTE MAXIMUM RATINGS

DC supply voltage ( $V_{CCA}$ , $V_{CCD}$ , $V_{CCO}$ )	-0.3 to +7V
Analog input voltage ( $V_{IN}$ )	-0.3 to $V_{CC}+0.3V$
Digital inputs (CLKIN)	$V_{CC}$
Digital output current ( $I_{oh}$ , $I_{ol}$ , $I_{sc}$ )	-20 to +20mA
Ambient operating temperature ( $T_{amb}$ )	0°C to +70°C
Storage temperature ( $T_{storage}$ )	-55°C to +125°C

## THERMAL CHARACTERISTICS

### THERMAL RESISTANCES

Junction to case ( $\theta_{jc}$ )	32°C/W
Junction to ambient ( $\theta_{ja}$ )	84°C/W

## ELECTRICAL CHARACTERISTICS

Test conditions (unless otherwise stated)  $T_{amb} = 25^\circ\text{C}$ ,  $V_{CCA/D/O} = +5V$ , full temperature range = 0°C to +70°C

DC CHARACTERISTICS All specifications apply to either of the two ADCs

Characteristic	Symbol	Temp.	Test Level	Value			Units	Conditions
				Min.	Typ.	Max.		
<b>Resolution</b>	-	-	-	6	-	-	Bits	
<b>Static performance</b>								
Differential non-linearity	DNL	+25°C	4	-	-	±0.5	LSB	
		Full	4	-	-	±0.5	LSB	
Integral non-linearity	INL	+25°C	4	-	-	±0.5	LSB	
		Full	4	-	-	±0.5	LSB	
No missing codes		Full	4	Guaranteed				
<b>Power supply</b>								
Analog supply voltage	$V_{CCA}$	Full	4	4.75	5.0	5.25	V	
Digital supply voltage	$V_{CCD}$	Full	4	4.75	5.0	5.25	V	
Output supply voltage	$V_{CCO}$	Full	4	4.75	5.0	5.25	V	
Analog supply current	$A_{ICC}$	+25°C	1	14	19	26	mA	
		Full	4	-	-	-	mA	
Digital supply current	$D_{ICC}$	+25°C	1	34	42	51	mA	
		Full	4	-	-	-	mA	
Output supply current	$O_{ICC}$	+25°C	1	3	11	15	mA	
		Full	4	-	-	-	mA	
Power dissipation	PD	+25°C	1	260	360	460	mW	
<b>Analog input</b>								
Input range	$V_{in}$	Full	5	-	2.0	-	V	Pk to Pk
Input resistance	$R_{in}$	+25°C	1	20k	25k	30k		
Input capacitance	$C_{in}$	+25°C	5	-	4.0	-	pF	
Gain variation	$G_V$	+25°C	4	-	-	0.25	dB	$F_{in}=300\text{Hz}$ to 20MHz
Gain matching	$G_m$	+25°C	1	-	-	0.25	dB	$F_{in}=15.68\text{MHz}$
Input -3dB bandwidth	F3dB	+25°C	5	-	200	-	MHz	
Ain input voltage	$A_{indc}$	+25°C	1	3.6	3.9	4.1	V	
Comp output	$V_{comp}$	+25°C	1	1.8	2.0	2.2	V	
<b>CLKIN</b>								
Input voltage high	$V_{ih}$	+25°C	1	2.0	-	-	V	
		Full	4	-	-	-	V	
Input voltage low	$V_{il}$	+25°C	1	-	-	0.8	V	
		Full	4	-	-	-	V	
Input current high	$I_{ih}$	+25°C	1	-	-	1	µA	$V_{CCD} = 5.25V$
		Full	4	-	-	-		$V_{in} = 2.7V$
Input current low	$I_{il}$	+25°C	1	-0.2	-0.35	-0.5	mA	$V_{CCD} = 5.25V$
		Full	4	-	-	-		$V_{in} = 0.4V$
<b>TTL digital outputs</b>								
Output voltage high	$V_{oh}$	+25°C	1	2.4	-	3.0	V	$V_{CCO} = 4.75V$
		Full	4	-	-	-	V	$I_{oh} = 400\mu A$
Output voltage low	$V_{ol}$	+25°C	1	-	-	0.4	V	$V_{CCO} = 4.75V$
		Full	4	-	-	-	V	$I_{ol} = 1mA$
Output current high	$I_{oh}$	+25°C	1	-	-	-400	µA	$V_{CCO} = 4.75V$
		Full	4	-	-	-	-	
Output current low	$I_{ol}$	+25°C	1	-	-	1	mA	$V_{CCO} = 4.75V$
		Full	4	-	-	-	-	

## DC CHARACTERISTICS (cont.)

Characteristic	Symbol	Temp.	Test Level	Value			Units	Conditions
				Min.	Typ.	Max.		
<b>Reference voltage</b>								
V <sub>ref</sub> ladder bottom	VRB	+25°C	1	2.367	2.5	2.671	V	
V <sub>ref</sub> ladder middle	VRM	+25°C	1	2.848	3.0	3.212	V	
V <sub>ref</sub> ladder top	VRT	+25°C	1	3.337	3.5	3.763	V	

## AC CHARACTERISTICS

Characteristic	Symbol	Temp.	Test Level	Value			Units	Conditions
				Min.	Typ.	Max.		
<b>Switching performance</b>								
Clock high pulse width	T <sub>pw1</sub>	+25°C	4	5.7	-	-	ns	Load=10pF Load=10pF
Clock low pulse width	T <sub>pw0</sub>	+25°C	4	5.7	-	-	ns	
Max. conversion rate	F <sub>max</sub>	+25°C	1	90	-	-	MHz	
Data output setup time	T <sub>setup</sub>	+25°C	4	4	6	8	ns	
Data output hold time	T <sub>hold</sub>	+25°C	4	3	6	8	ns	
Aperture delay	T <sub>ad</sub>	+25°C	4	2	3	4	ns	
Aperture delay matching	T <sub>ad</sub>	+25°C	4	-	0.25	0.5	ns	
Aperture jitter	T <sub>aj</sub>	+25°C	4	10	25	50	ps rms	
<b>Dynamic performance</b>								
Differential non-linearity	DNL	+25°C	4	-0.95	-	+1.2	LSB	F <sub>CLK</sub> = 90.11MHz  F <sub>IN</sub> = 11.26MHz
Integral non-linearity	INL	+25°C	4	-	-	±1	LSB	
Signal to noise ratio	SNR	+25°C	1	31.8	-	-	dB	
Total harmonic distortion	THD	+25°C	4	40	-	-	dBc	
Effective No. of bits	ENOB	+25°C	1	5.0	5.6	-	bits	
Crosstalk rejection	CTR	+25°C	5	-	50	-	dBc	
Input offset	V <sub>os</sub>	+25°C	1	-	±0.5	±1	LSB	
Error rate	BER	+25°C	5	-	10e <sup>-8</sup>	-		

## NOTES

1. An input voltage of 0.0 volts ±0.5 LSB should nominally correspond to the '011111' to '100000'B transition edge.

## TEST LEVELS

**Level 1** - 100% production tested.

**Level 2** - 100% production tested at 25°C and sample tested at specified temperatures.

**Level 3** - Sample tested only.

**Level 4** - Parameter is guaranteed by design and characterisation testing.

**Level 5** - Parameter is typical value only.

Code	Input Voltage	Digital Output
	2.0 Volt Full Scale	Binary
00	Least positive valid input	000000
01	-	000001
●	●	●
31	-	011111
32	0	100000
33	-	100001
●	●	●
62	-	111110
63	Most positive valid input	111111

Table 1: Output coding

# VP211

## PIN DESCRIPTIONS - 28 Pin Plastic SO Package

Pin	Name	Description
1	CLKIN	TTL clock input
2	V <sub>CCD</sub>	Digital voltage supply for ADC's and input clock
3	DGND	Digital ground
4	VRT	Reference voltage- ladder top
5	COMPA	Capacitor compensation - A channel
6	VINA	Analog signal input - A channel
7	AGND	Analog ground
8	V <sub>CCA</sub>	Analog voltage supply for drivers and references
9	VRM	Reference voltage- ladder middle
10	COMPB	Capacitor compensation - B channel
11	VINB	Analog signal input - B channel
12	VRB	Reference voltage- ladder bottom
13	N.C.	Not connected
14	N.C.	Not connected
15	DB0	TTL digital output - channel B - LSB
16	DB1	
17	DB2	
18	DB3	
19	DB4	
20	DB5	TTL digital output - channel B - MSB
21	V <sub>CCO</sub>	Output voltage supply for TTL data outputs
22	OGND	Output ground
23	DA0	TTL digital output - channel A - LSB
24	DA1	
25	DA2	
26	DA3	
27	DA4	
28	DA5	TTL digital output - channel A - MSB

Table 2: Pin descriptions

## ELECTRICAL CHARACTERISTICS DEFINITIONS

### Analog Bandwidth

The analog input frequency at which the spectral power of the fundamental frequency, as determined by FFT analysis is reduced by 3dB.

### Aperture Delay

The delay between the rising edge of the 90MHz clock signal and the instant the analog input signal is sampled.

### Aperture Jitter

The sample to sample variation in aperture delay.

### Bit Error Rate (BER)

The number of spurious code errors produced for any given input sinewave frequency at a given clock frequency. In this case it is the number of codes occurring outside the histogram cusp for a 1/2 FS sinewave.

### Data Outputs, Set-up and Hold Time

Data output timings are measured from the 50% threshold to the 50% threshold on the rising edge of the output clock.

### Differential Non-linearity

The deviation in any code width from an ideal 1 LSB step.

### Effective Number of Bits (ENOB)

This is a measure of a device's dynamic performance and may be obtained from the SNR or from a sine wave curve test fit according to the following expressions:

$$\text{ENOB} = \text{SNR} - 1.76/6.02 \quad \text{or}$$

$$\text{ENOB} = N - \log_2[\text{rms error (actual)}/\text{rms error (ideal)}]$$

where N is the conversion resolution and the actual rms error is the deviation from an ideal sine wave, calculated from the converter outputs with a sine wave input.

### Integral Non-linearity (INL)

The deviation of the centre of each code from a reference line which has been determined by a least squares curve fit.

### Signal-to-Noise Ratio (SNR)

The ratio of the rms signal amplitude to the rms value of 'noise' which is defined as the sum of all other spectral components, including the harmonics, but excluding D.C. with a full-scale analog input signal.

**Device Description**

The VP211 is a dual 90MHz 6-bit ADC system, (see Fig.2). Included on chip is a high bandwidth ADC driver amplifier, a 6-bit analog to digital converter, latches and TTL compatible data outputs. The VP211 also has the necessary bias voltages for the reference resistor chain in the 'flash' architecture of the ADC.

**Analog Input**

The analog inputs, (VIN\_A,B) are A.C. coupled into the non-inverting input of the ADC driver amplifiers, which provide the necessary bandwidth, gain, offset and low impedance required to drive the ADC. The amplifier has been designed so that an input of 0 volts will produce an output level equal to the voltage present at the middle of the ADC resistor chain, VRM (3.00V typ.). This is achieved by an internal feedback loop within each amplifier which compares the amplifier output with VRM, (see Fig.3). This voltage will produce a transition binary code of 011111 to 100000 at the output of the ADC.

**Reference Voltage**

An on chip band gap voltage reference circuit combined with two op-amps provides all the necessary bias voltages for the ADC reference resistor chain, bottom (VRB), middle (VRM) and top(VRT). VRB, VRM and VRT have been brought out to pins 12, 9 and 4 respectively and should be decoupled with 100nF capacitors close to the package pins.

**ADC Circuit**

The VP211 employs a 'flash' architecture consisting of a reference resistor chain, an array of 64 comparators, encoding logic and a 6-bit latch. The 63 reference levels generated by the resistor chain are compared with the analog output signal from the ADC driver amplifier using the comparator array. This produces a thermometer code which the encoding logic converts into a 6-bit word.

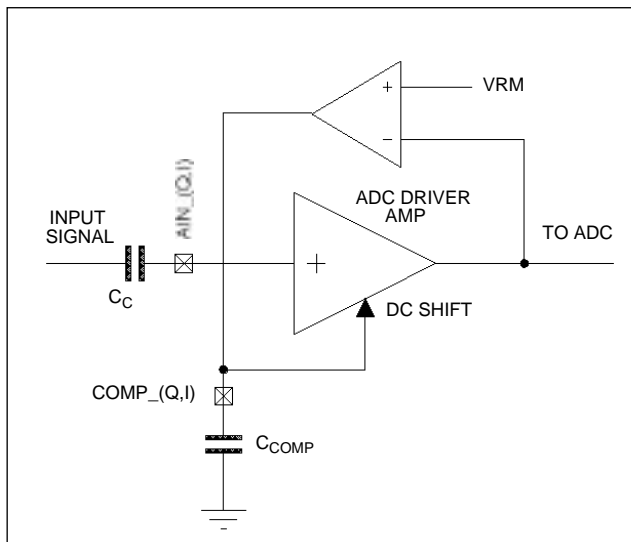

Fig.3 DC offset internal feedback loop

**Digital Interface**

The TTL data output pins, (DA0-DA5) and (DB0-DB5), have been optimized to interface with devices in close proximity to the VP211 and are designed to provide satisfactory logic levels at speeds up to 90MHz into a fanout of one and a total load capacitance of 10pF. All data outputs should have approximately equivalent loading to ensure proper setup and hold times. For capacitive loads in excess of 10pF, output buffers are recommended.

**Clock Interface**

The clock signal to the ADC synchronizes the sampling, conversion and output stages of the device as shown in the timing diagram (see Fig.4). The output of the ADC driver amp is sampled when the comparator array is latched on the rising edge of the input clock. Data is then presented to the TTL data outputs and latched on the falling edge of the input clock.

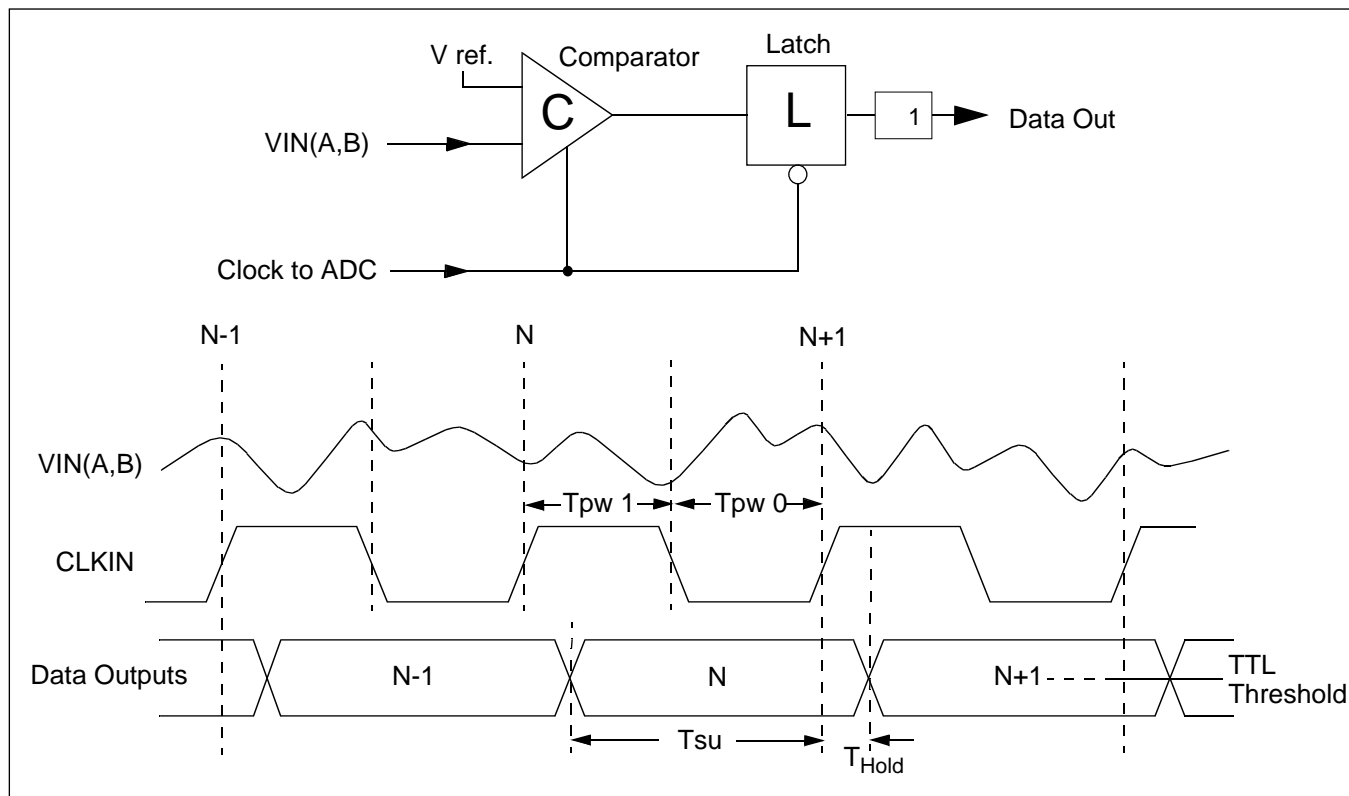

Fig.4 System timing diagram

# VP211

## Layout And Grounding

As with all high speed A to D converters, careful consideration must be given to the PCB layout. High performance can be obtained from the VP211 by tying all grounds to a solid low impedance ground plane. Separate analog and digital ground planes with a single common link under the device can also be used to help reduce the amount of digital noise fed back into the analog section of the converter.

The VP211 should be decoupled with low impedance 100nF ceramic capacitors close to the package pins to avoid lead inductance effects and the decoupling on supply lines

should further be improved by using a 47µF tantalum capacitor in parallel with a 100nF ceramic capacitor. If VCCA is derived from VCCD, a small inductor should be used to reduce digital noise on the analog power supply. Jitter and noise on clock input pins must be minimised. Long clock lines should therefore be avoided and all clock lines correctly terminated. Cross talk of digital signals to the analog inputs must also be prevented as sampling cross talk produces DC offsets on the sampled data, for this reason analog inputs should not be run next to clock or data lines. Device connections to the ground plane should be as short as possible.

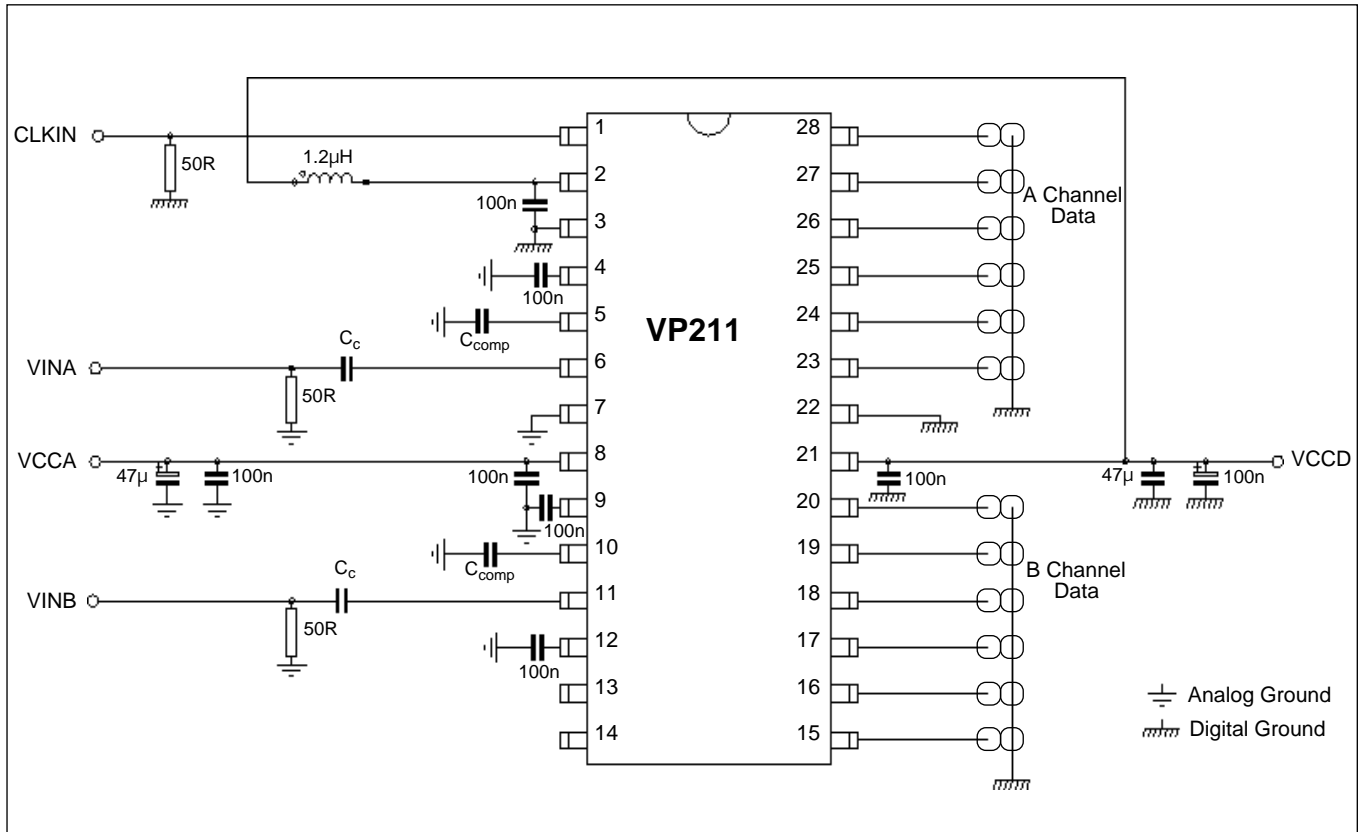

Fig.5 Applications diagram

## Application Circuit

Fig.5 shows a typical applications circuit for the VP211. The supply connections are made using separate low noise digital and analog power supplies and VCCD is further isolated from VCCO using a 1.2µH inductor.

The COMPA and COMPB pins must be decoupled to reduce any ripple at low frequencies which may distort the ADC driver amplifier output, (see Fig.2.) The decoupling capacitor value is determined by the required low frequency performance of the system and can be obtained from the following equation.

$$C_{Comp} = \frac{75 \times 10^{-6}}{F_{in} \times V_{Ripple}}$$

A ripple voltage 10mV is recommended for good system performance, e.g. If the analog input frequency  $F_{in} = 10\text{KHz}$  a value of  $0.75\mu\text{F}$  is required for  $C_{Comp}$ .

To ensure effective A.C. coupling at low input frequencies, the coupling capacitors on pins 6 and 11 can be calculated from the high pass filter corner frequency equation,

$$F_c = \frac{1}{2 \times R \times C}$$

where

$F_c$  = Lower -3dB corner frequency  
 (R = Input Resistance, 25K typ. - 20K min)



**For more information about all Zarlink products  
visit our Web Site at  
[www.zarlink.com](http://www.zarlink.com)**

Information relating to products and services furnished herein by Zarlink Semiconductor Inc. or its subsidiaries (collectively "Zarlink") is believed to be reliable. However, Zarlink assumes no liability for errors that may appear in this publication, or for liability otherwise arising from the application or use of any such information, product or service or for any infringement of patents or other intellectual property rights owned by third parties which may result from such application or use. Neither the supply of such information or purchase of product or service conveys any license, either express or implied, under patents or other intellectual property rights owned by Zarlink or licensed from third parties by Zarlink, whatsoever. Purchasers of products are also hereby notified that the use of product in certain ways or in combination with Zarlink, or non-Zarlink furnished goods or services may infringe patents or other intellectual property rights owned by Zarlink.

This publication is issued to provide information only and (unless agreed by Zarlink in writing) may not be used, applied or reproduced for any purpose nor form part of any order or contract nor to be regarded as a representation relating to the products or services concerned. The products, their specifications, services and other information appearing in this publication are subject to change by Zarlink without notice. No warranty or guarantee express or implied is made regarding the capability, performance or suitability of any product or service. Information concerning possible methods of use is provided as a guide only and does not constitute any guarantee that such methods of use will be satisfactory in a specific piece of equipment. It is the user's responsibility to fully determine the performance and suitability of any equipment using such information and to ensure that any publication or data used is up to date and has not been superseded. Manufacturing does not necessarily include testing of all functions or parameters. These products are not suitable for use in any medical products whose failure to perform may result in significant injury or death to the user. All products and materials are sold and services provided subject to Zarlink's conditions of sale which are available on request.

Purchase of Zarlink's I<sup>2</sup>C components conveys a licence under the Philips I<sup>2</sup>C Patent rights to use these components in and I<sup>2</sup>C System, provided that the system conforms to the I<sup>2</sup>C Standard Specification as defined by Philips.

Zarlink, ZL and the Zarlink Semiconductor logo are trademarks of Zarlink Semiconductor Inc.

Copyright Zarlink Semiconductor Inc. All Rights Reserved.

**TECHNICAL DOCUMENTATION - NOT FOR RESALE**

---