

300mA Driving Capability

DESCRIPTION

The ST6850 is the current mode PWM controller with green-mode power-saving operation which can meet the low standby-power needs for low power SMPS. This green-mode function enables the power supply to easily meet even the strictest power conservation requirements. The small package provides the high efficiency / low cost solution for SMPS power applications.

ST6850 is processed by BiCMOS fabrication, that enables reducing the start-up current and the operating current. ST6850 is available by SOT-23-6L / DIP-8P packages.

PIN CONFIGURATION

SOT-23-6L

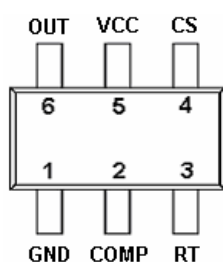

DIP-8P

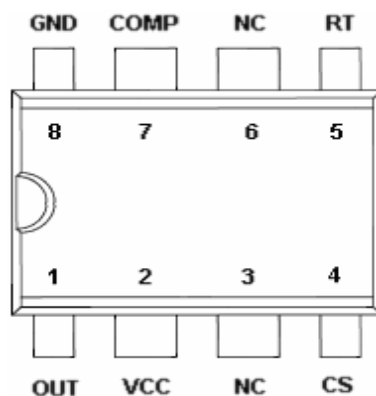

PART MARKING

SOT-23-6L

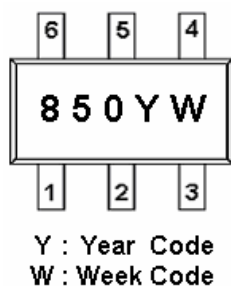

DIP-8P

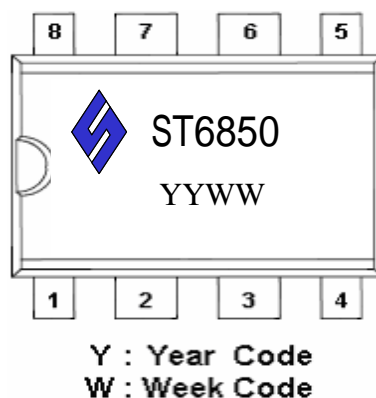

APPLICATIONS

- AC / DC Switching Power Adaptor
- Battery Charger
- PC 5V Standby Power
- Open-Frame Switching Power Supply

FEATURE

- High-Voltage BiCMOS Process
- Very Low Startup Current(<25u)
- Under Voltage Lockout(UVLO)
- Current Mode Control
- Current Limiting
- Programmable Switching Frequency
- Internal Slope Compensation
- Green-Mode Control for Power Saving
- Non-audible-noise Green Mode Control
- 300mA Driving Capability
- OVP (Over Voltage Protection) on Vcc Pin



STANSON TECHNOLOGY

120 Bentley Square, Mountain View, Ca 94040 USA
TEL: (650) 9389294 FAX: (650) 9389295

300mA Driving Capability

TYPICAL APPLICATION CIRCUIT (High Efficiency SMPS)

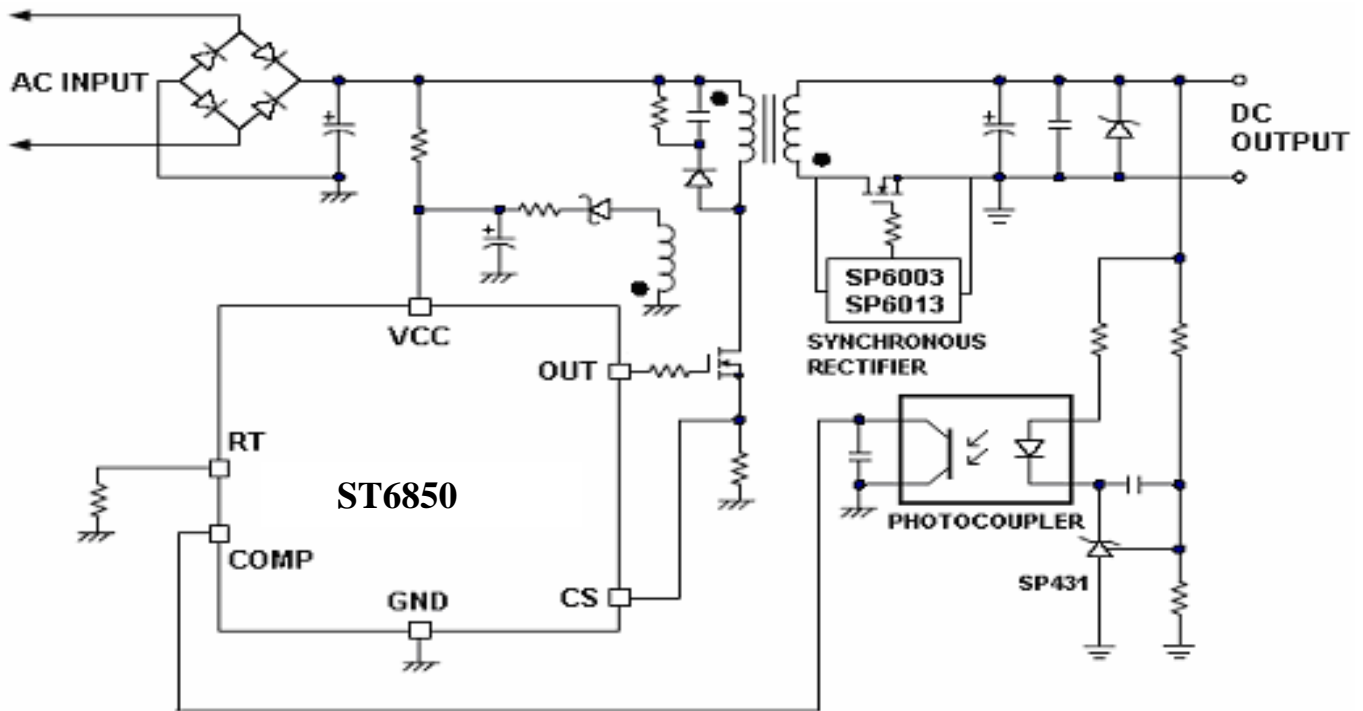

PIN DESCRIPTION

ST6850D8T

Pin	Symbol	Description
1	OUT	Gate driver output to drive the external MOSFET
2	VCC	Supply Voltage
3	NC	Unconnected pin
4	CS	Current sense. This pin senses the voltage across a resistor, to control PWM output. This pin also provides current amplitude information for current-mode control.
5	RT	This pin is used to charge an internal capacitor, to determine the switching frequency.
6	NC	Unconnected pin
7	COMP	Voltage feedback. The pin provides the output voltage regulation signal. It provides feedback to the internal PWM comparator, so that the PWM comparator can control the duty cycle.
8	GND	Ground



STANSON TECHNOLOGY

120 Bentley Square, Mountain View, Ca 94040 USA

TEL: (650) 9389294 FAX: (650) 9389295

300mA Driving Capability

SP6850S26R

Pin	Symbol	Description
1	GND	Ground
2	COMP	Voltage feedback. The pin provides the output voltage regulation signal.. It provides feedback to the internal PWM comparator, so that the PWM comparator can control the duty cycle.
3	RT	This pin is used to charge an internal capacitor, to determine the switching frequency.
4	CS	Current sense. This pin senses the voltage across a resistor, to control PWM output. This pin also provides current amplitude information for current-mode control.
6	VCC	Supply Voltage
7	OUT	Gate driver output to drive the external MOSFET

**STANSON TECHNOLOGY**

120 Bentley Square, Mountain View, Ca 94040 USA

TEL: (650) 9389294 FAX: (650) 9389295

BLOCK DIAGRAM

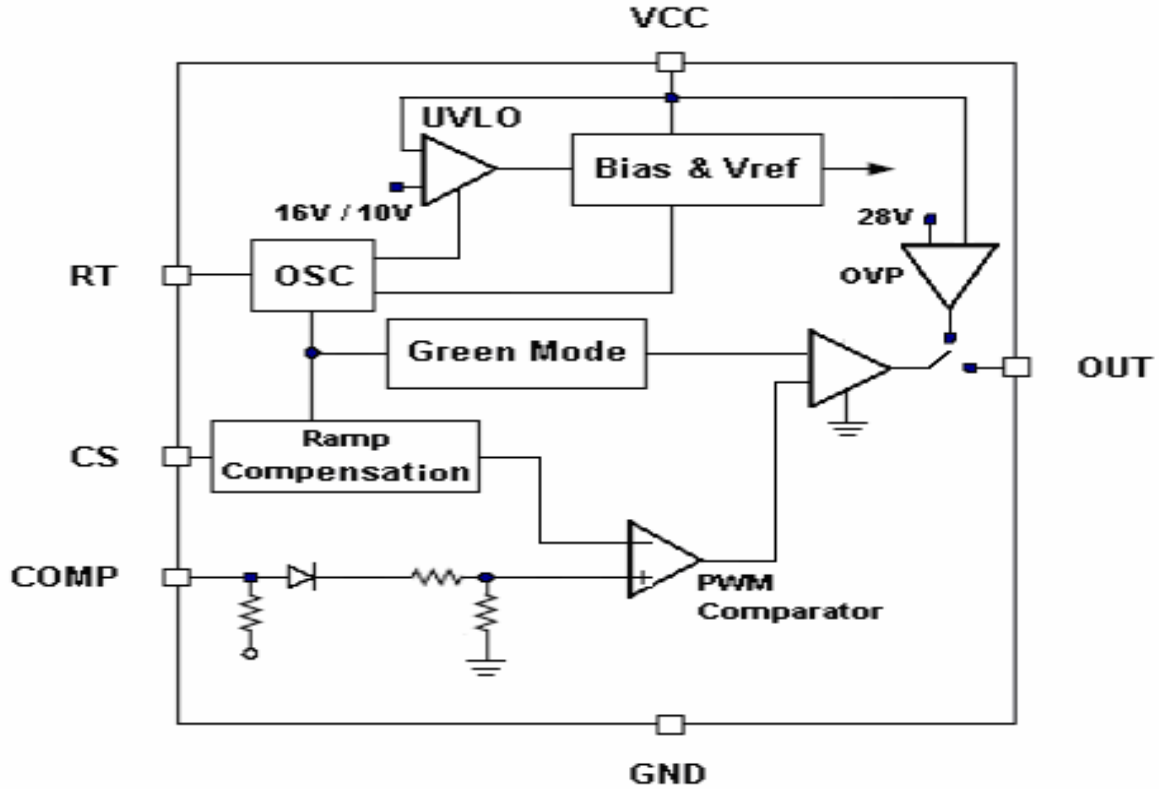

ORDERING INFORMATION

Part Number	Package	Part Marking
ST6850D8TG	DIP-8P	ST6850
ST6850S26RG	SOT-23-6L	805YW

ST6850D8T : Tube; Pb – Free

ST6850S26R: Tape Reel; Pb - Free



STANSON TECHNOLOGY

120 Bentley Square, Mountain View, Ca 94040 USA

TEL: (650) 9389294 FAX: (650) 9389295

300mA Driving Capability**ABSOLUTE MAXIMUM RATINGS** ($T_a=25$, unless otherwise specified.)

The following ratings designate persistent limits beyond which damage to the device may occur.

Symbol	Parameter	Value	Unit
V _{cc}	DC Supply Voltage	40	V
C _{comp} / R _t / C _s	SYNC	-3~7	V
P _d	Power Dissipation @ $T_a=85$ *	0.3	W
P _j	Operating Junction Temperature Range	150	
T _{stg}	Storage Temperature Range	150	
T _{lead}	Lead Soldering Temperature for 5 sec	SOT-23-6L 220 DIP-8P 260	
R _{jc}	Thermal Resistance Junction-Case(*)	SOT-23-6L 95 DIP-8P 210	/W

(*)The power dissipation and thermal resistance are evaluated under copper board mounted with free air conditions.

**STANSON TECHNOLOGY**

120 Bentley Square, Mountain View, Ca 94040 USA

TEL: (650) 9389294 FAX: (650) 9389295

300mA Driving Capability

ELECTRICAL CHARACTERISTICS (Ta=25 °C, Vcc=15V, unless otherwise specified.)

Symbol	Parameter	Conditions	Min.	Typ.	Max.	Unit
Supply Voltage (Vcc Pin)						
Istt	Startup Current			8	25	uA
Iop	Operating Current	Vcomp=3V		2	4	mA
UVLO(off)	Min. Operatinf Voltage		9.0	10.0	11.0	V
UVLO(on)	Start Threshold Voltage		15.0	16.0	17.0	V
Voltage Feedback (Comp Pin)						
Isc	Short Circuit Current			2.2	3.0	mA
Vop	Open Loop Voltage			5.0		V
Vth(gm)	Green Mode Threshold VCOMP			2.35		V
Oscillator (RT Pin)						
Fosc	Frequency	Rt=100K	60.0	65.0	70.0	KHz
Fosc(gm)	Green Mode Frequency	Fs=65.0KHz		20		KHz
Fdt	Frequency Variation versus Temp Deviation	(-40 ~105 °C)			3	%
Fdv	Frequency Variation versus Vcc Deviation	(Vcc=11V ~ 25V)			1	%
Current Sensing (CS Pin)						
Vcs(off)	Maximum Input Vlotage		0.8	0.85	0.9	V
Zcs	Input impedance			50		K
Tpd	Delay to Output			150		nS
Gate Driver Output (OUT pin)						
VOL	Output Low level	Vcc=15V, Io=20mA			1	V
VOH	Output High Level	Vcc=15V, Io=20mA	8			V
Tr	Rising Time	Load Cap=1000pF		50	200	nS
Tf	Falling Time	Load Cap=1000pF		30	120	nS

**STANSON TECHNOLOGY**

120 Bentley Square, Mountain View, Ca 94040 USA

TEL: (650) 9389294 FAX: (650) 9389295

300mA Driving Capability

PERFORMANCE CHARACTERISTICS (Ta=25 , unless otherwise specified.)

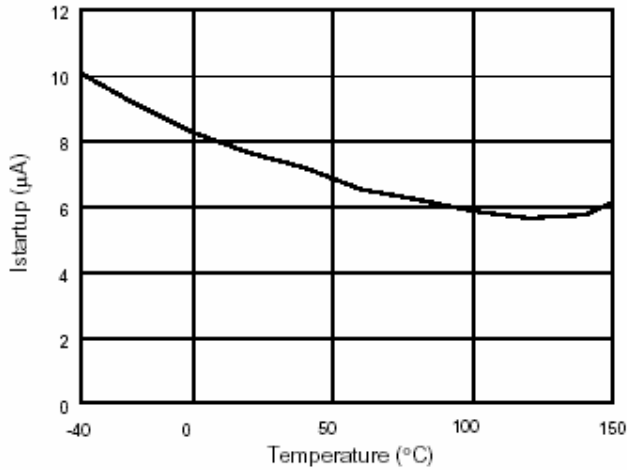

Fig. 1 Startup Current (I_{startup}) vs. Temperature

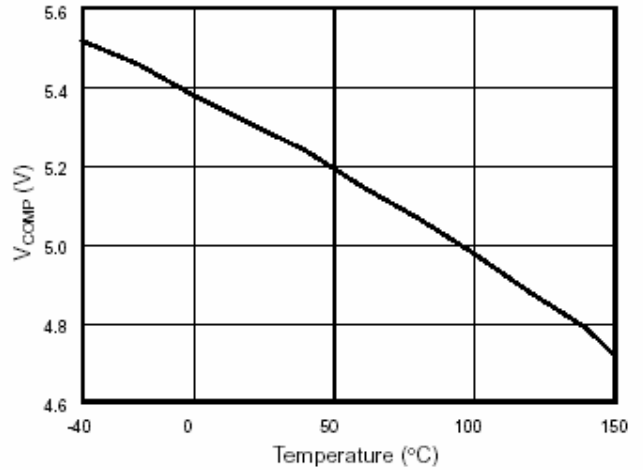

Fig. 2 V_{COMP} open loop voltage v.s. Temperature

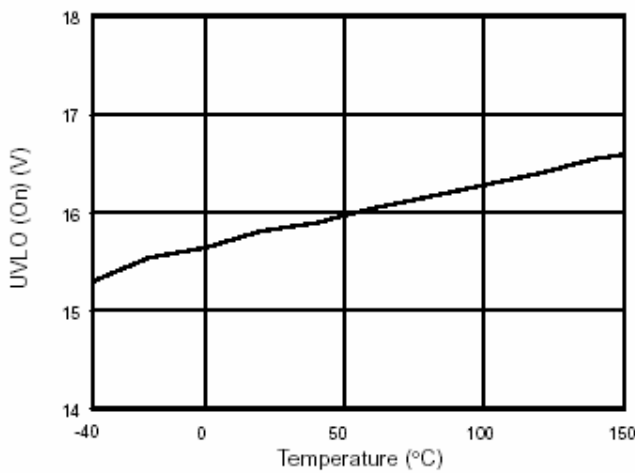

Fig. 3 UVLO (On) vs. Temperature

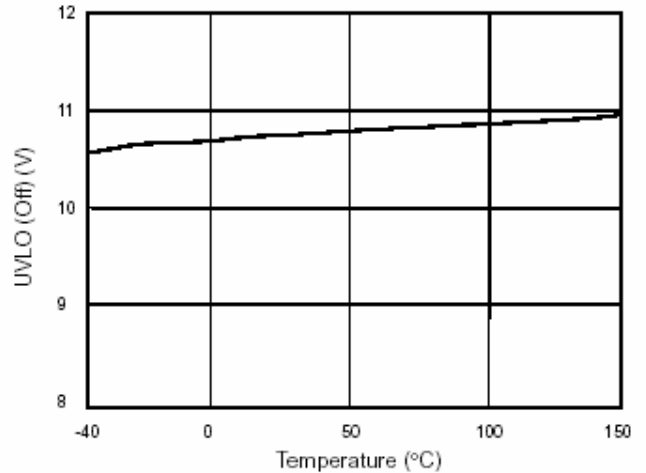

Fig. 4 UVLO Off v.s. Temperature

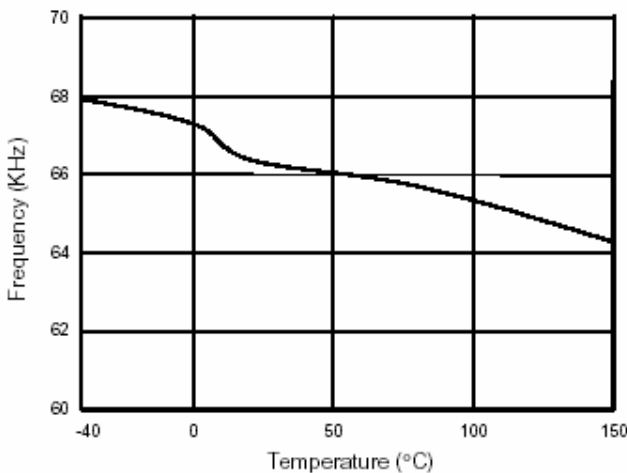

Fig. 5 Frequency v.s. Temperature

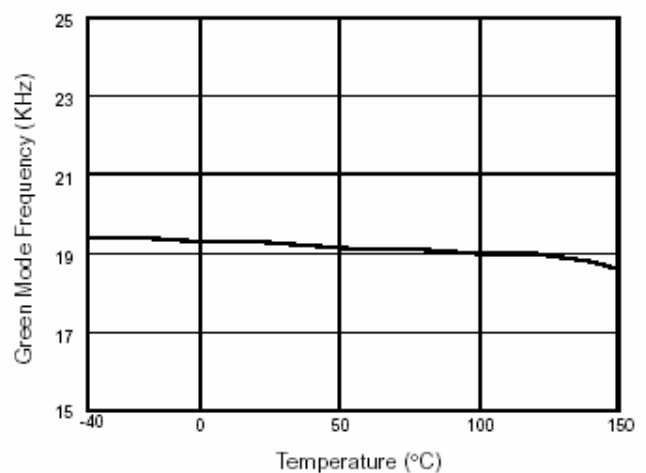

Fig. 6 Green Mode Frequency v.s. Temperature

300mA Driving Capability

PERFORMANCE CHARACTERISTICS

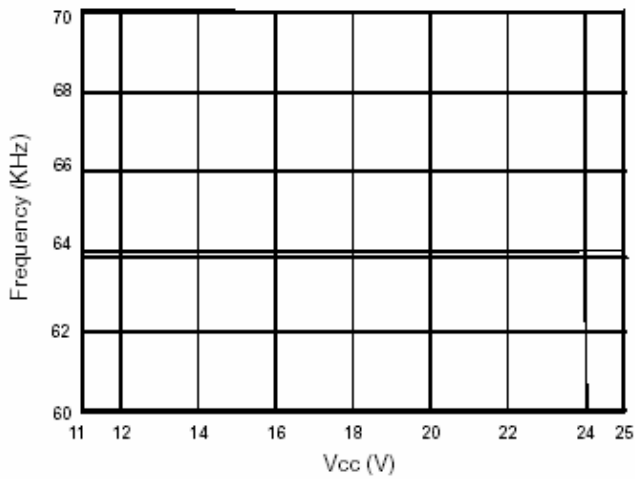

Fig. 7 Frequency v.s. Vcc

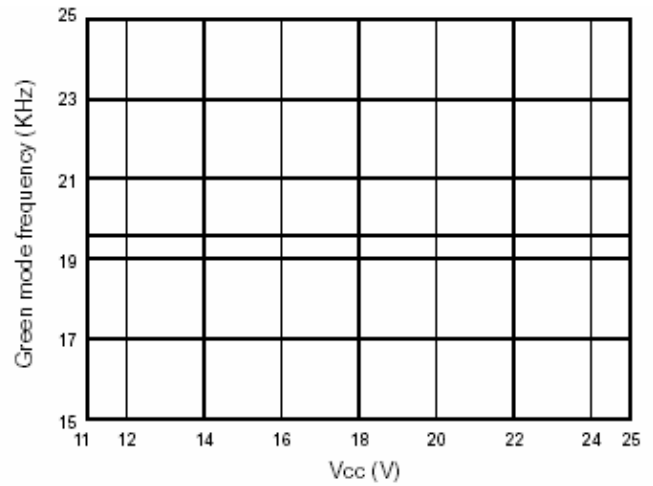

Fig. 8 Green mode frequency v.s. Vcc

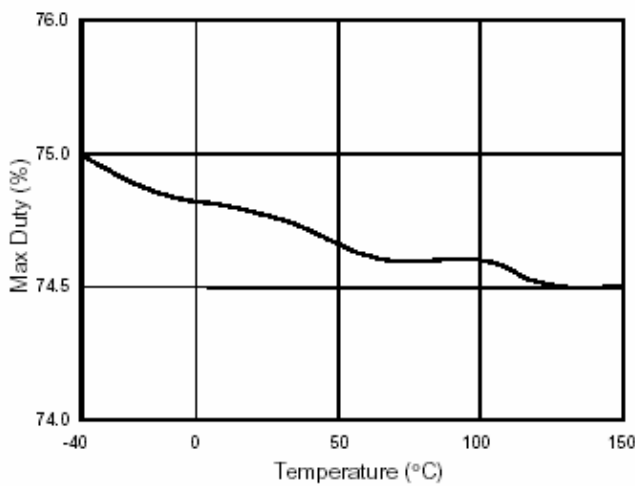

Fig. 9 Max Duty v.s. Temperature

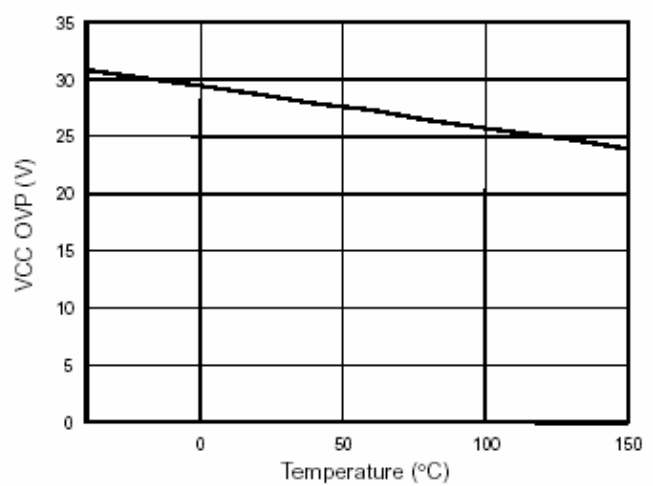

Fig. 10 VCC OVP v.s. Temperature

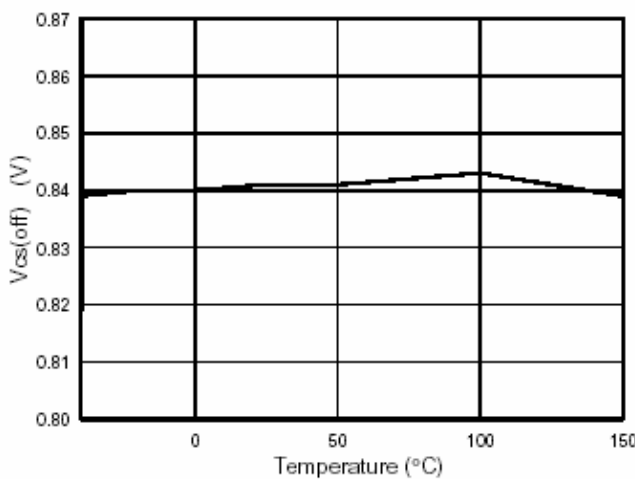
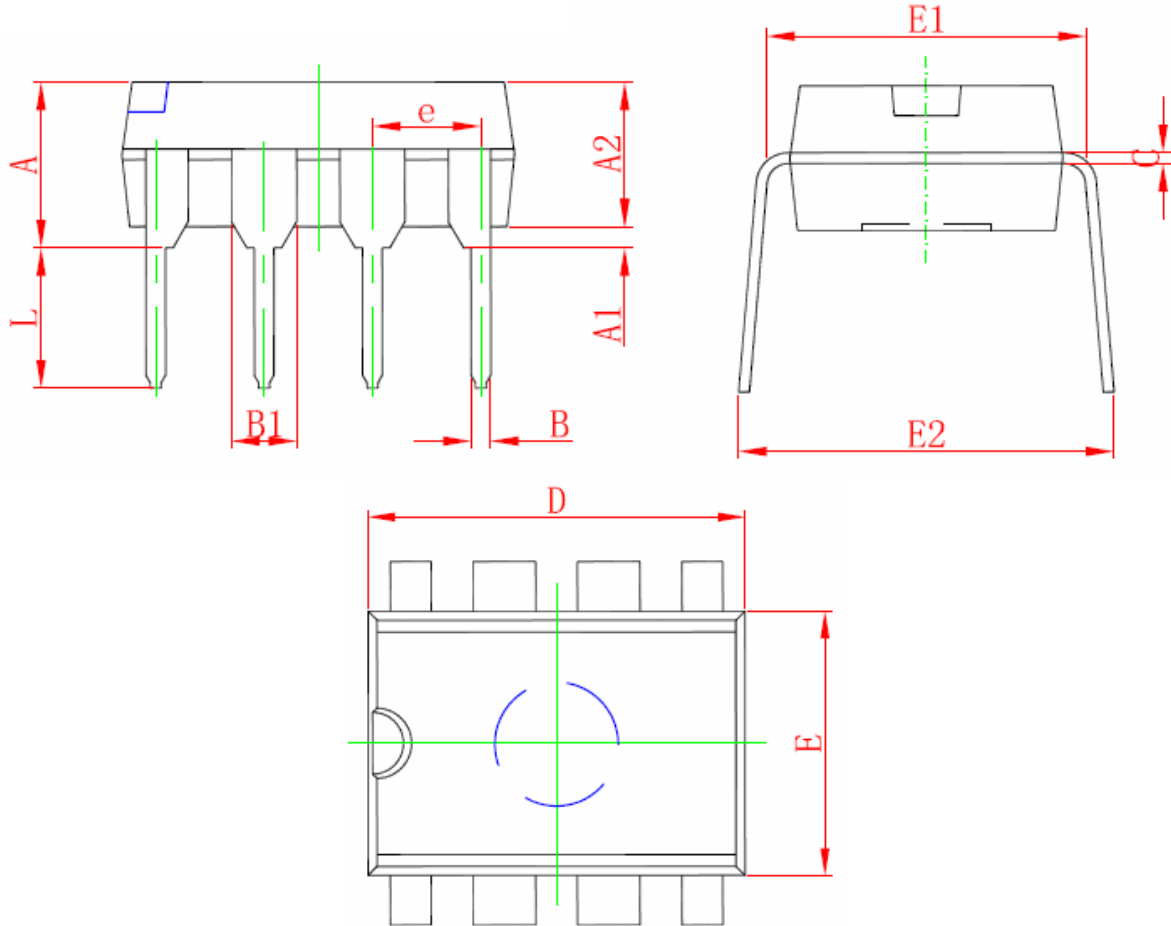

Fig. 11 Vcs (off) v.s. Temperature

DIP- 8P PACKAGE OUTLINE



Symbol	Dimensions In Millimeters		Dimensions In Inches	
	Min	Max	Min	Max
A	3.710	4.310	0.146	0.170
A1	0.510		0.020	
A2	3.200	3.600	0.126	0.142
B	0.380	0.570	0.015	0.022
B1	1.524 (BSC)		0.060 (BSC)	
C	0.204	0.360	0.008	0.014
D	9.000	9.400	0.354	0.370
E	6.200	6.600	0.244	0.260
E1	7.320	7.920	0.288	0.312
e	2.540 (BSC)		0.100 (BSC)	
L	3.000	3.600	0.118	0.142
E2	8.400	9.000	0.331	0.354



STANSON TECHNOLOGY

120 Bentley Square, Mountain View, Ca 94040 USA

TEL: (650) 9389294 FAX: (650) 9389295

300mA Driving Capability

SOT-23-6L PACKAGE OUTLINE

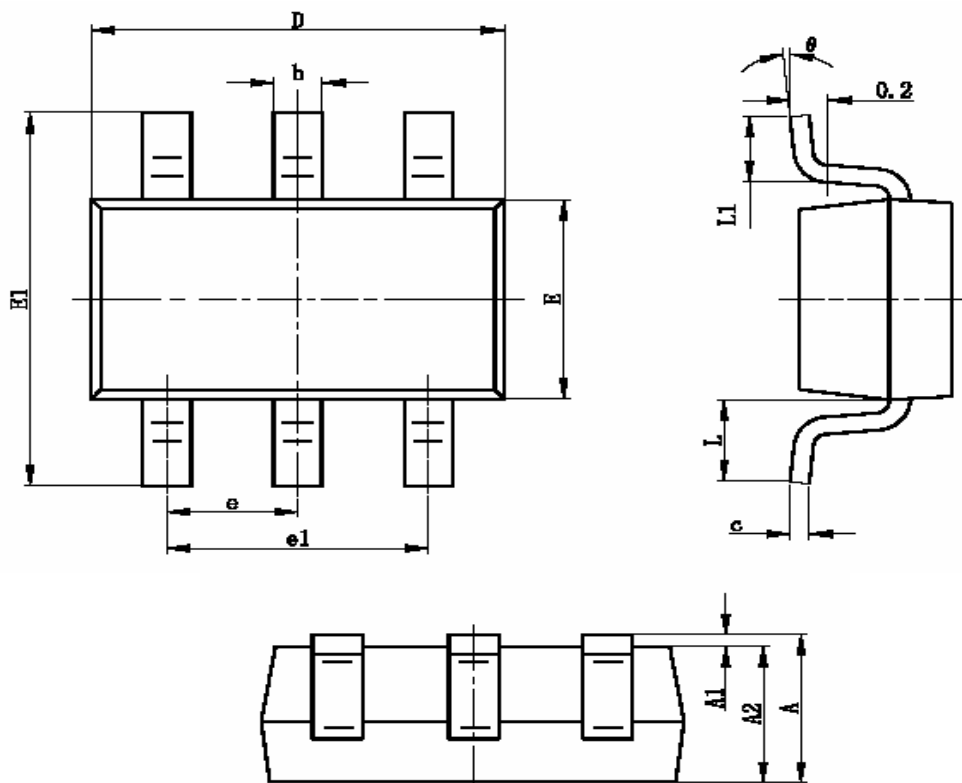

Symbol	Dimensions In Millimeters		Dimensions In Inches	
	Min	Max	Min	Max
A	1.050	1.250	0.041	0.049
A1	0.000	0.100	0.000	0.004
A2	1.050	1.150	0.041	0.045
b	0.300	0.400	0.012	0.016
c	0.100	0.200	0.004	0.008
D	2.820	3.020	0.111	0.119
E	1.500	1.700	0.059	0.067
E1	2.650	2.950	0.104	0.116
e	0.950TYP		0.037TYP	
e1	1.800	2.000	0.071	0.079
L	0.700REF		0.028REF	
L1	0.300	0.600	0.012	0.024
θ	0°	8°	0°	8°

**STANSON TECHNOLOGY**

120 Bentley Square, Mountain View, Ca 94040 USA

TEL: (650) 9389294 FAX: (650) 9389295