

Typical Applications

- 3.6V Analog Handsets
- Analog Communication Systems
- 400MHz Industrial Radios
- Portable Battery Powered Equipment

Product Description

The RF2117 is a high power amplifier IC. The device is manufactured on an advanced Gallium Arsenide Hetero-junction Bipolar Transistor (HBT) process, and has been designed for use as the final RF amplifier in analog cellular phone transmitters between 400MHz and 500MHz or ISM applications operating at 433MHz. The device is packaged in a low cost 16-lead plastic package with a metal backside. The device is self-contained with the exception of the output matching network and power supply feed line.

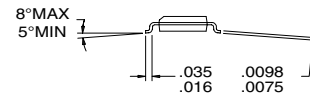
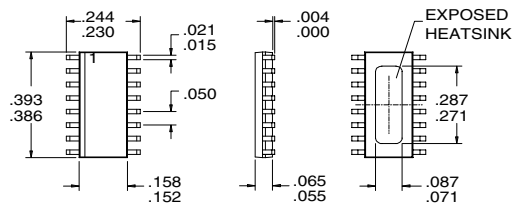

Package Weight typically 0.22 grams

Optimum Technology Matching® Applied

- Si BJT GaAs HBT GaAs MESFET
 Si Bi-CMOS SiGe HBT Si CMOS

Package Style: PSOP-16

Features

- Single 3V to 5.5V Supply
- Up to 2W CW Output Power
- 33dB Small Signal Gain
- >50% Efficiency
- 400MHz to 500MHz Operation

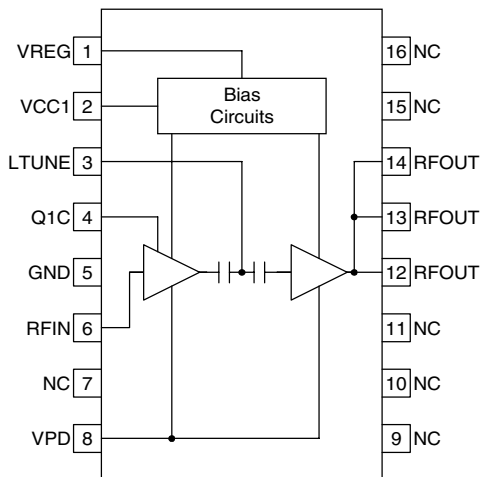

Functional Block Diagram

Ordering Information

- RF2117 High Efficiency 400MHz Amplifier
 RF2117 PCBA Fully Assembled Evaluation Board

RF Micro Devices, Inc.
 7625 Thorndike Road
 Greensboro, NC 27409, USA

Tel (336) 664 1233
 Fax (336) 664 0454
<http://www.rfmd.com>

Absolute Maximum Ratings

Parameter	Rating	Unit
Supply Voltage (V_{CC})	-0.5 to +6.0	V_{DC}
Power Down Voltage (V_{PD})	-0.5 to +3.0	V
DC Supply Current	1300	mA
Input RF Power	+10	dBm
Output Load	7:1	
Operating Case Temperature	-40 to +100	°C
Operating Ambient Temperature	-40 to +85	°C
Storage Temperature	-55 to +150	°C



Caution! ESD sensitive device.

RF Micro Devices believes the furnished information is correct and accurate at the time of this printing. However, RF Micro Devices reserves the right to make changes to its products without notice. RF Micro Devices does not assume responsibility for the use of the described product(s).

Parameter	Specification			Unit	Condition
	Min.	Typ.	Max.		
Overall					$T=25^{\circ}\text{C}$, $V_{CC}=3.6\text{V}$, $V_{PD}=2.2\text{V}$, $Z_{LOAD}=2.7\Omega$, $P_{IN}=4\text{dBm}$, $\text{Freq}=450\text{MHz}$
Frequency Range		400 to 500		MHz	
Maximum CW Output Power		+33		dBm	
	+32.5			dBm	$V_{CC}=3.2$ to 4.5V $T_{amb}=-25$ to $+85^{\circ}\text{C}$
	+31.5			dBm	$V_{CC}=3.0$ to 3.2V and 4.5 to 5.5V
Total CW Efficiency	52	55		%	$V_{CC}=3.0\text{V}$ $P_{out}=+32.5\text{dBm}$
		45		%	$V_{CC}=3.6\text{V}$ $P_{out}=+32.5\text{dBm}$
Small-signal Gain		33		dB	
Harmonics	-30	-40		dBc	$V_{CC}=3.0$ to 5.5V $T_{amb}=-25$ to $+85^{\circ}\text{C}$
All Other Spurious			-70	dBc	Load $VSWR \leq 6:1$ all phase angles, $Z_s=50\Omega$, $V_{CC}=3.0\text{V}$ to 5.5V , $T_{amb}=-30$ to $+85^{\circ}\text{C}$
Input VSWR		<2:1			
Input Power	+2	+4	+6	dBm	
Input Impedance		50		Ω	
Noise Power in Rx Band			-80dBm	dBm	$P_{out}=+32.5\text{dBm}$, $\text{Freq.}=410$ to 485MHz , $T_{amb}=-30$ to $+85^{\circ}\text{C}$ $VSWR \leq 6:1$ all phase angles.
Intermodulation Conversion at TX Freq. - 10MHz	12			dB	$P_{out}=+15\text{dBm}$ to $+32.5\text{dBm}$
Power Down Isolation	45			dB	VPD grounded through $1\text{k}\Omega$ resistor $P_{in}=+6\text{dBm}$
Power Control					
Control Voltage VPD	0		2.4	V	
Control Current			6	mA	
Gain Control	35			dB	
Power Supply					
Power Supply Voltage	3.0	3.6	5.3	V	DC Current at POUT,MAX
Power Supply Current		1100		mA	
Regulated Voltage VREG	2.7	2.8	2.9	V	
Current from VREG			12	mA	

Pin	Function	Description	Interface Schematic
1	VREG	Regulated Supply for bias circuit. This pin should be connected to the regulated supply with a ferrite of 240 ohms and should have a UHF decoupling capacitor (100pF) to ground at the supply end of the ferrite. An additional capacitor of 1nF can be added with the 100 pF but it's placement is not as critical.	
2	VCC1	Positive supply for the active bias circuits. Bypassing should be accomplished with a single UHF decoupling capacitor, placed close to the Pin. Additional bypassing of 1 nF is also recommended, but proximity to the package is not as critical.	
3	LTUNE	The Inter-stage matching point of the amplifiers. Matching should be performed with a small value inductor connected from the pin to ground.	
4	Q1C	Positive Supply to the first stage collector. The supply should be fed through a parallel LC network, resonant at the centre of the band of interest. A UHF decoupling capacitor should be placed from the supply end of the LC to ground. A 1nF capacitor can also be used but it's placement it not as critical.	
5	GND	Ground Contact for the driver stage. Keep traces physically short and connect immediately to the ground plane for best performance. It is important for stability that this pin has it's own via to the groundplane, to minimize any common inductance.	
6	RF IN	Amplifier RF input. This is a 50Ω RF input port to the amplifier. It does not contain internal DC blocking and therefore should be externally DC blocked before connecting to any device which has DC present or which contains a DC path to ground. A series UHF capacitor is recommended for the DC blocking.	
7	NC	Not internally connected.	
8	VPD	Power Down control. When this pin is "low" all circuits are off. A low is typically less than 0.5V at room temperature. This pin affords a measure of power control, however this response is not linear across much of the range. It is recommended that the pin be used in closed loop power control systems if it is to be used across a range of voltages and temperatures for power control.	
9	NC	Not internally connected.	
10	NC	Not internally connected.	
11	NC	Not internally connected.	
12	RF OUT	Amplifier RF output. This is an unmatched collector output of the final amplifier transistor. It is internally connected to pins 12, 13, and 14 to provide low series inductance and flexibility in output matching. Bias for the final power amplifier output transistor must also be provided through two of these three pins. Typically, these pins are externally connected very close to the package and used as the RF output with a matching network that presents the optimum load impedance to the PA for maximum power and efficiency, as well as providing DC blocking at the output. An additional network of a bias inductor (or $\lambda/4$ line) provides DC bias and helps to protect the output from high voltage swings due to severe load mismatches.	
13	RF OUT	Amplifier RF output, same as pin 12	
14	RF OUT	Amplifier RF output, same as pin 12. Do not feed the supply to this pin alone. If this pin is used as the supply pin it must be connected in parallel with pin 12 and/or 13.	
15	NC	Not internally connected.	
16	NC	Not internally connected.	
Pkg Base	GND	This contact is the main ground contact for the entire device. Care should be taken to ensure that this contact is well soldered in order to prevent performance from being degraded from that indicated in the specifications.	

**Application Schematic
450MHz**

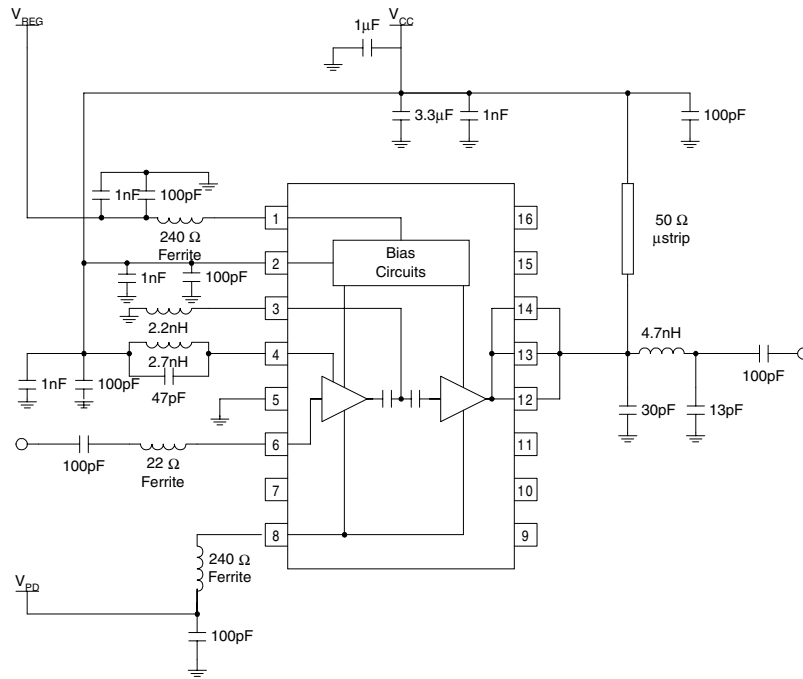

Application Schematic 220 MHz

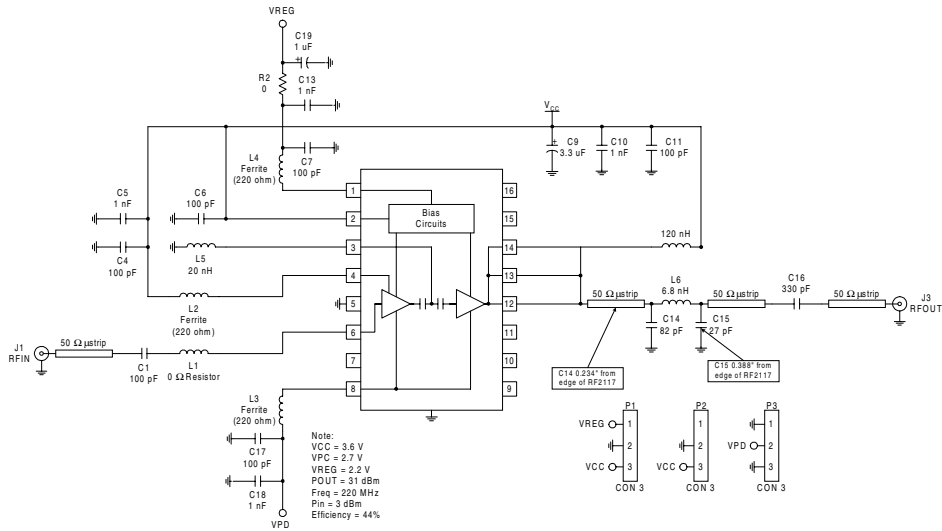

Evaluation Board Schematic
 (Download [Bill of Materials](http://www.rfmd.com) from www.rfmd.com.)

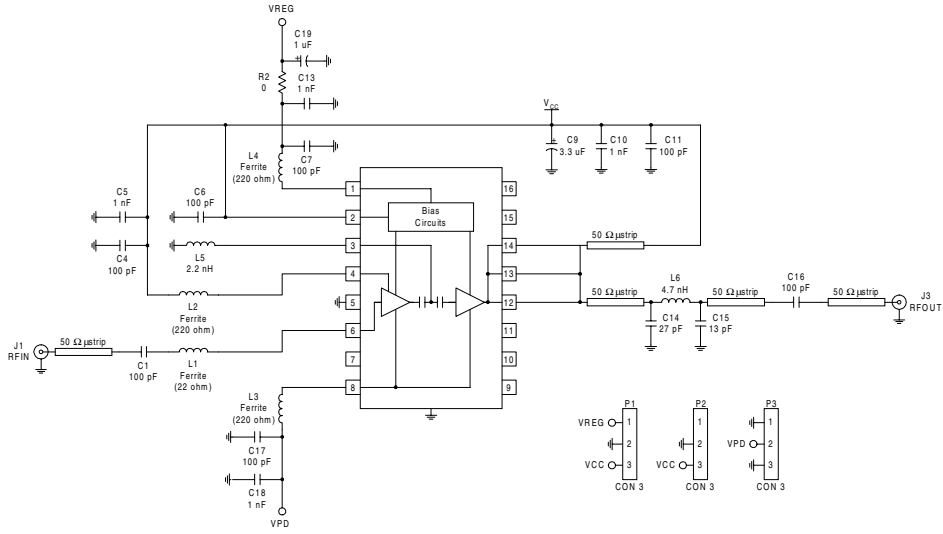

POWER AMPLIFIERS 2

Evaluation Board Layout 2" x 3"

