

Printheads

For Photo Color Printers

(310DPI;dots/inch)

NE3104-VC11A

NE3104-VC11 series is newly developed for photo color printers as (color print) thermal printheads, high speed, high quality printing is achieved with several new technologies. Printing method is available for sublimation type of thermal transference.

● **Application**

Home printer

Photo KIOSK

● **Features**

- 1) 9° tit-angle with near-edge structure to work with larger platen.
- 2) High quality printing with less uneven imaging by employing the glaze of very little undulation.
- 3) Resistance variance less than $\pm 1\%$ in the head using special pulse trimming technologies.

● **External Dimension (Unit:mm)**

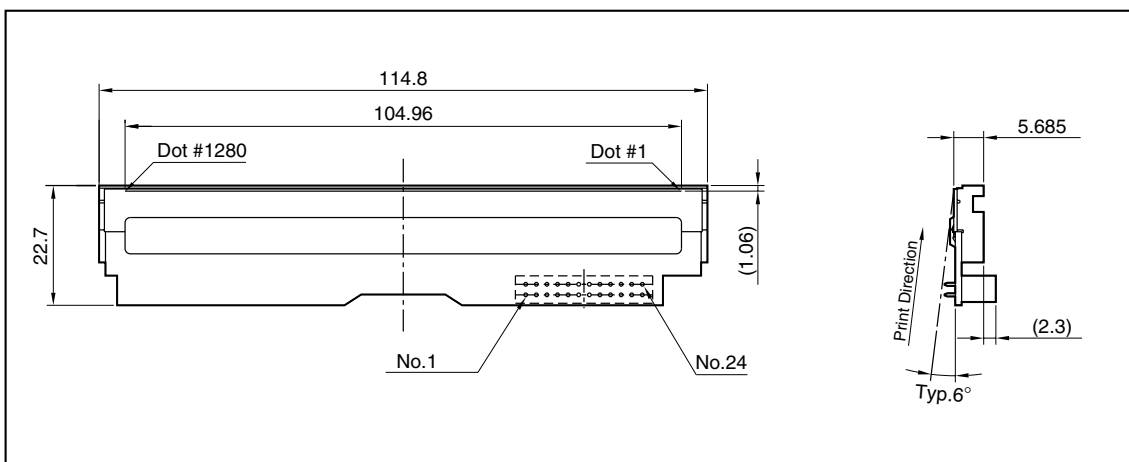
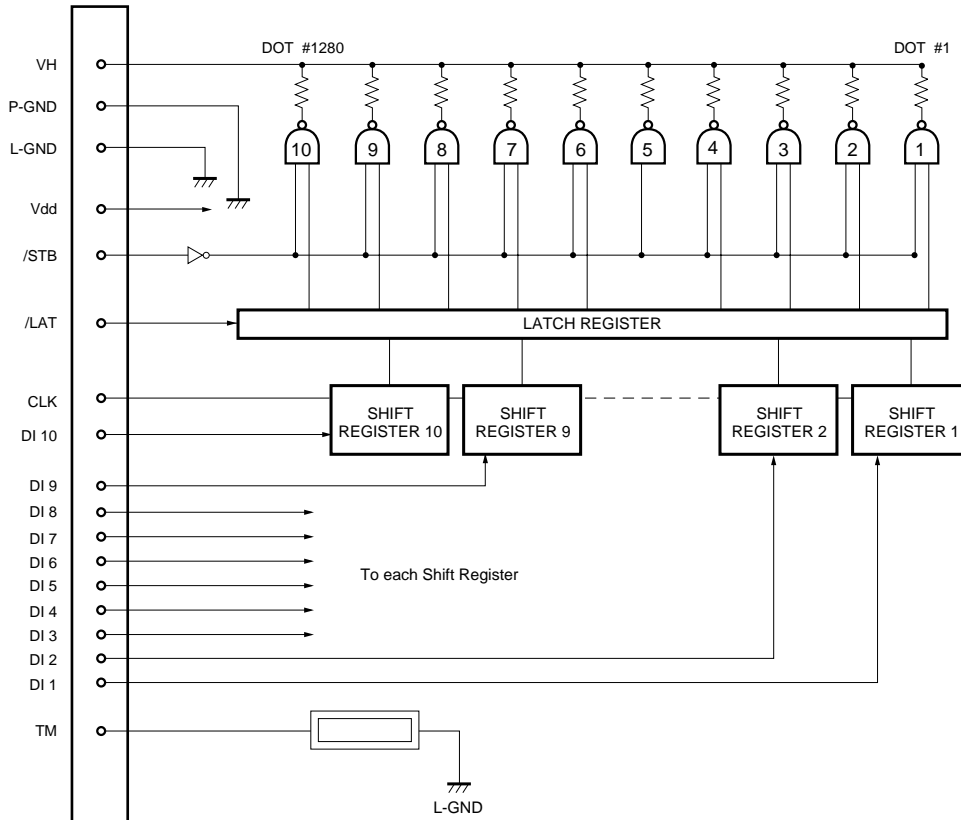

Fig. 1 External Dimension

Note : No heat control function inside the thermal printhead. External heat history control is required for high speed printing.

Printheads

● Equivalent circuit



DI No.	Dot No.	DI No.	Dot No.
10	1280 to 1153	5	640 to 513
9	1152 to 1025	4	512 to 385
8	1024 to 897	3	384 to 257
7	896 to 769	2	256 to 129
6	768 to 641	1	128 to 1

Fig. 2 Equivalent circuit

Printheads

● Pin assignments

No.	Circuit	No.	Circuit	No.	Circuit
1	V _H	2	V _H	3	V _H
4	V _H	5	P-GND	6	P-GND
7	P-GND	8	P-GND	9	TM
10	L-GND	11	VDD	12	DI10
13	DI9	14	DI8	15	DI7
16	DI6	17	DI5	18	DI4
19	DI3	20	DI2	21	DI1
22	CLK	23	/STB	24	/LAT

● Timing chart

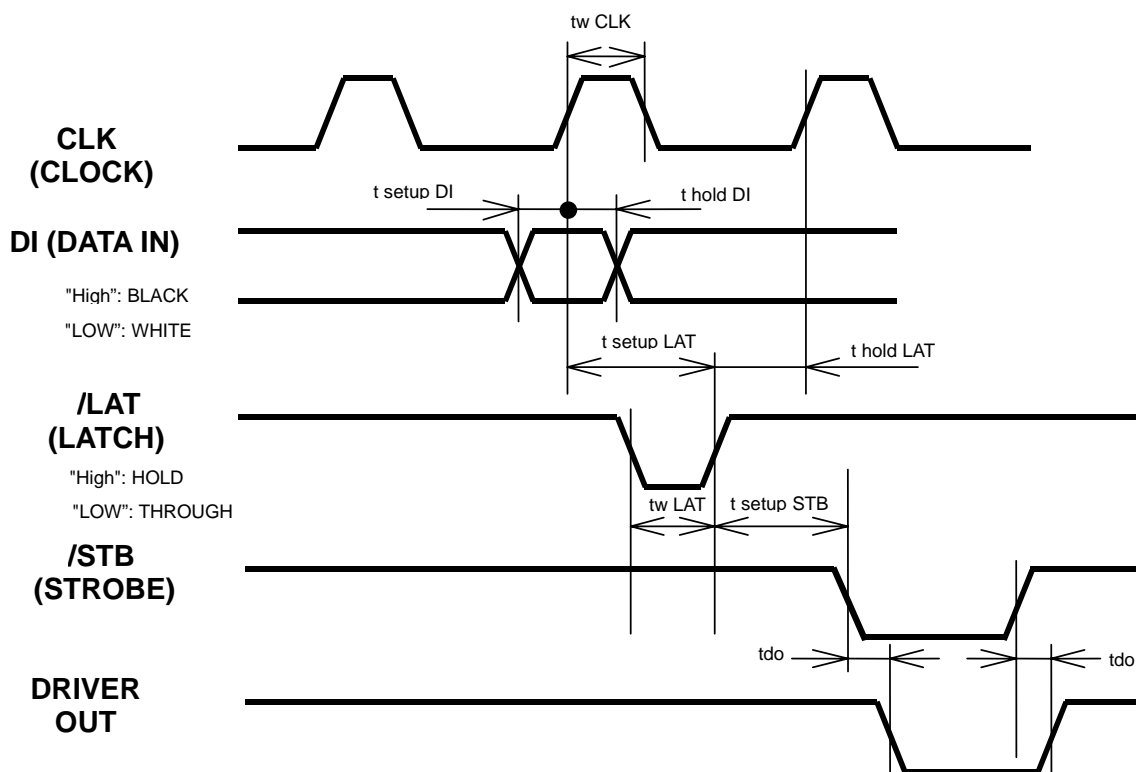

Fig. 3 Timing chart

Printheads

● Characteristics

Parameter	Symbol	Typical	Unit
Effective printing width		104.96	mm
Dot pitch		0.0820	mm
Total dot number		1280	dots
Average resistance value	R_{ave}	5400	Ω
Applied voltage	V_H	24	V
Applied power	P_0	0.102	W/dot
Print cycle	SLT	4.0	ms/line
Pulse width	T_{ON}	2.8	ms
Maximum number of dots energized simultaneously		1280	dots
Maximum clock frequency		10	MHz
Maximum rolls diameter		52	mm
Running life/pulse life		$2/5 \times 10^7$	km/pulses
Operating temperature		5 to 45	$^{\circ}\text{C}$

● Electrical characteristic

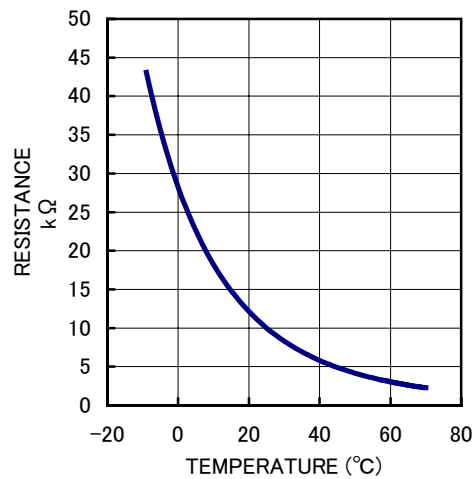

Fig. 4 Thermistor curve

Notes

- No technical content pages of this document may be reproduced in any form or transmitted by any means without prior permission of ROHM CO.,LTD.
- The contents described herein are subject to change without notice. The specifications for the product described in this document are for reference only. Upon actual use, therefore, please request that specifications to be separately delivered.
- Application circuit diagrams and circuit constants contained herein are shown as examples of standard use and operation. Please pay careful attention to the peripheral conditions when designing circuits and deciding upon circuit constants in the set.
- Any data, including, but not limited to application circuit diagrams information, described herein are intended only as illustrations of such devices and not as the specifications for such devices. ROHM CO.,LTD. disclaims any warranty that any use of such devices shall be free from infringement of any third party's intellectual property rights or other proprietary rights, and further, assumes no liability of whatsoever nature in the event of any such infringement, or arising from or connected with or related to the use of such devices.
- Upon the sale of any such devices, other than for buyer's right to use such devices itself, resell or otherwise dispose of the same, no express or implied right or license to practice or commercially exploit any intellectual property rights or other proprietary rights owned or controlled by
- ROHM CO., LTD. is granted to any such buyer.
- Products listed in this document are no antiradiation design.

The products listed in this document are designed to be used with ordinary electronic equipment or devices (such as audio visual equipment, office-automation equipment, communications devices, electrical appliances and electronic toys).

Should you intend to use these products with equipment or devices which require an extremely high level of reliability and the malfunction of which would directly endanger human life (such as medical instruments, transportation equipment, aerospace machinery, nuclear-reactor controllers, fuel controllers and other safety devices), please be sure to consult with our sales representative in advance.

About Export Control Order in Japan

Products described herein are the objects of controlled goods in Annex 1 (Item 16) of Export Trade Control Order in Japan.

In case of export from Japan, please confirm if it applies to "objective" criteria or an "informed" (by MITI clause) on the basis of "catch all controls for Non-Proliferation of Weapons of Mass Destruction.