



3.3V 8K/16K x 9 Synchronous Dual Port Static RAM

Features

- True Dual-Ported memory cells which allow simultaneous access of the same memory location
- Two Flow-Through/Pipelined devices
 - 8K x 9 organization (CY7C09159AV)
 - 16K x 9 organization (CY7C09169AV)
- Three Modes
 - Flow-Through
 - Pipelined
 - Burst
- Pipelined output mode on both ports allows fast 83-MHz operation
- 0.35-micron CMOS for optimum speed/power
- High-speed clock to data access 9 and 12 ns (max.)
- 3.3V Low operating power
 - Active = 135 mA (typical)
 - Standby = 10 μ A (typical)
- Fully synchronous interface for easier operation
- Burst counters increment addresses internally
 - Shorten cycle times
 - Minimize bus noise
 - Supported in Flow-Through and Pipelined modes
- Dual Chip Enables for easy depth expansion
- Automatic power-down
- Commercial and industrial temperature ranges
- Available in 100-pin TQFP

Logic Block Diagram

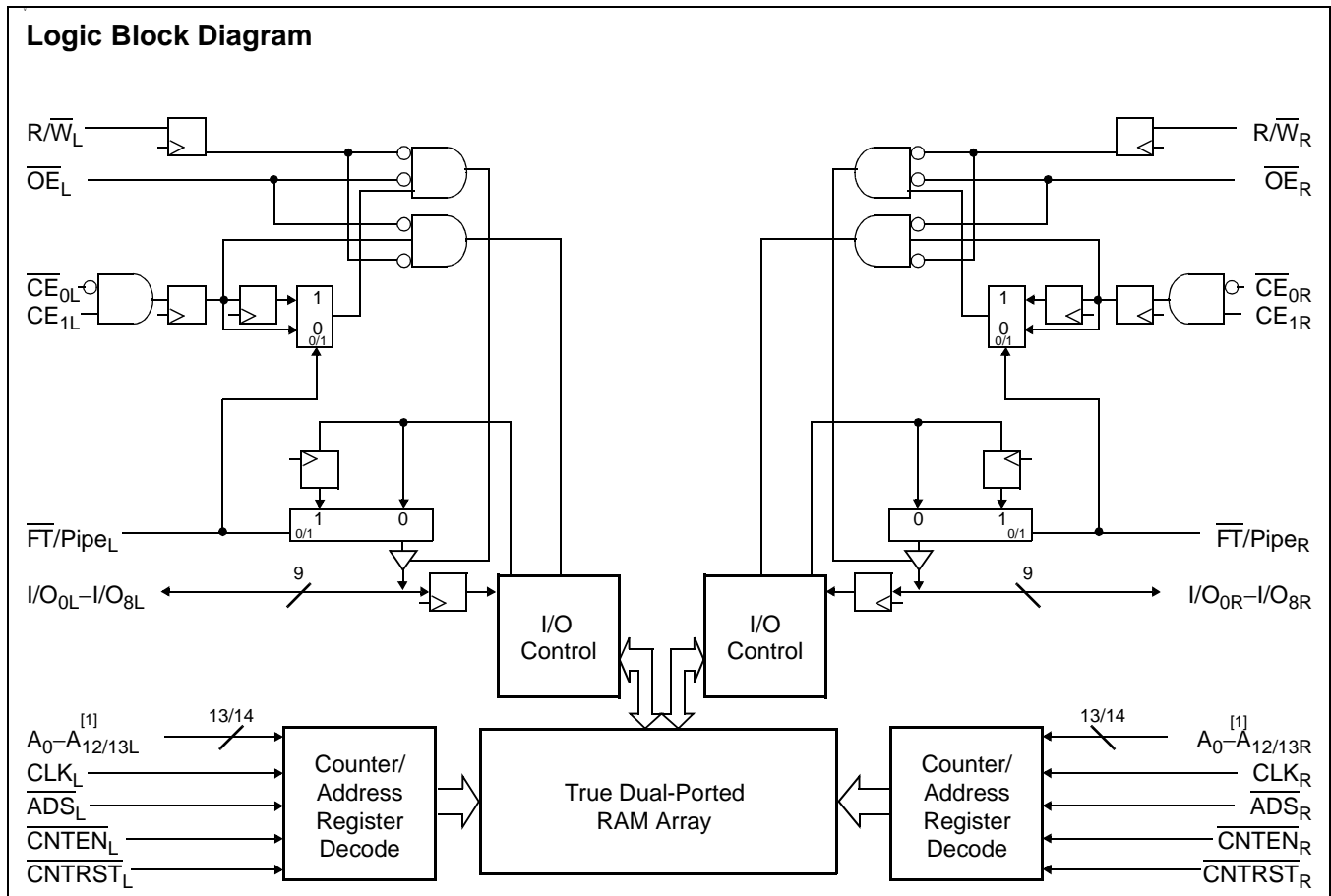

Notes:

1. A₀-A₁₂ for 8K; A₀-A₁₃ for 16K.

For the most recent information, visit the Cypress web site at www.cypress.com

Functional Description

The CY7C09159AV and CY7C09169AV are high-speed synchronous CMOS 8K and 16K x 9 dual-port static RAMs. Two ports are provided, permitting independent, simultaneous access for reads and writes to any location in memory.^[2] Registers on control, address, and data lines allow for minimal set-up and hold times. In pipelined output mode, data is registered for decreased cycle time. Clock to data valid $t_{CD2} = 9$ ns (pipelined). Flow-through mode can also be used to bypass the pipelined output register to eliminate access latency. In flow-through mode data will be available $t_{CD1} = 18$ ns after the address is clocked into the device. Pipelined output or flow-through mode is selected via the FT/Pipe pin.

Each port contains a burst counter on the input address register. The internal write pulse width is independent of the LOW-to-HIGH transition of the clock signal. The internal write pulse is self-timed to allow the shortest possible cycle times.

Note:

2. When simultaneously writing to the same location, final value cannot be guaranteed.

A HIGH on \overline{CE}_0 or LOW on CE_1 for one clock cycle will power down the internal circuitry to reduce the static power consumption. The use of multiple Chip Enables allows easier banking of multiple chips for depth expansion configurations. In the pipelined mode, one cycle is required with \overline{CE}_0 LOW and CE_1 HIGH to reactivate the outputs.

Counter enable inputs are provided to stall the operation of the address input and utilize the internal address generated by the internal counter for fast interleaved memory applications. A port's burst counter is loaded with the port's Address Strobe (ADS). When the port's Count Enable (\overline{CNTEN}) is asserted, the address counter will increment on each LOW-to-HIGH transition of that port's clock signal. This will read/write one word from/into each successive address location until \overline{CNTEN} is deasserted. The counter can address the entire memory array and will loop back to the start. Counter Reset (\overline{CNTRST}) is used to reset the burst counter.

All parts are available in 100-pin Thin Quad Plastic Flatpack (TQFP) packages.

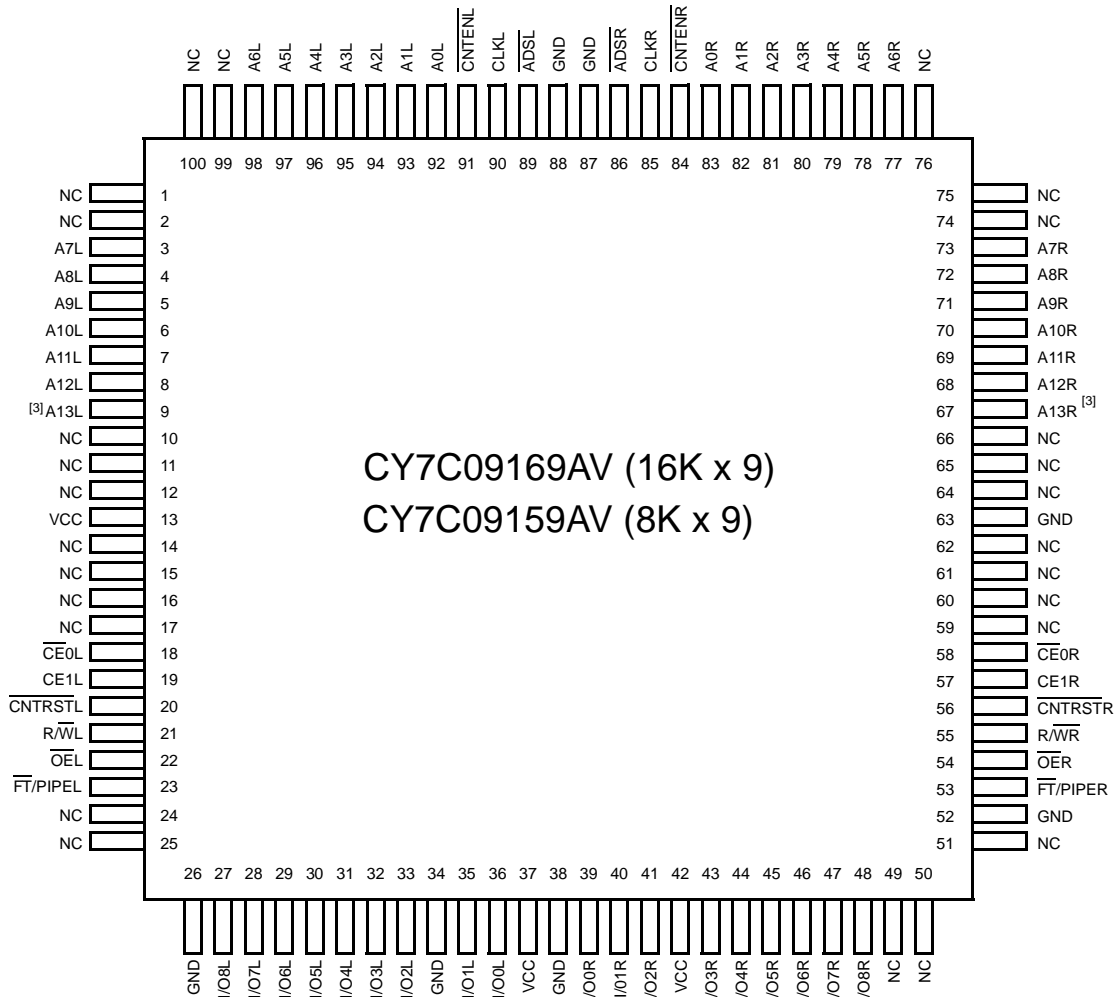
Pin Configuration
**100-Pin TQFP
(Top View)**

Note:

3. This pin is NC for CY7C09159AV.

Selection Guide

	CY7C09159AV CY7C09169AV -9	CY7C09159AV CY7C09169AV -12
f_{MAX2} (MHz) (Pipelined)	67	50
Max Access Time (ns) (Clock to Data, Pipelined)	9	12
Typical Operating Current I_{CC} (mA)	135	115
Typical Standby Current for I_{SB1} (mA) (Both Ports TTL Level)	20	20
Typical Standby Current for I_{SB3} (μ A) (Both Ports CMOS Level)	10 μ A	10 μ A

Pin Definitions

Left Port	Right Port	Description
A _{0L} -A _{13L}	A _{0R} -A _{13R}	Address Inputs (A ₀ -A ₁₂ for 8K; A ₀ -A ₁₃ for 16K devices).
ADS _L	ADS _R	Address Strobe Input. Used as an address qualifier. This signal should be asserted LOW during normal read or write transactions. Asserting this signal LOW also loads the burst address counter with data present on the I/O pins.
CE _{0L} , CE _{1L}	CE _{0R} , CE _{1R}	Chip Enable Input. To select either the left or right port, both CE ₀ AND CE ₁ must be asserted to their active states (CE ₀ ≤ V _{IL} and CE ₁ ≥ V _{IH}).
CLK _L	CLK _R	Clock Signal. This input can be free-running or strobed. Maximum clock input rate is f _{MAX} .
CNTEN _L	CNTEN _R	Counter Enable Input. Asserting this signal <u>LOW</u> increments the <u>burst address counter</u> of its respective port on each rising edge of CLK. CNTEN is disabled if ADS or CNTRST are asserted LOW.
CNTRST _L	CNTRST _R	Counter Reset Input. Asserting this signal LOW resets the burst address counter of its respective port to zero. CNTRST is not disabled by asserting ADS or CNTEN.
I/O _{0L} -I/O _{8L}	I/O _{0R} -I/O _{8R}	Data Bus Input/Output (I/O ₀ -I/O ₇ for x8 devices; I/O ₀ -I/O ₈ for x9 devices).
OE _L	OE _R	Output Enable Input. This signal must be asserted LOW to enable the I/O data pins during read operations.
R/W _L	R/W _R	Read/Write Enable Input. This signal is asserted LOW to write to the dual-port memory array. For read operations, assert this pin HIGH.
FT/PIPE _L	FT/PIPE _R	Flow-Through/Pipelined Select Input. For flow-through mode operation, assert this pin LOW. For pipelined mode operation, assert this pin HIGH.
GND		Ground Input.
NC		No Connect.
V _{CC}		Power Input.

Maximum Ratings

(Above which the useful life may be impaired. For user guidelines, not tested.)

Storage Temperature -65°C to +150°C
 Ambient Temperature with Power Applied...-55°C to +125°C
 Supply Voltage to Ground Potential -0.5V to +4.6V
 DC Voltage Applied to
 Outputs in High Z State-0.5V to V_{CC}+0.5V
 DC Input Voltage.....-0.5V to V_{CC}+0.5V

Output Current into Outputs (LOW)..... 20 mA
 Static Discharge Voltage >2001V
 Latch-Up Current..... >200 mA

Operating Range

Range	Ambient Temperature	V _{CC}
Commercial	0°C to +70°C	3.3V ± 300 mV
Industrial ^[4]	-40°C to +85°C	3.3V ± 300 mV

Note:

4. Industrial parts are available in CY7C09169AV only.

Electrical Characteristics Over the Operating Range

Parameter	Description	CY7C09159AV CY7C09169AV						Unit
		-9			-12			
		Min.	Typ.	Max.	Min.	Typ.	Max.	
V _{OH}	Output HIGH Voltage (V _{CC} = Min., I _{OH} = -4.0 mA)	2.4			2.4			V
V _{OL}	Output LOW Voltage (V _{CC} = Min., I _{OH} = +4.0 mA)			0.4			0.4	V
V _{IH}	Input HIGH Voltage	2.0			2.0			V
V _{IL}	Input LOW Voltage			0.8			0.8	V
I _{OZ}	Output Leakage Current	-10		10	-10		10	μA
I _{CC}	Operating Current (V _{CC} = Max., I _{OUT} = 0 mA) Outputs Disabled	Com'l.	135	230		115	180	mA
		Ind. ^[4]				155	250	mA
I _{SB1}	Standby Current (Both Ports TTL Level) ^[5] CE _L & CE _R ≥ V _{IH} , f = f _{MAX}	Com'l.	20	75		20	70	mA
		Ind. ^[4]				30	80	mA
I _{SB2}	Standby Current (One Port TTL Level) ^[5] CE _L CE _R ≥ V _{IH} , f = f _{MAX}	Com'l.	95	155		85	140	mA
		Ind. ^[4]				95	150	mA
I _{SB3}	Standby Current (Both Ports CMOS Level) ^[5] CE _L & CE _R ≥ V _{CC} - 0.2V, f = 0	Com'l.	10	500		10	500	μA
		Ind. ^[4]				10	500	μA
I _{SB4}	Standby Current (One Port CMOS Level) ^[5] CE _L CE _R ≥ V _{IH} , f = f _{MAX}	Com'l.	85	115		75	100	mA
		Ind. ^[4]				85	110	mA

Capacitance

Parameter	Description	Test Conditions	Max.	Unit
C _{IN}	Input Capacitance	T _A = 25°C, f = 1 MHz, V _{CC} = 3.3V	10	pF
C _{OUT}	Output Capacitance		10	pF

Note:

5. \overline{CE}_L and \overline{CE}_R are internal signals. To select either the left or right port, both \overline{CE}_0 AND CE₁ must be asserted to their active states ($\overline{CE}_0 \leq V_{IL}$ and CE₁ ≥ V_{IH}).

AC Test Loads

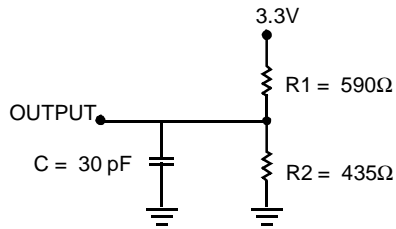

(a) Normal Load (Load 1)

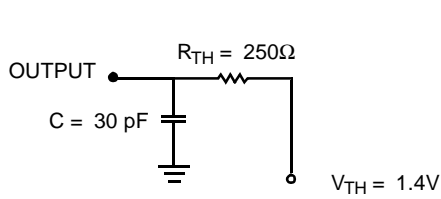

(b) Thévenin Equivalent (Load 1)

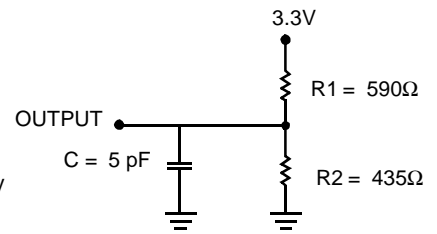

(c) Three-State Delay (Load 2)
 (Used for t_{CKLZ} , t_{OLZ} , & t_{OHZ}
 including scope and jig)

Switching Characteristics Over the Operating Range

Parameter	Description	CY7C09159AV				Unit
		-9		-12		
		Min.	Max.	Min.	Max.	
f_{MAX1}	f_{Max} Flow-Through		40		33	MHz
f_{MAX2}	f_{Max} Pipelined		67		50	MHz
t_{CYC1}	Clock Cycle Time - Flow-Through	25		30		ns
t_{CYC2}	Clock Cycle Time - Pipelined	15		20		ns
t_{CH1}	Clock HIGH Time - Flow-Through	12		12		ns
t_{CL1}	Clock LOW Time - Flow-Through	12		12		ns
t_{CH2}	Clock HIGH Time - Pipelined	6		8		ns
t_{CL2}	Clock LOW Time - Pipelined	6		8		ns
t_R	Clock Rise Time		3		3	ns
t_F	Clock Fall Time		3		3	ns
t_{SA}	Address Set-up Time	4		4		ns
t_{HA}	Address Hold Time	1		1		ns
t_{SC}	Chip Enable Set-up Time	4		4		ns
t_{HC}	Chip Enable Hold Time	1		1		ns
t_{SW}	R/\overline{W} Setup Time	4		4		ns
t_{HW}	R/\overline{W} Hold Time	1		1		ns
t_{SD}	Input Data Set-up Time	4		4		ns
t_{HD}	Input Data Hold Time	1		1		ns
t_{SAD}	\overline{ADS} Set-up Time	4		4		ns
t_{HAD}	\overline{ADS} Hold Time	1		1		ns
t_{SCN}	\overline{CNTEN} Set-up Time	4		4		ns
t_{HCN}	\overline{CNTEN} Hold Time	1		1		ns
t_{SRST}	\overline{CNTRST} Set-up Time	4		4		ns
t_{HRST}	\overline{CNTRST} Hold Time	1		1		ns
t_{OE}	Output Enable to Data Valid		10		12	ns
t_{OLZ}	\overline{OE} to Low Z	2		2		ns
t_{OHZ}	\overline{OE} to High Z	1	7	1	7	ns
t_{CD1}	Clock to Data Valid - Flow-Through		20		25	ns
t_{CD2}	Clock to Data Valid - Pipelined		9		12	ns
t_{DC}	Data Output Hold After Clock HIGH	2		2		ns
t_{CKHZ}	Clock HIGH to Output High Z	2	9	2	9	ns
t_{CKLZ}	Clock HIGH to Output Low Z	2		2		ns
Port to Port Delays						
t_{CWDD}	Write Port Clock High to Read Data Delay		40		40	ns
t_{CCS}	Clock to Clock Set-up Time		15		15	ns

Switching Waveforms

Read Cycle for Flow-Through Output ($\overline{FT}/PIPE = V_{IL}$)^[6, 7, 8, 9]

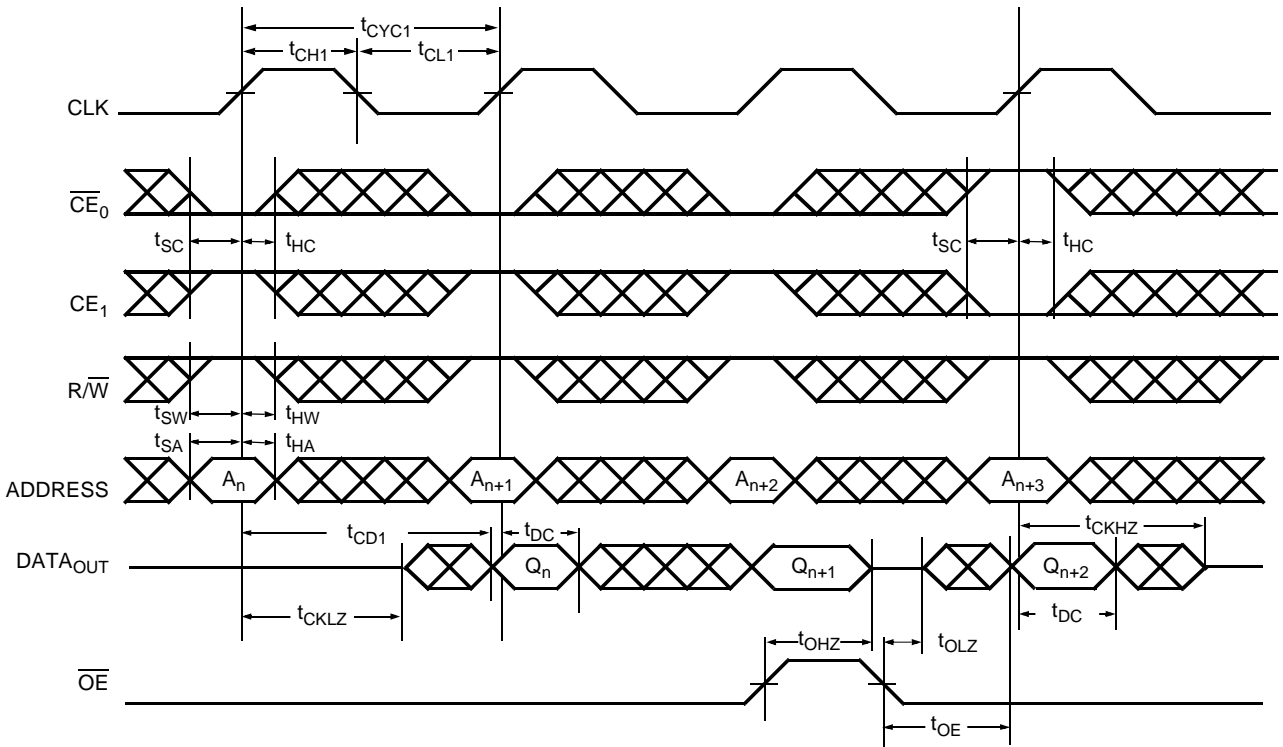

Read Cycle for Pipelined Operation ($\overline{FT}/PIPE = V_{IH}$)^[6, 7, 8, 9]

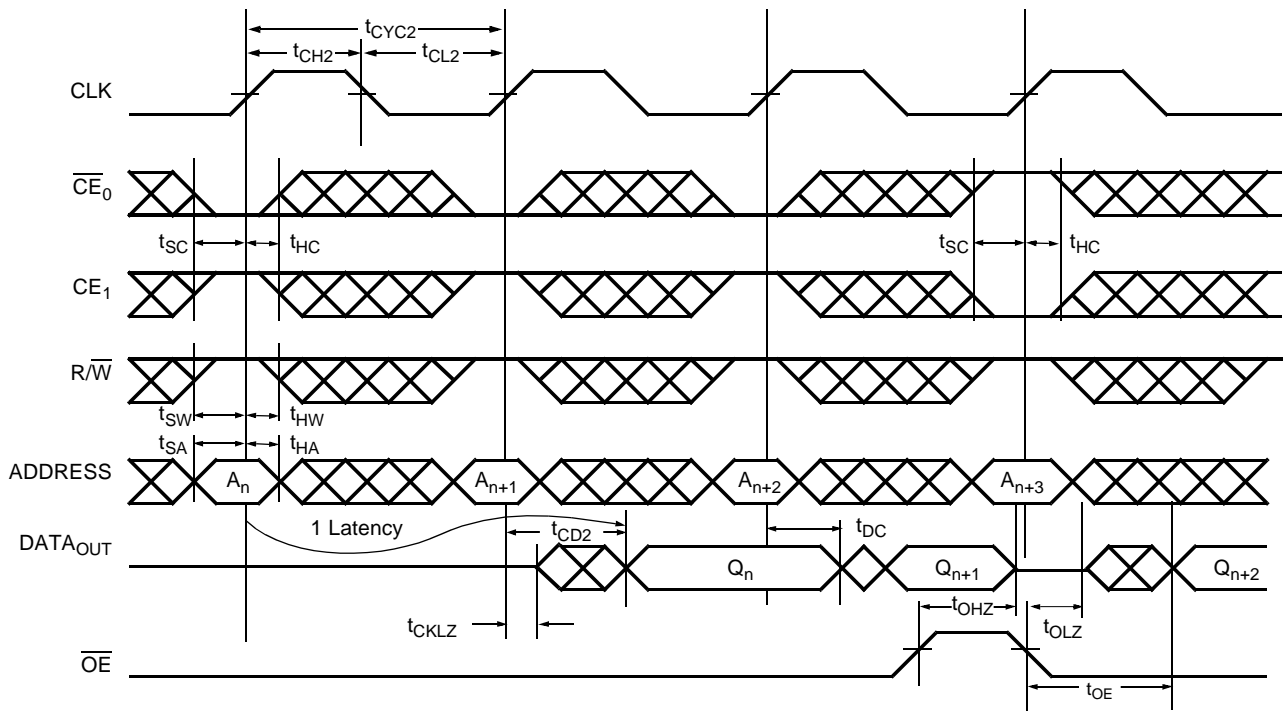

Notes:

6. \overline{OE} is asynchronously controlled; all other inputs are synchronous to the rising clock edge.
7. $ADS = V_{IL}$, $CNTEN$ and $CNTRST = V_{IH}$
8. The output is disabled (high-impedance state) by $\overline{CE}_0 = V_{IH}$ or $CE_1 = V_{IL}$ following the next rising edge of the clock.
9. Addresses do not have to be accessed sequentially since $ADS = V_{IL}$ constantly loads the address on the rising edge of the CLK. Numbers are for reference only.

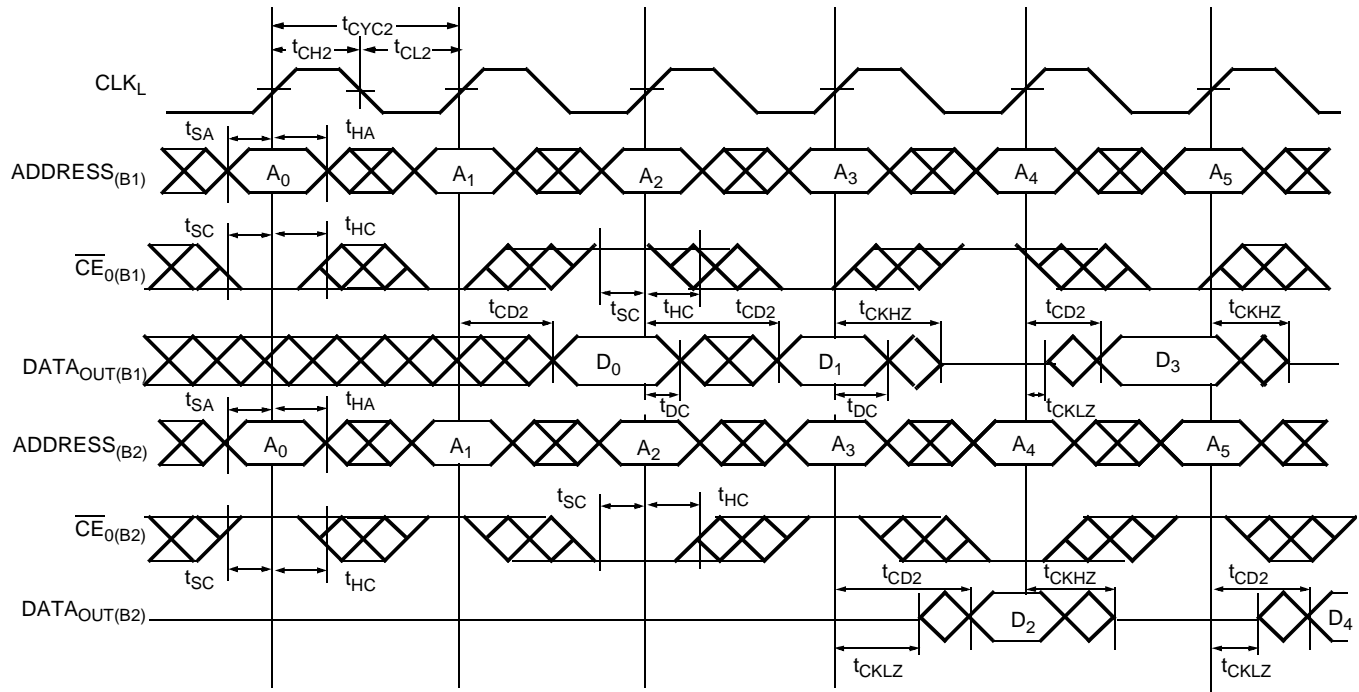
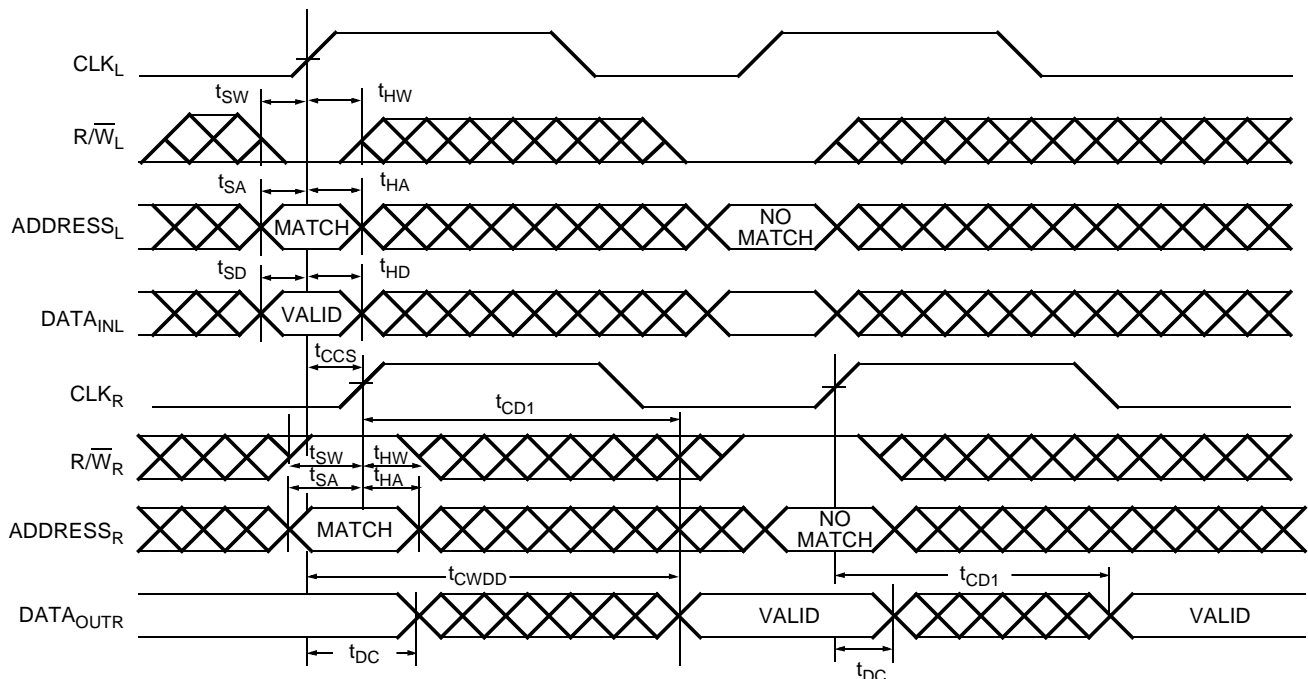
Switching Waveforms (continued)
Bank Select Pipelined Read^[10, 11]

Left Port Write to Flow-Through Right Port Read^[12, 13, 14, 15]

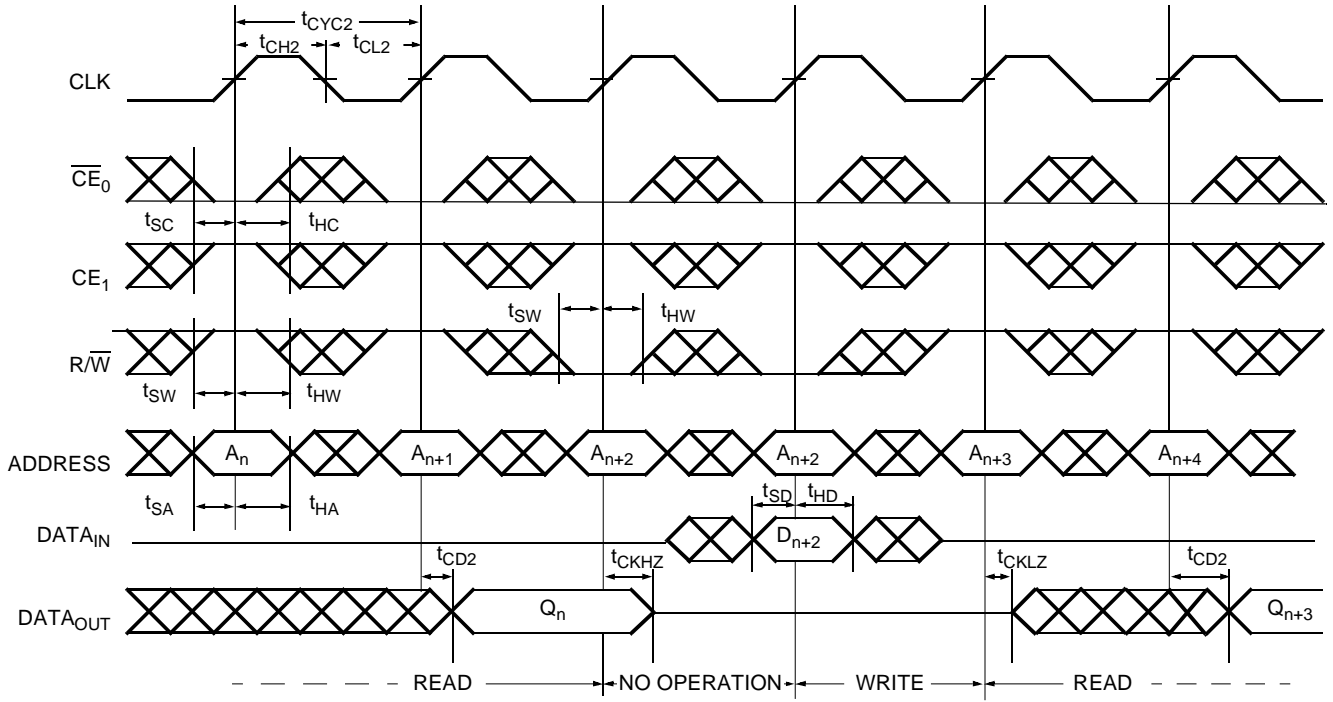
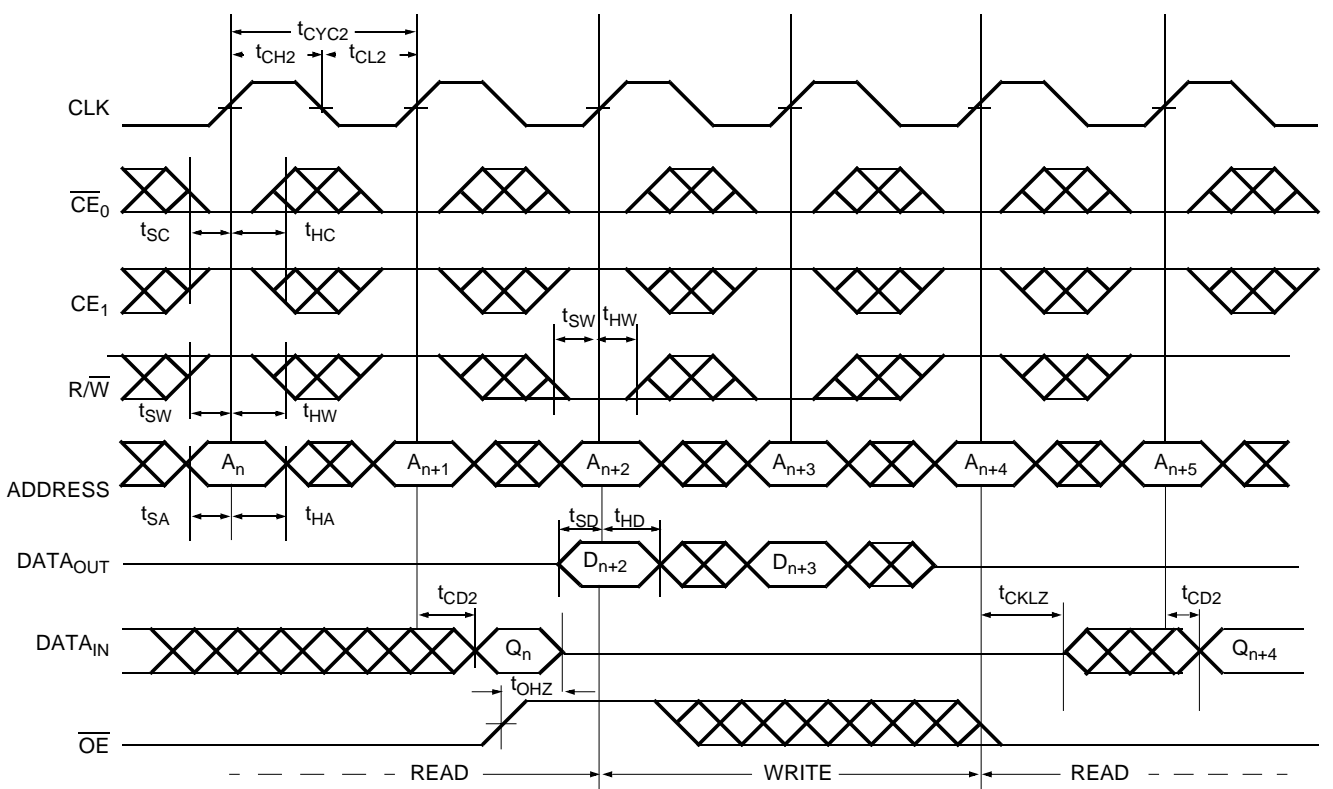
Notes:

10. In this depth expansion example, B1 represents Bank #1 and B2 is Bank #2; Each Bank consists of one Cypress dual-port device from this data sheet. ADDRESS_(B1) = ADDRESS_(B2).
11. OE and ADS = V_{IL}; CE_{1(B1)}, CE_{1(B2)}, R/W, CNTEN, and CNTRST = V_{IH}.
12. The same waveforms apply for a right port write to flow-through left port read.
13. CE₀ and ADS = V_{IL}; CE₁, CNTEN, and CNTRST = V_{IH}.
14. OE = V_{IL} for the right port, which is being read from. OE = V_{IH} for the left port, which is being written to.
15. If t_{CCS} ≤ maximum specified, then data from right port READ is not valid until the maximum specified for t_{CWDD}. If t_{CCS} > maximum specified, then data is not valid until t_{CCS} + t_{CD1}. t_{CWDD} does not apply in this case.

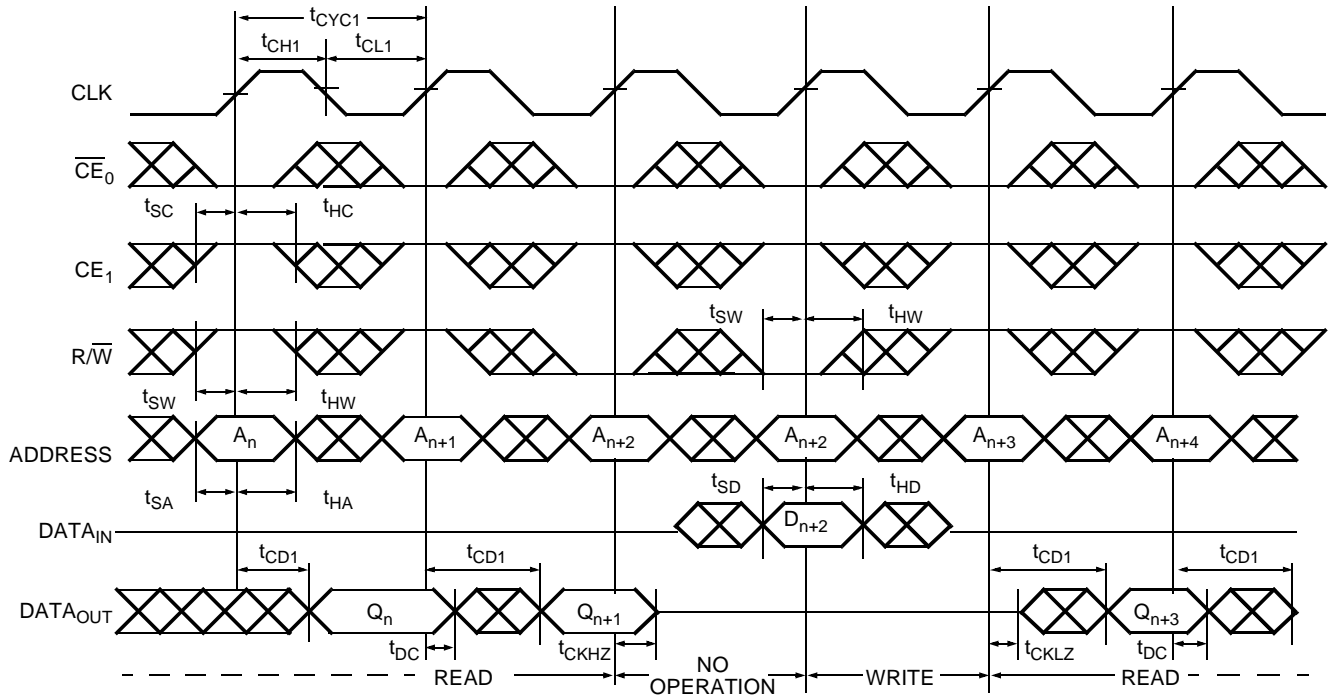
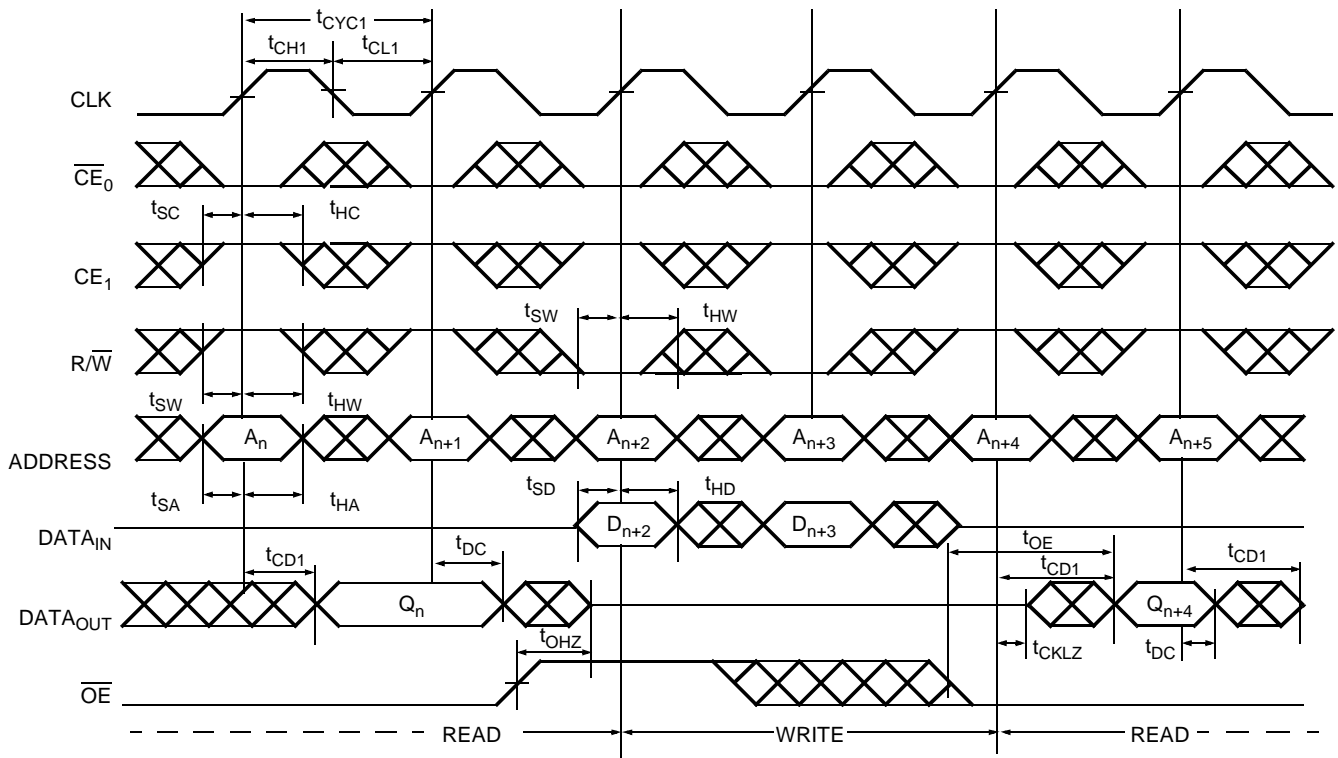
Switching Waveforms (continued)
Pipelined Read-to-Write-to-Read ($\overline{OE} = V_{IL}$)^[9, 16, 17, 18]

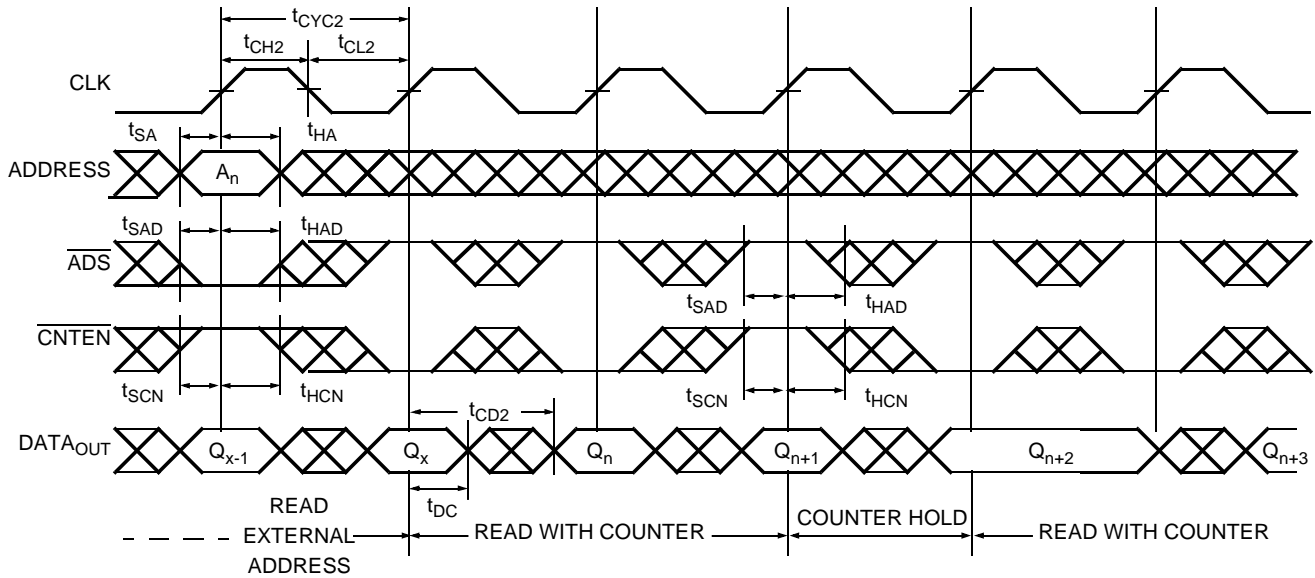
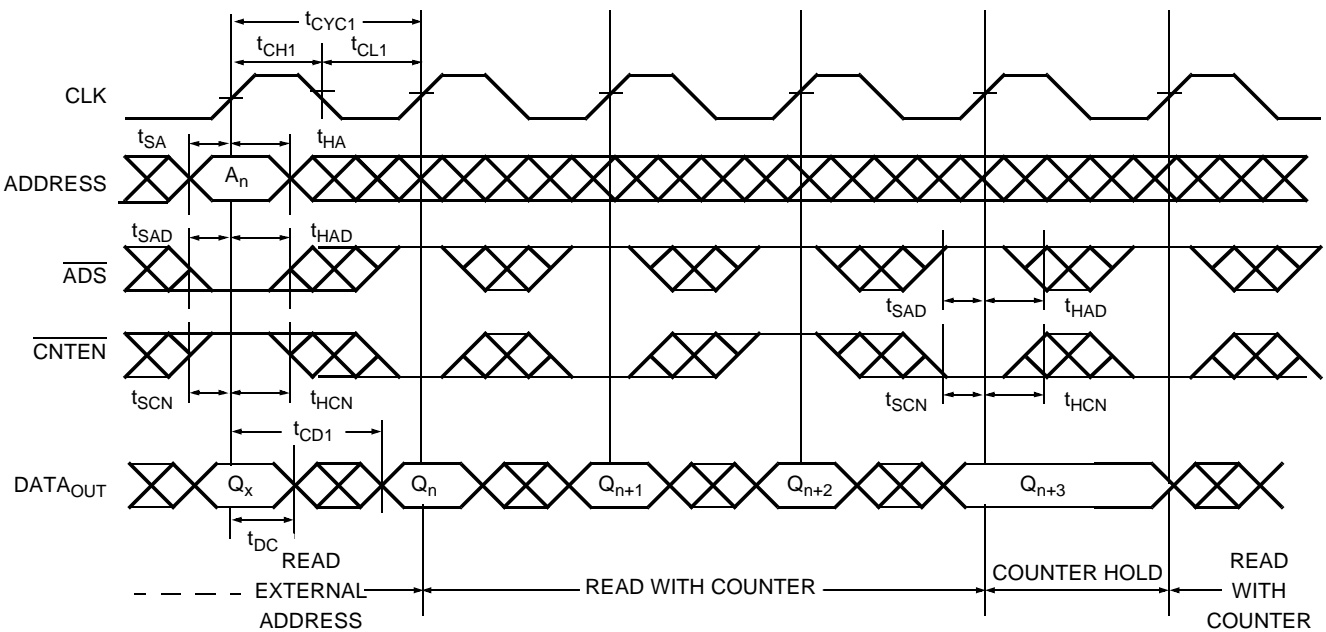
Pipelined Read-to-Write-to-Read (OE Controlled)^[9, 16, 17, 18]

Notes:

16. Output state (HIGH, LOW, or High-Impedance) is determined by the previous cycle control signals.
17. \overline{CE}_0 and $\overline{ADS} = V_{IL}$; \overline{CE}_1 , \overline{CNTEN} , and $\overline{CNTRST} = V_{IH}$.
18. During "No operation," data in memory at the selected address may be corrupted and should be rewritten to ensure data integrity.

Switching Waveforms (continued)
Flow-Through Read-to-Write-to-Read ($\overline{OE} = V_{IL}$) [7, 9, 16, 17, 18]

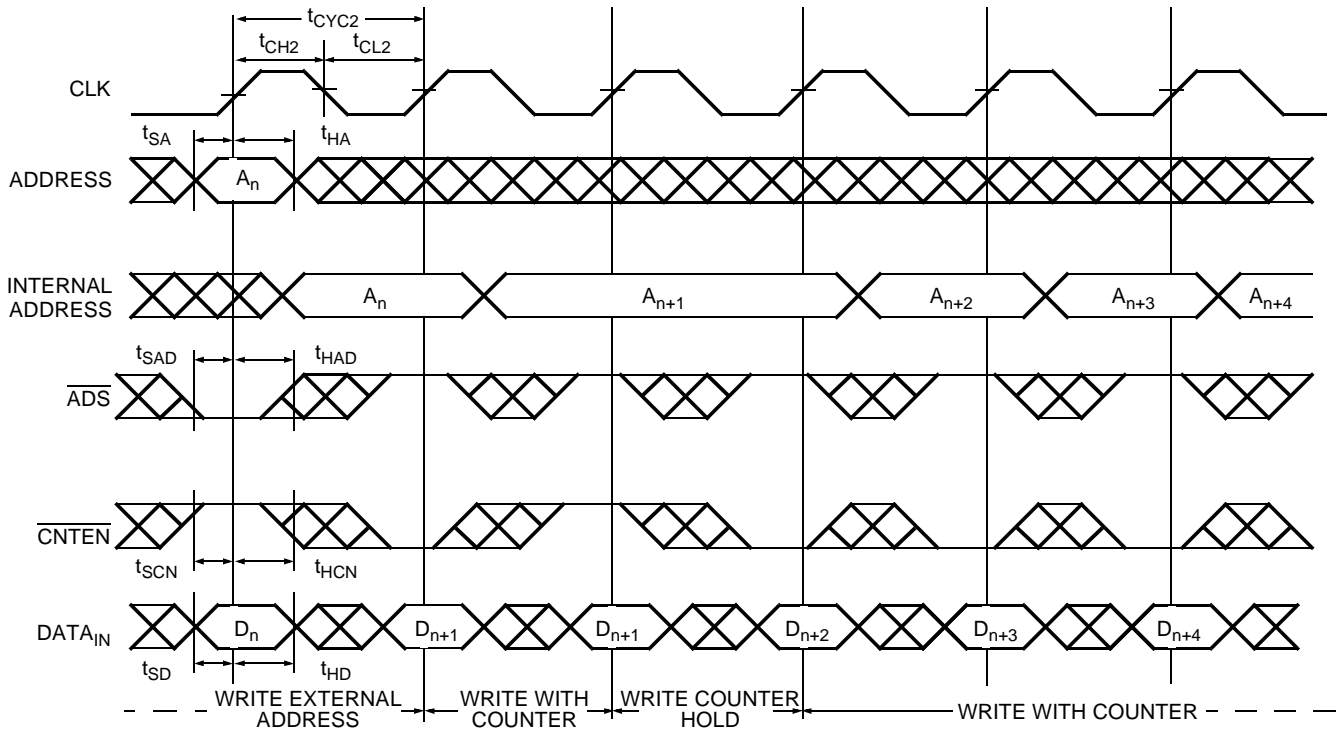
Flow-Through Read-to-Write-to-Read (OE Controlled) [7, 9, 16, 17, 18]

Switching Waveforms (continued)
Pipelined Read with Address Counter Advance^[19]

Flow-Through Read with Address Counter Advance^[19]

Note:

19. \overline{CE}_0 and $\overline{OE} = V_{IL}$; CE_1 , R/\overline{W} and $\overline{CNTRST} = V_{IH}$.

Switching Waveforms (continued)
Write with Address Counter Advance (Flow-Through or Pipelined Outputs)^[20, 21]

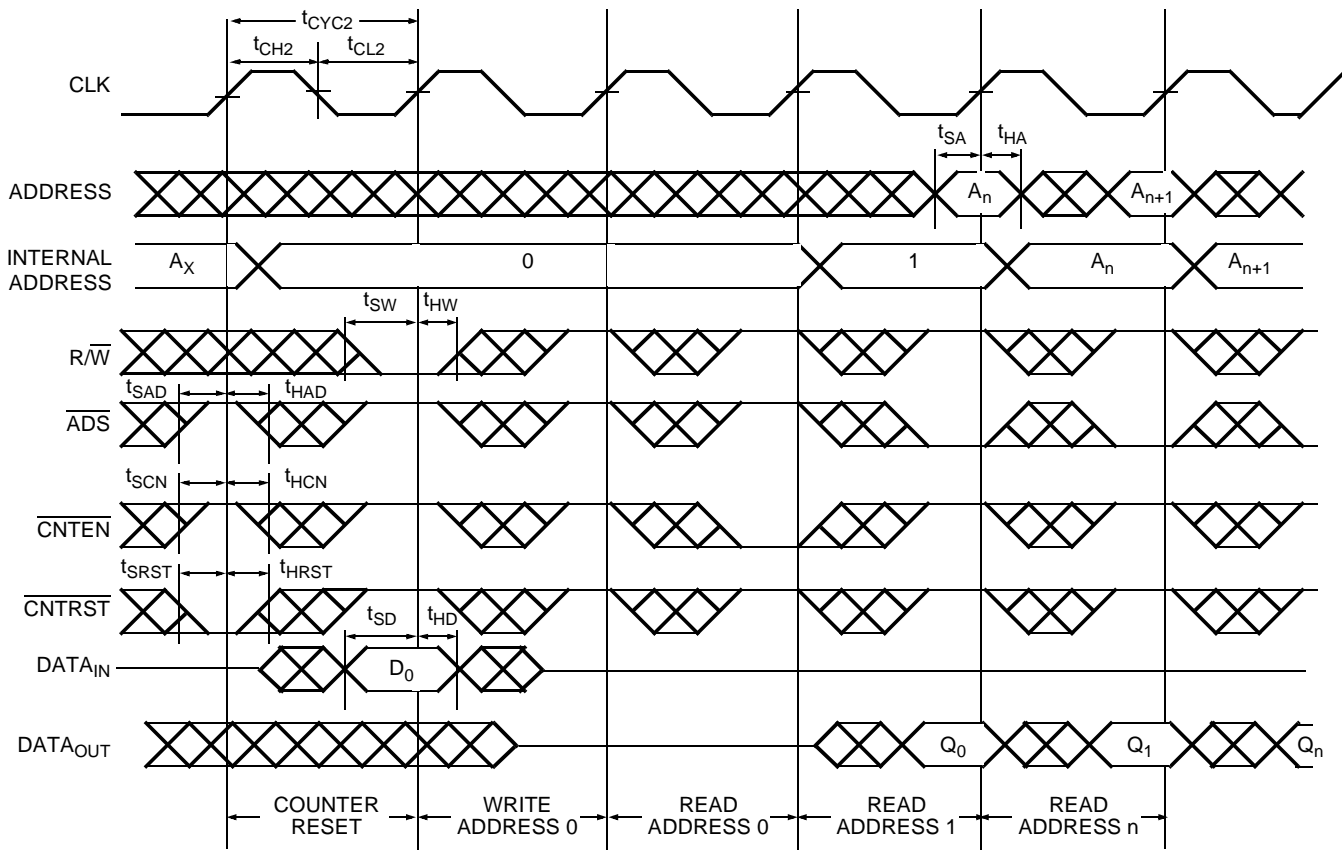
Notes:

20. \overline{CE}_0 and $R/\overline{W} = V_{IL}$; CE_1 and $\overline{CNTRST} = V_{IH}$.





21. The "Internal Address" is equal to the "External Address" when $\overline{ADS} = V_{IL}$ and equals the counter output when $\overline{ADS} = V_{IH}$.

Switching Waveforms (continued)
Counter Reset (Pipelined Outputs)^[9, 16, 22, 23]

Notes:





22. $\overline{CE}_0 = V_{IL}$; $CE_1 = V_{IH}$.

23. No dead cycle exists during counter reset. A READ or WRITE cycle may be coincidental with the counter reset.

Read/Write and Enable Operation^[24, 25, 26]

Inputs					Outputs	Operation
\overline{OE}	CLK	\overline{CE}_0	CE_1	$\overline{R/W}$	$I/O_0-I/O_9$	
X		H	X	X	High-Z	Deselected ^[27]
X		X	L	X	High-Z	Deselected ^[27]
X		L	H	L	D_{IN}	Write
L		L	H	H	D_{OUT}	Read ^[27]
H	X	L	H	X	High-Z	Outputs Disabled

Address Counter Control Operation^[24, 28, 29, 30]

Address	Previous Address	CLK	\overline{ADS}	\overline{CNTEN}	\overline{CNTRST}	I/O	Mode	Operation
X	X		X	X	L	$D_{out(0)}$	Reset	Counter Reset to Address 0
A_n	X		L	X	H	$D_{out(n)}$	Load	Address Load into Counter
X	A_n		H	H	H	$D_{out(n)}$	Hold	External Address Blocked—Counter Disabled
X	A_n		H	L	H	$D_{out(n+1)}$	Increment	Counter Enabled—Internal Address Generation

Notes:

24. "X" = "don't care," "H" = V_{IH} , "L" = V_{IL} .
25. \overline{ADS} , \overline{CNTEN} , \overline{CNTRST} = "don't care."
26. \overline{OE} is an asynchronous input signal.
27. When \overline{CE} changes state in the pipelined mode, deselection and read happen in the following clock cycle.
28. \overline{CE}_0 and \overline{OE} = V_{IL} ; CE_1 and $\overline{R/W}$ = V_{IH} .
29. Data shown for Flow-through mode; pipelined mode output will be delayed by one cycle.
30. Counter operation is independent of \overline{CE}_0 and CE_1 .

Ordering Information
8K x9 3.3V Synchronous Dual-Port SRAM

Speed (ns)	Ordering Code	Package Name	Package Type	Operating Range
9	CY7C09159AV-9AC	A100	100-Pin Thin Quad Flat Pack	Commercial
12	CY7C09159AV-12AC	A100	100-Pin Thin Quad Flat Pack	Commercial

16K x9 3.3V Synchronous Dual-Port SRAM

Speed (ns)	Ordering Code	Package Name	Package Type	Operating Range
9	CY7C09169AV-9AC	A100	100-Pin Thin Quad Flat Pack	Commercial
12	CY7C09169AV-12AC	A100	100-Pin Thin Quad Flat Pack	Commercial
	CY7C09169AV-12AI	A100	100-Pin Thin Quad Flat Pack	Industrial

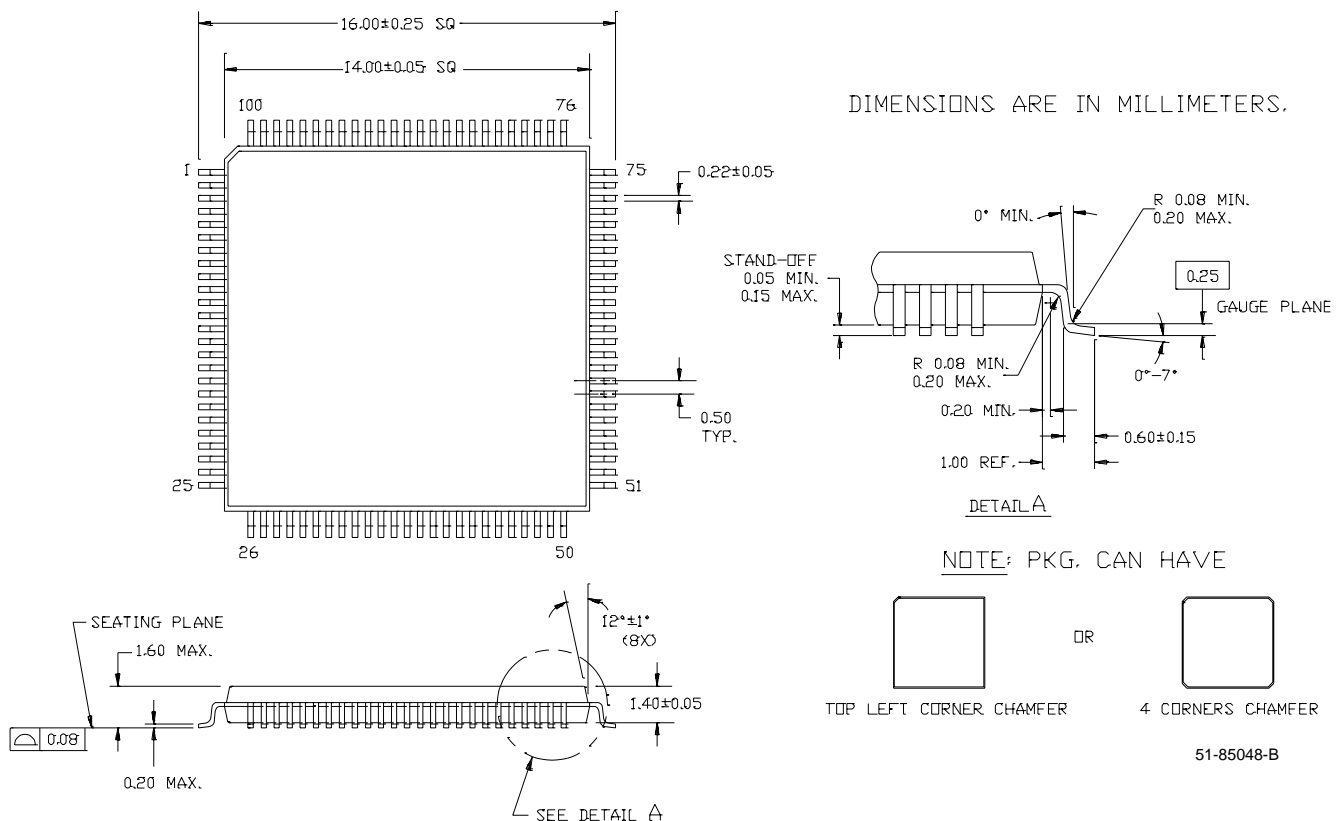
Package Diagram
100-Pin Thin Plastic Quad Flat Pack (TQFP) A100



Document Title: CY7C09159AV/CY7C09169AV 3.3V 8K/16K x 9 Synchronous Dual Port SRAM Document Number: 38-06053				
REV.	ECN NO.	Issue Date	Orig. of Change	Description of Change
**	110205	11/15/01	SZV	Change from Spec number: 38-00839 to 38-06053