

# **AZ DISPLAYS, INC.**

---

*COMPLETE LCD SOLUTIONS*

## **SPECIFICATIONS FOR LIQUID CRYSTAL DISPLAY**

PART NUMBER: □□ □ □ AGM2432B SERIES

DATE: □ □ □ □ □ □ MARCH 30, 2007

# 1. MECHANICAL DATA

(1) Product No.	LTC79_202_52K
(2) Module Size	94.1 (W)mm X 71.5 (H)mm X 7.9 (D)mm
(3) Dot Size	0.225 (W)mm X 0.225 (H)mm
(4) Dot Pitch	0.24 (W)mm X 0.24 (H)mm
(5) Number of Dots	320 (W)Dots X 240 (H) Dots
(6) Duty	1/320
(7) LCD Display Mode	FSTN: <input type="checkbox"/> Gray Mode <input type="checkbox"/> Normally White Rear Polarizer: <input type="checkbox"/> Transflective (Normal) <input type="checkbox"/> Transmissive
(8) Viewing Direction	6 O'clock
(9) Backlight	LED B/L
(10) Weight	57.8 g (Approx.)
(11) Controller	Excluded
(12) DC/DC Converter	Excluded



### 3. ELECTRICAL CHARACTERISTICS

#### 3-1. ELECTRICAL CHARACTERISTICS of LCM

( VDD= 3.3V ± 5% )

ITEM		SYMBOL	CONDITION	MIN.	TYP.	MAX.	UNIT	
Input Voltage		VIH	H level	0.8VDD	—	VDD	V	
		VIO	L level	0	—	0.2VDD	V	
Recommended LC Driving Voltage		VLCD-VSS (Vop)	1/320 Duty 1/16.3 Bias	-20°C	28.6	28.9	29.2	V
				0°C	27.2	27.5	27.8	
				25°C	26.4	26.7	27.0	
				50°C	25.4	25.7	26.0	
				70°C	24.8	25.1	25.4	
Power Supply Current		IDD	VDD=3.3V VSS=0V VLCD-VSS=26.7V FLM=70Hz PATTERN: □ ■ □ ■ □ ■	—	0.1	0.2	mA	
		IEE	■ □ ■ □ ■ □	—	3.0	4.5		
LCM	Surface Luminance (S202J)	L	VDD= 3.3V VSS= 0V VLCD-VSS=26.7V ILED=55mA	PATTERN: (Dots All On) ■ ■ ■ ■ ■ ■ ■ ■	—	2.4	—	cd/m <sup>2</sup>
				PATTERN: (Dots All Off) □ □ □ □ □ □ □ □	—	7.2	—	

### 3-2.ELECTRICAL CHARACTERISTICS OF BACKLIGHT

Used LED Rating

Temp.=25°C

ITEM	SYMBOL	MIN.	TYP.	MAX.	UNIT	REMARK
Peak forward current	I <sub>P</sub>	—	—	100	mA	—
Maximum reverse voltage	V <sub>R</sub>	—	—	5	V	—
Applied forward current	I <sub>F</sub>	—	55	—	mA	at V <sub>F</sub> = 3.5 V
Applied forward voltage	V <sub>F</sub>	—	3.5	—	V	at I <sub>F</sub> = 55 mA
LED power consumption	P <sub>F</sub>	—	0.2	—	W	—
LED life time	L <sub>L</sub>	—	10000	—	hrs	at I <sub>F</sub> = 55 mA (*1)
AVG. X of 1931 C.I.E.	X	0.287	0.32	0.36	—	—
AVG. Y of 1931 C.I.E.	Y	0.276	0.32	0.36	—	—

(\*1) LED life time is defined as follows : The final brightness is at 50% of original brightness.

## 4. OPTICAL CHARACTERISTICS

AT Vop

ITEM MODE		Cr(Contrast Ratio)										$\theta$ (Viewing Angle)		$\phi$ (Viewing Angle)	
		-20℃		0℃		25℃		50℃		75℃		25℃		25℃	
		MIN.	TYP.	MIN.	TYP.	MIN.	TYP.	MIN.	TYP.	MIN.	TYP.	MIN.	TYP.	MIN.	TYP.
S	J	4.0	4.5	5.5	6.0	5.5	6.0	4.5	5.0	3.0	3.5	-	64	-	(L) 34 (R) 37
T	A	2.0	2.5	2.5	3.0	2.5	3.0	2.0	2.5	1.5	2.0	-	43	-	±22
T	J	3.5	4.0	4.0	4.5	4.0	4.5	3.0	3.5	2.0	2.5	-	66	-	±30
Note		NOTE 6										NOTE 5			

NOTE :

S: TRANSLUCTIVE(NORMAL)

A: GRAY,6 O'CLOCK

T: TRANSMISSIVE

J: NORMALLY WHITE,6 O'CLOCK

AT  $\phi=0^\circ$   $\theta=0^\circ$

ITEM	SYMBOL	CONDITION	MIN.	TYP.	MAX.	UNIT	NOTE
Response Time (rise)	Tr	-20℃	3500	5000	7000	ms	NOTE 2
		0℃	700	1000	1500		
		25℃	180	260	390		
		50℃	90	130	200		
		70℃	70	100	150		
Response Time (fall)	Tf	-20℃	2000	3000	4500	ms	NOTE 2
		0℃	350	500	750		
		25℃	120	170	250		
		50℃	50	70	100		
		70℃	35	50	75		

(NOTE 1)

Definition of Operation Voltage(Vop)

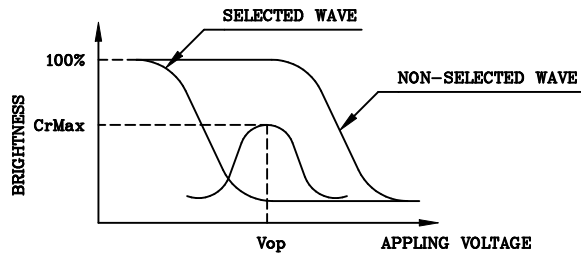

(positive type)

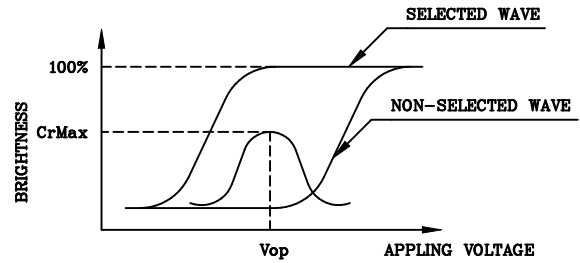

(negative type)

\*Conditions

- Viewing Angle : 0
- Frame Frequency : 70Hz
- Applying Waveform : 1/N duty 1/a bias

(NOTE 2)

Definition of Response Time(Tr,Tf)

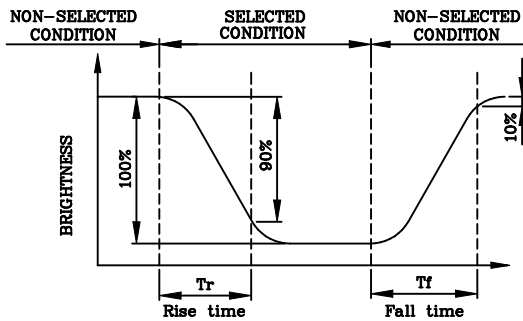

(positive type)

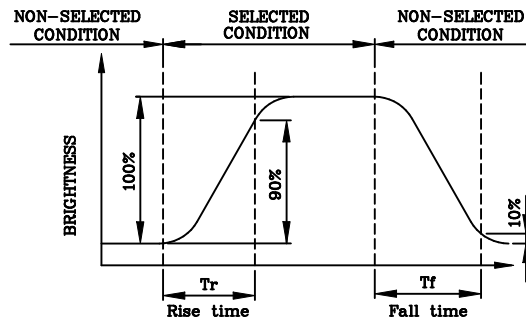

(negative type)

\*Conditions

- Operating Voltage : Vop
- Viewing Angle (θ,φ) : (0,0)
- Frame Frequency : 70Hz
- Applying Waveform : 1/N duty 1/a bias

(NOTE 3)

Description of Measuring Equipment and Driving Waveforms

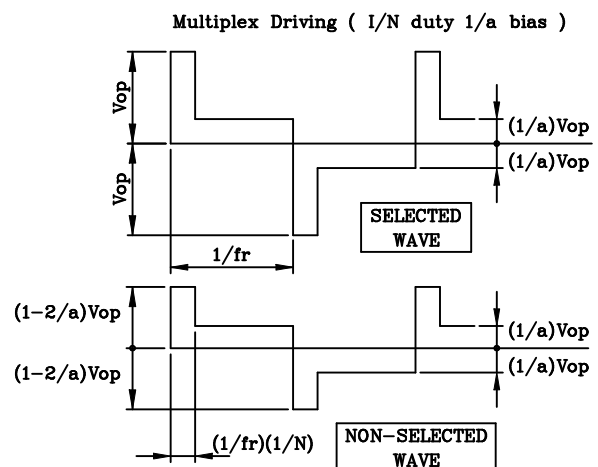
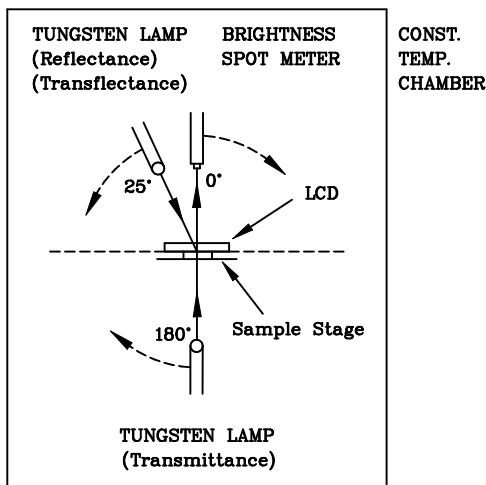

(NOTE 4)

Definition of Viewing Direction

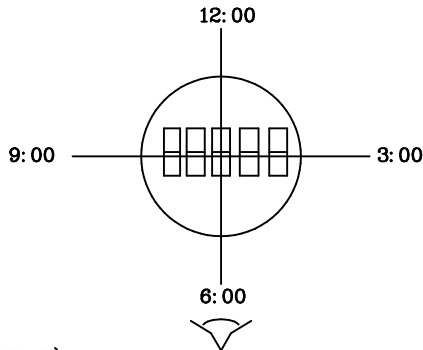

(NOTE 5)

Definition of Viewing Angle

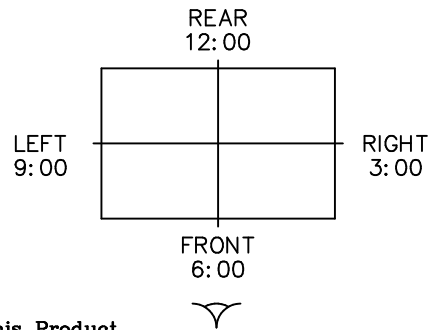
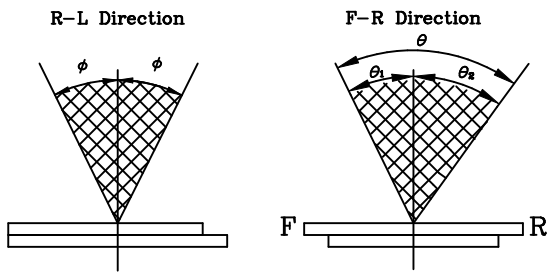

\*For This Product  
The Viewing Direction Is 6 O'clock  
So  $\theta_1 > \theta_2$

$$\theta = \theta_1 + \theta_2$$

\*Conditions

- Operating Voltage :  $V_{op}$
- Frame Frequency : 70Hz
- Applying Waveform : 1/N duty 1/a bias
- Contrast Ratio : larger than 2

(NOTE 6)

Definition of Contrast Ratio (Cr)

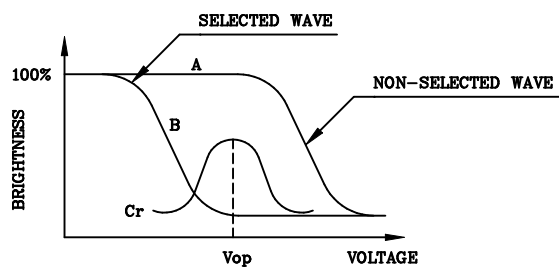

(positive type)

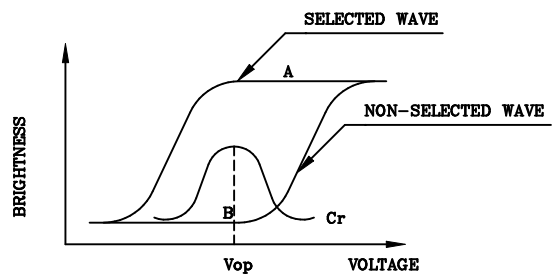

(negative type)

$$\text{Contrast Ratio : } Cr = A/B$$

\*Conditions

- Viewing Angle : 0
- Frame Frequency : 70Hz
- Applying Waveform : 1/N duty 1/a bias



# 5. BLOCK DIAGRAM

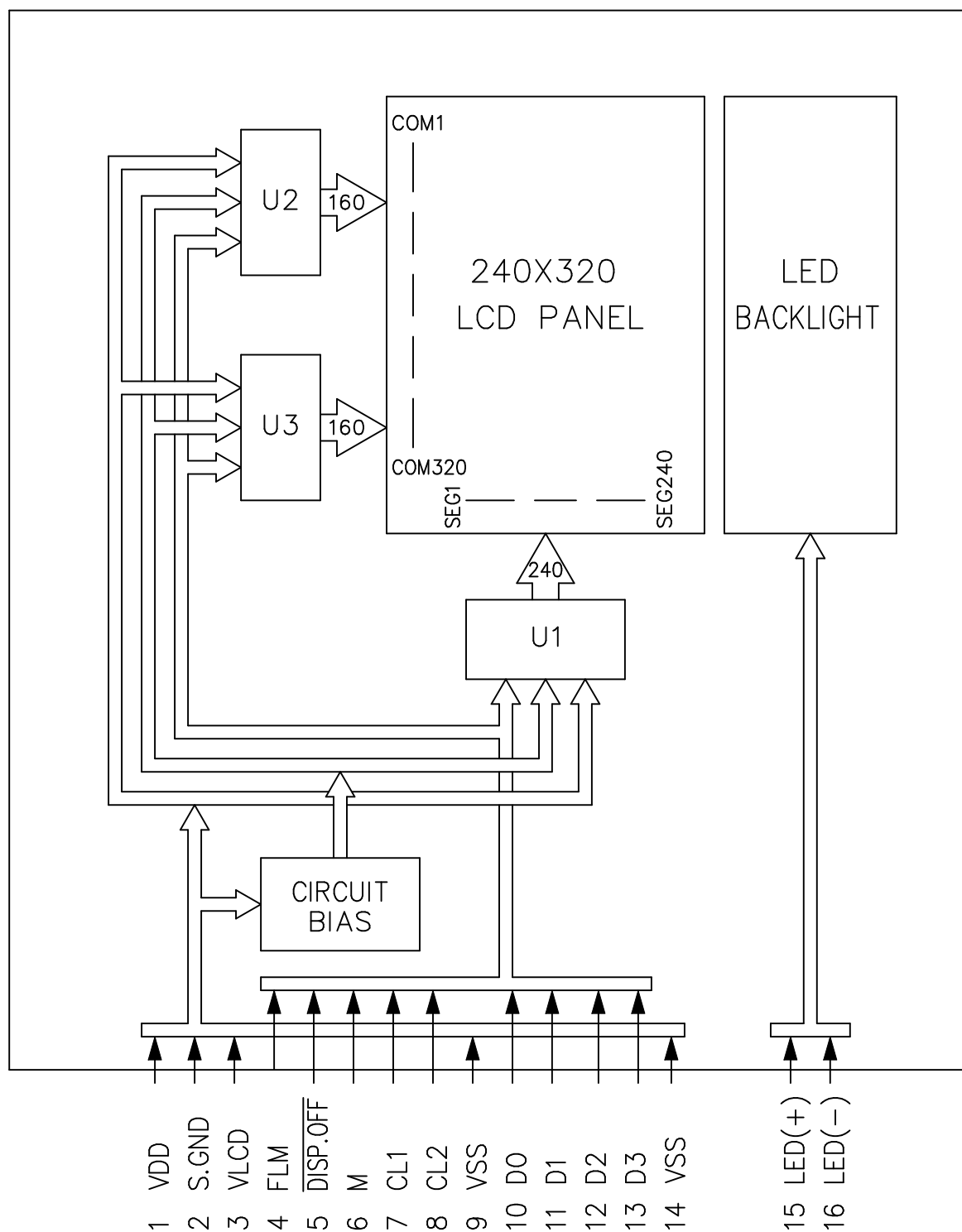

## 6. INTERNAL PIN CONNECTION

FPC ,20 pins,pitch 0.5mm

Pin No.	Symbol	Function
1	VDD	POWER SUPPLY FOR LOGIC
2	S.GND	SHIELD GROUND
3	VLCD	POWER SUPPLY FOR LCD
4	FLM	FIRST LINE MARKER
5	$\overline{\text{DISP.OFF}}$	H: ON/L: OFF
6	M	SWITCH SIGNAL TO CONVERT LIQUID CRYSTAL DRIVE WAVEFORM INTO AC
7	CL1	DATA LATCH
8	CL2	SHIFT CLOCK
9	VSS	LOGIC GROUND
10	D0	DISPLAY DATA
11	D1	DISPLAY DATA
12	D2	DISPLAY DATA
13	D3	DISPLAY DATA
14	VSS	LOGIC GROUND
15	LED(+)	POWER SUPPLY FOR LED
16	LED(-)	POWER SUPPLY FOR LED
17	NC	NC
18	NC	NC
19	NC	NC
20	NC	NC

Mating Connector: MOLEX 52746-2090

# 7. POWER SUPPLY

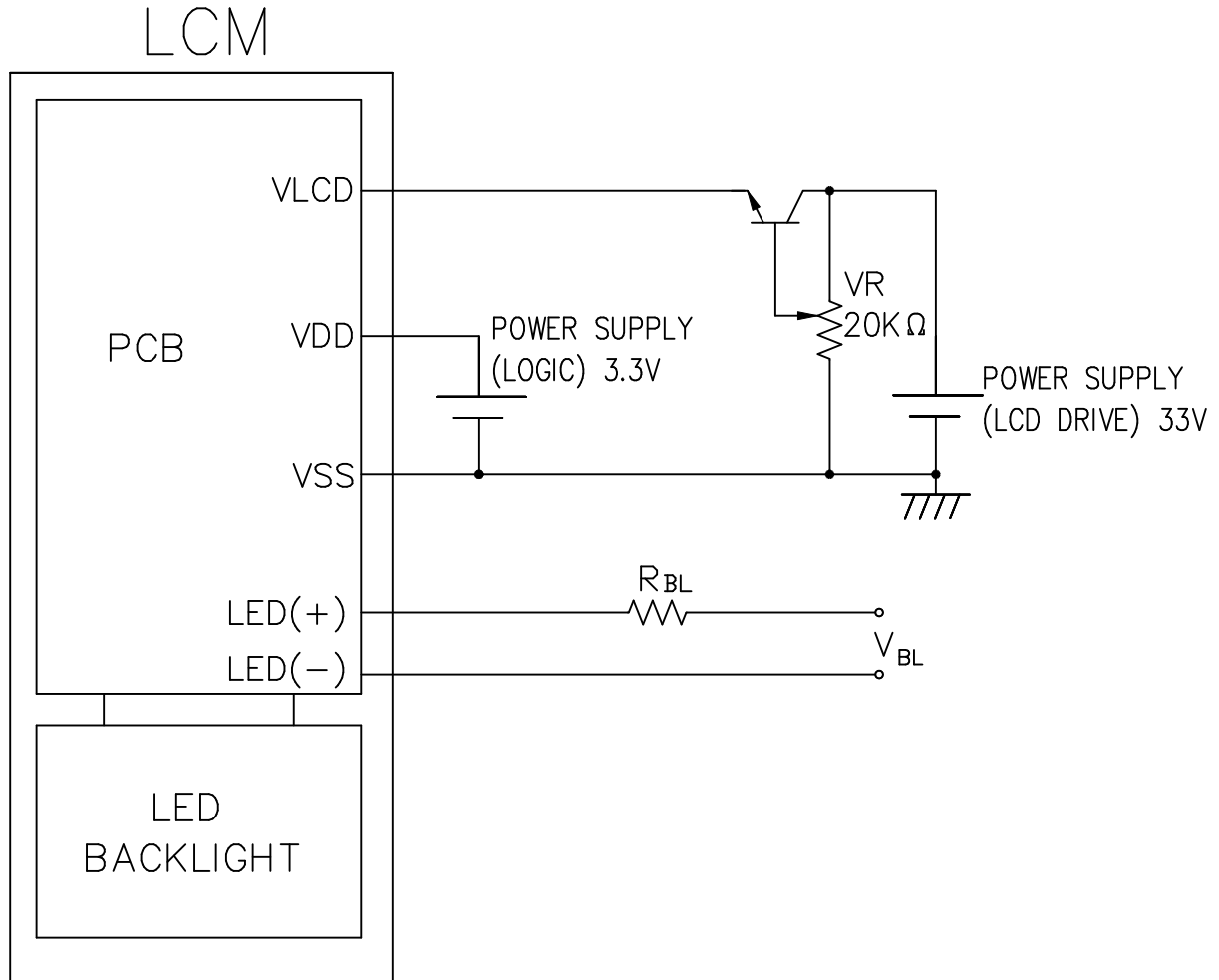

Recommended Value for R<sub>BL</sub> & V<sub>BL</sub>

item	R <sub>BL</sub>	V <sub>BL</sub>
Back Light interface	White LED	White LED
LED(+),LED(-) PIN	33Ω	5 Vdc

# 8. TIMING CHARACTERISTICS

## 8-1. INTERFACE TIMING

@ VDD=3.0V±5%, Ta=-20~85 °C

Item	Symbol	Test condition	Min.	Typ.	Max.	Unit
CL2 Cycle Time	t <sub>C</sub>	Fig.a	125	-	-	ns
CL2 Pulse Width	t <sub>SWH</sub> ,t <sub>SWL</sub>	Fig.a	51	-	-	ns
CL2 Rise/Fall Time	t <sub>CR</sub> ,t <sub>CF</sub>	Fig.a	-	-	50	ns
Data Set Up Time	t <sub>DSU</sub>	Fig.a	30	-	-	ns
Data Hold Time	t <sub>DHD</sub>	Fig.a	40	-	-	ns
CL1 Cycle Time	t <sub>L</sub>	Fig.b	250	-	-	ns
CL1 "H" Pulse Width	t <sub>LWH</sub>	Fig.a , Fig.b	51	-	-	ns
CL1 Rise/Fall Time	t <sub>LR</sub> ,t <sub>LF</sub>	Fig.b	-	-	50	ns
CL2 To CL1 Delay Time	t <sub>CL</sub>	Fig.a	51	-	-	ns
CL1 To CL2 Delay Time	t <sub>LC</sub>	Fig.a	51	-	-	ns
FLM TO CL1 SETUP TIME	t <sub>FLS</sub>	Fig.b	30	-	-	ns
FLM TO CL1 HOLD TIME	t <sub>FLH</sub>	Fig.b	50	-	-	ns

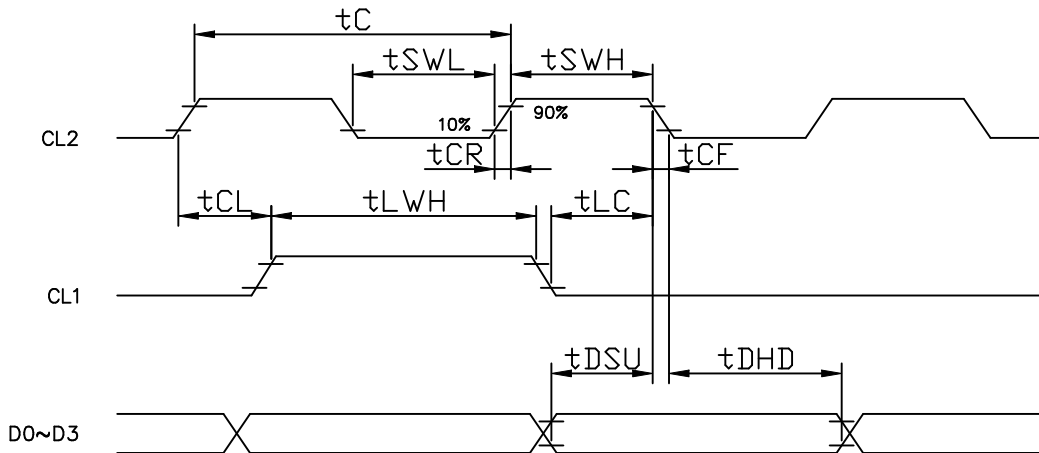

Fig . a Interface timing (SEGMENT)

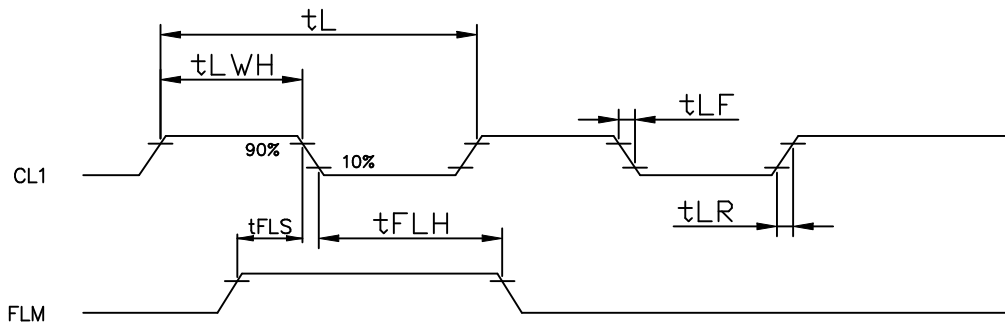
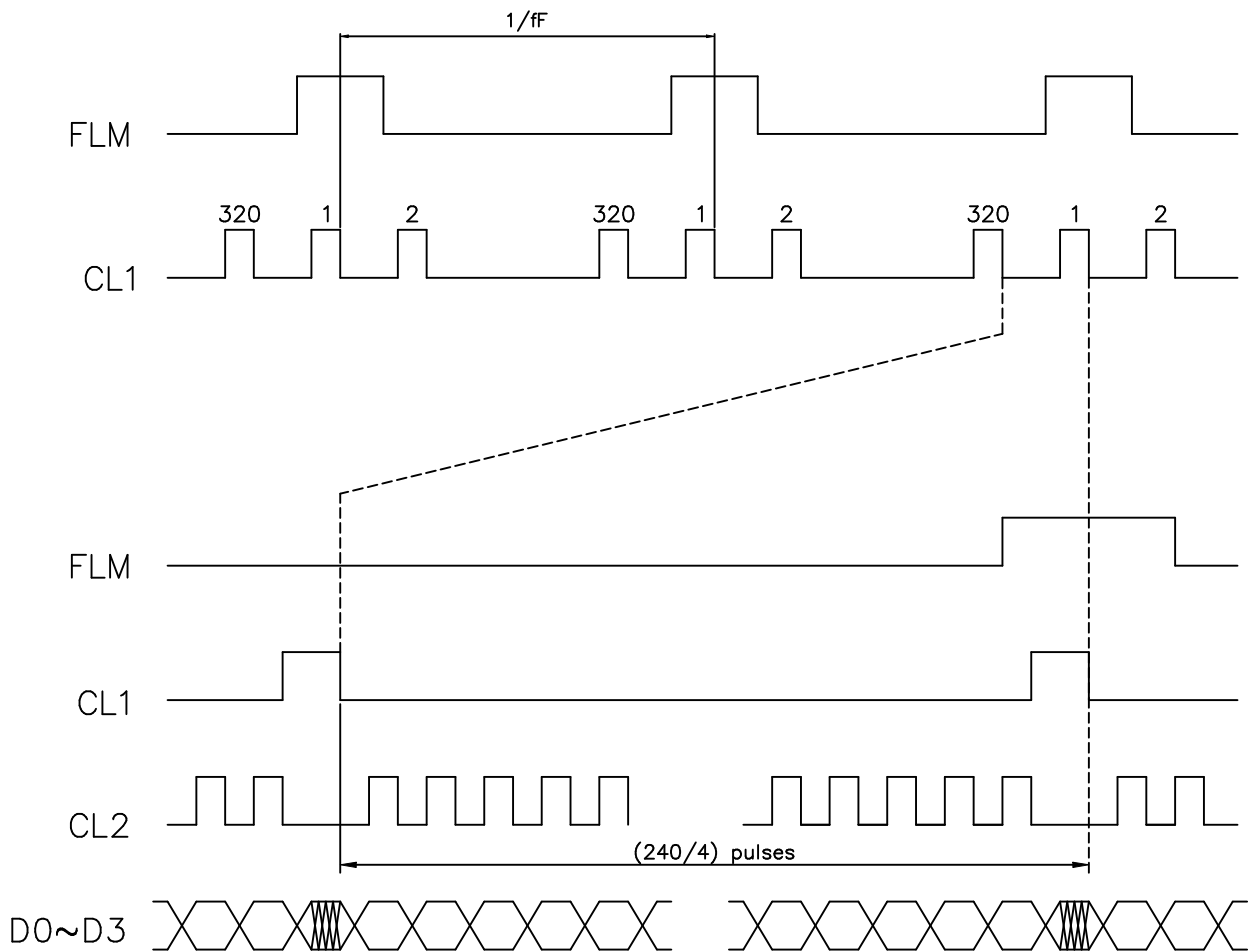
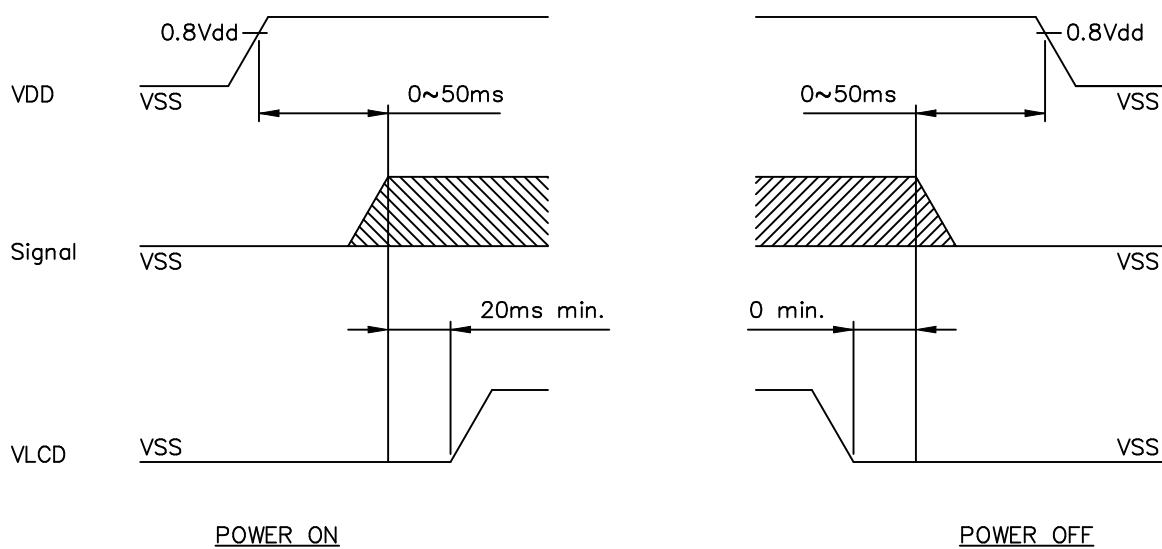

Fig . b Interface timing (COMMON)

## 8-2. TIMING CHART OF INPUT SIGNAL



## 8-3. POWER ON/OFF TIMING



The missing pixels may occur when the LCM is driven beyond above power interface timing sequence.



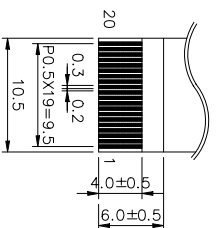
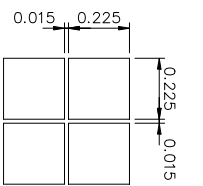
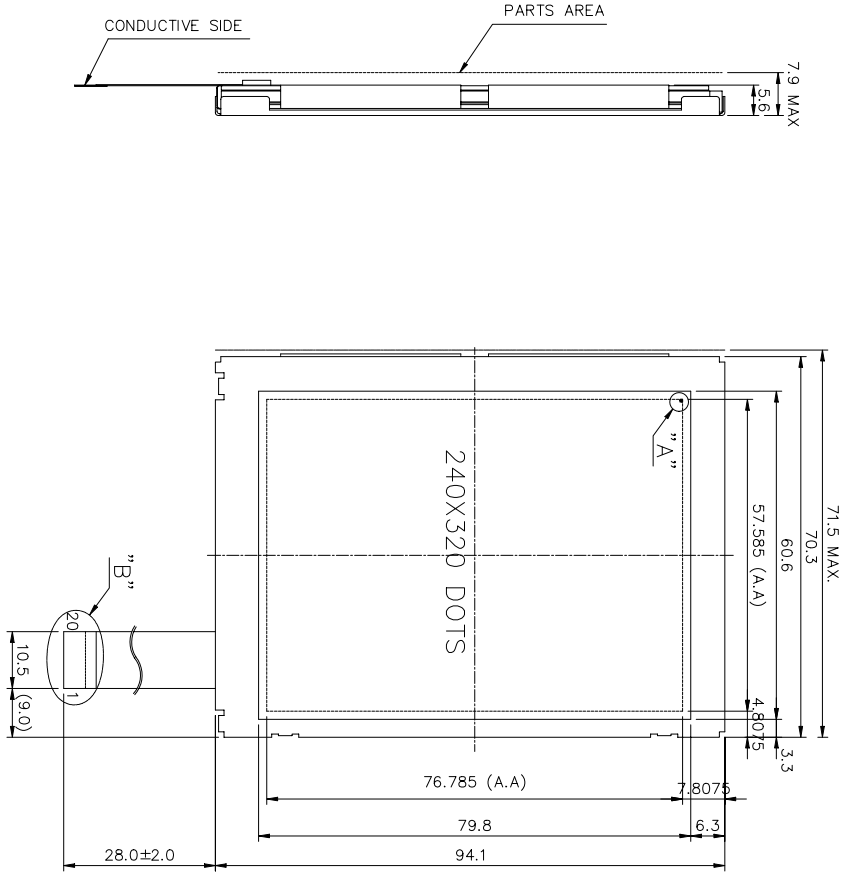
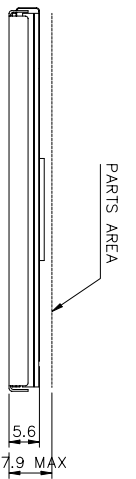

FIRST DATA

	Seg 1	Seg 2	Seg 3	Seg 4	Seg 240
Com 1	1.1	1.2	1.3	1.4	1.240
Com 2	2.1	2.2	2.3		
Com 3	3.1	3.2			

D0: (1.4),(1.8).....(320,240)  
 D1: (1.3),(1.7).....(320,239)  
 D2: (1.2),(1.6).....(320,238)  
 D3: (1.1),(1.5).....(320,237)

Com 320 320.1 ..... 320.240

NOTES:

- 1.RESOLUTION: 240X320 DOTS
- 2.BACKLIGHT: LED (WHITE)
- 3.FRAME MATERIAL: SECC
- 4.GLASS THICKNESS: 0.7 mm

PIN NO	SYMBOL	LEVEL	FUNCTION	PIN NO	SYMBOL	LEVEL	FUNCTION
1	VDD	H	POWER SUPPLY FOR LOGIC	10	DO		
2	S.GND	-	SHIELD GROUND	11	D1	H/L	DISPLAY DATA
3	VLCD	H	POWER SUPPLY FOR LCD	12	D2		
4	FLM	H	FIRST LINE MARKER	13	D3		
5	DISP.OFF	H/L	H.ON/L.OFF	14	VSS	-	LOGIC GROUND
6	M	H/L	SWITCH SIGNAL TO CONVERT LIQUID CRYSTAL DRIVE WAVEFORM INTO AC	15	LED(+)	-	POWER SUPPLY FOR LED
7	CL1	H/L	DATA LATCH	16	LED(-)	-	POWER SUPPLY FOR LED
8	CL2	H/L	SHIFT CLOCK	17			
9	VSS	-	LOGIC GROUND	18	NC		
				19			
				20			

REV. NO.	DESCRIPTION	DATE	DESIGN	CHECK	APPROVE

APPROVE	DATE	THIRD ANGLE P
CHECK	89.12.19	SCALE UNIT
DRAWN	C. B. Ian 89.12.19	1/1 mm

GENERAL TOLERANCE LIST

DIMENSION	TOLERANCE
L ≤ 6	±0.25 (mm)
6 < L ≤ 18	±0.3 (mm)
18 < L ≤ 50	±0.4 (mm)
50 < L ≤ 125	±0.5 (mm)
125 < L	±0.6 (mm)
ANGLE	±1° (DEG)

**AZ DISPLAYS, INC.**  
**AGM2432B Series**