

Features

- Resolution: 12-Bit ± 0.5 LSB(DNL)
- Maximum Conversion Rate: 6 MSPS
- Built-in Sample and Hold Function
- Built-in Reference Voltage
- Single +5.0 V Power Supply
- Three-State TTL Compatible Output
- No Missing Code

Applications

- Video Digitizing
- Personal Computer Video
- Multimedia
- Digital Television

General Description

The AT2101 is a pipeline CMOS analog-to-digital converter with modified coding algorithm and capable of digitizing full-scale analog input signals into 12-bit digital words at sample rate of 6 MSPS.

This high performance converter includes a 12-bit quantizer, high bandwidth sample/hold, and an internal reference, which eliminates the need for external reference circuitry. The AT2101 employs digital error correction techniques to provide excellent differential linearity for imaging applications.

The AT2101 operates from a single +5.0V power supply. All digital inputs are CMOS compatible and the tri-state outputs are TTL-compatible. The AT2101 is ideal for most video and image processing applications that require low power dissipation and low cost.

Block Diagram

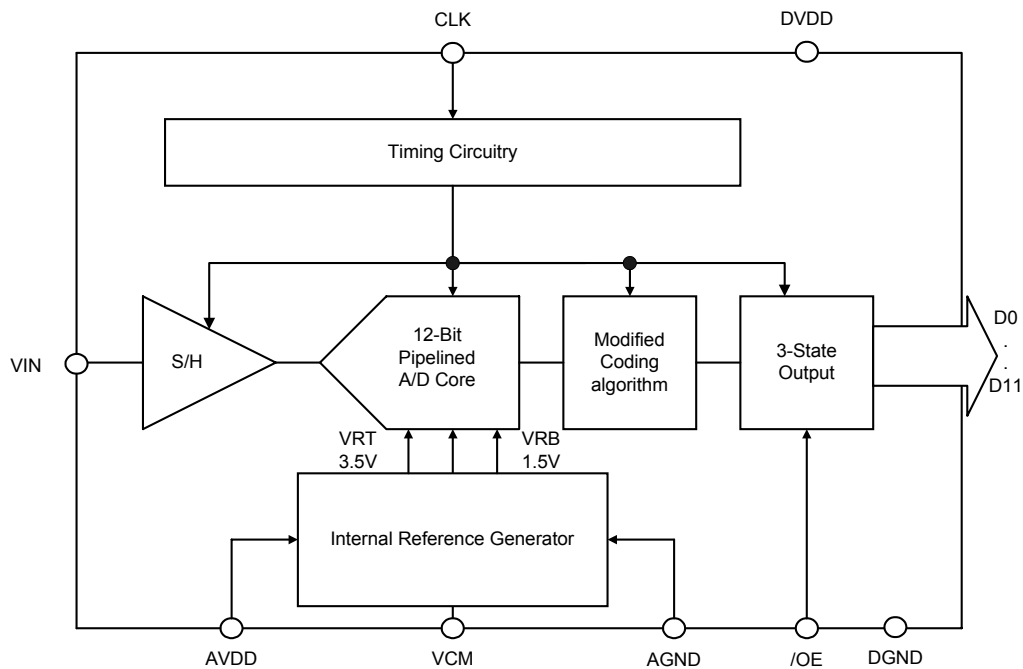

Pin Configuration

AT2101 (28-Pin 300 mil SOP)

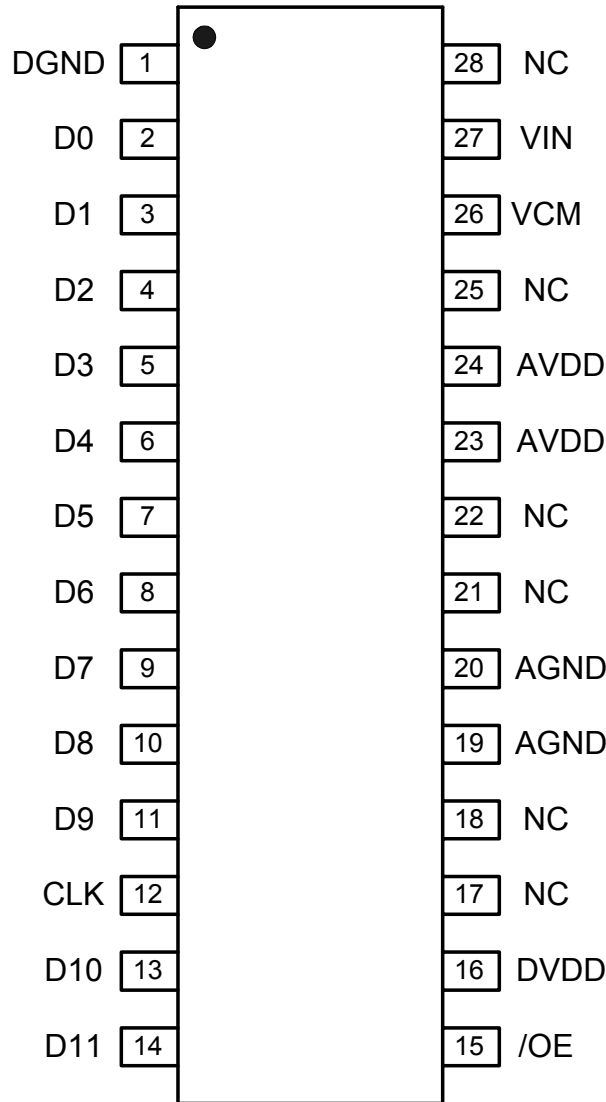

Pin Description

PIN	NAME	FUNCTION	PIN	NAME	FUNCTION
16	DVDD	Digital +5V Supply	23 24	AVDD	Analog +5V Supply
1	DGND	Digital GND	19 20	AGND	Analog GND
2~11	D0~D9	Digital Output Data D0 (LSB) ~D9	13 14	D10 D11	Digital Output Data D10 (MSB) ~D11
15	\overline{OE}	Output Enable Control D0~D11 Output Enabled When \overline{OE} = Low D0~D11 at High Impedance When \overline{OE} = High	26	VCM	Common-Mode Voltage Output
12	CLK	Clock Input	27	VIN	Analog Input
17,18 21,22 25,28	NC				

Absolute Maximum Ratings (Beyond which damage may occur) 25°C
Supply Voltages
 V_{DD} -0.5 to +7.0 V

Input Voltages

 Analog InputAGND to V_{DD}

 Reference Input VoltageAGND to V_{DD}

ESD Susceptibility± 1,500V

Temperature

Operating Temperature-20 to +70°C

Junction Temperature175°C

Lead Temperature, (Soldering 10 seconds)300°C

Storage Temperature-55 to +125°C

2F, No.10, Prosperity RD. II, Science-Based Industrial Park, Hsinchu 300, Taiwan, R.O.C.

Tel: 886-3-563-0878

Fax: 886-3-563-0879

 WWW: <http://www.aimtron.com.tw>

 Email: service@aimtron.com.tw

Electrical Specifications
 $T_a = +25^{\circ}\text{C}$, $AV_{DD} = DV_{DD} = +5.0\text{V}$, $AGND = DGND = 0.0\text{V}$, $V_{RB} = 1\text{V}$ and $V_{RT} = 3\text{V}$, unless otherwise specified.

PARAMETERS	TEST CONDUCTION	MIN	TYP	MAX	UNITS
Resolution		12			Bits
DC Accuracy (+25°C)					
Integral Nonlinearity			± 1.5		LSB
Differential Nonlinearity			± 0.5		LSB
No Missing Codes			Guaranteed		
Zero Error(+25°C)				± 7.5	%FSR
Gain Error(+25°C)				± 1.25	%FSR
Analog Input					
Input Voltage Range		1.5		3.5	V
Common-Mode Voltage			2.5		V
Input Bias Current			5		μA
Sample-Hold Input Bandwidth	-3dBFS		100		MHz
Input Resistance			50		$\text{K}\Omega$
Input Capacitance			10		pF
Dynamic Performance					
Signal-to-Noise Ratio	Referred to Full Scale				
$f_{in} = 500\text{KHz}$			59		dB
$f_{in} = 1\text{MHz}$		54			dB
Spurious Free Dynamic Range	Referred to Full Scale				
$f_{in} = 500\text{KHz}$			68		dB
$f_{in} = 1\text{MHz}$		58	66		dB
Timing Characteristics					
Output Data Delay (td)			18	30	ns
Output Data Delay (tdsl)	(High 'Z')			100	ns
Data Valid Time	Tri-state circuit			100	ns
Sampling Time Offset			5	10	ns
Digital Inputs					
Input Current, Logic High	$V_{DD} = 5.25\text{V}$, $V_{IH} = V_{DD}$			100	μA
Input Current, Logic Low	$V_{DD} = 5.25\text{V}$, $V_{IL} = \text{DGND}$			10	μA
Pulse Width High (CLK)		83			ns
Pulse Width Low (CLK)		83			ns
Voltage, Logic High		4.0			V
Voltage, Logic Low				1.0	V
Digital Outputs					
Output Current, Logic High	$V_{DD} = \text{min}$ $V_{OH} = 4.25\text{V}$	-1.1			mA
Output Current, Logic Low	$V_{DD} = \text{min}$ $V_{OL} = 0.4\text{V}$	3.7			mA
Voltage, Logic High				4.0	V
Voltage, Logic Low				0.4	V
Power Supply Requirements					
AV_{DD} (Analog Supply Voltage)		+4.75	+5.0	+5.25	V
DV_{DD} (Digital Supply Voltage)		+4.75	+5.0	+5.25	V
Supply Voltage Difference	$(AV_{DD} - DV_{DD})$	-0.1	0.0	0.1	V
Supply Current	$f_s = 6\text{MSPS}$		65		mA
Power Dissipation			325		mW

Timing Specifications

Operating characteristic at $V_{DD}=5V$, $V_{RT}=3.0V$, $V_{RB}=1.0V$, $f_{(CLK)}=20MHz$, $T_A=25^{\circ}C$ (unless otherwise noted)

PARAMETERS	TEST CONDICTION	MIN	TYP	MAX	UNITS
f_{CONV} Maximum conversion rate		6			MSPS
t_d Sampling delay time			4		ns
t_{AJ} Aperture jitter time			30		ps
$tw(H)$ Clock pulse High		83			ns
$tw(L)$ Clock Pulse Low		83			ns
t_1 Data Hold time	$C_L=10pF$		15		ns
t_2 New Data delay time	$C_L=10pF$			20	ns

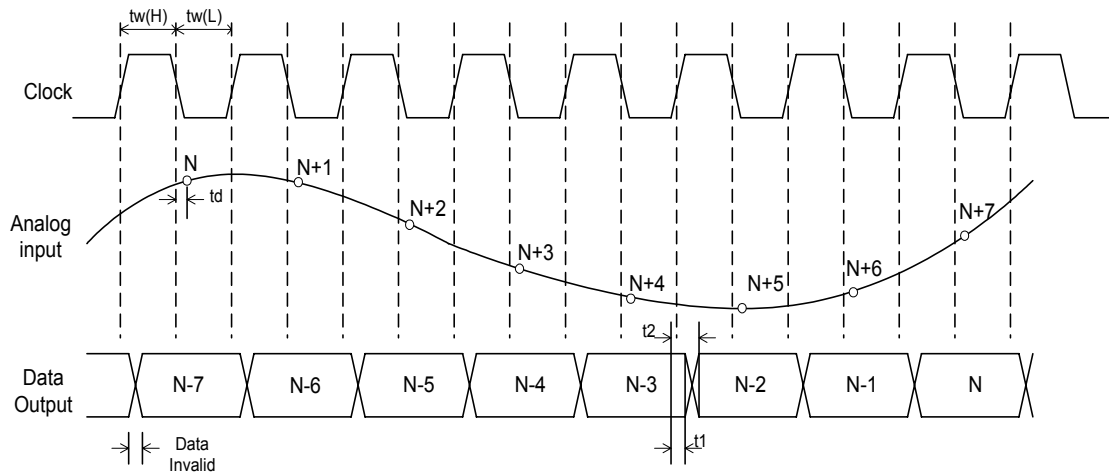

Typical Application Schematic

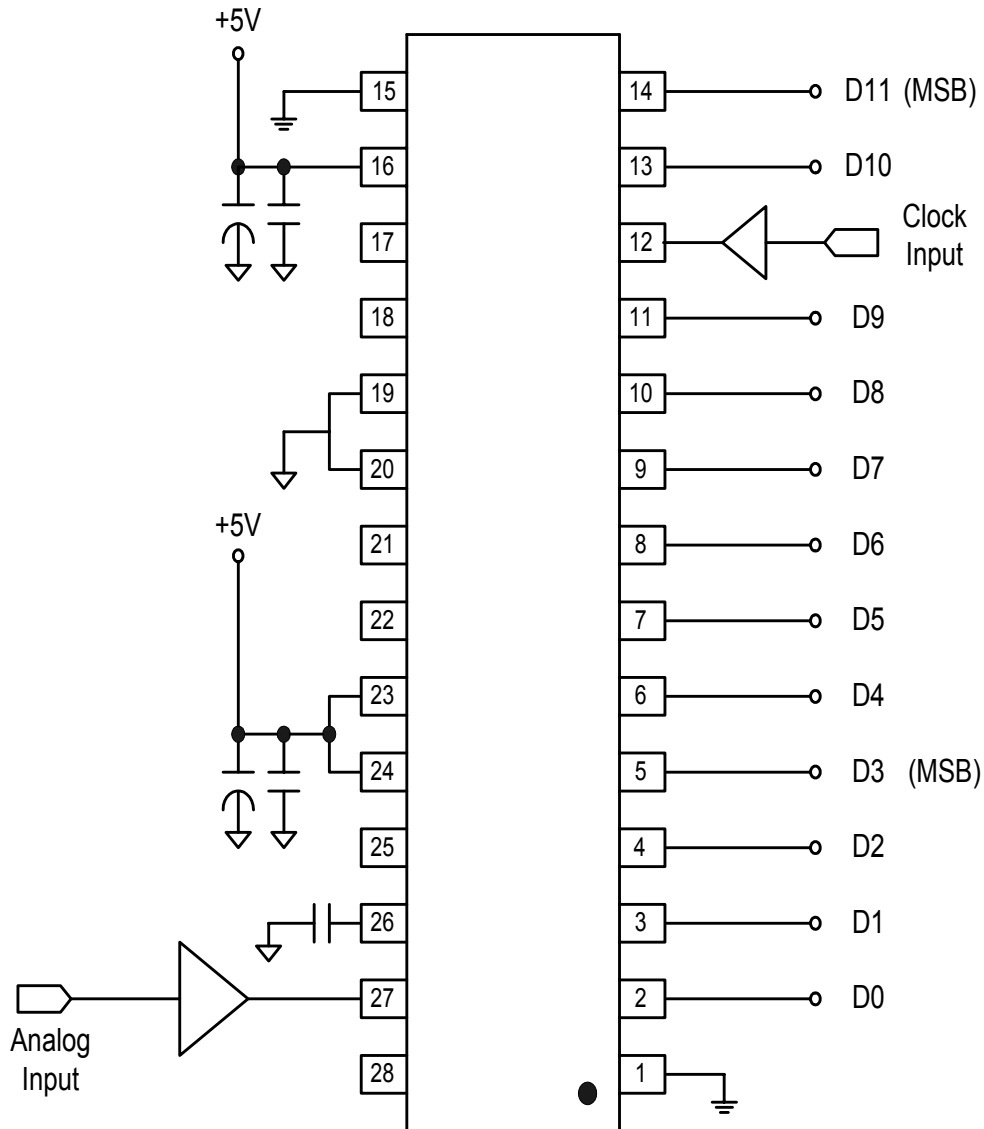

Package Outline (28-pin 300 mil SSOP)

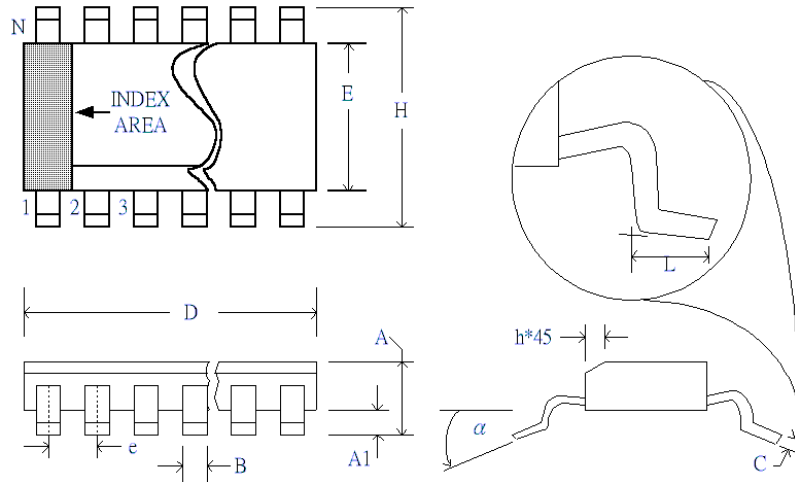

SYMBOLS	DIMENSIONS IN MILLIMETERS			DIMENSIONS IN INCHES		
	MIN	NOM	MAX	MIN	NOM	MAX
A	2.36	2.49	2.64	0.093	0.098	0.104
A1	0.10	-	0.30	0.004	-	0.012
A2	-	2.34	-	-	0.092	-
B	0.33	0.41	0.51	0.013	0.016	0.020
C	0.23	0.25	0.33	0.009	0.010	0.012
D	17.70	-	18.10	0.697	-	0.713
E	7.39	7.49	7.59	0.291	0.295	0.299
e	-	1.27	-	-	0.050	-
H	10.01	10.31	10.64	0.394	0.406	0.419
L	0.38	0.81	1.27	0.015	0.032	0.050
y	0	-	8	0	-	8
h	0.25	-	0.75	0.01	-	0.029

Reflow Condition (IR/Convection or VPR Reflow)

Reference JEDEC Standard J-STD-020A

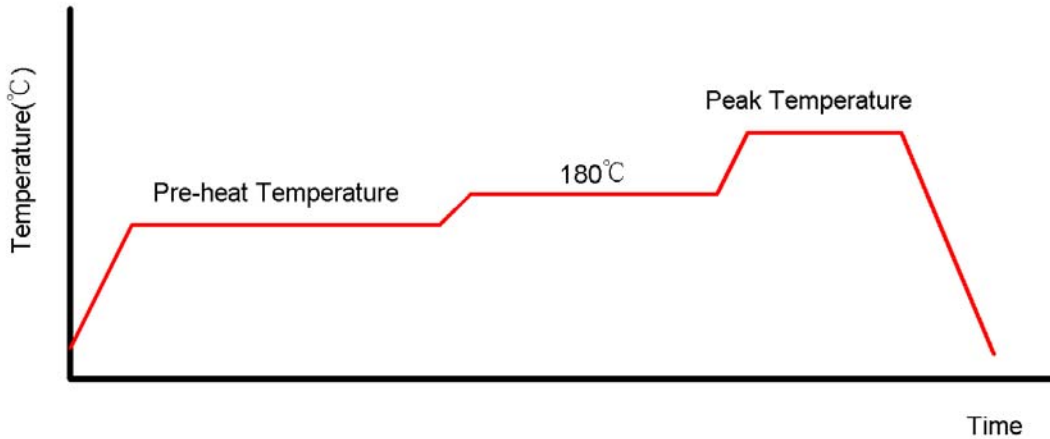

Classification Reflow Profiles

	Convection or IR/Convection	VPR
Average Heating Rate(180°C to peak)	5°C/second max.	10°C/second max.
Preheat Temperature(125±20°C)	120 seconds max.	
Temperature maintained above 180°C	10~150 seconds	
Time within 5°C of actual Peak Temperature	10~20 seconds	60 seconds
Peak Temperature Range(Note 1)	219~225°C or 235~240°C	219~225°C or 235~240°C
Cooling Rate	6°C /second max.	10°C/second max.
Time 25°C to Peak Temperature	6 minutes max.	

*1 The maximum peak temperatures for IR and VP reflow are depending on package dimensions.

Package Reflow Conditions

Pkg. Thickness ≥2.5mm and all bags	Pkg. Thickness <2.5mm and Pkg. Volume ≥350 mm ³	Pkg. Thickness <2.5mm and Pkg. Volume <350 mm ³
Convection 219~225°C		Convection 235~240°C
VPR 219~225°C		VPR 235~240°C
IR/Convection 219~225°C		IR/Convection 235~240°C