

## CA758

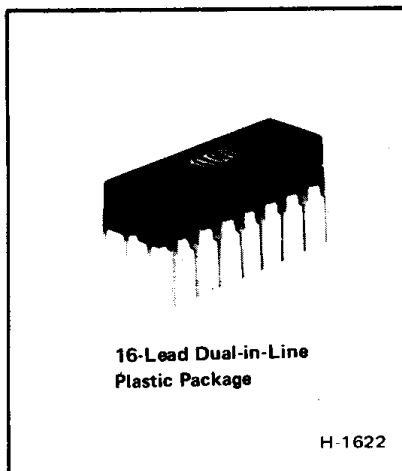

## RC Phase-Lock-Loop Stereo Decoder

For FM Multiplex Systems

### Features:

- Low distortion (THD): 0.4% (typ.)
- Excellent SCA rejection: 70 dB typ.
- RC oscillator
- High-audio-channel separation: 45 dB
- Power supply range: 10 to 16 V dc
- Requires only one adjustment for complete alignment
- Low-impedance outputs
- Stereo indicator lamp drive: 150 mA typ.

RCA-CA758E is a monolithic silicon integrated circuit RC phase-lock loop stereo decoder intended for FM solid-state stereo multiplex systems.

The CA758E is pin compatible and electrically equivalent to industry types  $\mu$ A758, MC1311P, LM1800, and ULX2244.

The CA758E decodes the multiplexed stereo input signal into left and right channel audio output signals. The decoder also suppresses SCA (storecast) transmissions when present in the composite stereo signal.

The decoder uses a minimum of external components, and requires one adjustment (oscillator frequency) for complete alignment. In addition, the CA758E provides automatic mono-stereo mode switching and energizes a stereo indicator lamp.

The CA758E is supplied in a 16-lead dual-in-line plastic package and operates over an ambient temperature range of  $-40$  to  $+85^{\circ}\text{C}$ .

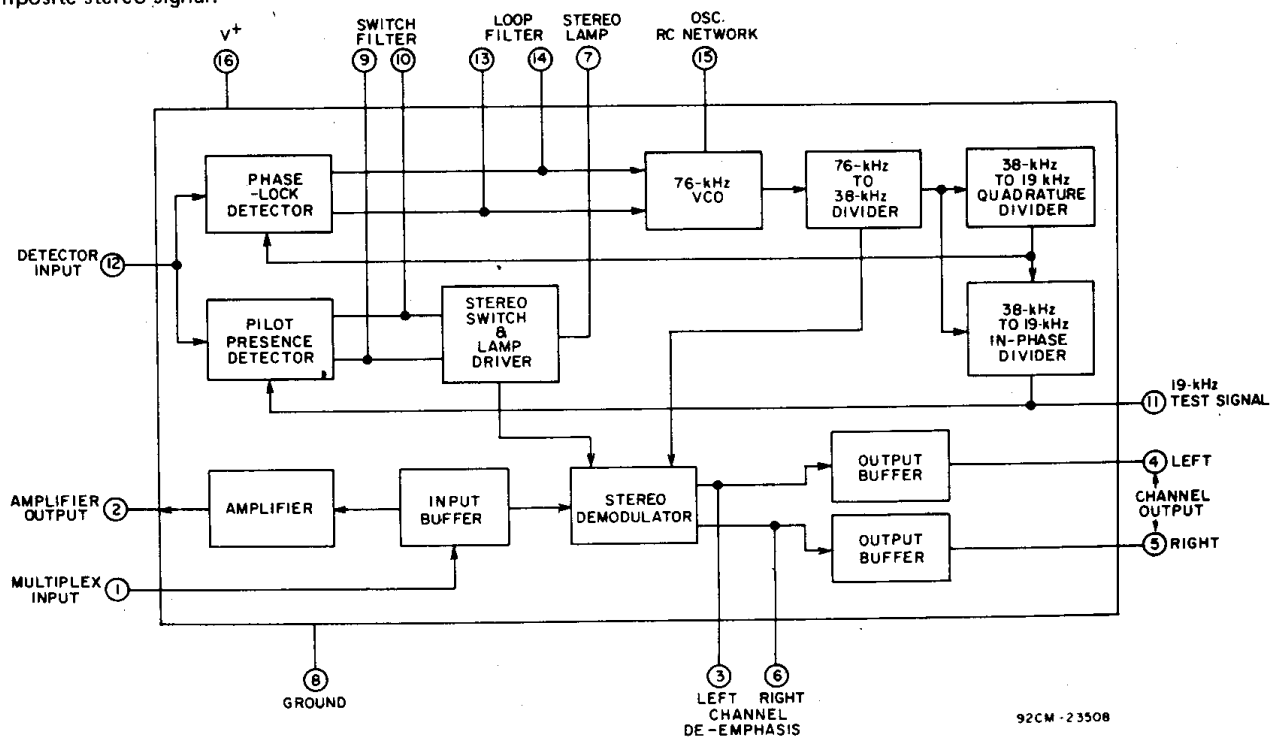

Fig. 1 - Functional block diagram of the CA758E.

## MAXIMUM RATINGS, Absolute-Maximum Values at $T_A = 25^\circ\text{C}$

DC Supply Voltage . . . . .	+18 V
DC Supply Voltage (for $\leq$ a 15-second period) . . . . .	+22 V
DC Voltage at Term. 7 (Lamp Driver Circuit with Lamp "OFF") . . . . .	+22 V
Device Dissipation:	
Up to $T_A = 70^\circ\text{C}$ . . . . .	730 mW
Above $T_A = 70^\circ\text{C}$ derate linearly . . . . .	9.1 mW/ $^\circ\text{C}$
Ambient Temperature Range:	
Operating . . . . .	-40 to +85 $^\circ\text{C}$
Storage . . . . .	-65 to +150 $^\circ\text{C}$
Lead Temperature (During soldering):	
At a distance not less than 1/32" (0.79 mm)	
from case for 10 s max. . . . .	+265 $^\circ\text{C}$

## ELECTRICAL CHARACTERISTICS

CHARACTERISTIC	TEST CONDITIONS (Referenced to Fig. 3 unless otherwise specified) $V^+ = 12\text{ V}, T_A = 25^\circ\text{C}$ Multiplex Input Signal (L=R, pilot "OFF") = 300 mV RMS 19-kHz Pilot Level = 30 mV RMS f (modulation) = 400 Hz or 1 kHz	LIMITS			UNITS
		Min.	Typ.	Max.	
<b>Static Characteristics</b>					
Total Current	Lamp "OFF"	—	26	35	mA
Maximum Available Lamp Current		75	150	—	mA
DC Voltage at Term. 7 (Lamp Driver)	I (Lamp) = 50 mA	—	1.3	1.8	V
DC Voltage Shift at either Term. 4 or 5 (Output)	Stereo-to-Mono Operation	—	30	150	mV
<b>Dynamic Characteristics</b>					
Power Supply Ripple Rejection	For a 200-Hz, 200-mV RMS Signal	35	45	—	dB
Input Resistance		20	35	—	k $\Omega$
Output Resistance		0.9	1.3	2.0	k $\Omega$
Channel Separation (Stereo)	At f = 100 Hz	—	40	—	dB
	f = 400 Hz	30	45	—	dB
	f = 10 kHz	—	45	—	dB
Channel Balance (Monaural)		—	0.3	1.5	dB
Voltage Gain	At f = 1 kHz	0.5	0.9	1.4	V/V
Pilot Input Level:					
19-kHz Input	Lamp "ON"	—	15	20	mV RMS
19-kHz Input	Lamp "OFF"	2.0	7.0	—	mV RMS
Hysteresis	Lamp "OFF"	3.0	7.0	—	dB
Capture Range (Deviation from 76-kHz Center Frequency)		$\pm 2.0$	$\pm 4.0$	$\pm 6.0$	%
Total Harmonic Distortion	Multiplex Input Signal = 600 mV RMS (Pilot "OFF")	—	0.4	1.0	%
19-kHz Rejection		25	35	—	dB
38-kHz Rejection		25	45	—	dB
SCA (Storecast) Rejection	Measured Composite Signal: 80% Stereo, 10% Pilot, 10% SCA	—	70	—	dB
Voltage-Controlled Oscillator (VCO) Tuning Resistance	Total Resistance (Term. 15 to 8) required to set $f_{\text{REF}} = 19\text{ kHz} \pm 10\text{ Hz}$ (Term. 11)	21.0	23.3	25.5	k $\Omega$
Voltage-Controlled Oscillator Frequency Drift	$0^\circ \leq T_A \leq 25^\circ\text{C}$	—	+0.1	$\pm 2$	%
	$25^\circ \leq T_A \leq 70^\circ\text{C}$	—	-0.4	$\pm 2$	%

CA758

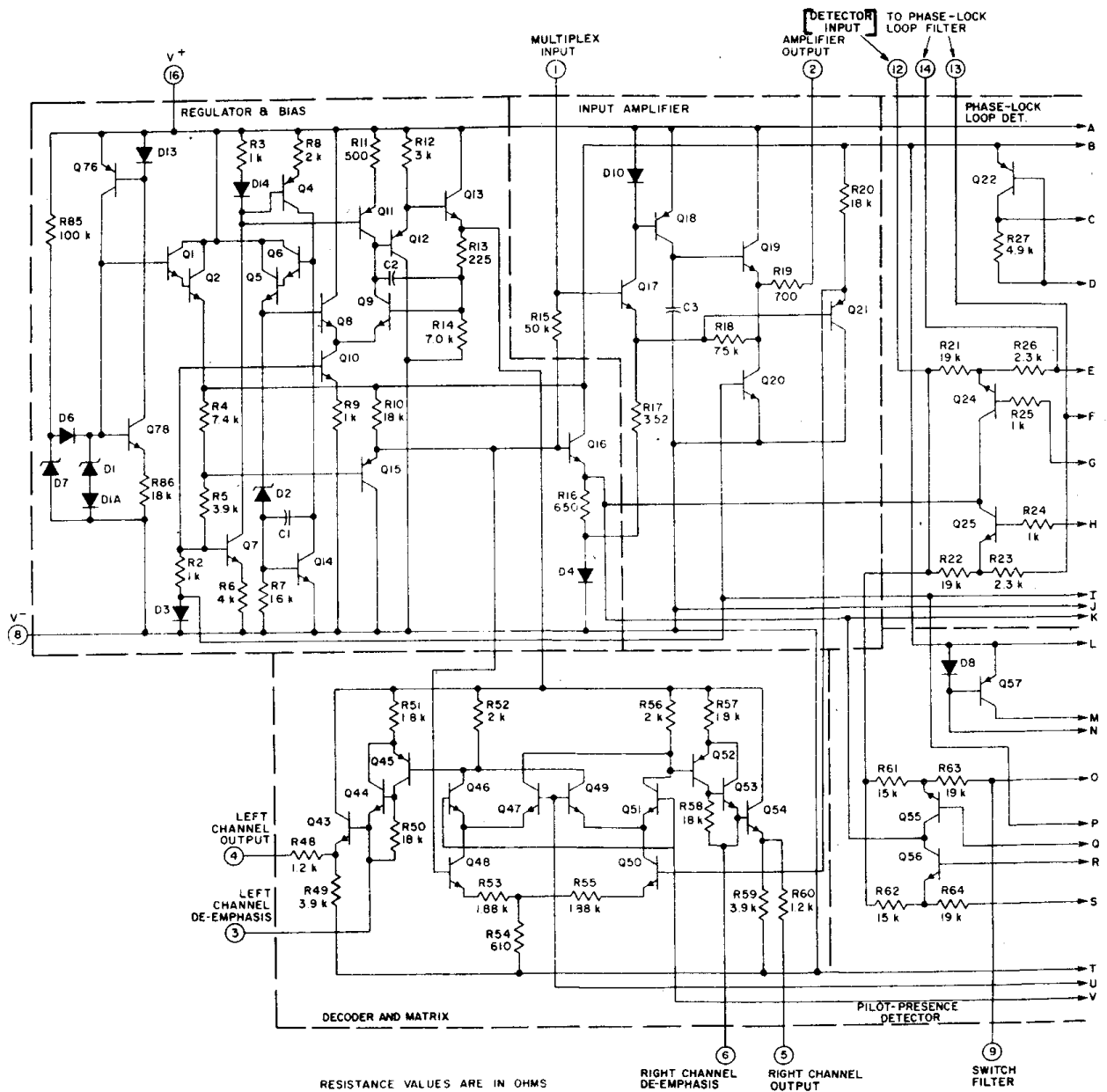

Fig. 2 - Schematic diagram of the CA758E.

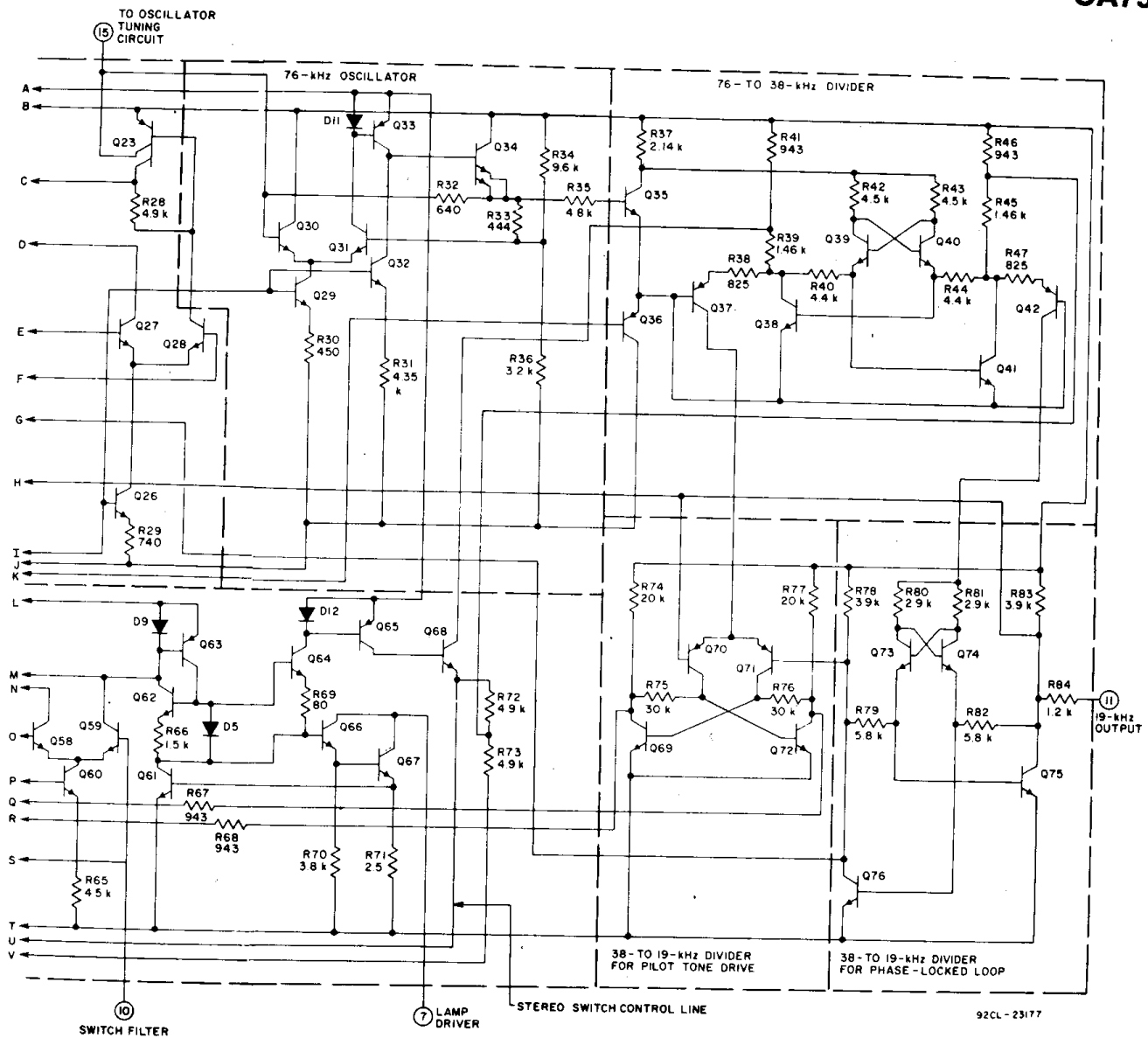
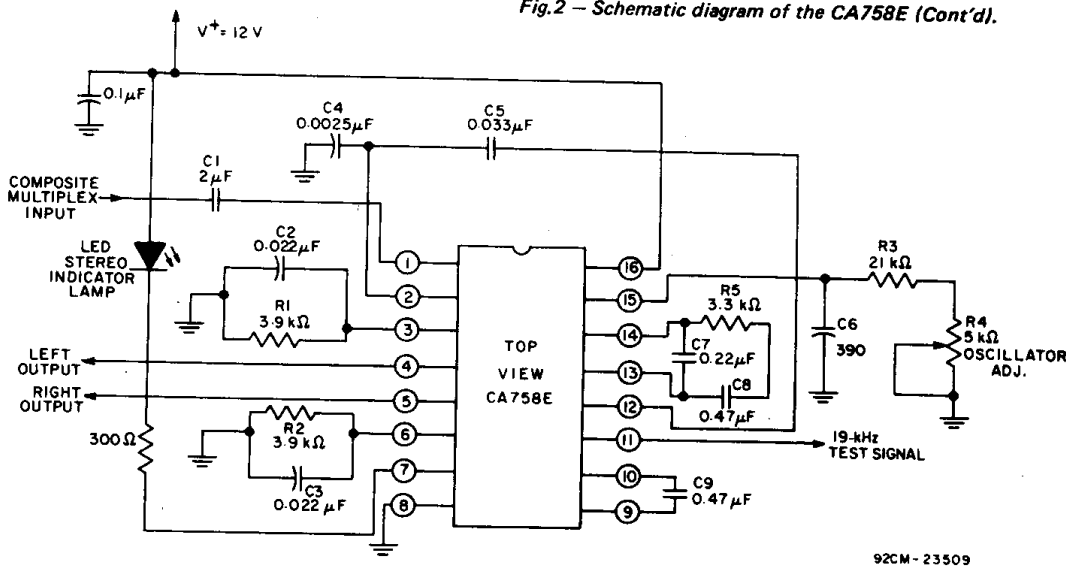

Fig.2 - Schematic diagram of the CA758E (Cont'd).



- NOTES:
- Tolerance on resistors is  $\pm 5\%$  and tolerance on capacitors is  $\pm 20\%$  unless otherwise specified.
  - C<sub>1</sub> = +100%, -20%
  - C<sub>6</sub> =  $\pm 1\%$  in test circuit and  $\pm 5\%$  in typical application.
  - R<sub>3</sub> =  $\pm 1\%$
  - R<sub>4</sub> =  $\pm 10\%$
  - R<sub>1</sub> and R<sub>2</sub> =  $\pm 1\%$  in test circuit and  $\pm 5\%$  in typical application.

Fig. 3 - Test circuit for measurement of dynamic characteristics.

CA758

TYPICAL PERFORMANCE CHARACTERISTICS (Referenced to Fig. 3)

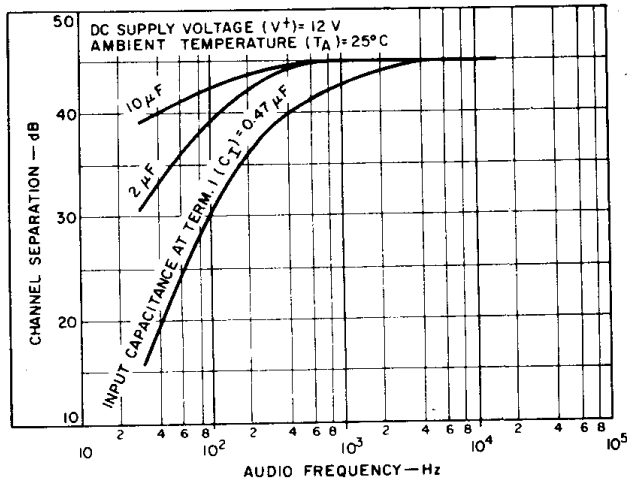

Fig. 4 - Channel separation vs. audio frequency.

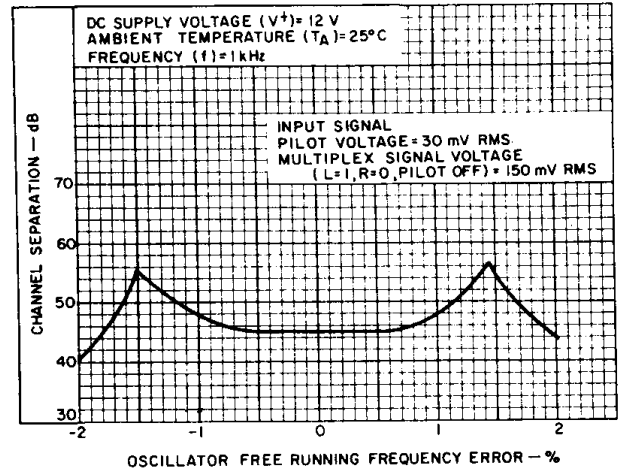

Fig. 5 - Channel separation vs. oscillator free running frequency error.

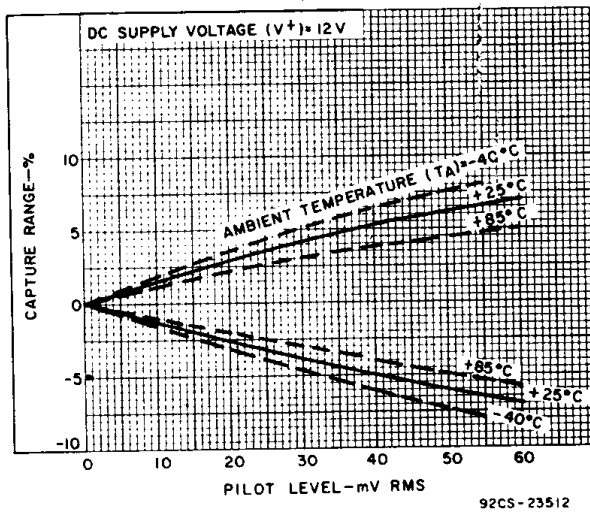

Fig. 6 - Capture range vs. pilot level.

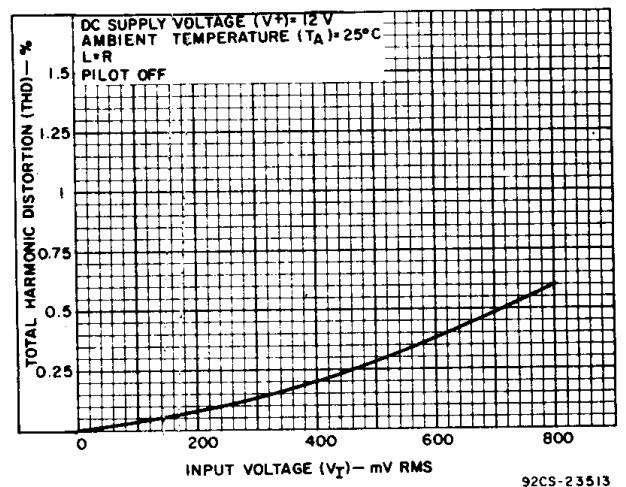

Fig. 7 - Total harmonic distortion vs. input level.

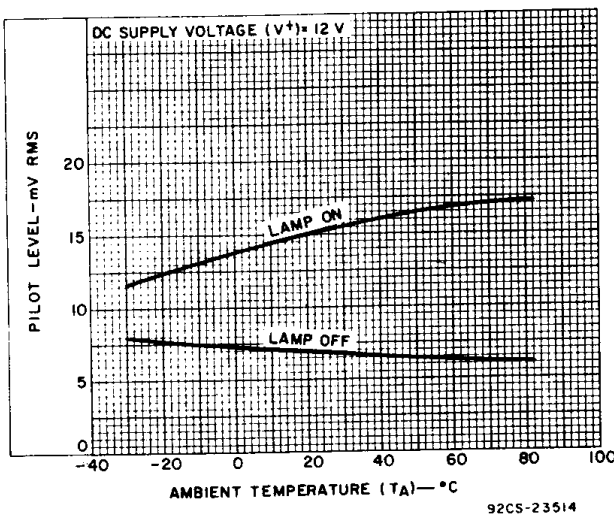

Fig. 8 - Lamp turn-on and turn-off sensitivity vs. ambient temperature.

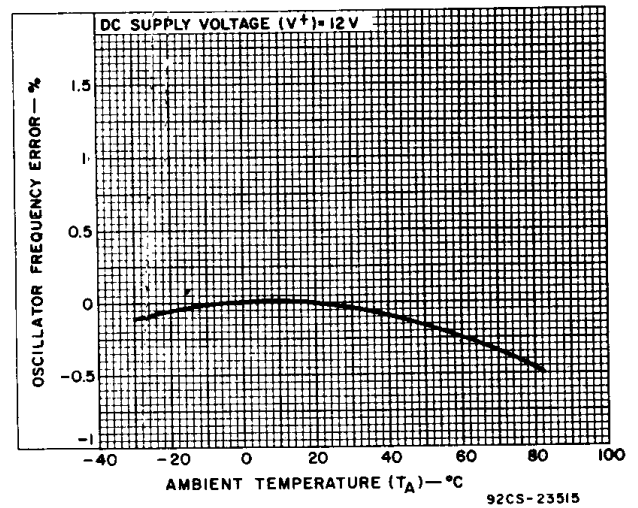

Fig. 9 - Oscillator free running frequency error vs. ambient temperature.