

TriQuint's GA1087 is a configurable clock buffer which generates 11 outputs, operating over a wide range of frequencies — from 24 MHz to 105 MHz. The outputs are available at either 1x and 2x or at 1x and $\frac{1}{2}$ x the reference clock frequency, f_{REF} . When one of the Group A outputs (Q5–Q10) is used as feedback to the PLL, all Group A outputs will be at f_{REF} , and all Group B outputs (Q0–Q4) will be at $\frac{1}{2}$ x f_{REF} . When one of the Group B outputs is used as feedback to the PLL, all Group A outputs will be at 2x f_{REF} and all Group B outputs will be at f_{REF} .

A very stable internal Phase-Locked Loop (PLL) provides low-jitter operation. Completely self-contained, this PLL requires no external capacitors or resistors. The PLL's voltage-controlled oscillator (VCO) has a frequency range from 280 MHz to 420 MHz. By feeding back one of the output clocks to FBIN, the PLL continuously maintains frequency and phase synchronization between the reference clock (REFCLK) and each of the outputs.

TriQuint's patented output buffer design delivers a very low output-to-output skew of 150 ps (max). The GA1087's symmetrical TTL outputs are capable of sourcing and sinking 30 mA.

GA1087

11-Output Configurable Clock Buffer

Features

- Wide frequency range: 24 MHz to 105 MHz
- Output configurations: five outputs at f_{REF} , five outputs at $f_{REF}/2$ or six outputs at $2x f_{REF}$, four outputs at f_{REF}
- Low output-to-output skew: 150 ps (max) within a group
- Near-zero propagation delay: -350 ps ± 500 ps (max) or -350 ps ± 700 ps (max)
- TTL-compatible with 30 mA output drive
- 28-pin J-lead surface-mount package

Functional Description

The core of the GA1087 is a Phase-Locked Loop (PLL) that continuously compares the reference clock (REFCLK) to the feedback clock (FBIN), maintaining a zero frequency difference between the two. Since one of the outputs (Q0–Q8) is always connected to FBIN, the PLL keeps the propagation delay between the outputs and the reference clock within $-350\text{ ps} \pm 500\text{ ps}$ for the GA1087-MC500, and within $-350\text{ ps} \pm 700\text{ ps}$ for the GA1087-MC700.

The internal voltage-controlled oscillator (VCO) has an operating range of 280 MHz to 420 MHz. The combination of the VCO and the Divide Logic enables the GA1087 to operate between 24 MHz and 105 MHz.

The device features six divide modes: $\div 4$, $\div 5$, $\div 6$, $\div 8$, $\div 10$, and $\div 12$. The Frequency Select pins, F0 and F1,

and the output used as feedback to FBIN set the divide mode as shown in Table 1.

In the test mode, the PLL is bypassed and REFCLK is connected directly to the Divide Logic block via the MUX, as shown in Figure 1. This mode is useful for debug and test purposes. The various test modes are outlined in Table 2. In the test mode, the frequency of the reference clock is divided by 4, 5, or 6.

The maximum rise and fall time at the output pins is 1.4 ns. All outputs of the GA1087 are TTL-compatible with 30 mA symmetric drive and a minimum V_{OH} of 2.4 V.

Power Up/Reset Synchronization

After-power-up or reset, the PLL requires time before it achieves synchronization lock. The maximum time required for synchronization (TSYNC) is 500 ms.

Table 1. Frequency Mode Selection

Feedback: Any Group A Output (Q5 – Q10)

Test	Select Pins		Mode	Reference Clock Frequency Range	Output Frequency Range	
	F0	F1			Group A: Q5–Q10	Group B: Q0–Q4
0	1	0	$\div 4$	70 MHz – 105 MHz	70 MHz – 105 MHz	35 MHz – 52 MHz
0	0	0	$\div 5$	56 MHz – 84 MHz	56 MHz – 84 MHz ¹	28 MHz – 42 MHz
0	0	1	$\div 6$	48 MHz – 70 MHz	48 MHz – 70 MHz	24 MHz – 35 MHz
0	1	1	Not Used	N.A.	N.A.	N.A.

Feedback: Any Group B Output (Q0 – Q4)

Test	Select Pins		Mode	Reference Clock Frequency Range	Output Frequency Range	
	F0	F1			Group A: Q5–Q10	Group B: Q0–Q4
0	1	0	$\div 8$	35 MHz – 52 MHz	70 MHz – 105 MHz	35 MHz – 52 MHz
0	0	0	$\div 10$	28 MHz – 42 MHz	56 MHz – 84 MHz ¹	28 MHz – 42 MHz
0	0	1	$\div 12$	24 MHz – 35 MHz	48 MHz – 70 MHz	24 MHz – 35 MHz
0	1	1	Not Used	N.A.	N.A.	N.A.

Notes: 1. This mode produces outputs with 40/60 duty cycle for Q5 – Q10 only.

Table 2. Test Mode Selection

Test	F0	F1	Mode	Ref. Clock	Group B: Outputs Q0–Q4	Group A: Outputs Q5–Q10
1	1	0	÷ 4	f_{REF}	$f_{REF} \div 8$	$f_{REF} \div 4$
1	0	0	÷ 5	f_{REF}	$f_{REF} \div 10$	$f_{REF} \div 5$
1	0	1	÷ 6	f_{REF}	$f_{REF} \div 12$	$f_{REF} \div 6$
1	1	1	—	—	—	—

Layout Guidelines

Multiple ground and power pins on the GA1087 reduce ground bounce. Good layout techniques, however, are necessary to guarantee proper operation and to meet the specifications across the full operating range. TriQuint recommends bypassing each of the V_{DD} supply pins to the nearest ground pin, as close to the chip as possible.

Figure 2 shows the recommended power layout for the GA1087. The bypass capacitors should be located on the same side of the board as the GA1087. The V_{DD} traces connect to an inner-layer V_{DD} plane. All of the ground pins (GND) are connected to a small ground plane on the surface beneath the chip. Multiple through holes connect this small surface plane to an inner-layer ground plane. The capacitors (C1–C5) are 0.1 mF. TriQuint’s test board uses X7R temperature-stable capacitors in 1206 SMD cases.

Figure 2. Top Layer Layout of Power Pins (approx. 3.3x)

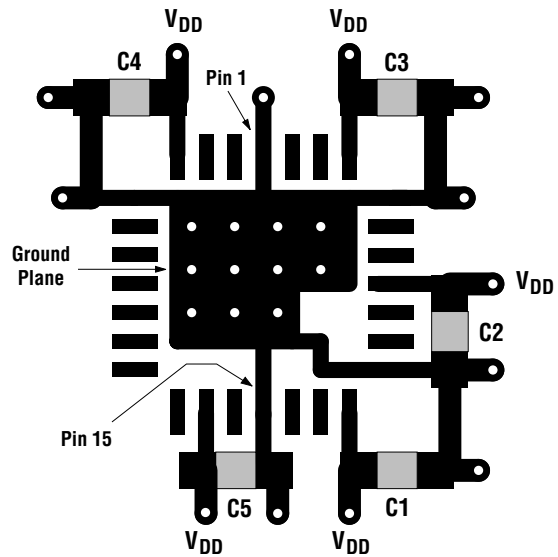

SYSTEM TIMING PRODUCTS

GA1087

Absolute Maximum Ratings ¹

Storage temperature	-65 °C to +150 °C
Ambient temperature with power applied ²	-55 °C to +100 °C
Supply voltage to ground potential	-0.5 V to +7.0 V
DC input voltage	-0.5 V to (V _{DD} + 0.5) V
DC input current	-30 mA to +5 mA
Package thermal resistance (MQuad)	θ _{JA} = 45 °C/W
Die junction temperature	T _J = 150 °C

DC Characteristics (V_{DD} = +5 V ± 5%, T_A = 0 °C to +70 °C) ³

Symbol	Description	Test Conditions	Min	Limits ⁴		Units
				Typ	Max	
V _{OHT}	Output HIGH voltage	V _{DD} = Min V _{IN} = V _{IH} or V _{IL}	2.4	3.4		V
V _{OHC}	Output HIGH voltage V _{IN}	V _{DD} = Min = V _{IH} or V _{IL}	3.2	4.1		V
V _{OL}	Output LOW voltage V _{IN}	V _{DD} = Min = V _{IH} or V _{IL}		0.27	0.5	V
V _{IH} ⁵	Input HIGH level Voltage for all Inputs	Guaranteed input logical HIGH	2.0			V
V _{IL} ⁵	Input LOW level Voltage for all inputs	Guaranteed input logical LOW			0.8	V
I _{IL}	Input LOW current	V _{DD} = Max V _{IN} = 0.40 V		-156	-400	μA
I _{IH}	Input HIGH current	V _{DD} = Max V _{IN} = 2.7 V		0	25	μA
I _I	Input HIGH current	V _{DD} = Max V _{IN} = 5.5 V		2	1000	μA
I _{DDSD} ⁶	Power supply current	V _{DD} = Max		119	160	mA
V _I	Input clamp voltage	V _{DD} = Min I _{IN} = -18 mA		-0.70	-1.2	V

Capacitance

Symbol	Description	Test Conditions	Min	Typ	Max	Units
C _{IN} ^{3,7}	Input capacitance	V _{IN} = 2.0 V at f = 1 MHz		6		pF

- Notes:
1. Exceeding these parameters may damage the device.
 2. Maximum ambient temperature with device not switching and unloaded.
 3. These values apply to both GA1087-MC500 and GA1087-MC700.
 4. Typical limits are at V_{DD} = 5.0 V and T_A = 25 °C.
 5. These are absolute values with respect to device ground and all overshoots due to system or tester noise are included.
 6. This parameter is measured with device not switching and unloaded.
 7. These parameters are not 100% tested, but are periodically sampled.

AC Characteristics ($V_{DD} = +5 V \pm 5\%$, $T_A = 0^\circ C$ to $+70^\circ C$)

Symbol	Input Clock (REFCLK)	Test Conditions (Figure 3) ¹	Min	Typ	Max	Unit
t_{CPWH}	CLK pulse width HIGH	Figure 4	3	---	---	ns
t_{CPWL}	CLK pulse width LOW	Figure 4	3	---	---	ns
t_{IR}	Input rise time (0.8 V - 2.0 V)		---	---	2.0	ns

Symbol	Input Clock (Q0-Q10)	Test Conditions (Figure 3) ¹	Min	Typ	Max	Unit
t_{OR}, t_{OF}	Rise/fall time (0.8 V - 2.0 V)	Figure 4	350	---	1400	ps
t_{PD1} ²	CLK \uparrow to FBIN \uparrow (GA1087-MC500)	Figure 4	-850	-350	+150	ps
t_{PD2} ²	CLK \uparrow to FBIN \uparrow (GA1087-MC700)	Figure 4	-1050	-350	+350	ps
t_{SKEW1} ³	Rise-rise, fall-fall (within group)	Figure 5	---	60	150	ps
t_{SKEW2} ³	Rise-rise, fall-fall (group-to-group, aligned)	Figure 6 (skew2 takes into account skew1)	---	75	350	ps
t_{SKEW3} ³	Rise-rise, fall-fall (group-to-group, non-aligned)	Figure 7 (skew3 takes into account skew1, 2)	---	---	650	ps
t_{SKEW4} ³	Rise-fall, fall-rise	Figure 8 (skew4 takes into account skew3)	---	---	1200	ps
t_{CYC} ⁴	Duty-cycle Variation	Figure 4	-1000	0	+1000	ps
t_{JP} ⁵	Period-to-Period Jitter	Figure 4	---	80	200	ps
t_{JR} ⁵	Random Jitter	Figure 4	---	190	400	ps
t_{SYNC} ⁶	Synchronization Time		---	10	500	μ s

- Notes:
1. All measurements are tested with a REFCLK having a rise time of 0.5 ns (0.8 V to 2.0 V).
 2. The PLL maintains alignment of CLK and FBIN at all times. This specification applies to the rising edge only because the input duty cycle can vary. while the output duty cycle is typically 50/50. The delay t_{PD} is measured at the 1.5 V level between CLK and FBIN.
 3. Skew specifies the width of the window in which outputs switch, and is measured at 1.5 V.
 4. This specification represents the deviation from 50/50 on the outputs.
 5. Jitter specifications refer to peak-to-peak value. t_{JR} is the jitter on the output with respect to the reference clock. t_{JP} is the jitter on the output with respect to the output's previous rising edge.
 6. t_{SYNC} is the time required for the PLL to synchronize; this assumes the presence of a CLK signal and a connection from one of the outputs to FBIN.

Figure 3. AC Test Circuit

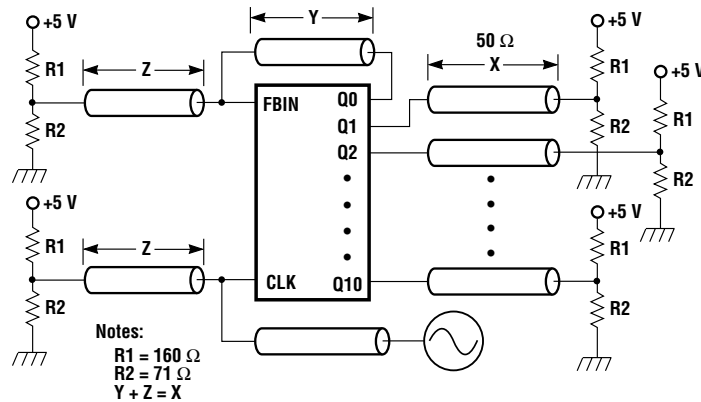

SYSTEM TIMING PRODUCTS

Switching Waveforms

Figure 4. General Timing

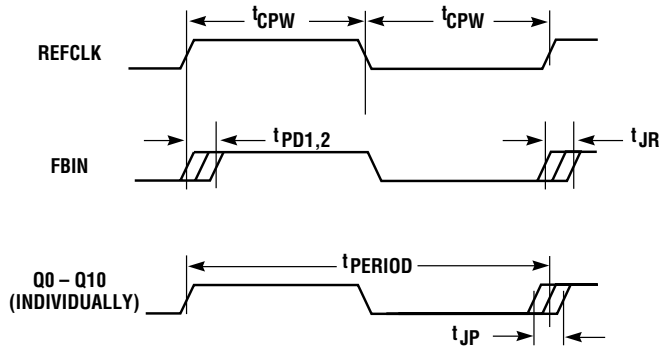

Figure 5. t_{SKEW1}

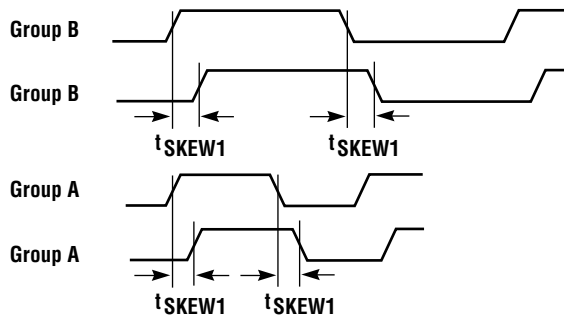

Figure 7. t_{SKEW3} (For Group B Feedback)

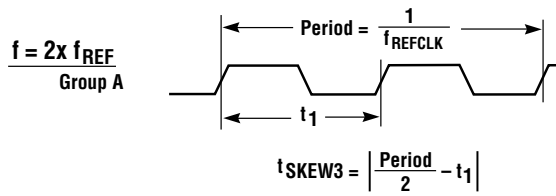

Figure 6. t_{SKEW2}

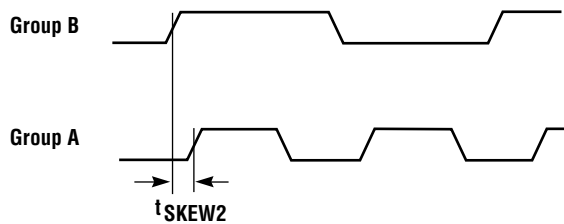
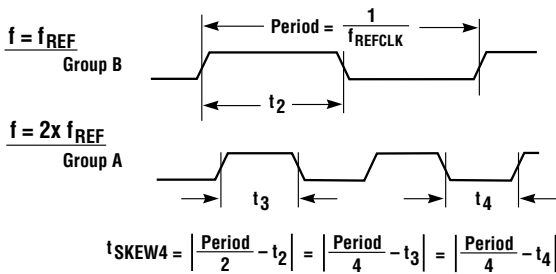
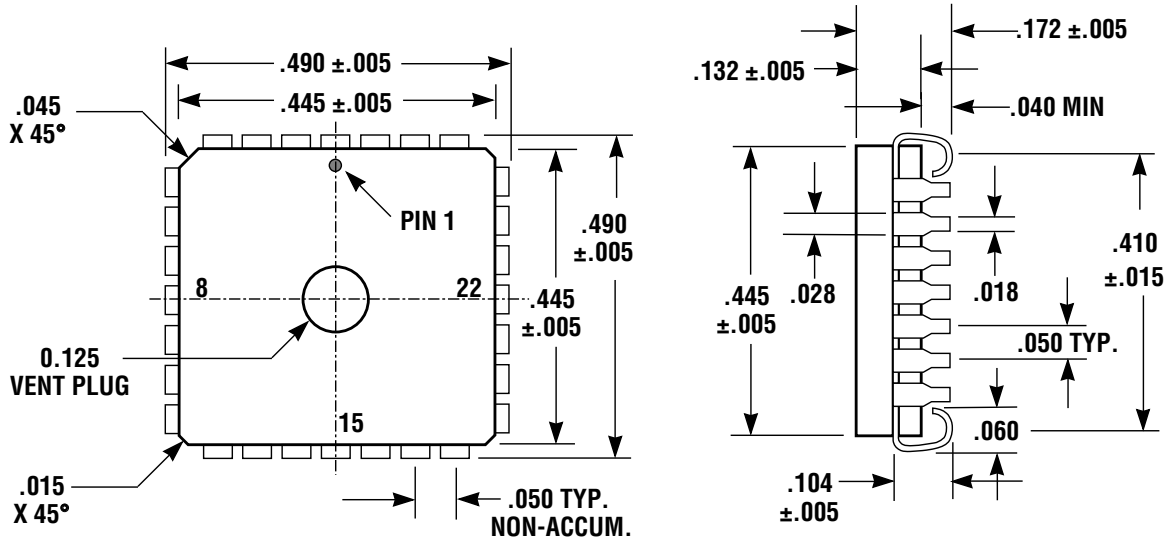

Figure 8. t_{SKEW4}



28-Pin MQuad J-Leaded Package Mechanical Specification

(All dimensions in inches)



28-Pin MQuad Pin Description

Pin #	Pin Name	Description	I/O
1	GND	Ground	—
2	Q9	Output Clock 9 (A5)	O
3	Q10	Output Clock 10 (A6)	O
4	VDD	+5 V	—
5	GND	Ground	—
6	F0	Frequency Select 0	I
7	F1	Frequency Select 1	I
8	GND	Ground	—
9	REFCLK	Reference Clock	I
10	GND	Ground	—
11	FBIN	Feedback In	I
12	TEST	Test	I
13	VDD	+5 V	—
14	Q0	Output Clock 0 (B1)	O

Pin #	Pin Name	Description	I/O
15	GND	Ground	—
16	Q1	Output Clock 1 (B2)	O
17	Q2	Output Clock 2 (B3)	O
18	VDD	+5 V	—
19	GND	Ground	—
20	Q3	Output Clock 3 (B4)	O
21	Q4	Output Clock 4 (B5)	O
22	VDD	+5 V	—
23	Q5	Output Clock 5 (A1)	O
24	Q6	Output Clock 6 (A2)	O
25	GND	Ground	—
26	VDD	+5 V	—
27	Q7	Output Clock 7 (A3)	O
28	Q8	Output Clock 8 (A4)	O

SYSTEM TIMING PRODUCTS

Output Characteristics

The IV characteristics, transition times, package characteristics, device and bond wire-characteristics for the QA1087 are described in Tables 4 through 9 and Figures 9 through 11.

These output characteristics are provided for modeling purposes only. TriQuint does not guarantee the information in these tables and figures.

Figure 9. I_{OH} vs. V_{OH}

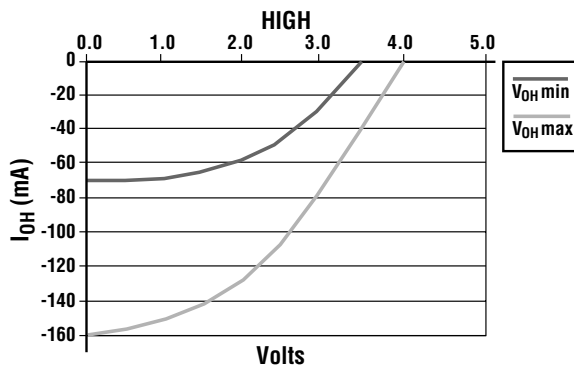

Table 4. I_{OH} vs. V_{OH}

V_{OL}	$I_{OL} \text{ min (mA)}$	$I_{OL} \text{ max (mA)}$
0.0	-70	-160
0.5	-70	-157
1.0	-68	-152
1.5	-65	-142
2.0	-59	-130
2.5	-48	-106
3.0	-29	-79
3.5	0	-42
4.0	0	0
4.5	0	0
5.0	0	0
6.0	0	0
7.0	0	0
8.0	0	0
9.0	0	1
10.0	0	5

Figure 10. I_{OL} vs. V_{OL}

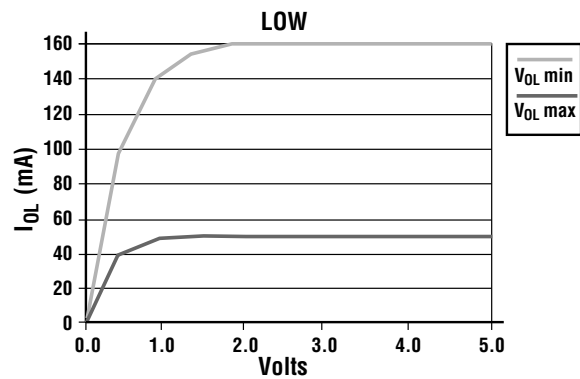

Table 5. I_{OL} vs. V_{OL}

V_{OL}	$I_{OL} \text{ min (mA)}$	$I_{OL} \text{ max (mA)}$
-2.5	-145	-435
-2.0	-135	-410
-1.5	-115	-350
-1.0	-90	-265
-0.5	-40	-120
0.0	0	0
0.5	37	97
1.0	49	140
1.5	53	155
2.0	54	157
2.5	54	159
3.0	54	160
3.5	54	160
4.0	54	160
4.5	54	160
5.0	54	160
10.0	54	160

Notes: 1. These are worst-case corners for process, voltage, and temperature.
2. Includes diode to ground current.

Table 6. Above- V_{DD} and Below-Ground Characteristics

Diode to GND		Diode Stack to VDD	
V	I (mA)	V	I (mA)
0.0	0	5.0	0
-0.4	0	6.0	0
-0.5	0	7.0	0
-0.6	-5	8.0	0
-0.7	-15	9.0	0
-0.8	-35	10.0	1
-0.9	-55	11.0	5
-1.0	-75	12.0	9
-2.0	-300		
-2.5	-350		
-3.0	-360		

Note: TriQuint does not guarantee diode operation for purposes other than ESD protection.

Figure 11. Output Model

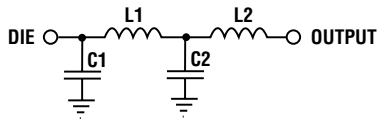

Table 7. Device and Bond-Wire Characteristics (Estimates)

L1	C1
2 nH	10 pF

Table 8. 28-Pin MQuad Package Characteristics

L1	C1
1.85 nH	0.40 pF

Table 9. Rise and Fall Times (Into 0 pF, 50 Ohms to 1.5 V)

Time (ns)	T_R min (V)	T_R max (V)	T_F min (V)	T_F max (V)
0.0	0.15	0.32	3.20	3.04
0.1	0.15	0.32	3.20	3.04
0.2	0.16	0.32	3.06	2.95
0.3	0.18	0.32	2.86	2.90
0.4	0.23	0.32	2.62	2.68
0.5	0.26	0.32	2.38	2.50
0.6	0.34	0.32	2.17	2.36
0.7	0.46	0.34	2.00	2.22
0.8	0.67	0.39	1.85	2.09
0.9	0.89	0.49	1.69	1.95
1.0	1.12	0.63	1.52	1.86
1.1	1.32	0.86	1.38	1.68
1.2	1.50	1.09	1.26	1.59
1.3	1.73	1.27	1.12	1.49
1.4	1.93	1.45	0.96	1.36
1.5	2.15	1.64	0.83	1.23
1.6	2.75	2.23	0.52	0.95
1.7	2.58	2.00	0.61	1.00
1.8	2.75	2.23	0.52	0.95
1.9	2.90	2.41	0.45	0.91
2.0	3.02	2.50	0.39	0.86
2.1	3.12	2.64	0.33	0.77
2.2	3.17	2.77	0.29	0.73
2.3	3.19	2.86	0.24	0.68
2.4	3.20	2.95	0.21	0.64
2.5	3.20	2.99	0.19	0.59
2.6	3.20	3.02	0.17	0.55
2.7	3.20	3.02	0.16	0.53
2.8	3.20	3.04	0.16	0.50
2.9	3.20	3.04	0.15	0.45
3.0	3.20	3.04	0.15	0.41
3.1	3.20	3.04	0.15	0.40
3.2	3.20	3.04	0.15	0.37
3.3	3.20	3.04	0.15	0.36
3.4	3.20	3.04	0.15	0.32

SYSTEM TIMING PRODUCTS

Ordering Information

To order, please specify as shown below:

GA1087-MC nnn 11-Output Configurable Clock Buffer

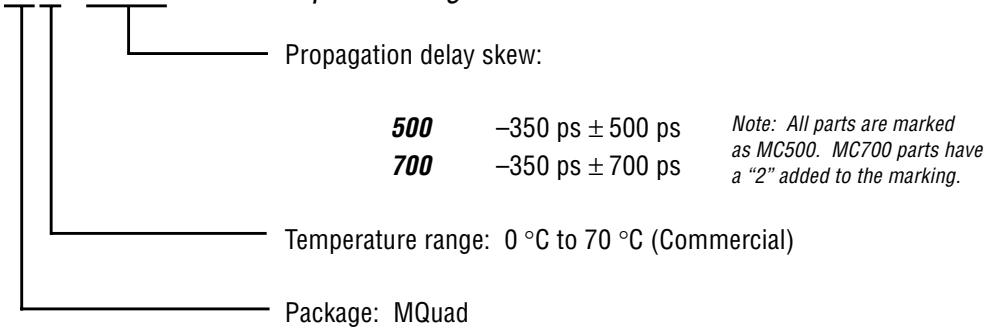

Additional Information

For latest specifications, additional product information, worldwide sales and distribution locations, and information about TriQuint:

Web: www.triquint.com **Tel:** (503) 615-9000
Email: sales@tqs.com **Fax:** (503) 615-8900

For technical questions and additional information on specific applications:

Email: applications@tqs.com

The information provided herein is believed to be reliable; TriQuint assumes no liability for inaccuracies or omissions. TriQuint assumes no responsibility for the use of this information, and all such information shall be entirely at the user's own risk. Prices and specifications are subject to change without notice. No patent rights or licenses to any of the circuits described herein are implied or granted to any third party. TriQuint does not authorize or warrant any TriQuint product for use in life-support devices and/or systems.

Copyright © 1997 TriQuint Semiconductor, Inc. All rights reserved.
Revision 1.1.A November 1997