

## 74F382 4-Bit Arithmetic Logic Unit

### General Description

The 74F382 performs three arithmetic and three logic operations on two 4-bit words, A and B. Two additional Select input codes force the Function outputs LOW or HIGH. An Overflow output is provided for convenience in twos complement arithmetic. A Carry output is provided for ripple expansion. For high-speed expansion using a Carry Lookahead Generator, refer to the 74F381 data sheet.

### Features

- Performs six arithmetic and logic functions
- Selectable LOW (clear) and HIGH (preset) functions
- LOW input loading minimizes drive requirements
- Carry output for ripple expansion
- Overflow output for twos complement arithmetic

### Ordering Code:

Order Number	Package Number	Package Description
74F382SC	M20B	20-Lead Small Outline Integrated Circuit (SOIC), JEDEC MS-013, 0.300 Wide
74F382SJ	M20D	20-Lead Small Outline Package (SOP), EIAJ TYPE II, 5.3mm Wide
74F382PC	N20A	20-Lead Plastic Dual-In-Line Package (PDIP), JEDEC MS-001, 0.300 Wide

Devices also available in Tape and Reel. Specify by appending the suffix letter "X" to the ordering code.

### Logic Symbols

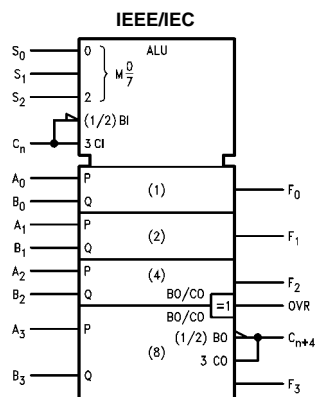
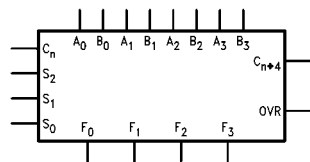

### Connection Diagram

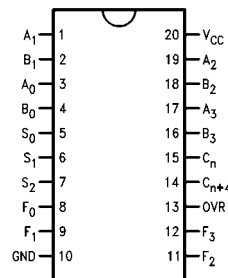

## Unit Loading/Fan Out

Pin Names	Description	U.L. HIGH/LOW	Input $I_{IH}/I_{IL}$ Output $I_{OH}/I_{OL}$
$A_0-A_3$	A Operand Inputs	1.0/4.0	20 $\mu A$ / -2.4 mA
$B_0-B_3$	B Operand Inputs	1.0/4.0	20 $\mu A$ / -2.4 mA
$S_0-S_2$	Function Select Inputs	1.0/1.0	20 $\mu A$ / -0.6 mA
$C_n$	Carry Input	1.0/5.0	20 $\mu A$ / -3.0 mA
$C_{n+4}$	Carry Output	50/33.3	-1 mA / 20 mA
OVR	Overflow Output	50/33.3	-1 mA / 20 mA
$F_0-F_3$	Function Outputs	50/33.3	-1 mA / 20 mA

## Functional Description

Signals applied to the Select inputs  $S_0-S_2$  determine the mode of operation, as indicated in the Function Select Table. An extensive listing of input and output levels is shown in the Truth Table. The circuit performs the arithmetic functions for either active HIGH or active LOW operands, with output levels in the same convention. In the Subtract operating modes, it is necessary to force a carry (HIGH for active HIGH operands, LOW for active LOW operands) into the  $C_n$  input of the least significant package. Ripple expansion is illustrated in Figure 2. The overflow output OVR is the Exclusive-OR of  $C_{n+3}$  and  $C_{n+4}$ ; a HIGH signal on OVR indicates overflow in twos complement operation. Typical delays for Figure 2 are given in Figure 1.

## Function Select Table

Select			Operation
$S_0$	$S_1$	$S_2$	
L	L	L	Clear
H	L	L	B Minus A
L	H	L	A Minus B
H	H	L	A Plus B
L	L	H	$A \oplus B$
H	L	H	A + B
L	H	H	AB
H	H	H	Preset

H = HIGH Voltage Level  
L = LOW Voltage Level

Path Segment	Toward F	Output $C_{n+4}, OVR$
$A_1$ or $B_1$ to $C_{n+4}$	6.5 ns	6.5 ns
$C_n$ to $C_{n+4}$	6.3 ns	6.3 ns
$C_n$ to $C_{n+4}$	6.3 ns	6.3 ns
$C_n$ to F	8.1 ns	—
$C_n$ to $C_{n+4}, OVR$	—	8.0 ns
Total Delay	27.2 ns	27.1 ns

FIGURE 1. 16-Bit Delay Tabulation

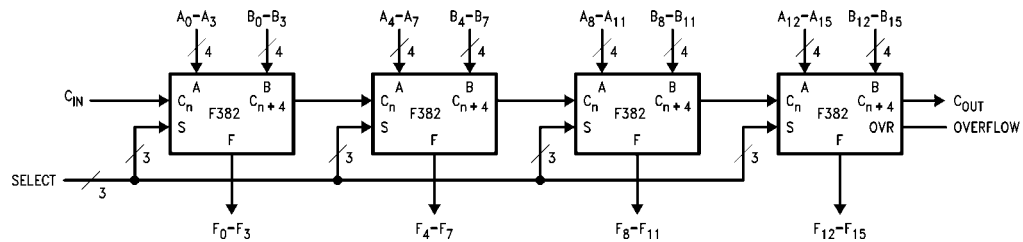

FIGURE 2. 16-Bit Ripple Carry ALU Expansion

Truth Table

Function	Inputs						Outputs						
	S <sub>0</sub>	S <sub>1</sub>	S <sub>2</sub>	C <sub>n</sub>	A <sub>n</sub>	B <sub>n</sub>	F <sub>0</sub>	F <sub>1</sub>	F <sub>2</sub>	F <sub>3</sub>	OVR	C <sub>n+4</sub>	
CLEAR	L	L	L	L	X	X	L	L	L	L	H	H	
					H	X	L	L	L	L	H	H	
B MINUS A	H	L	L	L	L	L	H	H	H	H	L	L	
				L	L	H	L	H	H	H	L	H	
				L	H	L	L	L	L	L	L	L	L
				L	H	H	H	H	H	H	H	L	L
				H	L	L	L	L	L	L	L	L	H
				H	L	H	H	H	H	H	H	L	H
				H	H	L	L	L	L	L	L	L	L
				H	H	H	H	H	L	L	L	L	L
A MINUS B	L	H	L	L	L	L	H	H	H	H	L	L	
				L	L	H	L	L	L	L	L	L	L
				L	H	L	L	H	H	H	H	L	H
				L	H	H	H	H	H	H	H	L	L
				H	L	L	L	L	L	L	L	L	H
				H	L	H	H	L	L	L	L	L	L
				H	H	L	L	H	H	H	H	L	H
				H	H	H	H	L	L	L	L	L	L
A PLUS B	H	H	L	L	L	L	L	L	L	L	L	L	
				L	L	H	H	H	H	H	L	L	
				L	H	L	H	H	H	H	L	L	
				L	H	H	L	H	H	H	L	H	
				H	L	L	L	L	L	L	L	L	
				H	L	H	H	L	L	L	L	L	H
				H	H	L	L	L	L	L	L	L	H
				H	H	H	H	H	H	H	H	L	H
A ⊕ B	L	L	H	X	L	L	L	L	L	L	L	L	
				X	L	H	H	H	H	H	L	L	
				L	H	L	H	H	H	H	L	L	
				X	H	H	L	L	L	L	H	H	
				H	H	L	H	H	H	H	H	H	
A + B	H	L	H	X	L	L	L	L	L	L	L	L	
				X	L	H	H	H	H	H	L	L	
				X	H	L	H	H	H	H	L	L	
				L	H	H	H	H	H	H	L	L	
				H	H	H	H	H	H	H	H	H	
AB	L	H	H	X	L	L	L	L	L	L	H	H	
				X	L	H	L	L	L	L	L	L	
				X	H	L	L	L	L	L	H	H	
				L	H	H	H	H	H	H	L	L	
				H	H	H	H	H	H	H	H	H	
PRESET	H	H	H	X	L	L	H	H	H	H	L	L	
				X	L	H	H	H	H	H	L	L	
				X	H	L	H	H	H	H	L	L	
				L	H	H	H	H	H	H	L	L	
				H	H	H	H	H	H	H	H	H	

H = HIGH Voltage Level

L = LOW Voltage Level

X = Immaterial

## Logic Diagram

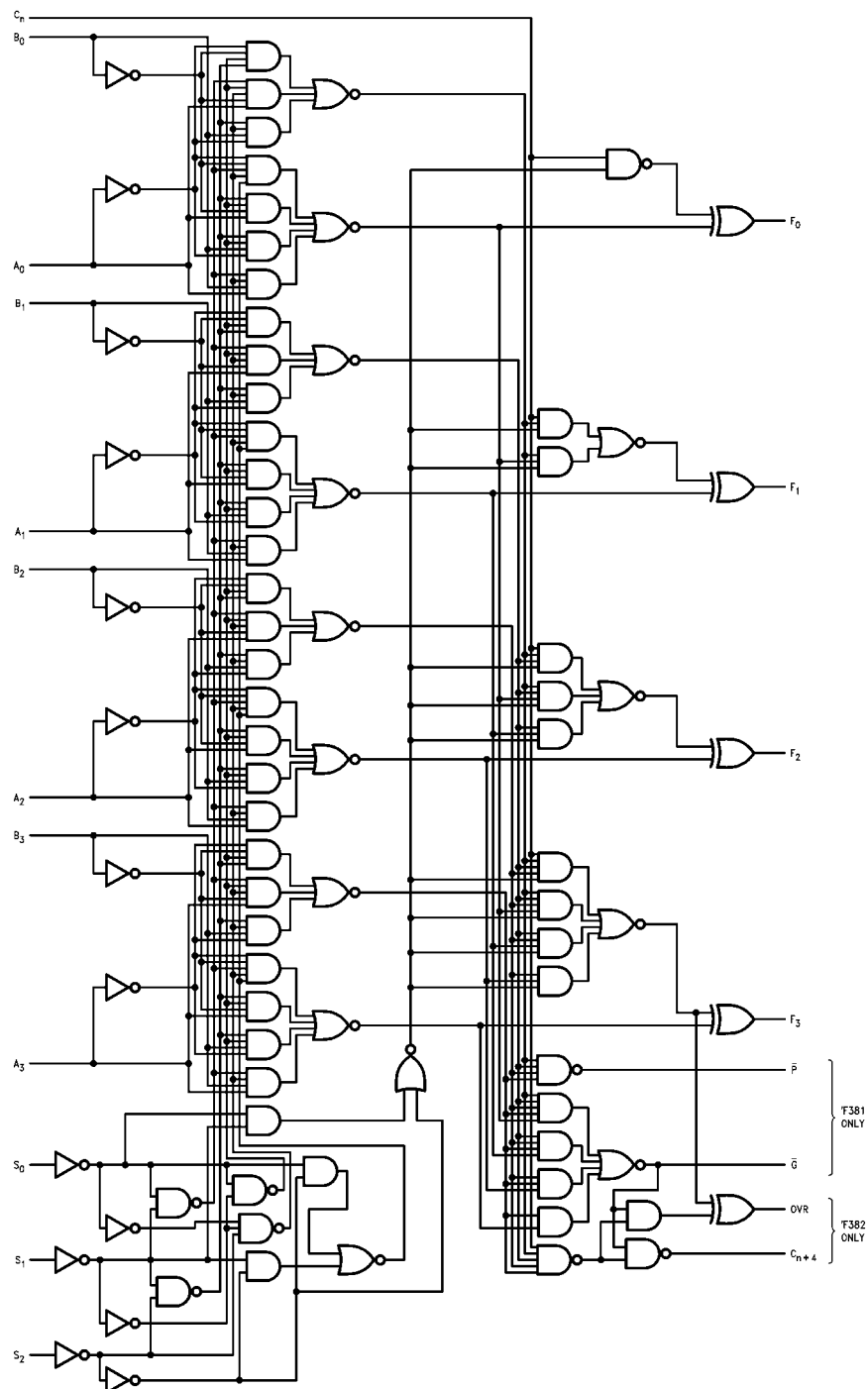

Please note that this diagram is provided only for the understanding of logic operations and should not be used to estimate propagation delays.

**Absolute Maximum Ratings**(Note 1)

Storage Temperature	-65°C to +150°C
Ambient Temperature under Bias	-55°C to +125°C
Junction Temperature under Bias	-55°C to +150°C
V <sub>CC</sub> Pin Potential to Ground Pin	-0.5V to +7.0V
Input Voltage (Note 2)	-0.5V to +7.0V
Input Current (Note 2)	-30 mA to +5.0 mA

Voltage Applied to Output

in HIGH State (with V<sub>CC</sub> = 0V)Standard Output -0.5V to V<sub>CC</sub>

3-STATE Output -0.5V to +5.5V

Current Applied to Output

in LOW State (Max) twice the rated I<sub>OL</sub> (mA)**Recommended Operating Conditions**

Free Air Ambient Temperature	0°C to +70°C
Supply Voltage	+4.5V to +5.5V

**Note 1:** Absolute maximum ratings are values beyond which the device may be damaged or have its useful life impaired. Functional operation under these conditions is not implied.

**Note 2:** Either voltage limit or current limit is sufficient to protect inputs.

**DC Electrical Characteristics** over Operating Temperature Range unless otherwise specified

Symbol	Parameter	Min	Typ	Max	Units	V <sub>CC</sub>	Conditions
V <sub>IH</sub>	Input HIGH Voltage	2.0			V		Recognized as a HIGH Signal
V <sub>IL</sub>	Input LOW Voltage			0.8	V		Recognized as a LOW Signal
V <sub>CD</sub>	Input Clamp Diode Voltage			-1.2	V	Min	I <sub>IN</sub> = -18 mA
V <sub>OH</sub>	Output HIGH Voltage	10% V <sub>CC</sub> 5% V <sub>CC</sub>	2.5 2.7		V	Min	I <sub>OH</sub> = -1 mA I <sub>OH</sub> = -1 mA
V <sub>OL</sub>	Output LOW Voltage	10% V <sub>CC</sub>		0.5	V	Min	I <sub>OL</sub> = 20 mA
I <sub>IH</sub>	Input HIGH Current			5.0	μA	Max	V <sub>IN</sub> = 2.7V
I <sub>BVI</sub>	Input HIGH Current Breakdown Test			7.0	μA	Max	V <sub>IN</sub> = 7.0V
I <sub>CEx</sub>	Output HIGH Leakage Current			50	μA	Max	V <sub>OUT</sub> = V <sub>CC</sub>
V <sub>ID</sub>	Input Leakage Test	4.75			V	0.0	I <sub>ID</sub> = 1.9 μA All Other Pins Grounded
I <sub>OD</sub>	Output Leakage Circuit Current			3.75	μA	0.0	V <sub>IOD</sub> = 150 mV All Other Pins Grounded
I <sub>IL</sub>	Input LOW Current			-0.6 -2.4 -3.0	mA	Max	V <sub>IN</sub> = 0.5V (S <sub>0</sub> - S <sub>2</sub> ) V <sub>IN</sub> = 0.5V (A <sub>0</sub> - A <sub>3</sub> , B <sub>0</sub> - B <sub>3</sub> ) V <sub>IN</sub> = 0.5V (C <sub>n</sub> )
I <sub>OS</sub>	Output Short-Circuit Current	-60		-150	mA	Max	V <sub>OUT</sub> = 0V
I <sub>CC</sub>	Power Supply Current		54	81	mA	Max	

## AC Electrical Characteristics

Symbol	Parameter	$T_A = +25^\circ\text{C}$			$T_A = 0^\circ\text{C to } +70^\circ\text{C}$		Units
		$V_{CC} = +5.0\text{V}$			$V_{CC} = +5.0\text{V}$		
		$C_L = 50\text{ pF}$			$C_L = 50\text{ pF}$		
		Min	Typ	Max	Min	Max	
$t_{PLH}$	Propagation Delay	3.0	8.1	12.0	3.0	13.0	ns
$t_{PHL}$	$C_n$ to $F_i$	2.5	5.7	8.0	2.5	9.0	
$t_{PLH}$	Propagation Delay	4.0	10.4	15.0	3.5	17.0	ns
$t_{PHL}$	Any A or B to Any F	3.0	8.2	11.0	2.5	12.0	
$t_{PLH}$	Propagation Delay	6.5	11.0	20.5	5.5	21.5	ns
$t_{PHL}$	$S_i$ to $F_i$	4.0	8.2	15.0	4.0	17.5	
$t_{PLH}$	Propagation Delay	3.5	6.0	8.5	3.5	11.0	ns
$t_{PHL}$	$A_i$ or $B_i$ to $C_{n+4}$	3.5	6.5	9.0	3.5	10.5	
$t_{PLH}$	Propagation Delay	7.0	12.5	16.5	7.0	17.5	ns
$t_{PHL}$	$S_i$ to OVR or $C_{n+4}$	5.0	9.0	12.0	5.0	14.5	
$t_{PLH}$	Propagation Delay	2.5	5.6	8.0	2.0	9.0	ns
$t_{PHL}$	$C_n$ to $C_{n+4}$	3.5	6.3	9.0	2.0	10.0	
$t_{PLH}$	Propagation Delay	3.5	8.0	11.0	3.5	13.0	ns
$t_{PHL}$	$C_n$ to OVR	2.5	7.1	10.0	2.5	11.0	
$t_{PLH}$	Propagation Delay	7.0	11.5	15.5	7.0	16.5	ns
$t_{PHL}$	$A_i$ or $B_i$ to OVR	3.0	8.0	10.5	3.0	11.5	

**Physical Dimensions** inches (millimeters) unless otherwise noted

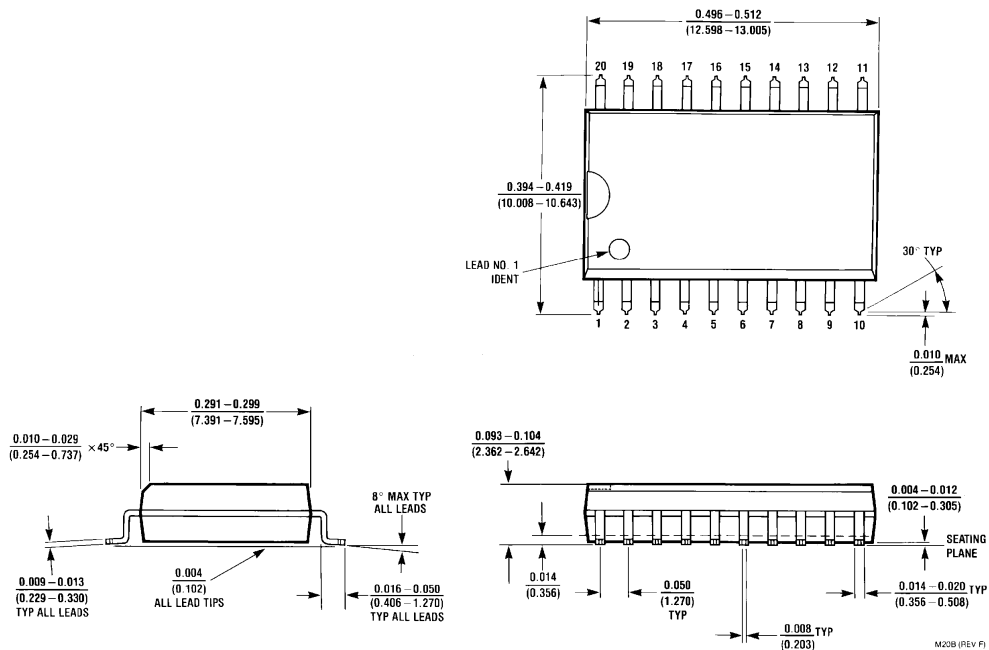

**20-Lead Small Outline Integrated Circuit (SOIC), JEDEC MS-013, 0.300 Wide Package Number M20B**

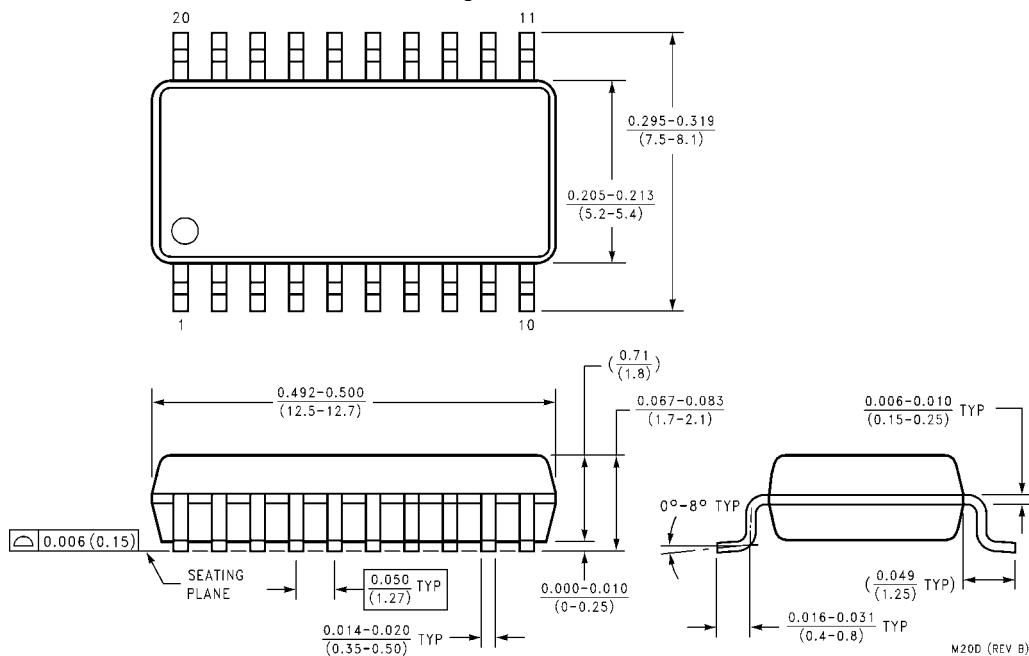

**20-Lead Small Outline Package (SOP), EIAJ TYPE II, 5.3mm Wide Package Number M20D**

**Physical Dimensions** inches (millimeters) unless otherwise noted (Continued)

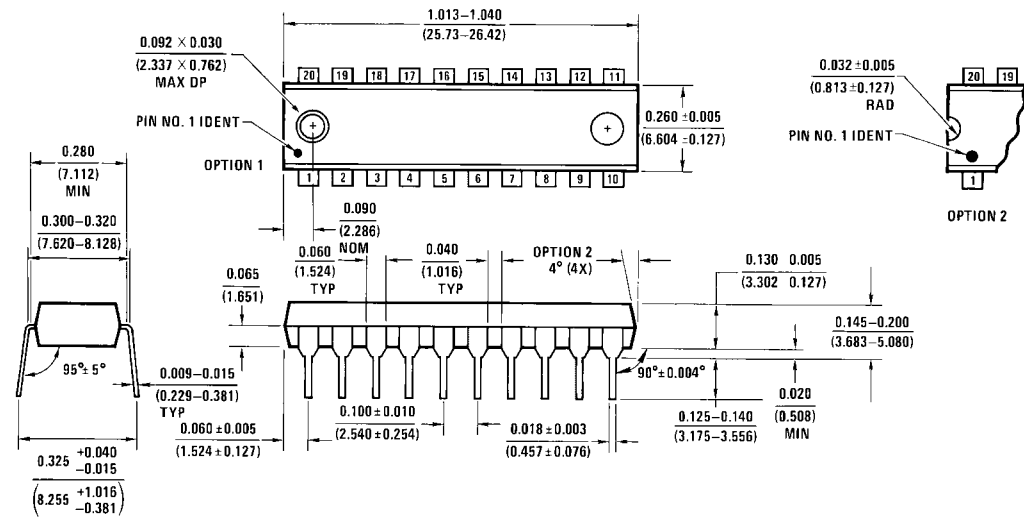

**20-Lead Plastic Dual-In-Line Package (PDIP), JEDEC MS-001, 0.300 Wide Package Number N20A**

Fairchild does not assume any responsibility for use of any circuitry described, no circuit patent licenses are implied and Fairchild reserves the right at any time without notice to change said circuitry and specifications.

**LIFE SUPPORT POLICY**

FAIRCHILD'S PRODUCTS ARE NOT AUTHORIZED FOR USE AS CRITICAL COMPONENTS IN LIFE SUPPORT DEVICES OR SYSTEMS WITHOUT THE EXPRESS WRITTEN APPROVAL OF THE PRESIDENT OF FAIRCHILD SEMICONDUCTOR CORPORATION. As used herein:

1. Life support devices or systems are devices or systems which, (a) are intended for surgical implant into the body, or (b) support or sustain life, and (c) whose failure to perform when properly used in accordance with instructions for use provided in the labeling, can be reasonably expected to result in a significant injury to the user.
2. A critical component in any component of a life support device or system whose failure to perform can be reasonably expected to cause the failure of the life support device or system, or to affect its safety or effectiveness.

[www.fairchildsemi.com](http://www.fairchildsemi.com)