

PS21963/-A/-C

TRANSFER-MOLD TYPE
INSULATED TYPE

PS21963-A



INTEGRATED POWER FUNCTIONS

600V/10A low-loss 5th generation IGBT inverter bridge for three phase DC-to-AC power conversion

INTEGRATED DRIVE, PROTECTION AND SYSTEM CONTROL FUNCTIONS

- For upper-leg IGBTs : Drive circuit, High voltage isolated high-speed level shifting, Control supply under-voltage (UV) protection.
- For lower-leg IGBTs : Drive circuit, Control supply under-voltage protection (UV), Short circuit protection (SC).
- Fault signaling : Corresponding to an SC fault (Lower-leg IGBT) or a UV fault (Lower-side supply).
- Input interface : 3V, 5V line (High Active).

APPLICATION

AC100V~200V three-phase inverter drive for small power motor control.

Fig. 1 PACKAGE OUTLINES (PS21963)

Dimensions in mm

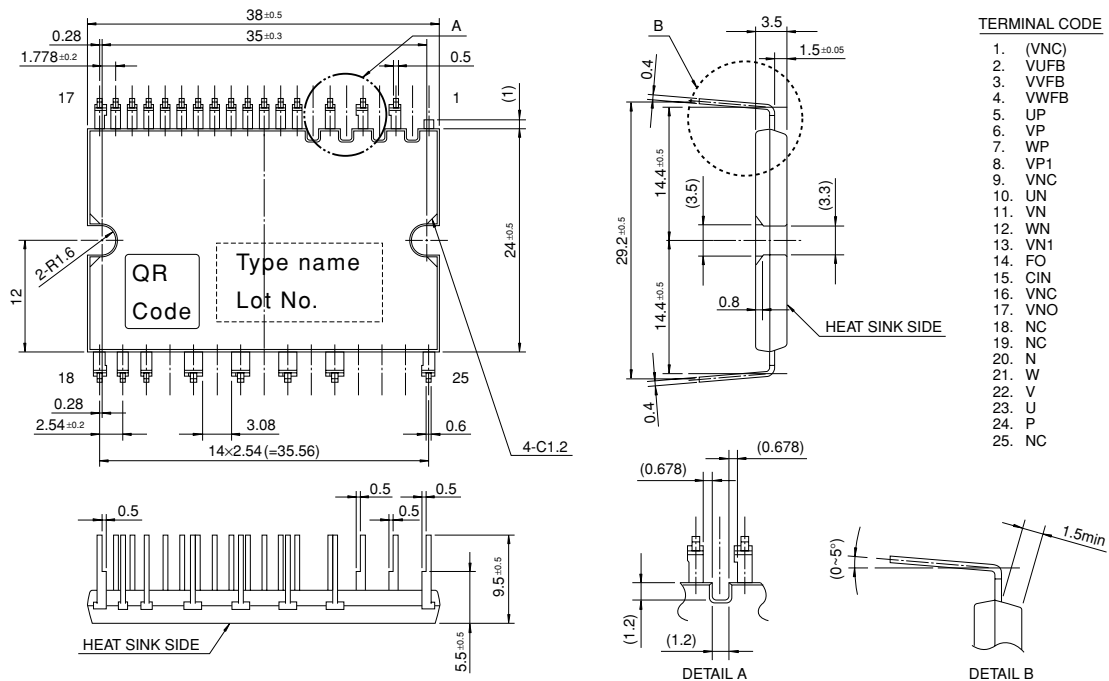

PS21963/-A/-C

TRANSFER-MOLD TYPE
INSULATED TYPE

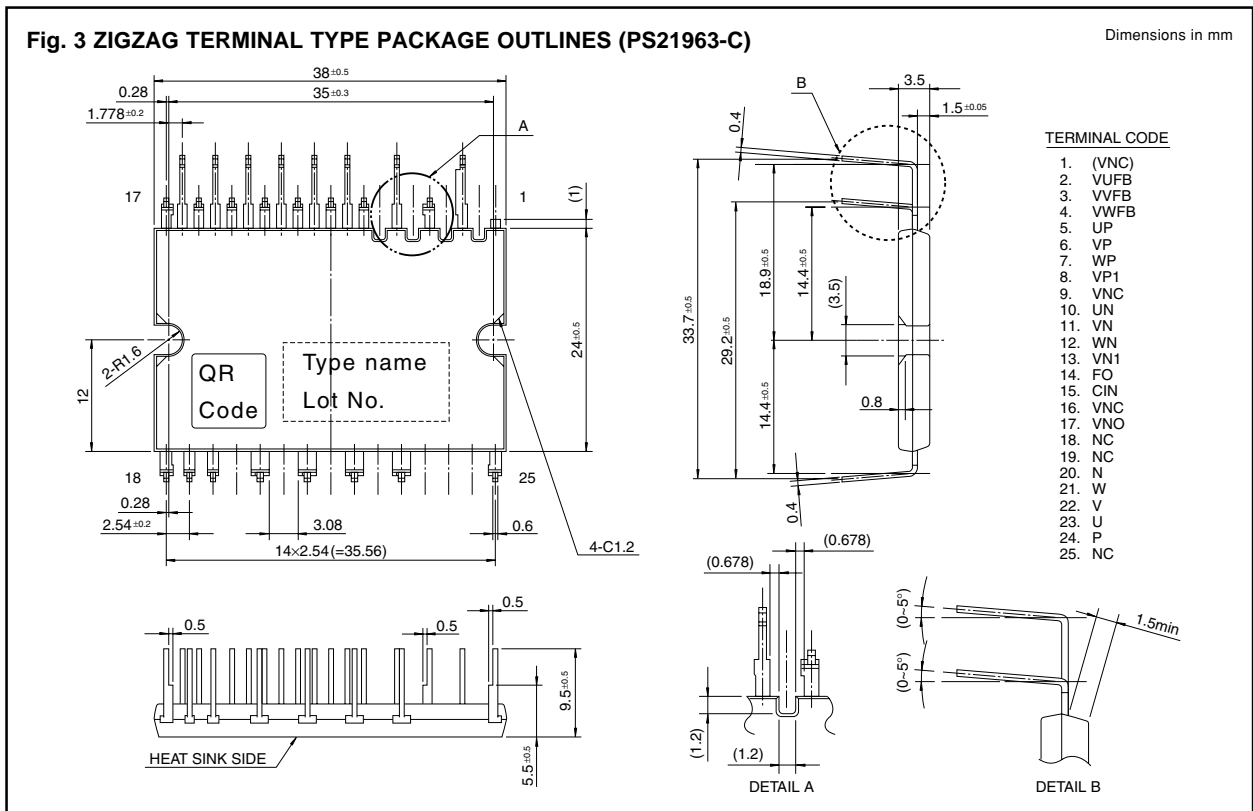
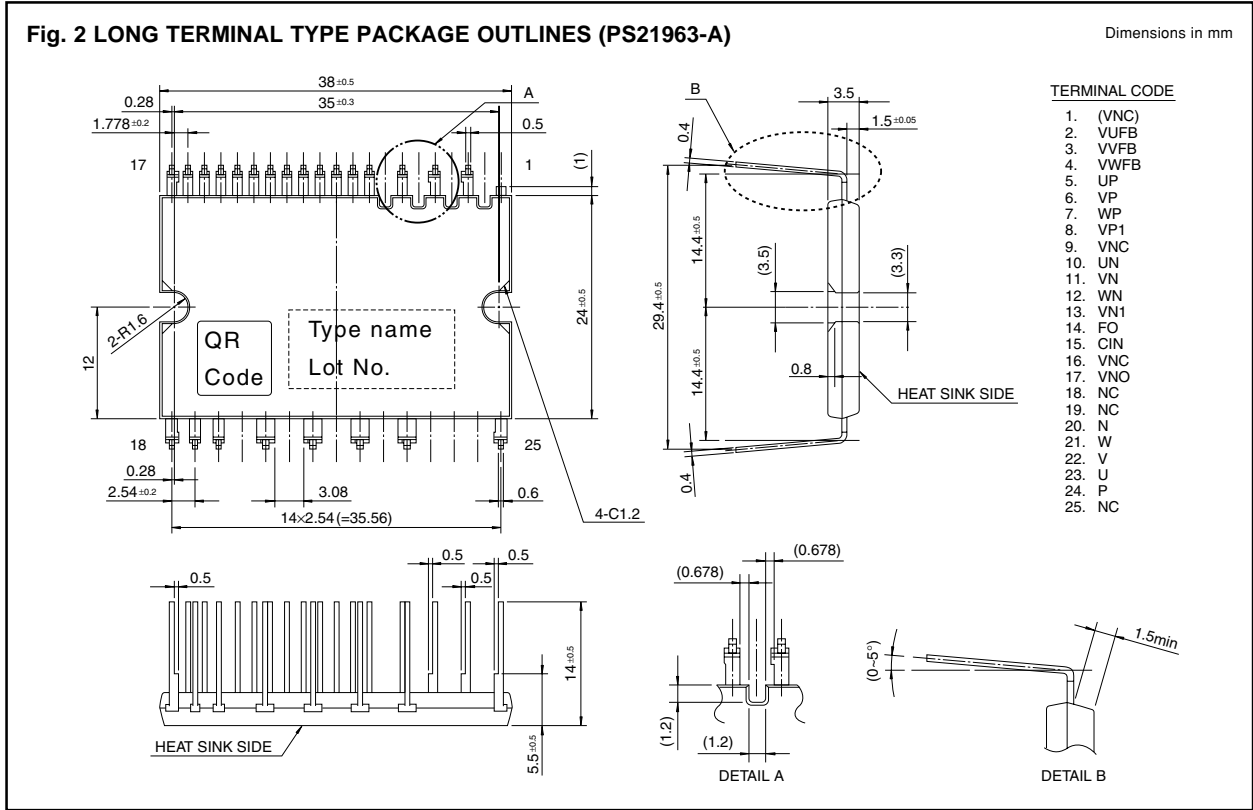

Fig. 4 INTERNAL FUNCTIONS BLOCK DIAGRAM (TYPICAL APPLICATION EXAMPLE)

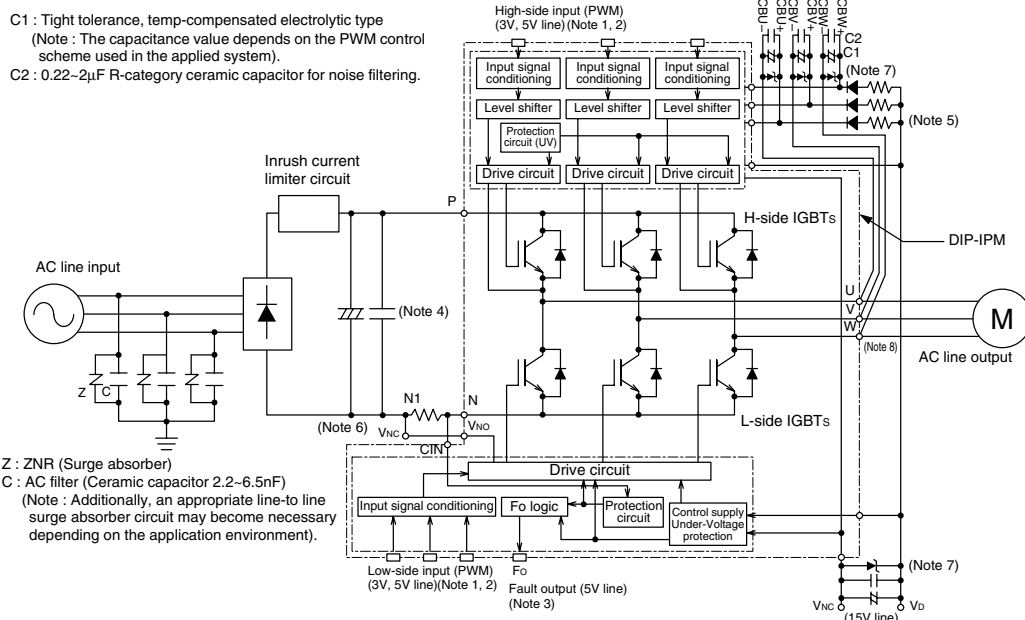
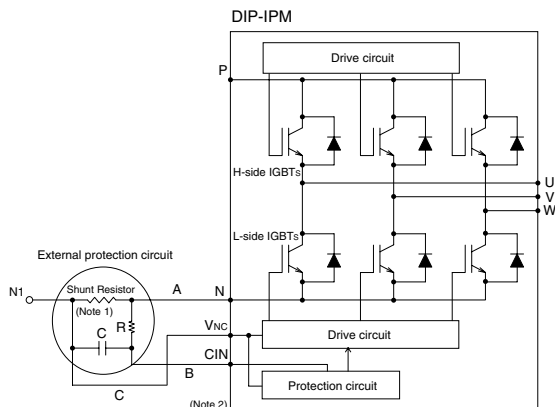
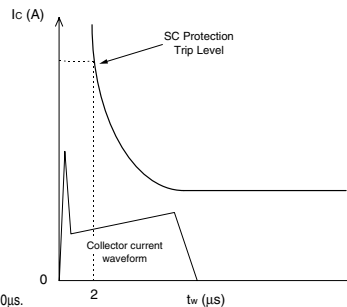

Fig. 5 EXTERNAL PART OF THE DIP-IPM PROTECTION CIRCUIT



Short Circuit Protective Function (SC) :

SC protection is achieved by sensing the L-side DC-Bus current (through the external shunt resistor) after allowing a suitable filtering time (defined by the RC circuit). When the sensed shunt voltage exceeds the SC trip-level, all the L-side IGBTs are turned OFF and a fault signal (Fo) is output. Since the SC fault may be repetitive, it is recommended to stop the system when the Fo signal is received and check the fault.



PS21963/-A/-C

TRANSFER-MOLD TYPE
INSULATED TYPE

MAXIMUM RATINGS ($T_j = 25^\circ\text{C}$, unless otherwise noted)

INVERTER PART

Symbol	Parameter	Condition	Ratings	Unit
V _{CC}	Supply voltage	Applied between P-N	450	V
V _{CC(surge)}	Supply voltage (surge)	Applied between P-N	500	V
V _{CES}	Collector-emitter voltage		600	V
±I _C	Each IGBT collector current	T _C = 25°C	10	A
±I _{CP}	Each IGBT collector current (peak)	T _C = 25°C, less than 1ms	20	A
P _C	Collector dissipation	T _C = 25°C, per 1 chip	27.0	W
T _j	Junction temperature	(Note 1)	-20~+125	°C

Note 1 : The maximum junction temperature rating of the power chips integrated within the DIP-IPM is 150°C (@ T_C ≤ 100°C). However, to ensure safe operation of the DIP-IPM, the average junction temperature should be limited to T_{j(ave)} ≤ 125°C (@ T_C ≤ 100°C).

CONTROL (PROTECTION) PART

Symbol	Parameter	Condition	Ratings	Unit
V _D	Control supply voltage	Applied between VP1-VNC, VN1-VNC	20	V
V _{DB}	Control supply voltage	Applied between VUFB-U, VVFB-V, VWFB-W	20	V
V _{IN}	Input voltage	Applied between UP, VP, WP, UN, VN, WN-VNC	-0.5~V _D +0.5	V
V _{FO}	Fault output supply voltage	Applied between FO-VNC	-0.5~V _D +0.5	V
I _{FO}	Fault output current	Sink current at FO terminal	1	mA
V _{SC}	Current sensing input voltage	Applied between CIN-VNC	-0.5~V _D +0.5	V

TOTAL SYSTEM

Symbol	Parameter	Condition	Ratings	Unit
V _{CC(PROT)}	Self protection supply voltage limit (short circuit protection capability)	V _D = 13.5~16.5V, Inverter part T _j = 125°C, non-repetitive, less than 2μs	400	V
T _C	Module case operation temperature	(Note 2)	-20~+100	°C
T _{stg}	Storage temperature		-40~+125	°C
V _{iso}	Isolation voltage	60Hz, Sinusoidal, AC 1 minutes, All connected pins to heat-sink plate	1500	V _{rms}

Note 2: T_C measurement point

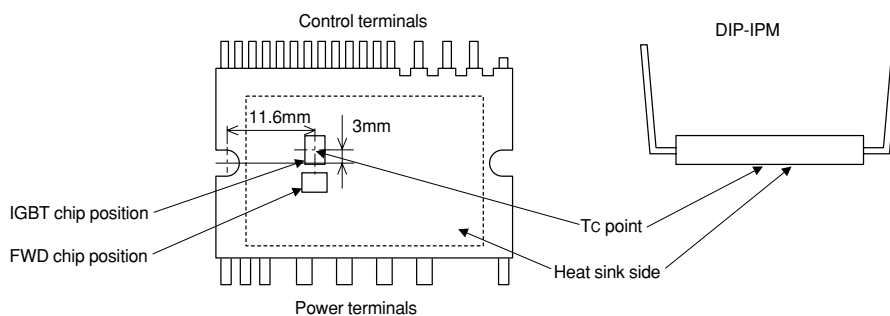

PS21963/-A/-C

**TRANSFER-MOLD TYPE
INSULATED TYPE**

THERMAL RESISTANCE

Symbol	Parameter	Condition	Limits			Unit
			Min.	Typ.	Max.	
R _{th(j-c)Q}	Junction to case thermal resistance (Note 3)	Inverter IGBT part (per 1/6 module)	—	—	3.7	°C/W
R _{th(j-c)F}		Inverter FWD part (per 1/6 module)	—	—	4.5	°C/W

Note 3 : Grease with good thermal conductivity should be applied evenly with about +100μm~+200μm on the contacting surface of DIP-IPM and heat-sink.

The contacting thermal resistance between DIP-IPM case and heat sink (R_{th(c-f)}) is determined by the thickness and the thermal conductivity of the applied grease. For reference, R_{th(c-f)} (per 1/6 module) is about 0.3°C/W when the grease thickness is 20μm and the thermal conductivity is 1.0W/m·k.

ELECTRICAL CHARACTERISTICS (T_j = 25°C, unless otherwise noted)

INVERTER PART

Symbol	Parameter	Condition	Limits			Unit
			Min.	Typ.	Max.	
V _{CE(sat)}	Collector-emitter saturation voltage	V _D = V _{DB} = 15V V _{IN} = 5V	—	1.70	2.20	V
		I _C = 10A, T _j = 25°C I _C = 10A, T _j = 125°C	—	1.80	2.30	
V _{EC}	FWD forward voltage	T _j = 25°C, -I _C = 10A, V _{IN} = 0V	—	1.70	2.20	V
t _{on}	Switching times	V _{CC} = 300V, V _D = V _{DB} = 15V I _C = 10A, T _j = 125°C, V _{IN} = 0 ↔ 5V Inductive load (upper-lower arm)	0.60	1.10	1.70	μs
t _{tr}			—	0.30	—	μs
t _{c(on)}			—	0.40	0.60	μs
t _{off}			—	1.50	2.10	μs
t _{c(off)}			—	0.50	0.80	μs
IC _{ES}			Collector-emitter cut-off current	V _{CE} = V _{CES}	—	—
		T _j = 25°C T _j = 125°C	—	—	10	

CONTROL (PROTECTION) PART

Symbol	Parameter	Condition	Limits			Unit		
			Min.	Typ.	Max.			
I _D	Circuit current	V _D = V _{DB} = 15V V _{IN} = 5V	Total of VP1-VNC, VN1-VNC		—	—	2.80	mA
			VUFB-U, VVFB-V, VWFB-W		—	—	0.55	mA
		V _D = V _{DB} = 15V V _{IN} = 0V	Total of VP1-VNC, VN1-VNC		—	—	2.80	mA
			VUFB-U, VVFB-V, VWFB-W		—	—	0.55	mA
V _{FOH}	FO output voltage	V _{SC} = 0V, FO terminal pull-up to 5V by 10kΩ	4.9	—	—	V		
V _{FOL}		V _{SC} = 1V, I _{FO} = 1mA	—	—	0.95	V		
V _{SC(ref)}	Short circuit trip level	T _j = 25°C, V _D = 15V (Note 4)	0.43	0.48	0.53	V		
I _{IN}	Input current	V _{IN} = 5V	0.70	1.00	1.50	mA		
UV _{DBt}	Control supply under-voltage protection	T _j ≤ 125°C	Trip level		10.0	—	12.0	V
UV _{DBr}			Reset level		10.5	—	12.5	V
UV _{Dt}			Trip level		10.3	—	12.5	V
UV _{Dr}			Reset level		10.8	—	13.0	V
t _{FO}	Fault output pulse width	(Note 5)	20	—	—	μs		
V _{th(on)}	ON threshold voltage	Applied between UP, VP, WP, UN, VN, WN-VNC	—	2.1	2.6	V		
V _{th(off)}	OFF threshold voltage		0.8	1.3	—	V		
V _{th(hys)}	ON/OFF threshold hysteresis voltage		0.35	0.65	—	V		

Note 4 : Short circuit protection is functioning only for the lower-arms. Please select the external shunt resistance such that the SC trip-level is less than 1.7 times of the current rating.

5 : Fault signal is asserted corresponding to a short circuit or lower side control supply under-voltage failure.

PS21963/-A/-C

TRANSFER-MOLD TYPE
INSULATED TYPE

MECHANICAL CHARACTERISTICS AND RATINGS

Parameter	Condition		Limits			Unit
			Min.	Typ.	Max.	
Mounting torque	Mounting screw : M3 (Note 6)	Recommended : 0.69 N·m	0.59	—	0.78	N·m
Weight			—	10	—	g
Heat-sink flatness	(Note 7)		-50	—	100	μm

Note 6 : Plain washers (ISO 7089~7094) are recommended.

Note 7 : Flatness measurement position

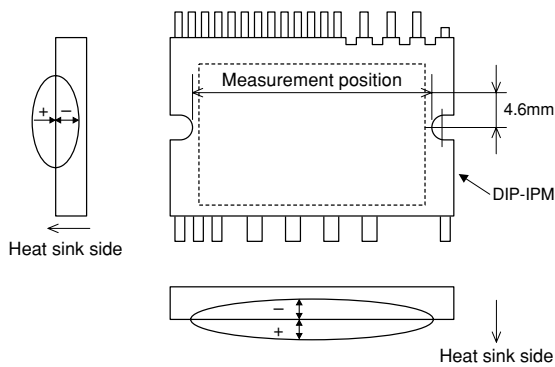

RECOMMENDED OPERATION CONDITIONS

Symbol	Parameter	Condition	Limits			Unit	
			Min.	Typ.	Max.		
VCC	Supply voltage	Applied between P-N	0	300	400	V	
VD	Control supply voltage	Applied between VP1-VNC, VN1-VNC	13.5	15.0	16.5	V	
VDB	Control supply voltage	Applied between VUFB-U, VVFB-V, VWFB-W	13.0	15.0	18.5	V	
ΔVD, ΔVDB	Control supply variation		-1	—	1	V/μs	
tdead	Arm shoot-through blocking time	For each input signal, Tc ≤ 100°C	1.5	—	—	μs	
Io	Output r.m.s. current	VCC = 300V, VD = VDB = 15V, P.F = 0.8, sinusoidal PWM, Tj ≤ 125°C, Tc ≤ 100°C (Note 8)	fPWM = 5kHz	—	—	5.0	Arms
			fPWM = 15kHz	—	—	3.0	
PWIN(on)	Allowable minimum input pulse width	(Note 9)	0.5	—	—	μs	
PWIN(off)			0.5	—	—		
VNC	VNC voltage variation	Between VNC-N (including surge)	-5.0	—	5.0	V	

Note 8 : The allowable r.m.s. current value depends on the actual application conditions.

9 : IPM might not make response if the input signal pulse width is less than the recommended minimum value.

PS21963/-A/-C

TRANSFER-MOLD TYPE
INSULATED TYPE

Fig. 6 THE DIP-IPM INTERNAL CIRCUIT

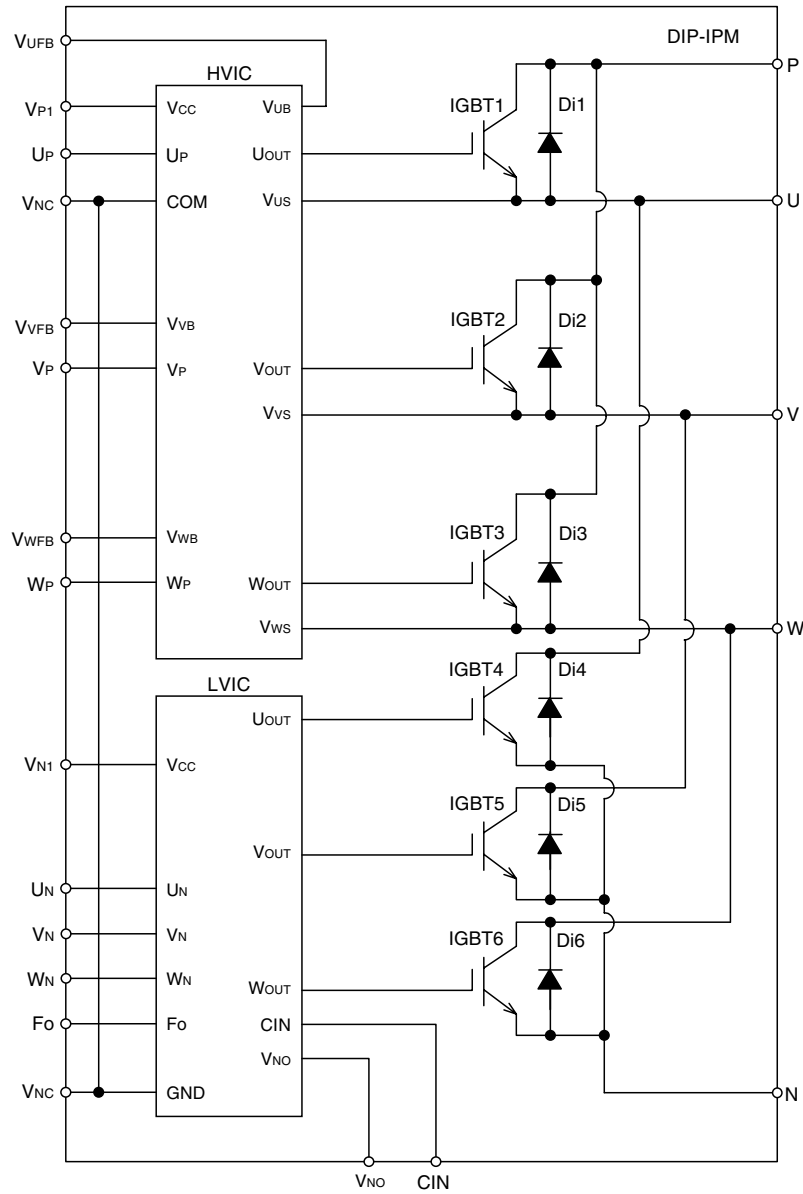
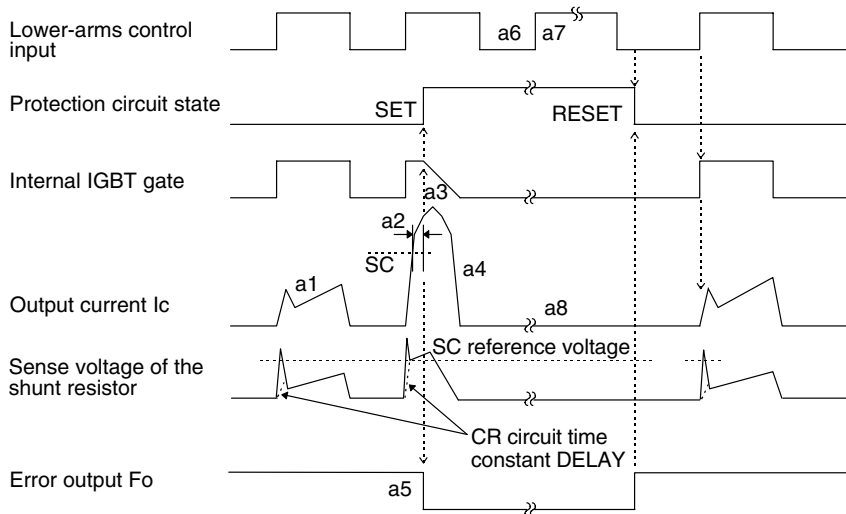

Fig. 7 TIMING CHART OF THE DIP-IPM PROTECTIVE FUNCTIONS

[A] Short-Circuit Protection (Lower-arms only with the external shunt resistor and CR filter)

- a1. Normal operation : IGBT ON and carrying current.
- a2. Short circuit detection (SC trigger).
- a3. IGBT gate hard interruption.
- a4. IGBT turns OFF.
- a5. FO timer starts ($t_{FO(min)} = 20\mu s$).
- a6. Input "L" : IGBT OFF.
- a7. Input "H".
- a8. IGBT OFF in spite of input "H".



[B] Under-Voltage Protection (Lower-side, UVb)

- b1. Control supply voltage rising : After the voltage level reaches UV_{Dr} , the circuits start to operate when next input is applied.
- b2. Normal operation : IGBT ON and carrying current.
- b3. Under voltage trip (UV_{Dt}).
- b4. IGBT OFF in spite of control input condition.
- b5. Fo output ($t_{FO} \geq 20\mu s$ and Fo output continuously during UV period).
- b6. Under voltage reset (UV_{Dr}).
- b7. Normal operation : IGBT ON and carrying current.

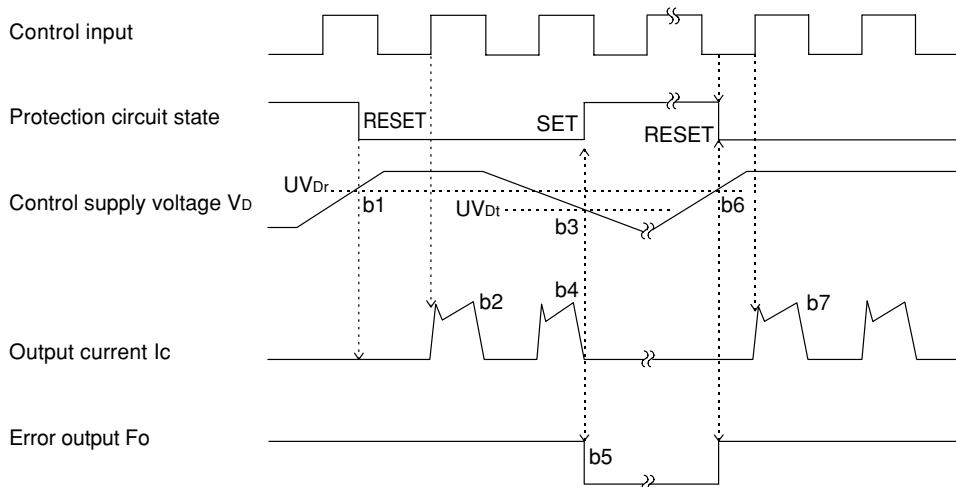

[C] Under-Voltage Protection (Upper-side, UVDB)

- c1. Control supply voltage rises : After the voltage reaches UVDBr, the circuits start to operate when next input is applied.
- c2. Normal operation : IGBT ON and carrying current.
- c3. Under voltage trip (UVDBt).
- c4. IGBT OFF in spite of control input signal level, but there is no Fo signal output.
- c5. Under voltage reset (UVDBr).
- c6. Normal operation : IGBT ON and carrying current.

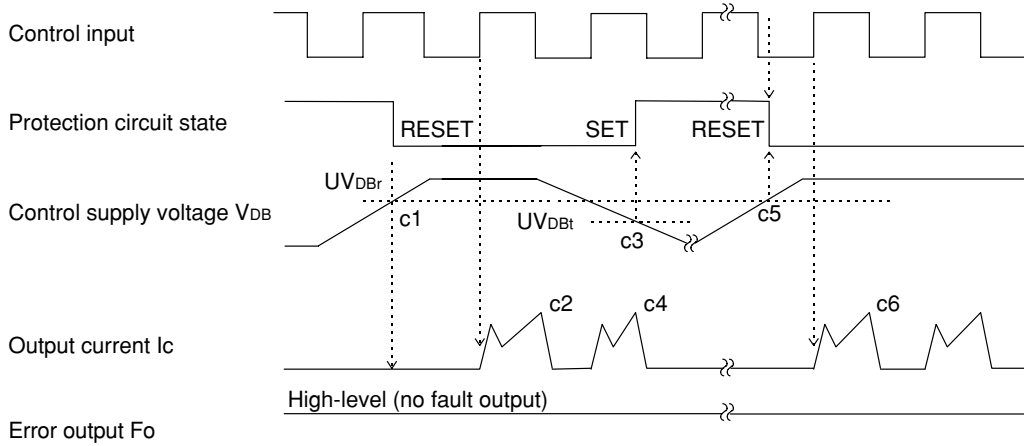
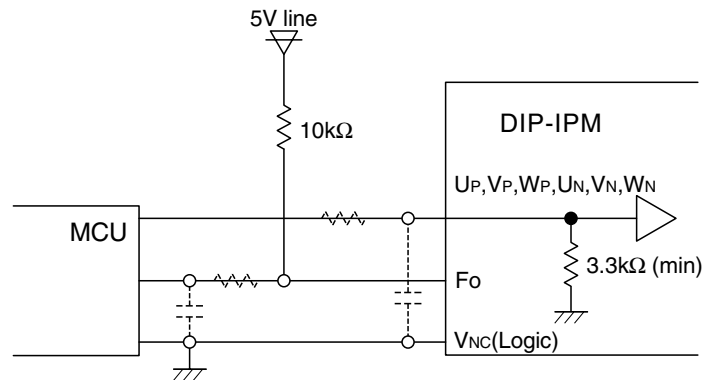

Fig. 8 RECOMMENDED MCU I/O INTERFACE CIRCUIT



Note : The setting of RC coupling at each input (parts shown dotted) depends on the PWM control scheme and the wiring impedance of the printed circuit board.
The DIP-IPM input section integrates a 3.3kΩ (min) pull-down resistor. Therefore, when using an external filtering resistor, pay attention to the turn-on threshold voltage.

Fig. 9 WIRING CONNECTION OF SHUNT RESISTOR

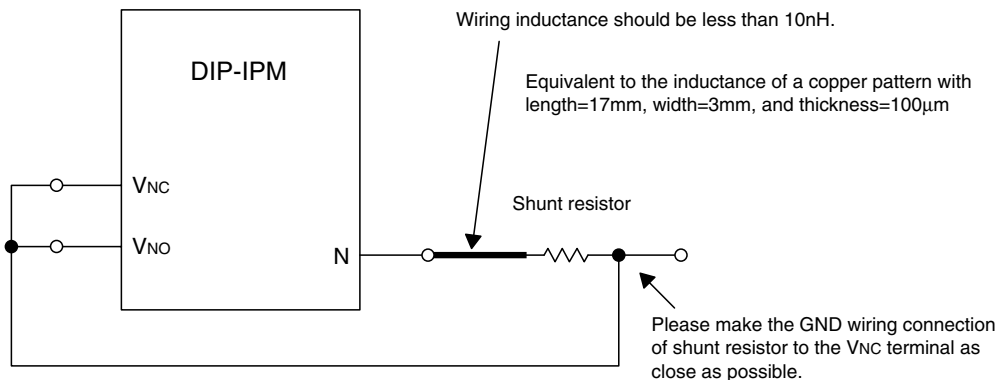
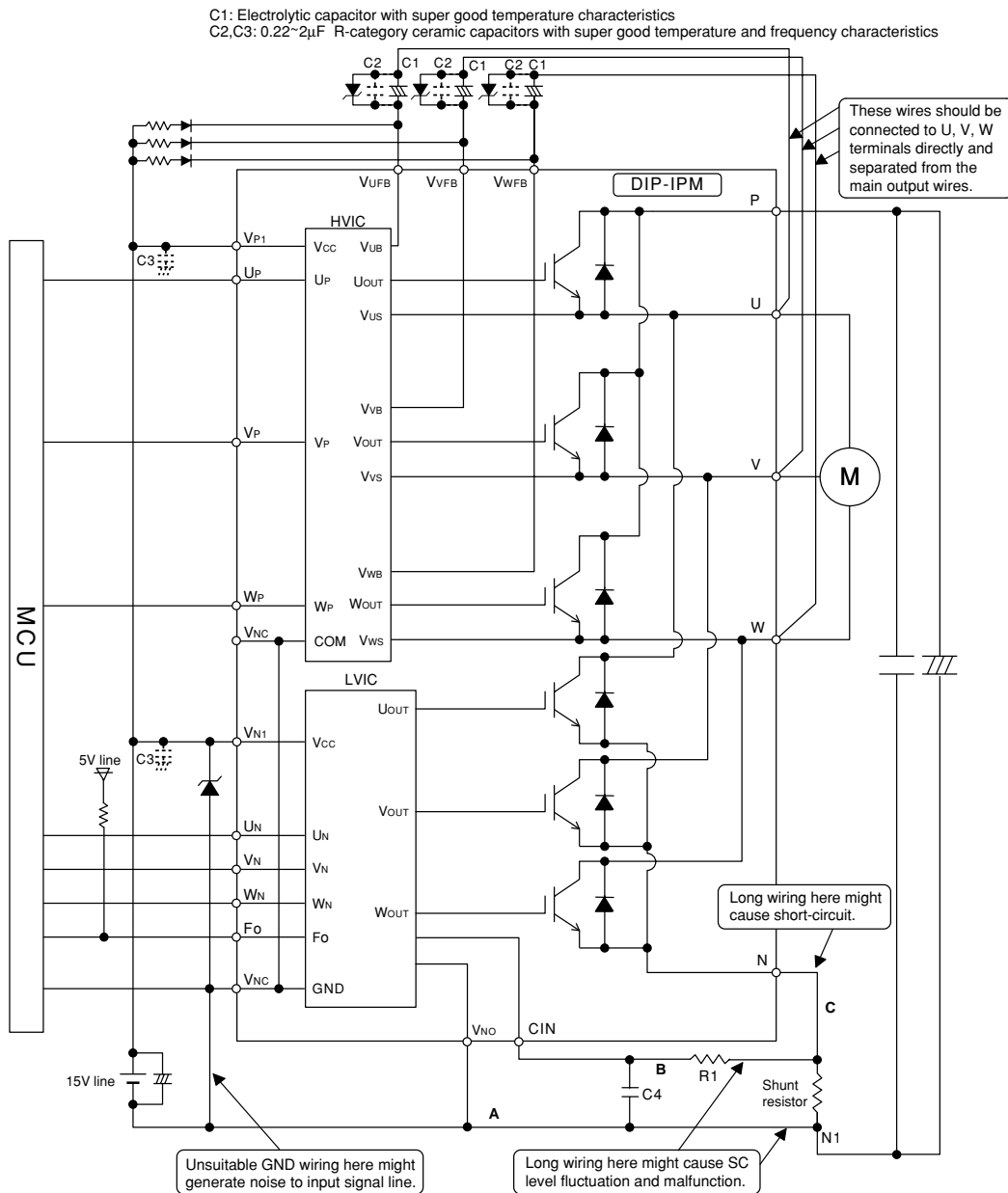

Fig. 10 AN EXAMPLE OF TYPICAL DIP-IPM APPLICATION CIRCUIT



- Note 1** : To prevent malfunction, the wiring of each input should be as short as possible (2~3cm).
- 2** : By virtue of integrating HVIC inside, direct coupling to MCU without opto-coupler or transformer isolation is possible.
- 3** : Fo output is open drain type, it should be pulled up to a 5V supply with an approximately 10kΩ resistor.
- 4** : The logic of input signal is high-active. The DIP-IPM input signal section integrates a 3.3kΩ (min) pull-down resistor. If using external filtering resistor, ensure the voltage drop of ON signal not below the threshold value.
- 5** : To prevent malfunction of protection, the wiring of A, B, C should be as short as possible.
- 6** : Please set the filter R1C4 time constant such that the IGBT can be interrupted within 2μs.
- 7** : Each capacitor should be located as nearby the pins of the DIP-IPM as possible.
- 8** : To prevent surge destruction, the wiring between the smoothing capacitor and the P&N1 pins should be as short as possible. Approximately a 0.1~0.22μF snubber capacitor between the P&N1 pins is recommended.
- 9** : Make external wiring connection between Vno and VNC terminals as shown in Fig.9.
- 10** : Two VNC terminals (9 & 16 pin) are connected inside DIP-IPM, please connect either one to the 15V power supply GND outside and leave another one open.
- 11** : It is recommended to insert a Zener diode (24V/1W) between each pair of control supply terminals to prevent surge destruction.