

GaAs SPST Switch DC - 3 GHz

SW-214

V2.00

Features

- Fast Switching Speed, 6 ns Typical
- Ultra Low DC Power Consumption
- Terminated

Guaranteed Specifications* (From -55°C to +85°C)

Frequency Range	DC-3 GHz		
Insertion Loss	DC-3 GHz	1.3	dB Max
	DC-2 GHz	1.2	dB Max
	DC-1 GHz	0.9	dB Max
	DC-0.5 GHz	0.9	dB Max
VSWR	DC-3 GHz	2.0:1	Max
	DC-2 GHz	1.7:1	Max
	DC-1 GHz	1.3:1	Max
	DC-0.5 GHz	1.3:1	Max
Isolation	DC-3 GHz	25	dB Min
	DC-2 GHz	38	dB Min
	DC-1 GHz	45	dB Min
	DC-0.5 GHz	50	dB Min

Operating Characteristics

Impedance		50 Ohms Nominal	
Switching Characteristics†			
t_{RISE} , t_{FALL}			3 ns Typ
t_{ON} , t_{OFF} (50% CTL to 90/10%RF)			6 ns Typ
Transients (In-Band)			30 mV Typ
Input Power for 1 dB Compression			
Control Voltages (Vdc)	0/-5	0/-8	
0.5-3 GHz	+27	+33	dBm Typ
0.05 GHz	+21	+26	dBm Typ
Intermodulation Intercept Point (for two-tone input power up to +13 dBm)			
Intercept Points	IP ₂	IP ₃	
0.5-3 GHz	+68	+46	dBm Typ
0.05 GHz	+62	+40	dBm Typ
Control Voltages (Complementary Logic)			
V _{IN} Low	0 to -0.2V @ 20 µA Max		
V _{IN} Hi	-5V @ 50 µA Typ to -8V @ 300 µA Max		

Environmental
MIL-STD-883 screening available.

* All specifications apply with 50 ohm impedance connected to all RF ports with 0 and -5 VDC control voltages.

† Faster switching speed can be achieved with enhanced driver waveform.

Ordering Information

Model No.	PIN	Package
SW-214	PIN	Flatpack

FP-13

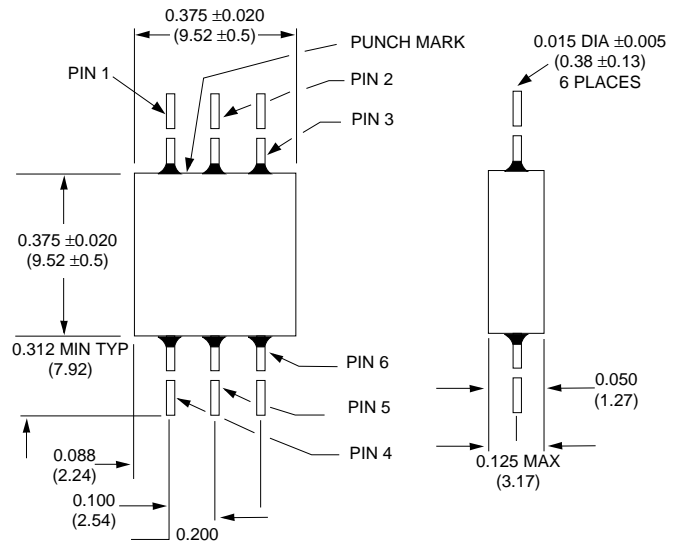

Dimensions in () are in mm.
Unless Otherwise Noted: .xxx = ±0.010 (.xx = ±0.25)
.xx = ±0.02 (.x = ±0.5)
WEIGHT (APPROX.): 0.03 OUNCES 0.8 GRAMS

Pin Configuration

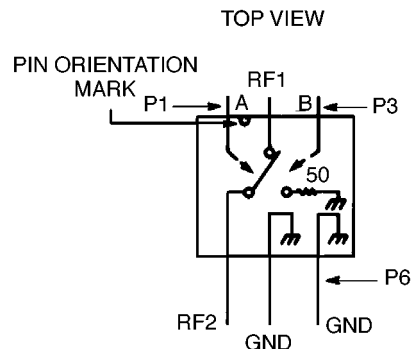

Truth Table

Control Input		Condition of Switch
A	B	RF1 to RF2
Hi	Low	ON
Low	Hi	OFF

Specifications Subject to Change Without Notice.

M/A-COM, Inc.

North America: Tel. (800) 366-2266 Fax (800) 618-8883 ■ Asia/Pacific: Tel. +81 (03) 3226-1671 Fax +81 (03) 3226-1451 ■ Europe: Tel. +44 (1344) 869 595 Fax +44 (1344) 300 020

Typical Performance

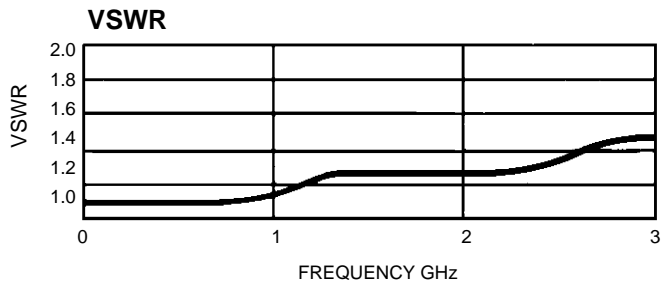
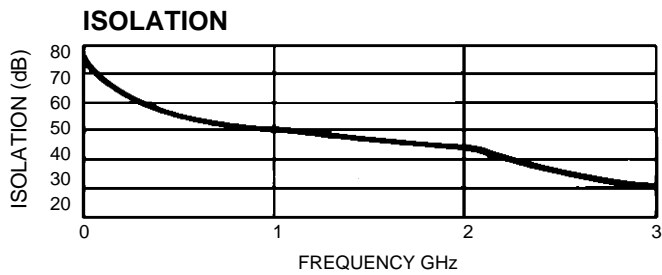
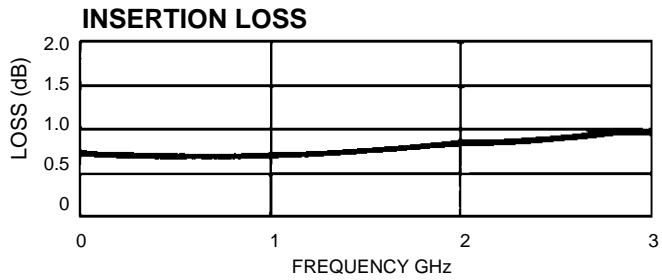

Specifications Subject to Change Without Notice.