



MX23L6410

64M-BIT (8M x 8 / 4M x 16) Mask ROM

FEATURES

- Bit organization
 - 8M x 8 (byte mode)
 - 4M x 16 (word mode)
- Fast access time
 - Random access: 90ns (max.) for 3.0V~3.6V
 - 100ns (max.) for 2.7V~3.6V

Notes: die form: 2.7~3.6V 90ns

- Current
 - Operating: 50mA (max.)
 - Standby: 15uA (max.)
- Supply voltage
 - 2.7V~3.6V
- Package
 - 44 pin SOP (500 mil)
 - 48 pin TSOP (12mm x 20mm)
 - 44 pin TSOP (Type II)

ORDER INFORMATION

Part No.	Access Time	Package
MX23L6410MC-10	100ns	44 pin SOP
MX23L6410MC-12	120ns	44 pin SOP
MX23L6410MC-15	150ns	44 pin SOP
MX23L6410TC-90	90ns	48 pin TSOP
MX23L6410TC-10	100ns	48 pin TSOP
MX23L6410TC-12	120ns	48 pin TSOP
MX23L6410TC-15	150ns	48 pin TSOP
MX23L6410RC-10	100ns	48 pin TSOP (Reverse type)
MX23L6410RC-12	120ns	48 pin TSOP (Reverse type)
MX23L6410RC-15	150ns	48 pin TSOP (Reverse type)
MX23L6410YC-10	100ns	44 pin TSOP
MX23L6410YC-12	120ns	44 pin TSOP
MX23L6410YC-15	150ns	44 pin TSOP
MX23L6410TI-10	100ns	48 pin TSOP

Note: Industrial grade temperature: -40° C~ 85° C
Commercial grade temperature: 0° C ~ 70° C

PIN CONFIGURATION

44 SOP/44 TSOP

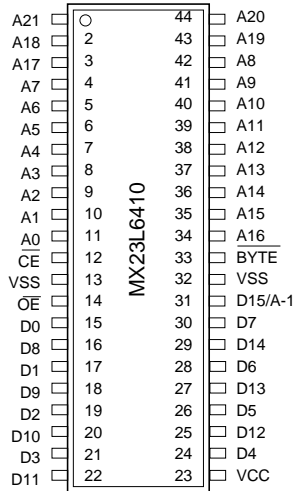

PIN DESCRIPTION

Symbol	Pin Function
A0~A21	Address Inputs
D0~D14	Data Outputs
D15/A-1	D15 (Word Mode) / LSB Address (Byte Mode)
\overline{CE}	Chip Enable Input
\overline{OE}	Output Enable Input
Byte	Word / Byte Mode Selection
VCC	Power Supply Pin
VSS	Ground Pin
NC	No Connection

48 TSOP (NORMAL TYPE)

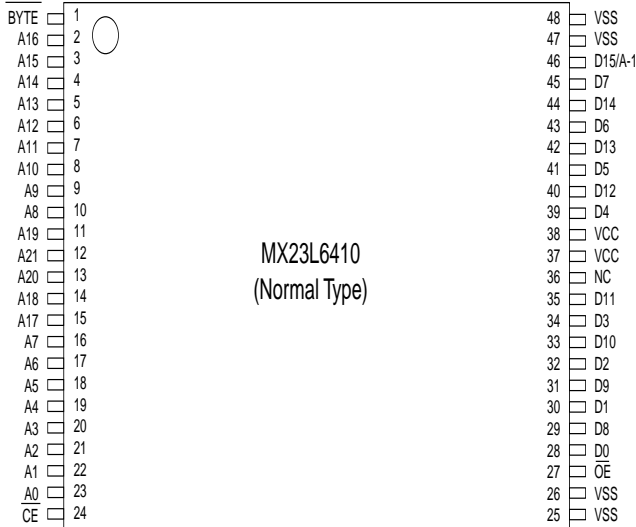

48 TSOP (REVERSE TYPE)

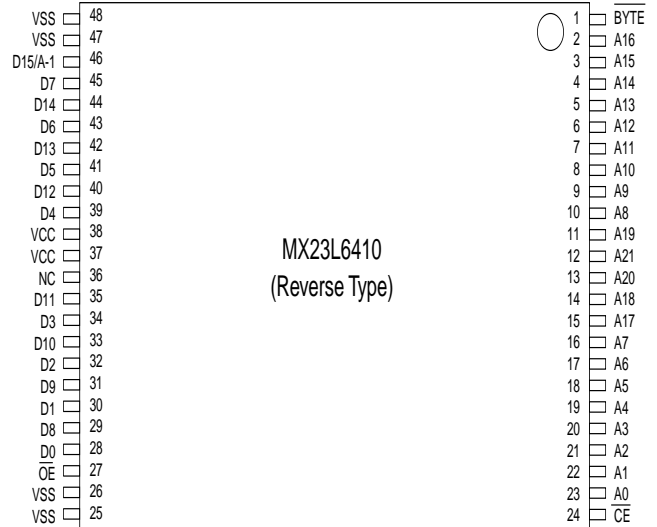

MODE SELECTION

\overline{CE}	\overline{OE}	Byte	D15/A-1	D0~D7	D8~D15	Mode	Power
H	X	X	X	High Z	High Z	-	Stand-by
L	H	X	X	High Z	High Z	-	Active
L	L	H	Output	D0~D7	D8~D15	Word	Active
L	L	L	Input	D0~D7	High Z	Byte	Active

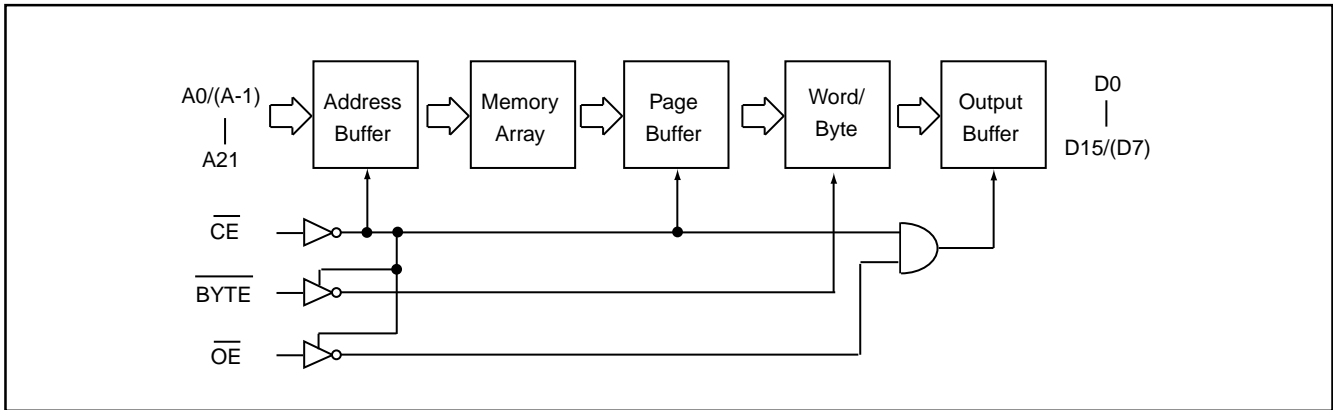
BLOCK DIAGRAM

ABSOLUTE MAXIMUM RATINGS

Item	Symbol	Ratings
Supply Voltage Relative to VSS	VCC	-0.3V to 4.3V
Voltage on any Pin Relative to VSS	VIN	-0.5V to VCC + 2V
Ambient Operating Temperature	T _{opr}	0° C to 70° C (Commercial Grade) -40° C to 85° C (Industrial Grade)
Storage Temperature	T _{stg}	-65° C to 125° C

DC CHARACTERISTICS (T_a = 0° C ~ 70° C for Commercial Grade, T_a = -40° C ~ 85° C for Industrial Grade, VCC = 2.7V~3.6V)

Item	Symbol	MIN.	MAX.	Conditions
Output High Voltage	VOH	2.4V	-	I _{OH} = -0.4mA
Output Low Voltage	VOL	-	0.4V	I _{OL} = 1.6mA
Input High Voltage	VIH	2.2V	VCC+0.3V	
Input Low Voltage	VIL	-0.3V	0.8V	
Input Leakage Current	ILI	-	5uA	0V, VCC
Output Leakage Current	ILO	-	5uA	0V, VCC
Operating Current	ICC1	-	50mA	f=5MHz, all output open
Standby Current (TTL)	ISTB1	-	1mA	\overline{CE} = VIH
Standby Current (CMOS)	ISTB2	-	15uA	\overline{CE} > VCC-0.2V
Input Capacitance	CIN	-	10pF	T _a = 25° C, f = 1MHZ
Output Capacitance	COUT	-	10pF	T _a = 25° C, f = 1MHZ

AC CHARACTERISTICS ($T_a = 0^\circ\text{C} \sim 70^\circ\text{C}$ for Commercial Grade, $T_a = -40^\circ\text{C} \sim 85^\circ\text{C}$ for Industrial Grade, $V_{CC} = 2.7\text{V} \sim 3.6\text{V}$)

Item	Symbol	23L6410-90		23L6410-10		23L6410-12		23L6410-15	
		MIN.	MAX.	MIN.	MAX.	MIN.	MAX.	MIN.	MAX.
Read Cycle Time	tRC	90ns	-	100ns	-	120ns	-	150ns	-
Address Access Time	tAA	-	90ns	-	100ns	-	120ns	-	150ns
Chip Enable Access Time	tACE	-	90ns	-	100ns	-	120ns	-	150ns
Output Enable Time	tOE	-	30ns	-	30ns	-	60ns	-	70ns
Output Hold After Address	tOH	0ns	-	0ns	-	0ns	-	0ns	-
Output High Z Delay	tHZ	-	20ns	-	20ns	-	20ns	-	20ns

Note: Output high-impedance delay (tHZ) is measured from $\overline{\text{OE}}$ or $\overline{\text{CE}}$ going high, and this parameter guaranteed by design over the full voltage and temperature operating range - not tested.

AC Test Conditions

Input Pulse Levels	0.4V~ 2.4V
Input Rise and Fall Times	10ns
Input Timing Level	1.4V
Output Timing Level	1.4V
Output Load	See Figure

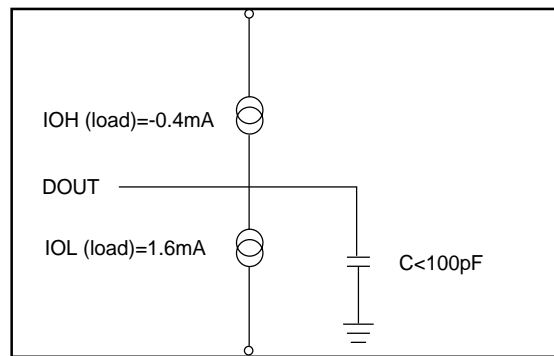

Note: No output loading is present in tester load board.

Active loading is used and under software programming control.

Output loading capacitance includes load board's and all stray capacitance.

TIMING DIAGRAM

RANDOM READ

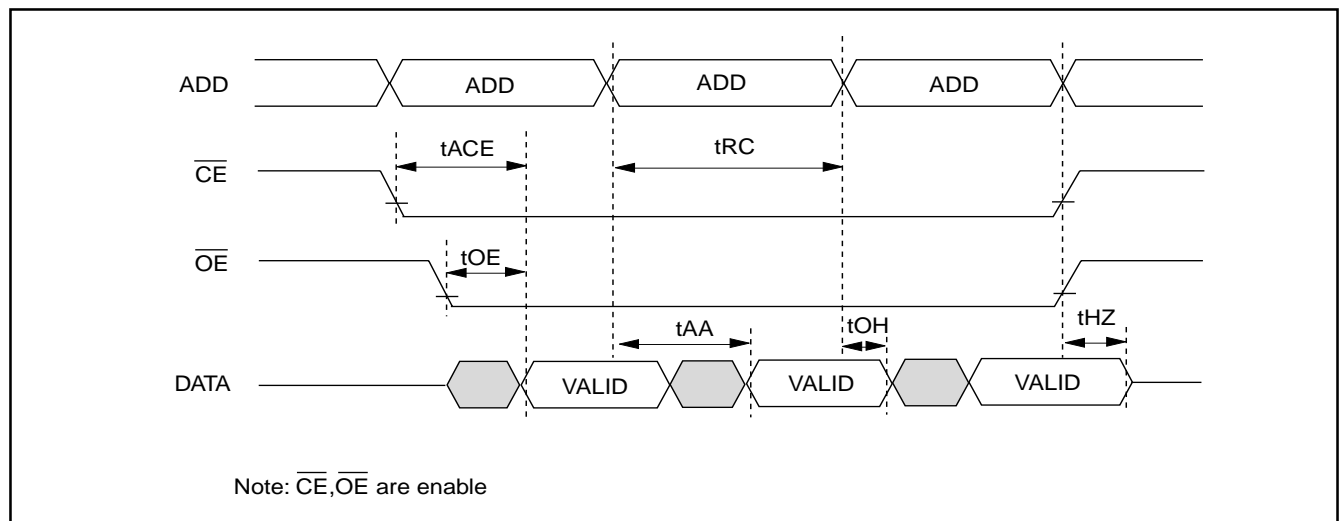

PACKAGE INFORMATION

Title: Package Outline for SOP 44L (500MIL)

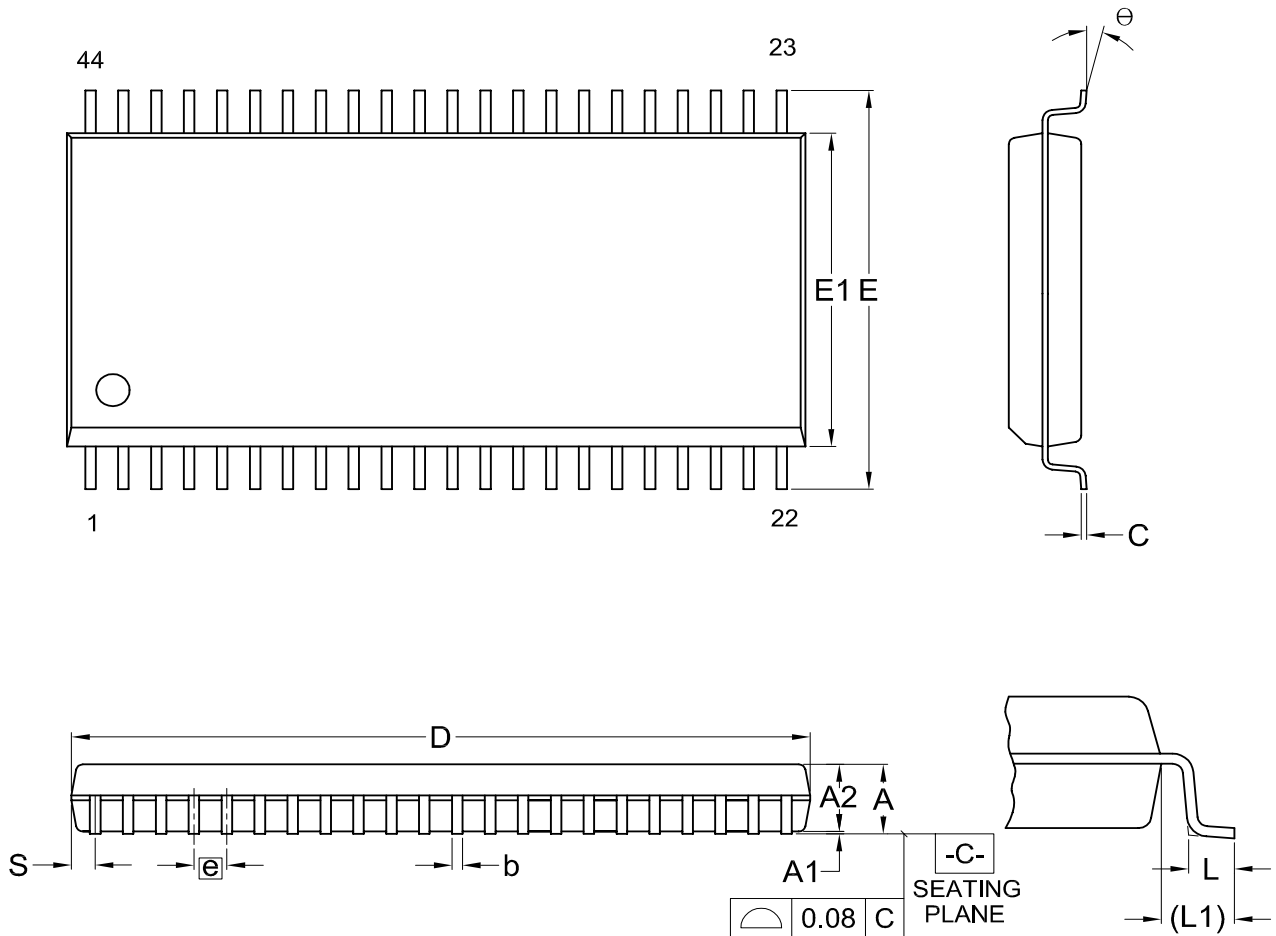

Dimensions (inch dimensions are derived from the original mm dimensions)

SYMBOL		A	A1	A2	b	C	D	E	E1	e	L	L1	S	θ
UNIT														
mm	Min.	---	0.10	2.59	0.36	0.15	28.37	15.83	12.47		0.56	1.51	0.78	0
	Nom.	---	0.15	2.69	0.41	0.20	28.50	16.03	12.60	1.27	0.76	1.71	0.91	5
	Max.	3.00	0.20	2.80	0.51	0.25	28.63	16.23	12.73		0.96	1.91	1.04	10
Inch	Min.	---	0.004	0.102	0.014	0.006	1.117	0.623	0.491		0.022	0.059	0.031	0
	Nom.	---	0.006	0.106	0.016	0.008	1.122	0.631	0.496	0.050	0.030	0.067	0.036	5
	Max.	0.118	0.008	0.110	0.020	0.010	1.127	0.639	0.501		0.038	0.075	0.041	10

DWG.NO.	REVISION	REFERENCE			ISSUE DATE
		JEDEC	EIAJ		
6110-1405	6	MO-175			11-26-'03

Title: Package Outline for TSOP(I) 48L (12X20mm)NORMAL FORM

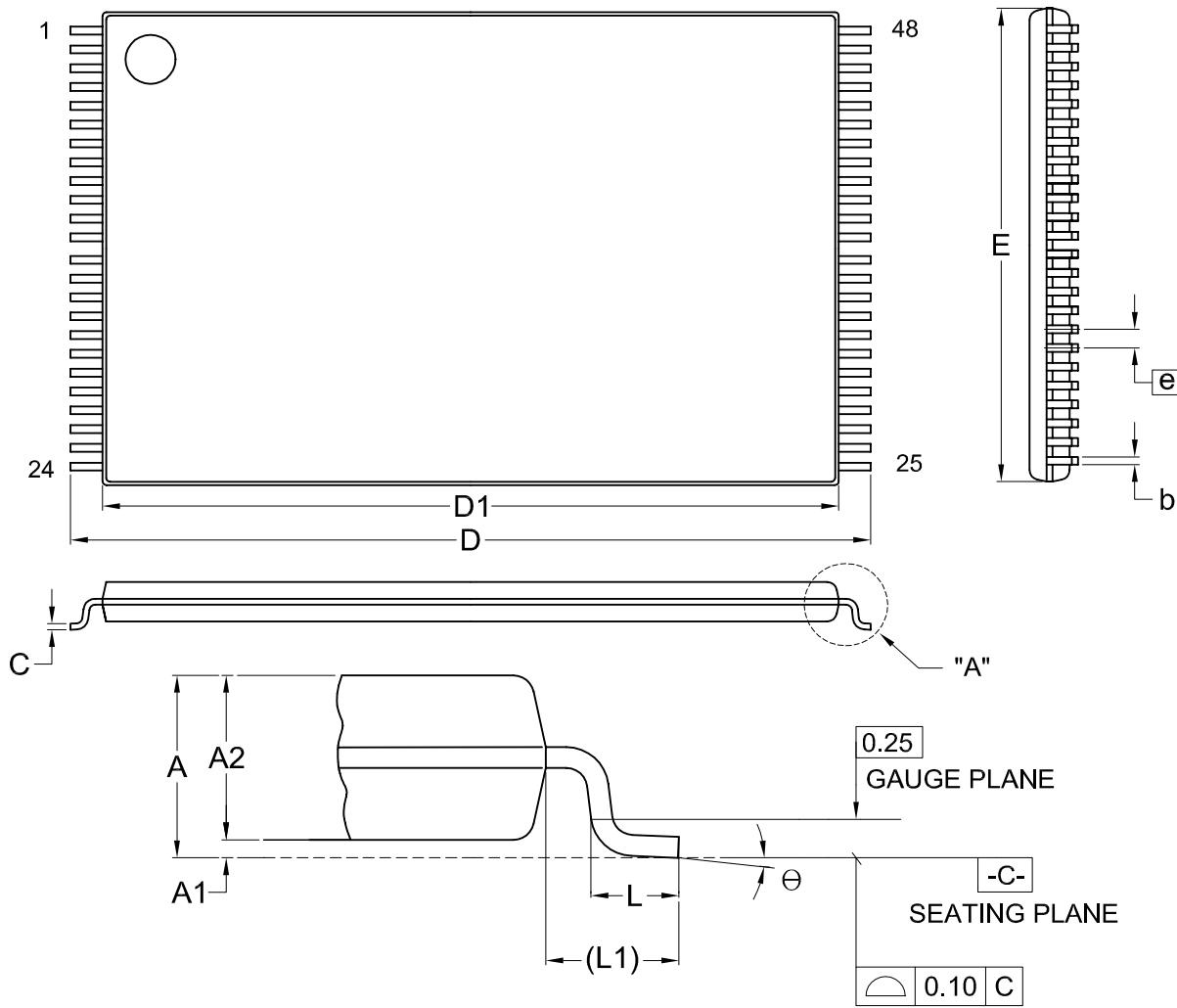

DETAIL "A"

Dimensions (inch dimensions are derived from the original mm dimensions)

SYMBOL		A	A1	A2	b	C	D	D1	E	e	L	L1	θ
UNIT													
mm	Min.	---	0.05	0.95	0.17	0.10	19.80	18.30	11.90		0.50	0.70	0
	Nom.	---	0.10	1.00	0.20	0.13	20.00	18.40	12.00	0.50	0.60	0.80	5
	Max.	1.20	0.15	1.05	0.27	0.21	20.20	18.50	12.10		0.70	0.90	8
Inch	Min.	---	0.002	0.037	0.007	0.004	0.780	0.720	0.469		0.020	0.028	0
	Nom.	---	0.004	0.039	0.008	0.005	0.787	0.724	0.472	0.020	0.024	0.031	5
	Max.	0.047	0.006	0.041	0.011	0.008	0.795	0.728	0.476		0.028	0.035	8

DWG.NO.	REVISION	REFERENCE			ISSUE DATE
		JEDEC	EIAJ		
6110-1607	7	MO-142			12-01-'03

Title: Package Outline for TSOP(I) 48L (12X20mm)REVERSE FORM

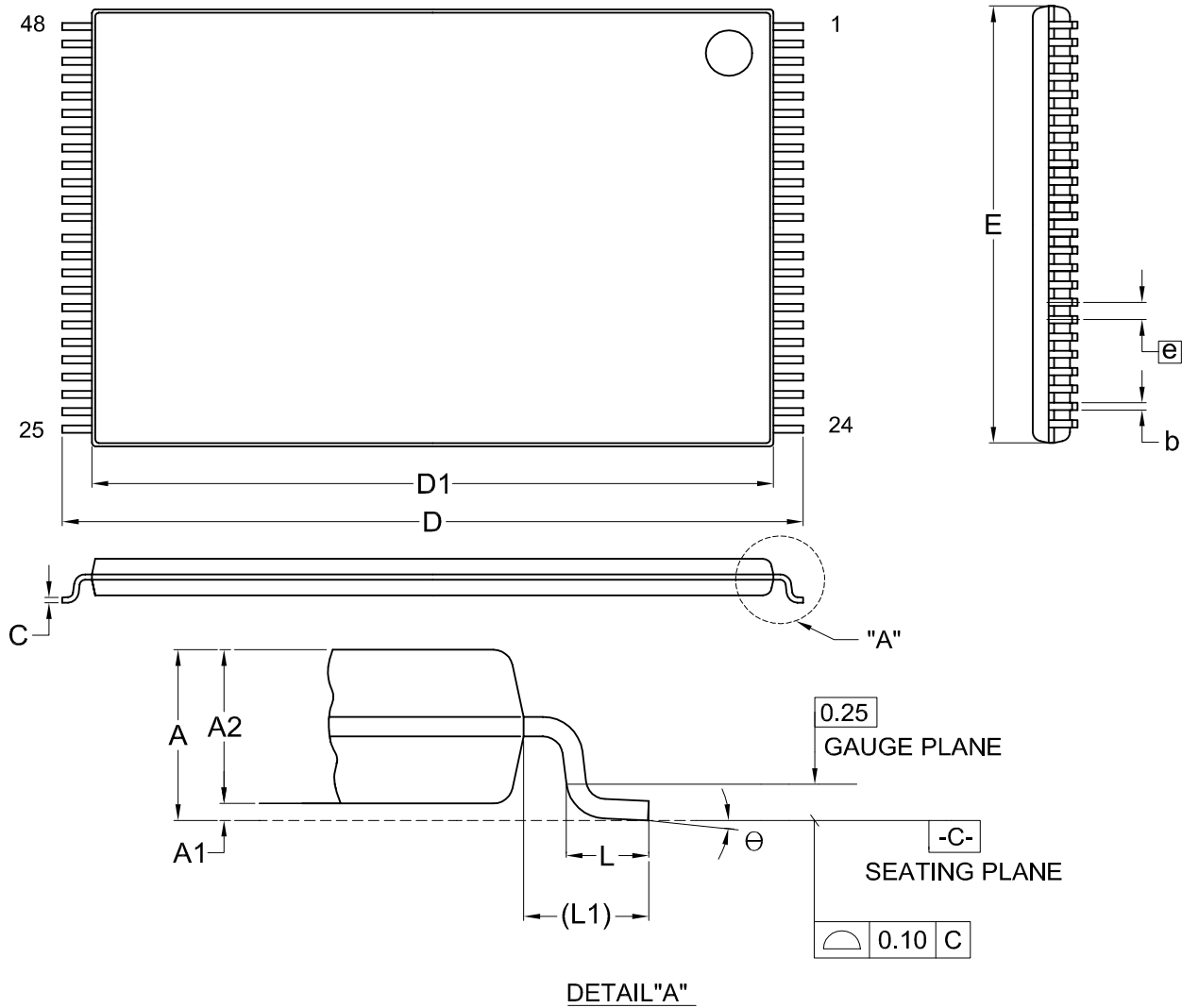

Dimensions (inch dimensions are derived from the original mm dimensions)

SYMBOL		A	A1	A2	b	C	D	D1	E	e	L	L1	Θ
UNIT													
mm	Min.	---	0.05	0.95	0.17	0.10	19.80	18.30	11.90		0.50	0.70	0
	Nom.	---	0.10	1.00	0.20	0.13	20.00	18.40	12.00	0.50	0.60	0.80	5
	Max.	1.20	0.15	1.05	0.27	0.21	20.20	18.50	12.10		0.70	0.90	8
Inch	Min.	---	0.002	0.037	0.007	0.004	0.780	0.720	0.469		0.020	0.028	0
	Nom.	---	0.004	0.039	0.008	0.005	0.787	0.724	0.472	0.020	0.024	0.031	5
	Max.	0.047	0.006	0.041	0.011	0.008	0.795	0.728	0.476		0.028	0.035	8

DWG.NO.	REVISION	REFERENCE			ISSUE DATE
		JEDEC	EIAJ		
6110-1607.1	7	MO-142			12-01-'03

Title: Package Outline for TSOP(II) 44L (400MIL)

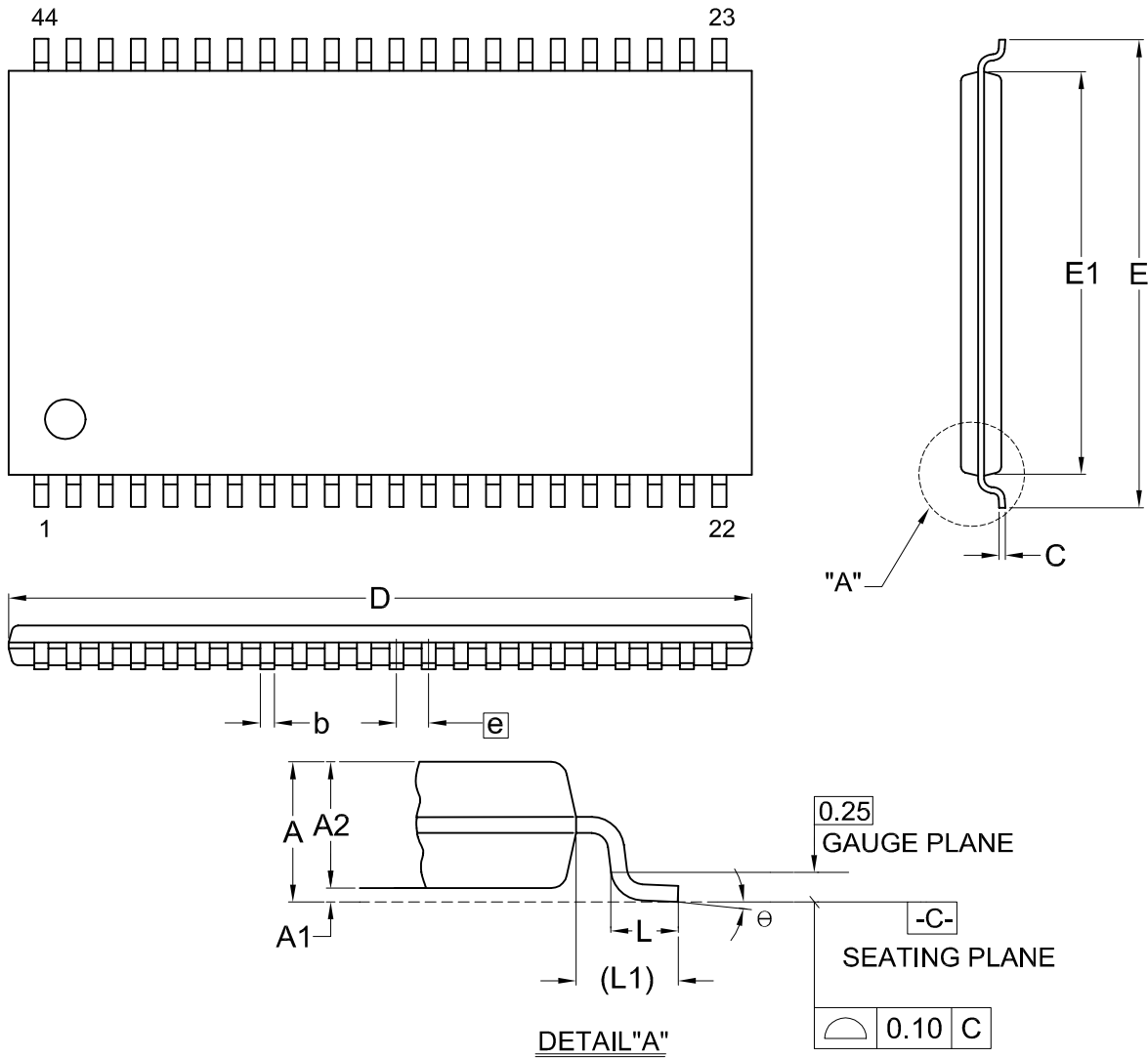

Dimensions (inch dimensions are derived from the original mm dimensions)

SYMBOL		A	A1	A2	b	C	D	E	E1	e	L	L1	Θ
UNIT													
mm	Min.	---	0.05	0.95	0.30	0.12	18.31	11.56	10.06		0.40	0.70	0
	Nom.	---	0.10	1.00	0.35	0.15	18.41	11.76	10.16	0.80	0.50	0.80	5
	Max.	1.20	0.15	1.05	0.45	0.21	18.51	11.96	10.26		0.60	0.90	8
Inch	Min.	---	0.002	0.037	0.012	0.005	0.721	0.455	0.396		0.016	0.028	0
	Nom.	---	0.004	0.039	0.014	0.006	0.725	0.463	0.400	0.031	0.020	0.031	5
	Max.	0.047	0.006	0.041	0.018	0.008	0.729	0.471	0.404		0.024	0.035	8

DWG.NO.	REVISION	REFERENCE			ISSUE DATE
		JEDEC	EIAJ		
6110-1701	6	MS-024			12-01-'03

REVISION HISTORY

REVISION	DESCRIPTION	PAGE	DATE
1.9	AC CHARACTERISTICS tOH 10ns-->0ns	P3	JAN/29/1999
2.0	DC CHARACTERISTICS ISTB2 5uA-->15uA	P3	SEP/03/1999
2.1	DC Characteristics voltage range VCC=2.9V~3.6V-->3.0V~3.6V	P3	DEC/24/1999
2.2	Modify Operating Current:60mA-->50mA	P1,3	DEC/29/2000
2.3	Modify Package Information	P5,6	JUL/18/2001
	Added 44-pin TSOP Package	P1,7	
	Added Access time:100ns	P1,3	
2.4	Change VCC from 3.0~3.6V to 2.7~3.3V	P1,3	AUG/03/2001
2.5	Change Voltage:2.7V~3.3V-->2.7V~3.6V	P1,3	AUG/21/2001
2.6	Change Voltage:2.7V~3.6V-->2.4V~3.6V	P1,3	NOV/26/2001
	Change Operating Current:50mA-->13mA	P1,3	
2.7	Change Voltage:2.4V~3.6V-->2.7V~3.6V	P1,3	NOV/29/2001
	Change Operating Current:13mA-->50mA	P1,3	
2.8	Removed 44-pin TSOP Package	P1,7	JAN/15/2002
2.9	1. Add supply voltage relative to VSS	P3	JUL/19/2002
	2. Change voltage on any pin relative to VSS:-0.5V to VCC+2.0	P3	
3.0	1. Modify Package Information	P5~7	NOV/21/2002
3.1	1. Add 44-pin TSOP package	P1,8	MAY/13/2003
3.2	1. Add access time:90ns	P1,3	JUL/09/2003
3.3	1. Delete MX23L6410RC/MC/YC-90	P1	SEP/08/2003
3.4	1. Modify random access: 90ns (max.) for 3.0V~3.6V; 100ns (max.) for 2.7V~3.6V	P1	SEP/26/2003
3.5	1. Add Notes: die form: 2.7~3.6V 90ns	P1	MAY/25/2004
3.6	1. Add I-grade package	P1	JUL/15/2004
3.7	1. Add I-grade temperature	P3,4	JUL/29/2004



MX23L6410

MACRONIX INTERNATIONAL CO., LTD.

Headquarters:

TEL:+886-3-578-6688

FAX:+886-3-563-2888

Europe Office :

TEL:+32-2-456-8020

FAX:+32-2-456-8021

Hong Kong Office :

TEL:+86-755-834-335-79

FAX:+86-755-834-380-78

Japan Office :

Kawasaki Office :

TEL:+81-44-246-9100

FAX:+81-44-246-9105

Osaka Office :

TEL:+81-6-4807-5460

FAX:+81-6-4807-5461

Singapore Office :

TEL:+65-6346-5505

FAX:+65-6348-8096

Taipei Office :

TEL:+886-2-2509-3300

FAX:+886-2-2509-2200

MACRONIX AMERICA, INC.

TEL:+1-408-262-8887

FAX:+1-408-262-8810

<http://www.macronix.com>
