

GaAs IC 4 Bit Digital Attenuator With Driver 1 dB LSB DC–2 GHz



AK002D4-24

Features

- Attenuation in 1 dB Steps to 15 dB
- Integral Driver ± 5 V Supply Voltages
- Low Cost SOIC-14 Plastic Package

Description

The AK002D4-24 is an IC FET digital attenuator consisting of four monolithic attenuators with an LSB of 1 dB and a total attenuation of 15 dB with all attenuators connected.

The device has integral drivers for each bit requiring less than 4 mA per bit. DC supply voltages of ± 5 V are required. The attenuator is packaged in a 14 lead plastic SOIC.

SOIC-14

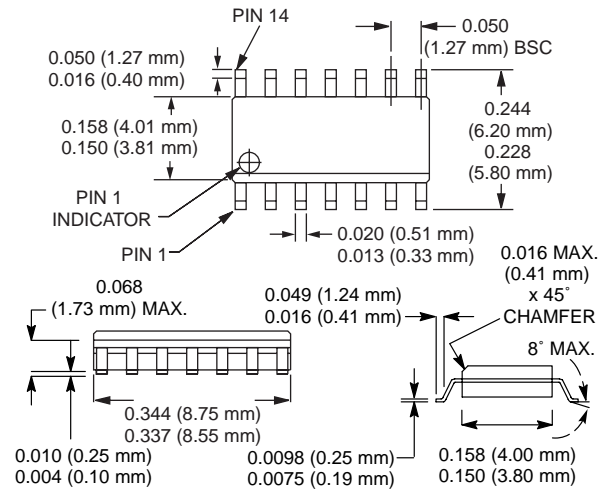

Electrical Specifications at 25°C (+5 V, -5 V)

Parameter ¹	Frequency ²	Min.	Typ.	Max.	Unit
Insertion Loss ³	DC–0.5 GHz		2.0	2.5	dB
	DC–1.0 GHz		2.5	3.0	dB
	DC–2.0 GHz		3.7	4.0	dB
Attenuation Accuracy Per Bit ⁴	DC–2.0 GHz	10% or ± 0.5 dB Whichever is Greater			dB
VSWR (I/O)	DC–0.5 GHz		1.3:1	1.5:1	
	DC–2.0 GHz		1.6:1	1.8:1	

Operating Characteristics at 25°C (+5 V, -5 V)

Parameter	Condition	Frequency	Min.	Typ.	Max.	Unit
Switching Characteristics ⁵	Rise, Fall (10/90% or 90/10% RF)			20		ns
	On, Off (50% CTL to 90/10% RF)			40		ns
	Video Feedthru			30		mV
Input Power for 1 dB Compression		0.50–2.0 GHz		+24		dBm
		0.05 GHz		+16		dBm
Intermodulation Intercept Point (IP3)	For Two-tone Input Power +13 dBm	0.50–2.0 GHz		+37		dBm
		0.05 GHz		+26		dBm
Control Voltages	V_{Low}		0.0		0.2	V
	V_{High}		4.5		5.0	V
Supply Voltages ^{6,7}	+5 V \pm 0.20 V @ 4 mA Typ.		4.8		5.2	V
	-5 V \pm 0.20 V @ 16 mA Typ.		-4.8		-5.2	V

1. All measurements made in a 50 Ω system, unless otherwise specified.
2. DC = 300 kHz.
3. Insertion loss changes by 0.003 dB/ $^{\circ}$ C.
4. Attenuation referenced to insertion loss.
5. Video feedthru measured with 1 ns risetime pulse and 500 MHz bandwidth.
6. Supply voltage and ground must be connected before control voltage is applied. Use of toggle switches or other similar components may produce voltage spikes which can cause irreversible damage to the device.
7. Current drain @ 85 $^{\circ}$ C = 6 mA Typ. @ +5 V, 20 mA Typ. @ -5 V.

Typical Performance Data (+5 V, -5 V)

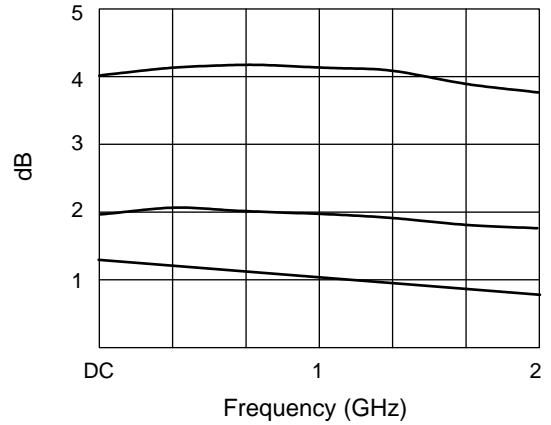
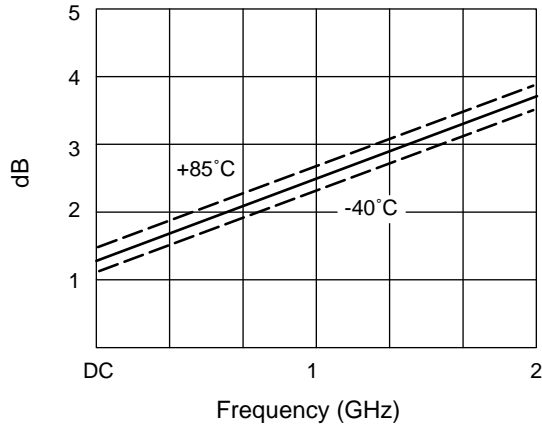

Insertion Loss vs. Frequency

1, 2, 4 dB Bits vs. Frequency

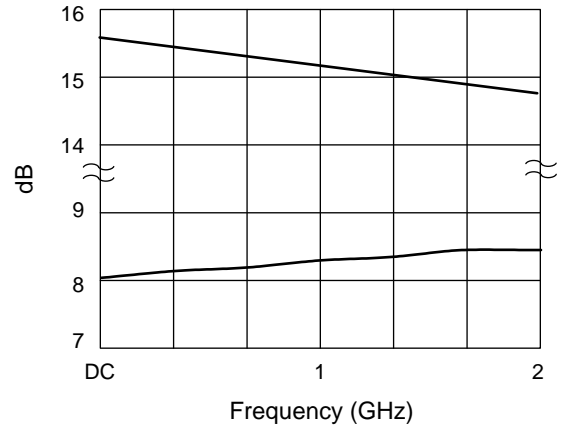
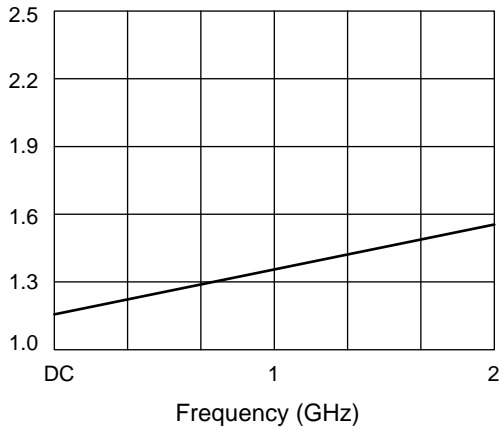

VSWR vs. Frequency (All States)

8, 15 dB Bits vs. Frequency

Absolute Maximum Ratings

Characteristic	Value
RF Input Power	0.5 W > 500 MHz 0.1 W @ 50 MHz
Supply Voltage	+6 V, -6 V
Control Voltage	+6 V
Operating Temperature	0°C to +70°C
Storage Temperature	-65°C to +150°C
θ_{JC}	30°C/W

Pin Out

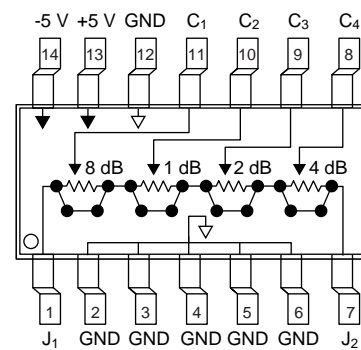

Truth Table

C ₁	C ₂	C ₃	C ₄	Attenuation J ₁ -J ₂
8 dB	1 dB	2 dB	4 dB	
0	0	0	1	Reference I.L.
0	1	0	1	1 dB
0	0	1	1	2 dB
0	0	0	0	4 dB
1	0	0	1	8 dB
1	1	1	0	15 dB

"0" = 0.0 to 0.2 V, "1" = 4.5 to 5.0 V.